



82370 INTEGRATED SYSTEM PERIPHERAL

- **High Performance 32-Bit DMA Controller for 16-Bit Bus**
 - 16 MBytes/Sec Maximum Data Transfer Rate at 16 MHz
 - 8 Independently Programmable Channels
- **20-Source Interrupt Controller**
 - Individually Programmable Interrupt Vectors
 - 15 External, 5 Internal Interrupts
 - 82C59A Superset
- **Four 16-Bit Programmable Interval Timers**
 - 82C54 Compatible
- **Software Compatible to 82380**
- **Programmable Wait State Generator**
 - 0 to 15 Wait States Pipelined
 - 1 to 16 Wait States Non-Pipelined
- **DRAM Refresh Controller**
- **80376 Shutdown Detect and Reset Control**
 - Software/Hardware Reset
- **High Speed CHMOS III Technology**
- **100-Pin Plastic Quad Flat-Pack Package and 132-Pin Pin Grid Array Package**
 - (See Packaging Handbook Order #240800-001, Package Type NG or Package Type A)
- **Optimized for Use with the 80376 Microprocessor**
 - Resides on Local Bus for Maximum Bus Bandwidth
 - 16 MHz Clock

The 82370 is a multi-function support peripheral that integrates system functions necessary in an 80376 environment. It has eight channels of high performance 32-bit DMA (32-bit internal, 16-bit external) with the most efficient transfer rates possible on the 80376 bus. System support peripherals integrated into the 82370 provide Interrupt Control, Timers, Wait State generation, DRAM Refresh Control, and System Reset logic.

The 82370's DMA Controller can transfer data between devices of different data path widths using a single channel. Each DMA channel operates independently in any of several modes. Each channel has a temporary data storage register for handling non-aligned data without the need for external alignment logic.

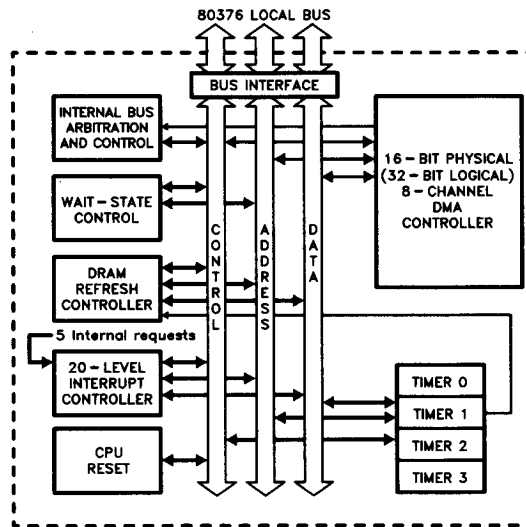

290164-1

Internal Block Diagram

Table of Contents

| CONTENTS | PAGE |
|--|-------|
| Pin Descriptions | 1-606 |
| 1.0 Functional Overview | 1-611 |
| 1.1 82370 Architecture | 1-611 |
| 1.1.1 DMA (Direct Memory Access) Controller | 1-613 |
| 1.1.2 Programmable Interval Timers | 1-614 |
| 1.1.3 Interrupt Controller | 1-615 |
| 1.1.4 Wait State Generator | 1-616 |
| 1.1.5 DRAM (Dynamic RAM) Refresh Controller | 1-616 |
| 1.1.6 CPU Reset Function | 1-616 |
| 1.1.7 Register Map Relocation | 1-617 |
| 1.2 Host Interface | 1-617 |
| 2.0 80376 Host Interface | 1-617 |
| 2.1 Master and Slave Modes | 1-618 |
| 2.2 80376 Interface Signals | 1-618 |
| 2.2.1 Clock (CLK2) | 1-619 |
| 2.2.2 Data Bus (D ₀ –D ₁₅) | 1-619 |
| 2.2.3 Address Bus (A ₂₃ –A ₁) | 1-619 |
| 2.2.4 Byte Enable (BHE#, BLE#) | 1-619 |
| 2.2.5 Bus Cycle Definition Signals (D/C#, W/R#, M/IO#) | 1-620 |
| 2.2.6 Address Status (ADS#) | 1-620 |
| 2.2.7 Transfer Acknowledge (READY#) | 1-620 |
| 2.2.8 Next Address Request (NA#) | 1-620 |
| 2.2.9 Reset (RESET, CPURST) | 1-621 |
| 2.2.10 Interrupt Out (INT) | 1-622 |
| 2.3 82370 Bus Timing | 1-622 |
| 2.3.1 Address Pipelining | 1-622 |
| 2.3.2 Master Mode Bus Timing | 1-622 |
| 2.3.3 Slave Mode Bus Timing | 1-623 |
| 3.0 DMA Controller | 1-625 |
| 3.1 Functional Description | 1-625 |
| 3.2 Interface Signals | 1-627 |
| 3.2.1 DREQn and EDACK (0–2) | 1-628 |
| 3.2.2 HOLD and HLDA | 1-628 |
| 3.2.3 EOP# | 1-629 |
| 3.3 Modes of Operation | 1-629 |
| 3.3.1 Target/Requester Definition | 1-629 |
| 3.3.2 Buffer Transfer Processes | 1-630 |

CONTENTS

PAGE

| | |
|---|-------|
| 3.0 DMA Controller (Continued) | |
| 3.3.3 Data Transfer Modes | 1-630 |
| 3.3.4 Channel Priority Arbitration | 1-634 |
| 3.3.5 Combining Priority Modes | 1-636 |
| 3.3.6 Bus Operation | 1-636 |
| 3.3.6.1 Fly-By Transfers | 1-636 |
| 3.3.6.2 Two-Cycle Transfers | 1-637 |
| 3.3.6.3 Data Path Width and Data Transfer Rate Considerations | 1-637 |
| 3.3.6.4 Read, Write, and Verify Cycles | 1-638 |
| 3.4 Bus Arbitration and Handshaking | 1-638 |
| 3.4.1 Synchronous and Asynchronous Sampling of DREQn and EOP# | 1-640 |
| 3.4.2 Arbitration of Cascaded Master Requests | 1-642 |
| 3.4.3 Arbitration of Refresh Requests | 1-643 |
| 3.5 DMA Controller Register Overview | 1-644 |
| 3.5.1 Control/Status Registers | 1-644 |
| 3.5.2 Channel Registers | 1-645 |
| 3.5.3 Temporary Registers | 1-646 |
| 3.6 DMA Controller Programming | 1-646 |
| 3.6.1 Buffer Processes | 1-647 |
| 3.6.1.1 Single Buffer Process | 1-647 |
| 3.6.1.2 Buffer Auto-Initialize Process | 1-647 |
| 3.6.1.3 Buffer Chaining Process | 1-648 |
| 3.6.2 Data Transfer Modes | 1-648 |
| 3.6.3 Cascaded Bus Masters | 1-648 |
| 3.6.4 Software Commands | 1-648 |
| 3.7 Register Definitions | 1-648 |
| 3.8 8237A Compatibility | 1-655 |
| 4.0 Programmable Interrupt Controller (PIC) | 1-655 |
| 4.1 Functional Description | 1-655 |
| 4.1.1 Internal Block Diagram | 1-655 |
| 4.1.2 Interrupt Controller Banks | 1-656 |
| 4.2 Interface Signals | 1-658 |
| 4.2.1 Interrupt Inputs | 1-658 |
| 4.2.2 Interrupt Output (INT) | 1-658 |
| 4.3 Bus Functional Description | 1-658 |
| 4.4 Modes of Operation | 1-659 |
| 4.4.1 End-of-Interrupt | 1-660 |
| 4.4.2 Interrupt Priorities | 1-660 |
| 4.4.2.1 Fully Nested Mode | 1-660 |
| 4.4.2.2 Automatic Rotation—Equal Priority Devices | 1-661 |
| 4.4.2.3 Specific Rotation—Specific Priority | 1-662 |
| 4.4.2.4 Interrupt Priority Mode Summary | 1-662 |

CONTENTS

PAGE

4.0 Programmable Interrupt Controller (Continued)

- 4.4.3 Interrupt Masking 1-662
- 4.4.4 Edge or Level Interrupt Triggering 1-663
- 4.4.5 Interrupt Cascading 1-663
 - 4.4.5.1 Special Fully Nested Mode 1-664
- 4.4.6 Reading Interrupt Status 1-664
 - 4.4.6.1 Poll Command 1-664
 - 4.4.6.2 Reading Interrupt Registers 1-664
- 4.5 Register Set Overview 1-664
 - 4.5.1 Initialization Command Words (ICW) 1-666
 - 4.5.2 Operation Control Words (OCW) 1-666
 - 4.5.3 Poll/Interrupt Request/In-Service Status Register 1-667
 - 4.5.4 Interrupt Mask Register (IMR) 1-667
 - 4.5.5 Vector Register (VR) 1-667
- 4.6 Programming 1-667
 - 4.6.1 Initialization (ICW) 1-667
 - 4.6.2 Vector Registers (VR) 1-668
 - 4.6.3 Operation Control Words (OCW) 1-669
 - 4.6.3.1 Read Status and Poll Commands (OCW3) 1-669
- 4.7 Register Bit Definition 1-669
- 4.8 Register Operational Summary 1-673

5.0 Programmable Interval Timer 1-673

- 5.1 Functional Description 1-673
 - 5.1.1 Internal Architecture 1-674
- 5.2 Interface Signals 1-676
 - 5.2.1 CLKIN 1-676
 - 5.2.2 TOUT1, TOUT2#, TOUT3# 1-676
 - 5.2.3 GATE 1-676
- 5.3 Modes of Operation 1-676
 - 5.3.1 Mode 0—Interrupt on Terminal Count 1-676
 - 5.3.2 Mode 1—GATE Retriggerable One-Shot 1-677
 - 5.3.3 Mode 2—Rate Generator 1-678
 - 5.3.4 Mode 3—Square Wave Generator 1-679
 - 5.3.5 Mode 4—Initial Count Triggered Strobe 1-681
 - 5.3.6 Mode 5—GATE Retriggerable Strobe 1-682
 - 5.3.7 Operation Common to All Modes 1-683
 - 5.3.7.1 GATE 1-683
 - 5.3.7.2 Counter 1-684
- 5.4 Register Set Overview 1-684
 - 5.4.1 Counter 0, 1, 2, 3 Registers 1-684
 - 5.4.2 Control Word Register I & II 1-684

1



CONTENTS

PAGE

| | |
|--|-------|
| 5.0 Programmable Interval Timer (Continued) | |
| 5.5 Programming | 1-685 |
| 5.5.1 Initialization | 1-685 |
| 5.5.2 Read Operation | 1-685 |
| 5.6 Register Bit Definitions | 1-687 |
| 6.0 Wait State Generator | 1-689 |
| 6.1 Functional Description | 1-689 |
| 6.2 Interface Signals | 1-689 |
| 6.2.1 READY# | 1-689 |
| 6.2.2 READYO# | 1-689 |
| 6.2.3 WSC (0–1) | 1-689 |
| 6.3 Bus Function | 1-690 |
| 6.3.1 Wait States in Non-Pipelined Cycle | 1-690 |
| 6.3.2 Wait States in Pipelined Cycles | 1-691 |
| 6.3.3 Extending and Early Terminating Bus Cycle | 1-691 |
| 6.4 Register Set Overview | 1-693 |
| 6.5 Programming | 1-693 |
| 6.6 Register Bit Definition | 1-693 |
| 6.7 Application Issues | 1-694 |
| 6.7.1 External 'READY' Control Logic | 1-694 |
| 7.0 DRAM Refresh Controller | 1-695 |
| 7.1 Functional Description | 1-695 |
| 7.2 Interface Signals | 1-695 |
| 7.2.1 TOUT1/REF# | 1-695 |
| 7.3 Bus Function | 1-695 |
| 7.3.1 Arbitration | 1-695 |
| 7.4 Modes of Operation | 1-696 |
| 7.4.1 Word Size and Refresh Address Counter | 1-696 |
| 7.5 Register Set Overview | 1-696 |
| 7.6 Programming | 1-697 |
| 7.7 Register Bit Definition | 1-697 |
| 8.0 Relocation Register, Address Decode and Chip-Select (CHPSEL#) | 1-697 |
| 8.1 Relocation Register | 1-697 |
| 8.1.1 I/O-Mapped 82370 | 1-698 |
| 8.1.2 Memory-Mapped 82370 | 1-698 |
| 8.2 Address Decoding | 1-698 |
| 8.3 Chip-Select (CHPSEL#) | 1-698 |

CONTENTS

| | PAGE |
|---|-------|
| 9.0 CPU Reset and Shutdown Detect | 1-699 |
| 9.1 Hardware Reset | 1-699 |
| 9.2 Software Reset | 1-699 |
| 9.3 Shutdown Detect | 1-699 |
| 10.0 Internal Control and Diagnostic Ports | 1-700 |
| 10.1 Internal Control Port | 1-700 |
| 10.2 Diagnostic Ports | 1-700 |
| 11.0 Internal Reserved I/O Ports | 1-700 |
| 12.0 Package Thermal Specifications | 1-701 |
| 13.0 Electrical Specifications | 1-702 |
| Appendix A—Ports Listed by Address | 1-710 |
| Appendix B—Ports Listed by Function | 1-714 |
| Appendix C—System Notes | 1-718 |

Pin Descriptions

The 82370 provides all of the signals necessary to interface an 80376 host processor. It has a separate 24-bit address and 16-bit data bus. It also has a set of control signals to support operation as a bus master or a bus slave. Several special function signals

exist on the 82370 for interfacing the system support peripherals to their respective system counterparts. Following are the definitions of the individual pins of the 82370. These brief descriptions are provided as a reference. Each signal is further defined within the sections which describe the associated 82370 function.

| Symbol | Type | Name and Function |
|---------------------------------|------|--|
| A ₁ –A ₂₃ | I/O | ADDRESS BUS: Outputs physical memory or port I/O addresses. See Address Bus (2.2.3) for additional information. |
| BHE # BLE # | I/O | BYTE ENABLES: Indicate which data bytes of the data bus take part in a bus cycle. See Byte Enable (2.2.4) for additional information. |
| D ₀ –D ₁₅ | I/O | DATA BUS: This is the 16-bit data bus. These pins are active outputs during interrupt acknowledges, during Slave accesses, and when the 82370 is in the Master Mode. |
| CLK2 | I | PROCESSOR CLOCK: This pin must be connected to the processor's clock, CLK2. The 82370 monitors the phase of this clock in order to remain synchronized with the CPU. This clock drives all of the internal synchronous circuitry. |
| D/C # | I/O | DATA/CONTROL: D/C # is used to distinguish between CPU control cycles and DMA or CPU data access cycles. It is active as an output only in the Master Mode. |
| W/R # | I/O | WRITE/READ: W/R # is used to distinguish between write and read cycles. It is active as an output only in the Master Mode. |
| M/IO # | I/O | MEMORY/IO: M/IO # is used to distinguish between memory and IO accesses. It is active as an output only in the Master Mode. |
| ADS # | I/O | ADDRESS STATUS: This signal indicates presence of a valid address on the address bus. It is active as output only in the Master Mode. ADS # is active during the first T-state where addresses and control signals are valid. |
| NA # | I | NEXT ADDRESS: Asserted by a peripheral or memory to begin a pipelined address cycle. This pin is monitored only while the 82370 is in the Master Mode. In the Slave Mode, pipelining is determined by the current and past status of the ADS # and READY # signals. |
| HOLD | O | HOLD REQUEST: This is an active-high signal to the Bus Master to request control of the system bus. When control is granted, the Bus Master activates the hold acknowledge signal (HLDA). |
| HLDA | I | HOLD ACKNOWLEDGE: This input signal tells the DMA controller that the Bus Master has relinquished control of the system bus to the DMA controller. |

Pin Descriptions (Continued)

| Symbol | Type | Name and Function |
|-----------------|------|--|
| DREQ (0-3, 5-7) | I | DMA REQUEST: The DMA Request inputs monitor requests from peripherals requiring DMA service. Each of the eight DMA channels has one DREQ input. These active-high inputs are internally synchronized and prioritized. Upon request, channel 0 has the highest priority and channel 7 the lowest. |
| DREQ4/IRQ9# | I | DMA/INTERRUPT REQUEST: This is the DMA request input for channel 4. It is also connected to the interrupt controller via interrupt request 9. This internal connection is available for DMA channel 4 only. The interrupt input is active low and can be programmed as either edge or level triggered. Either function can be masked by the appropriate mask register. Priorities of the DMA channel and the interrupt request are not related but follow the rules of the individual controllers. Note that this pin has a weak internal pull-up. This causes the interrupt request to be inactive, but the DMA request will be active if there is no external connection made. Most applications will require that either one or the other of these functions be used, but not both. For this reason, it is advised that DMA channel 4 be used for transfers where a software request is more appropriate (such as memory-to-memory transfers). In such an application, DREQ4 can be masked by software, freeing IRQ9# for other purposes. |
| EOP# | I/O | END OF PROCESS: As an output, this signal indicates that the current Requester access is the last access of the currently operating DMA channel. It is activated when Terminal Count is reached. As an input, it signals the DMA channel to terminate the current buffer and proceed to the next buffer, if one is available. This signal may be programmed as an asynchronous or synchronous input. EOP# must be connected to a pull-up resistor. This will prevent erroneous external requests for termination of a DMA process. |
| EDACK (0-2) | O | ENCODED DMA ACKNOWLEDGE: These signals contain the encoded acknowledgment of a request for DMA service by a peripheral. The binary code formed by the three signals indicates which channel is active. Channel 4 does not have a DMA acknowledge. The inactive state is indicated by the code 100. During a Requester access, EDACK presents the code for the active DMA channel. During a Target access, EDACK presents the inactive code 100. |
| IRQ (11-23)# | I | INTERRUPT REQUEST: These are active low interrupt request inputs. The inputs can be programmed to be edge or level sensitive. Interrupt priorities are programmable as either fixed or rotating. These inputs have weak internal pull-up resistors. Unused interrupt request inputs should be tied inactive externally. |
| INT | O | INTERRUPT OUT: INT signals that an interrupt request is pending. |
| CLKIN | I | TIMER CLOCK INPUT: This is the clock input signal to all of the 82370's programmable timers. It is independent of the system clock input (CLK2). |
| TOUT1/REF# | O | TIMER 1 OUTPUT/REFRESH: This pin is software programmable as either the direct output of Timer 1, or as the indicator of a refresh cycle in progress. As REF#, this signal is active during the memory read cycle which occurs during refresh. |

1

Pin Descriptions (Continued)

| Symbol | Type | Name and Function |
|-----------------|------|---|
| TOUT2# /IRQ3# | I/O | TIMER 2 OUTPUT/INTERRUPT REQUEST: This is the inverted output of Timer 2. It is also connected directly to interrupt request 3. External hardware can use IRQ3# if Timer 2 is programmed as OUT = 0 (TOUT2# = 1). |
| TOUT3# | O | TIMER 3 OUTPUT: This is the inverted output of Timer 3. |
| READY# | I | READY INPUT: This active-low input indicates to the 82370 that the current bus cycle is complete. READY is sampled by the 82370 both while it is in the Master Mode, and while it is in the Slave Mode. |
| WSC (0-1) | I | WAIT STATE CONTROL: WSC0 and WSC1 are inputs used by the Wait-State Generator to determine the number of wait states required by the currently accessed memory or I/O. The binary code on these pins, combined with the M/IO# signal, selects an internal register in which a wait-state count is stored. The combination WSC = 11 disables the wait-state generator. |
| READYO# | O | READY OUTPUT: This is the synchronized output of the wait-state generator. It is also valid during CPU accesses to the 82370 in the Slave Mode when the 82370 requires wait states. READYO# should feed directly the processor's READY# input. |
| RESET | I | RESET: This synchronous input serves to initialize the state of the 82370 and provides basis for the CPURST output. RESET must be held active for at least 15 CLK2 cycles in order to guarantee the state of the 82370. After Reset, the 82370 is in the Slave Mode with all outputs except timers and interrupts in their inactive states. The state of the timers and interrupt controller must be initialized through software. This input must be active for the entire time required by the host processor to guarantee proper reset. |
| CHPSEL# | O | CHIP SELECT: This pin is driven active whenever the 82370 is addressed in a slave bus read or write cycle. It is also active during interrupt acknowledge cycles when the 82370 is driving the Data Bus. It can be used to control the local bus transceivers to prevent contention with the system bus. |
| CPURST | O | CPU RESET: CPURST provides a synchronized reset signal for the CPU. It is activated in the event of a software reset command, a processor shut-down detect, or a hardware reset via the RESET pin. The 82370 holds CPURST active for 62 clocks in response to either a software reset command or a shut-down detection. Otherwise CPURST reflects the RESET input. |
| V _{CC} | | POWER: + 5V input power. |
| V _{SS} | | Ground Reference. |

Table 1. Wait-State Select Inputs

| Port Address | Wait-State Registers | | | | Select Inputs | |
|--------------|----------------------|----|-------|----|---------------|------|
| | D7 | D4 | D3 | D0 | WSC1 | WSC0 |
| 72H | MEMORY 0 | | I/O 0 | | 0 | 0 |
| 73H | MEMORY 1 | | I/O 1 | | 0 | 1 |
| 74H | MEMORY 2 | | I/O 2 | | 1 | 0 |
| | DISABLED | | | | 1 | 1 |
| M/IO# | 1 | | 0 | | | |

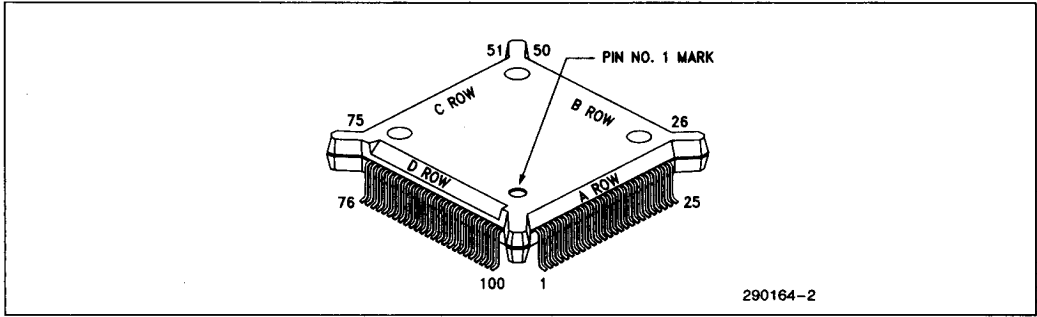

100 Pin Quad Flat-Pack Pin Out (Top View)

1

| A Row | | B Row | | C Row | | D Row | |
|-------|-----------------|-------|-----------------|-------|-----------------|-------|-----------------|
| Pin | Label | Pin | Label | Pin | Label | Pin | Label |
| 1 | CPURST | 26 | V _{CC} | 51 | A ₁₁ | 76 | DREQ5 |
| 2 | INT | 27 | D ₁₁ | 52 | A ₁₀ | 77 | DREQ4/IRQ9# |
| 3 | V _{CC} | 28 | D ₄ | 53 | A ₉ | 78 | DREQ3 |
| 4 | V _{SS} | 29 | D ₁₂ | 54 | A ₈ | 79 | DREQ2 |
| 5 | TOUT2#/IRQ3# | 30 | D ₅ | 55 | A ₇ | 80 | DREQ1 |
| 6 | TOUT3# | 31 | D ₁₃ | 56 | A ₆ | 81 | DREQ0 |
| 7 | D/C# | 32 | D ₆ | 57 | A ₅ | 82 | IRQ23# |
| 8 | V _{CC} | 33 | V _{SS} | 58 | V _{CC} | 83 | IRQ22# |
| 9 | W/R# | 34 | D ₁₄ | 59 | A ₄ | 84 | IRQ21# |
| 10 | M/IO# | 35 | D ₇ | 60 | A ₃ | 85 | IRQ20# |
| 11 | HOLD | 36 | D ₁₅ | 61 | A ₂ | 86 | IRQ19# |
| 12 | TOUT1/REF# | 37 | A ₂₃ | 62 | A ₁ | 87 | IRQ18# |
| 13 | CLK2 | 38 | A ₂₂ | 63 | V _{SS} | 88 | IRQ17# |
| 14 | V _{SS} | 39 | A ₂₁ | 64 | BLE# | 89 | IRQ16# |
| 15 | READYO# | 40 | A ₂₀ | 65 | BHE# | 90 | IRQ15# |
| 16 | EOP# | 41 | A ₁₉ | 66 | V _{SS} | 91 | IRQ14# |
| 17 | CHPSEL# | 42 | A ₁₈ | 67 | ADS# | 92 | IRQ13# |
| 18 | V _{CC} | 43 | V _{CC} | 68 | V _{CC} | 93 | IRQ12# |
| 19 | D ₀ | 44 | A ₁₇ | 69 | EDACK2 | 94 | IRQ11# |
| 20 | D ₈ | 45 | A ₁₆ | 70 | EDACK1 | 95 | CLKIN |
| 21 | D ₁ | 46 | A ₁₅ | 71 | EDACK0 | 96 | WSC0 |
| 22 | D ₉ | 47 | A ₁₄ | 72 | HLDA | 97 | WSC1 |
| 23 | D ₂ | 48 | V _{SS} | 73 | DREQ7 | 98 | RESET |
| 24 | D ₁₀ | 49 | A ₁₃ | 74 | DREQ6 | 99 | READY# |
| 25 | D ₃ | 50 | A ₁₂ | 75 | NA# | 100 | V _{SS} |

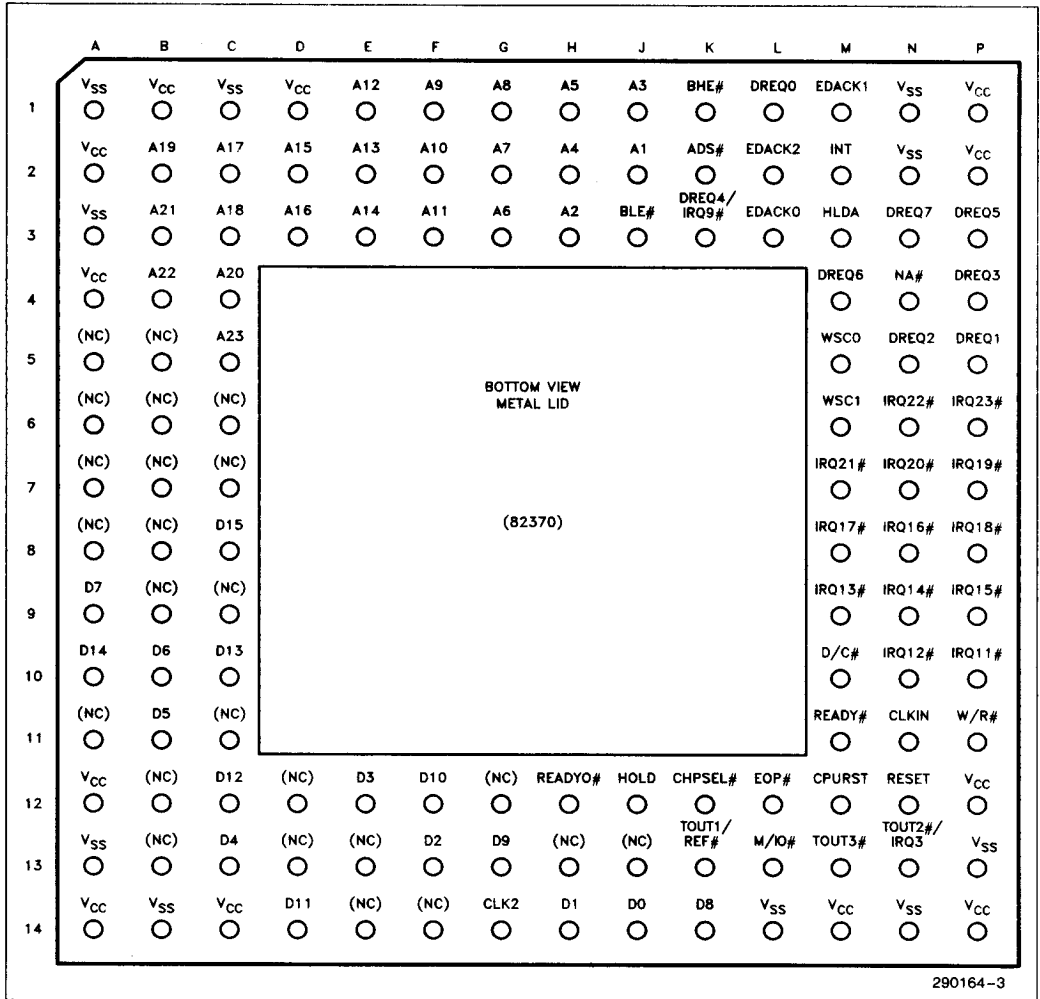

290164-3

82370 PGA Pinout

| Pin | Label | Pin | Label | Pin | Label | Pin | Label |
|-----|-----------------|-----|-----------------|-----|-----------------|-----|-----------------|
| G14 | CLK2 | D14 | D ₁₁ | L1 | DREQ0 | A2 | V _{CC} |
| N12 | RESET | F12 | D ₁₀ | P6 | IRQ23# | P2 | V _{CC} |
| M12 | CPURST | G13 | D ₉ | N6 | IRQ22# | A4 | V _{CC} |
| C5 | A ₂₃ | K14 | D ₈ | M7 | IRQ21# | A12 | V _{CC} |
| B4 | A ₂₂ | A9 | D ₇ | N7 | IRQ20# | P12 | V _{CC} |
| B3 | A ₂₁ | B10 | D ₆ | P7 | IRQ19# | A14 | V _{CC} |
| C4 | A ₂₀ | B11 | D ₅ | P8 | IRQ18# | C14 | V _{CC} |
| B2 | A ₁₉ | C13 | D ₄ | M8 | IRQ17# | M14 | V _{CC} |
| C3 | A ₁₈ | E12 | D ₃ | N8 | IRQ16# | P14 | V _{CC} |
| C2 | A ₁₇ | F13 | D ₂ | P9 | IRQ15# | A5 | NC |
| D3 | A ₁₆ | H14 | D ₁ | N9 | IRQ14# | B5 | NC |
| D2 | A ₁₅ | J14 | D ₀ | M9 | IRQ13# | A6 | NC |
| E3 | A ₁₄ | P11 | W/R# | N10 | IRQ12# | B6 | NC |
| E2 | A ₁₃ | L13 | M/IO# | P10 | IRQ11# | C6 | NC |
| E1 | A ₁₂ | K2 | ADS# | M5 | WSC0 | A7 | NC |
| F3 | A ₁₁ | M10 | D/C# | M6 | WSC1 | B7 | NC |
| F2 | A ₁₀ | N4 | NA# | M13 | TOUT3# | C7 | NC |
| F1 | A ₉ | M11 | READY# | N13 | TOUT2#/IRQ3# | A8 | NC |
| G1 | A ₈ | H12 | READYO# | K13 | TOUT1/REF# | B8 | NC |
| G2 | A ₇ | J12 | HOLD | N11 | CLKIN | B9 | NC |
| G3 | A ₆ | M3 | HLDA | A1 | V _{SS} | C9 | NC |
| H1 | A ₅ | M2 | INT | C1 | V _{SS} | A11 | NC |
| H2 | A ₄ | L12 | EOP# | N1 | V _{SS} | B12 | NC |
| J1 | A ₃ | L2 | EDACK2 | N2 | V _{SS} | C11 | NC |
| H3 | A ₂ | M1 | EDACK1 | A3 | V _{SS} | D12 | NC |
| J2 | A ₁ | L3 | EDACK0 | A13 | V _{SS} | G12 | NC |
| J3 | BLE# | N3 | DREQ7 | P13 | V _{SS} | B13 | NC |
| K1 | BHE# | M4 | DREQ6 | B14 | V _{SS} | D13 | NC |
| K12 | CHPSEL# | P3 | DREQ5 | L14 | V _{SS} | E13 | NC |
| C8 | D ₁₅ | K3 | DREQ4/IRQ9# | N14 | V _{SS} | H13 | NC |
| A10 | D ₁₄ | P4 | DREQ3 | B1 | V _{CC} | J13 | NC |
| C10 | D ₁₃ | N5 | DREQ2 | D1 | V _{CC} | E14 | NC |
| C12 | D ₁₂ | P5 | DREQ1 | P1 | V _{CC} | F14 | NC |

1

1.0 FUNCTIONAL OVERVIEW

The 82370 contains several independent functional modules. The following is a brief discussion of the components and features of the 82370. Each module has a corresponding detailed section later in this data sheet. Those sections should be referred to for design and programming information.

1.1 82370 Architecture

The 82370 is comprised of several computer system functions that are normally found in separate LSI and VLSI components. These include: a high-performance, eight-channel, 32-bit Direct Memory Access Controller; a 20-level Programmable Interrupt

Controller which is a superset of the 82C59A; four 16-bit Programmable Interval Timers which are functionally equivalent to the 82C54 timers; a DRAM Refresh Controller; a Programmable Wait State Generator; and system reset logic. The interface to the 82370 is optimized for high-performance operation with the 80376 microprocessor.

The 82370 operates directly on the 80376 bus. In the Slave Mode, it monitors the state of the processor at all times and acts or idles according to the commands of the host. It monitors the address pipeline status and generates the programmed number of wait states for the device being accessed. The 82370 also has logic to the reset of the 80376 via hardware or software reset requests and processor shutdown status.

After a system reset, the 82370 is in the Slave Mode. It appears to the system as an I/O device. It becomes a bus master when it is performing DMA transfers.

are automatically inserted into the access cycle. This allows the programmer to write initialization routines, etc. without regard to hardware recovery times.

To maintain compatibility with existing software, the registers within the 82370 are accessed as bytes. If the internal logic of the 82370 requires a delay before another access by the processor, wait states

Figure 1-1 shows the basic architectural components of the 82370. The following sections briefly discuss the architecture and function of each of the distinct sections of the 82370.

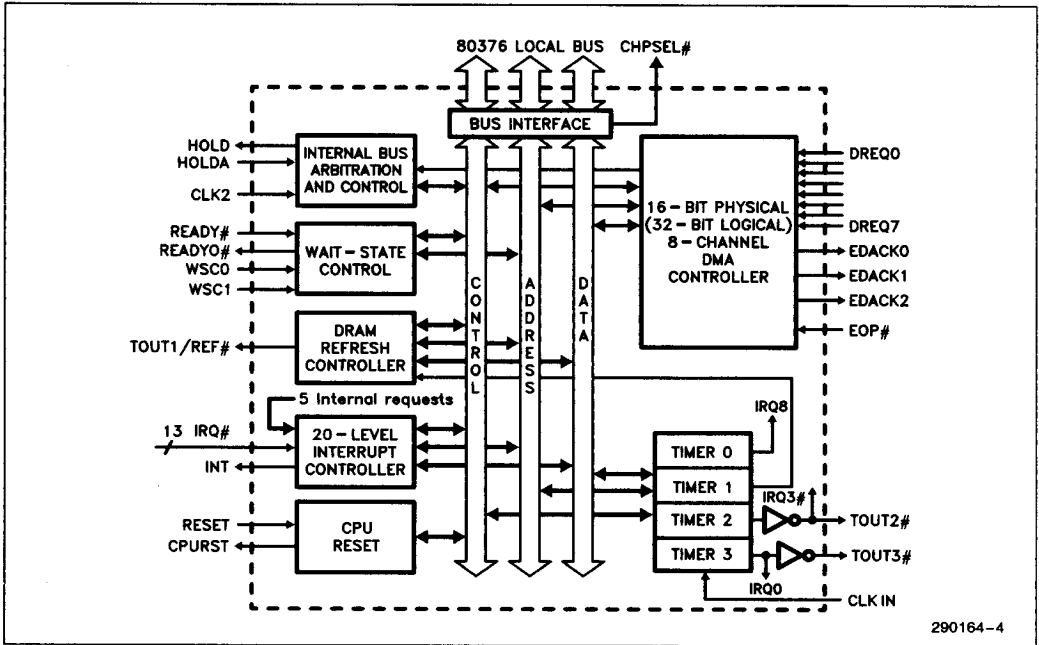

Figure 1-1. Architecture of the 82370

1.1.1 DMA CONTROLLER

The 82370 contains a high-performance, 8-channel DMA Controller. It provides a 32-bit internal data path. Through its 16-bit external physical data bus, it is capable of transferring data in any combination of bytes, words and double-words. The addresses of both source and destination can be independently incremented, decremented or held constant, and cover the entire 16-bit physical address space of the 80376. It can disassemble and assemble non-aligned data via a 32-bit internal temporary data storage register. Data transferred between devices of different data path widths can also be assembled and disassembled using the internal temporary data storage register. The DMA Controller can also transfer aligned data between I/O and memory on the fly, allowing data transfer rates up to 16 megabytes per second for an 82370 operating at 16 MHz. Figure 1-2 illustrates the functional components of the DMA Controller.

There are twenty-four general status and command registers in the 82370 DMA Controller. Through these registers any of the channels may be programmed into any of the possible modes. The operating modes of any one channel are independent of the operation of the other channels.

Each channel has three programmable registers which determine the location and amount of data to be transferred:

- Byte Count Register—Number of bytes to transfer. (24-bits)
- Requester Register — Byte Address of memory or peripheral which is requesting DMA service. (24-bits)
- Target Register — Byte Address of peripheral or memory which will be accessed. (24-bits)

There are also port addresses which, when accessed, cause the 82370 to perform specific functions. The actual data written doesn't matter, the act of writing to the specific address causes the command to be executed. The commands which operate in this mode are: Master Clear, Clear Terminal Count Interrupt Request, Clear Mask Register, and Clear Byte Pointer Flip-Flop.

DMA transfers can be done between all combinations of memory and I/O; memory-to-memory, memory-to-I/O, I/O-to-memory, and I/O-to-I/O. DMA service can be requested through software and/or hardware. Hardware DMA acknowledge signals are available for all channels (except channel 4) through an encoded 3-bit DMA acknowledge bus (EDACK0-2).

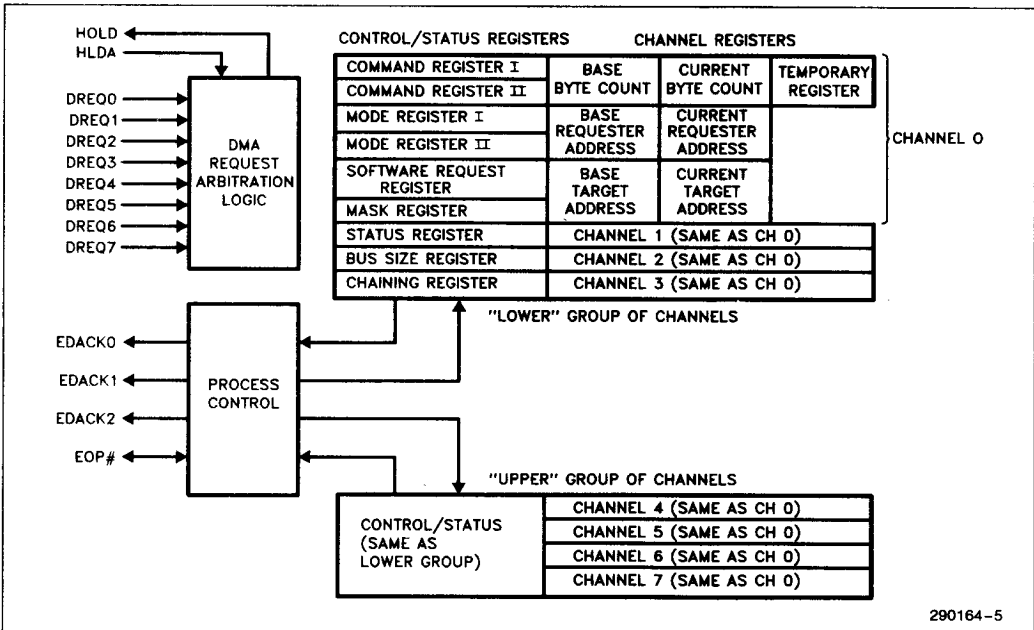

Figure 1-2. 82370 DMA Controller

290164-5



The 82370 DMA Controller transfers blocks of data (buffers) in three modes: Single Buffer, Buffer Auto-Initialize, and Buffer Chaining. In the Single Buffer Process, the 82370 DMA Controller is programmed to transfer one particular block of data. Successive transfers then require reprogramming of the DMA channel. Single Buffer transfers are useful in systems where it is known at the time the transfer begins what quantity of data is to be transferred, and there is a contiguous block of data area available.

The Buffer Auto-Initialize Process allows the same data area to be used for successive DMA transfers without having to reprogram the channel.

The Buffer Chaining Process allows a program to specify a list of buffer transfers to be executed. The 82370 DMA Controller, through interrupt routines, is reprogrammed from the list. The channel is reprogrammed for a new buffer before the current buffer transfer is complete. This pipelining of the channel programming process allows the system to allocate non-contiguous blocks of data storage space, and transfer all of the data with one DMA process. The buffers that make up the chain do not have to be in contiguous locations.

Channel priority can be fixed or rotating. Fixed priority allows the programmer to define the priority of DMA channels based on hardware or other fixed pa-

rameters. Rotating priority is used to provide peripherals access to the bus on a shared basis.

With fixed priority, the programmer can set any channel to have the current lowest priority. This allows the user to reset or manually rotate the priority schedule without reprogramming the command registers.

1.1.2 PROGRAMMABLE INTERVAL TIMERS

Four 16-bit programmable interval timers reside within the 82370. These timers are identical in function to the timers in the 82C54 Programmable Interval Timer. All four of the timers share a common clock input which can be independent of the system clock. The timers are capable of operating in six different modes. In all of the modes, the current count can be latched and read by the 80376 at any time, making these very versatile event timers. Figure 1-3 shows the functional components of the Programmable Interval Timers.

The outputs of the timers are directed to key system functions, making system design simpler. Timer 0 is routed directly to an interrupt input and is not available externally. This timer would typically be used to generate time-keeping interrupts.

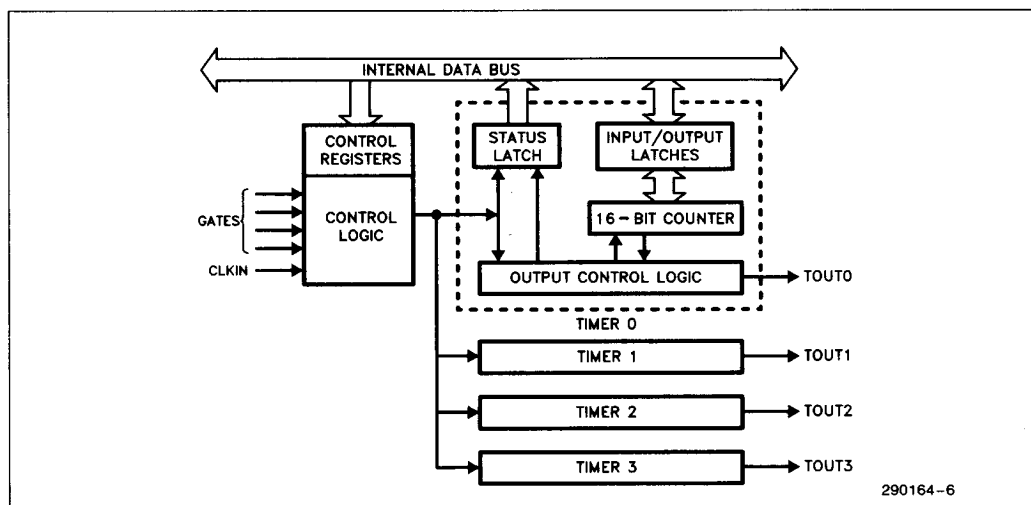

Figure 1-3. Programmable Interval Timers—Block Diagram

Timers 1 and 2 have outputs which are available for general timer/counter purposes as well as special functions. Timer 1 is routed to the refresh control logic to provide refresh timing. Timer 2 is connected to an interrupt request input to provide other timer functions. Timer 3 is a general purpose timer/counter whose output is available to external hardware. It is also connected internally to the interrupt request which defaults to the highest priority (IRQ0).

1.1.3 INTERRUPT CONTROLLER

The 82370 has the equivalent of three enhanced 82C59A Programmable Interrupt Controllers. These controllers can all be operated in the Master Mode, but the priority is always as if they were cascaded. There are 15 interrupt request inputs provided for the user, all of which can be inputs from external slave interrupt controllers. Cascading 82C59As to these request inputs allows a possible total of 120 external interrupt requests. Figure 1-4 is a block diagram of the 82370 Interrupt Controller.

Each of the interrupt request inputs can be individually programmed with its own interrupt vector, allowing more flexibility in interrupt vector mapping than

was available with the 82C59A. An interrupt is provided to alert the system that an attempt is being made to program the vectors in the method of the 82C59A. This provides compatibility of existing software that used the 82C59A or 8259A with new designs using the 82370.

In the event of an unrequested or otherwise erroneous interrupt acknowledge cycle, the 82370 Interrupt Controller issues a default vector. This vector, programmed by the system software, will alert the system of unsolicited interrupts of the 80376.

The functions of the 82370 Interrupt Controller are identical to the 82C59A, except in regards to programming the interrupt vectors as mentioned above. Interrupt request inputs are programmable as either edge or level triggered and are software maskable. Priority can be either fixed or rotating and interrupt requests can be nested.

Enhancements are added to the 82370 for cascading external interrupt controllers. Master to Slave handshaking takes place on the data bus, instead of dedicated cascade lines.

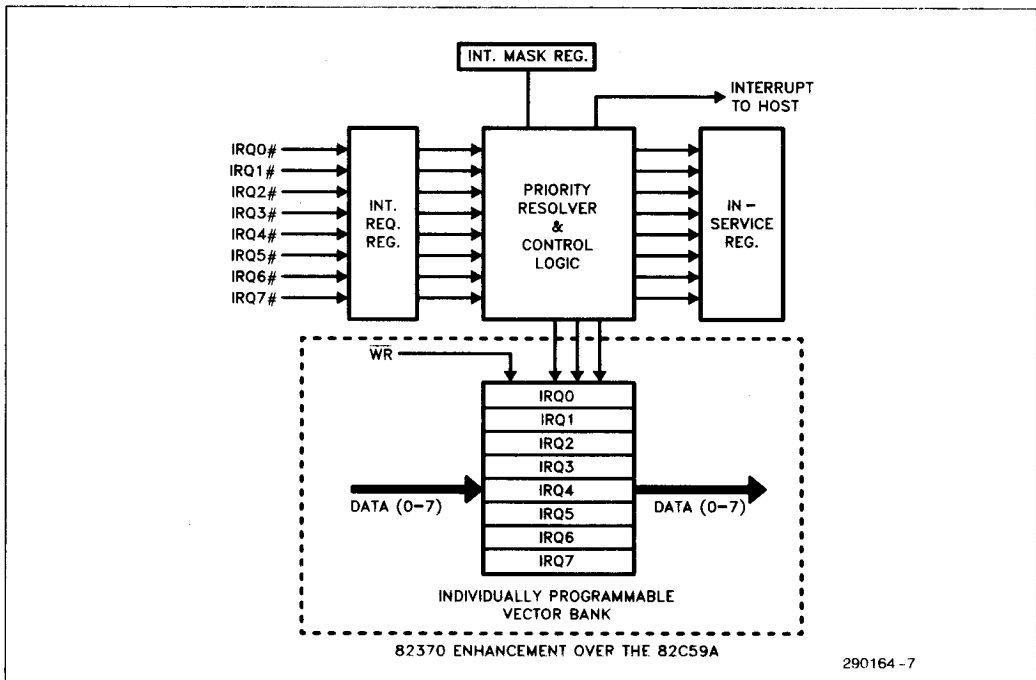

Figure 1-4. 82370 Interrupt Controller—Block Diagram

1.1.4 WAIT STATE GENERATOR

The Wait State Generator is a programmable READY generation circuit for the 80376 bus. A peripheral requiring wait states can request the Wait State Generator to hold the processor's READY input inactive for a predetermined number of bus states. Six different wait state counts can be programmed into the Wait State Generator by software; three for memory accesses and three for I/O accesses. A block diagram of the 82370 Wait State Generator is shown in Figure 1-5.

The peripheral being accessed selects the required wait state count by placing a code on a 2-bit wait state select bus. This code along with the M/IO# signal from the bus master is used to select one of six internal 4-bit wait state registers which has been programmed with the desired number of wait states. From zero to fifteen wait states can be programmed into the wait state registers. The Wait State generator tracks the state of the processor or current bus master at all times, regardless of which device is the current bus master and regardless of whether or not the wait state generator is currently active.

The 82370 Wait State Generator is disabled by making the select inputs both high. This allows hardware which is intelligent enough to generate its own ready signal to be accessed without penalty. As previously mentioned, deselecting the Wait State Generator does not disable its ability to determine the proper number of wait states due to pipeline status in subsequent bus cycles.

The number of wait states inserted into a pipelined bus cycle is the value in the selected wait state register. If the bus master is operating in the non-pipelined mode, the Wait State Generator will increase the number of wait states inserted into the bus cycle by one.

On reset, the Wait State Generator's registers are loaded with the value FFH, giving the maximum number of wait states for any access in which the wait state select inputs are active.

1.1.5 DRAM REFRESH CONTROLLER

The 82370 DRAM Refresh Controller consists of a 24-bit refresh address counter and bus arbitration logic. The output of Timer 1 is used to periodically request a refresh cycle. When the controller receives the request, it requests access to the system bus through the HOLD signal. When bus control is acknowledged by the processor or current bus master, the refresh controller executes a memory read operation at the address currently in the Refresh Address Register. At the same time, it activates a refresh signal (REF#) that the memory uses to force a refresh instead of a normal read. Control of the bus is transferred to the processor at the completion of this cycle. Typically a refresh cycle will take six clock cycles to execute on an 80376 bus.

The 82370 DRAM Refresh Controller has the highest priority when requesting bus access and will interrupt any active DMA process. This allows large blocks of data to be moved by the DMA controller without affecting the refresh function. Also the DMA controller is not required to completely relinquish the bus, the refresh controller simply steals a bus cycle between DMA accesses.

The amount by which the refresh address is incremented is programmable to allow for different bus widths and memory bank arrangements.

1.1.6 CPU RESET FUNCTION

The 82370 contains a special reset function which can respond to hardware reset signals as well as a

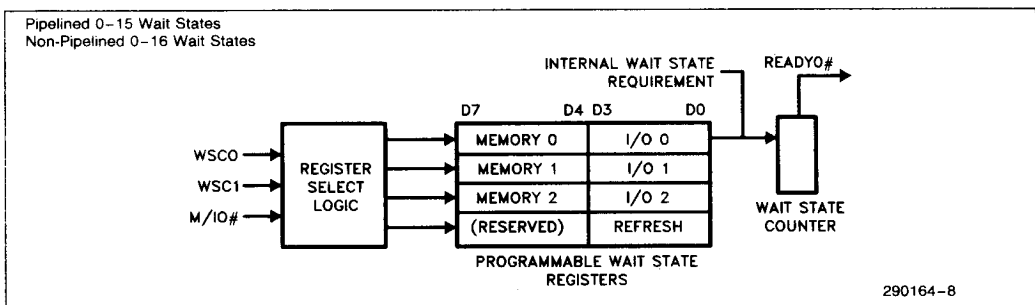

Figure 1-5. 82370 Wait State Generator—Block Diagram

software reset command. The circuit will hold the 80376's RESET line active while an external hardware reset signal is present at its RESET input. It can also reset the 80376 processor as the result of a software command. The software reset command causes the 82370 to hold the processor's RESET line active for a minimum of 62 clock cycles. The 80376 requires that its RESET line be held active for a minimum of 80 clock cycles to re-initialize. For a more detailed explanation and solution, see Appendix D (System Notes).

The 82370 can be programmed to sense the shutdown detect code on the status lines from the 80376. If the Shutdown Detect function is enabled, the 82370 will automatically reset the processor. A diagnostic register is available which can be used to determine the cause of reset.

1.1.7 REGISTER MAP RELOCATION

After a hardware reset, the internal registers of the 82370 are located in I/O space beginning at port address 0000H. The map of the 82370's registers is relocatable via a software command. The default mapping places the 82370 between I/O addresses 0000H and 00DBH. The relocation register allows this map to be moved to any even 256-byte boundary in the processor's 16-bit I/O address space or any even 64 kbyte boundary in the 24-bit memory address space.

1.2 Host Interface

The 82370 is designed to operate efficiently on the local bus of an 80376 microprocessor. The control signals of the 82370 are identical in function to those of the 80376. As a slave, the 82370 operates with all of the features available on the 80376 bus. When the 82370 is in the Master Mode, it looks identical to an 80376 to the connected devices.

The 82370 monitors the bus at all times, and determines whether the current bus cycle is a pipelined or non-pipelined access. All of the status signals of the processor are monitored.

The control, status, and data registers within the 82370 are located at fixed addresses relative to each other, but the group can be relocated to either memory or I/O space and to different locations within those spaces.

As a Slave device, the 82370 monitors the control/status lines of the CPU. The 82370 will generate all of the wait states it needs whenever it is accessed. This allows the programmer the freedom of access-

ing 82370 registers without having to insert NOPs in the program to wait for slower 82370 internal registers.

The 82370 can determine if a current bus cycle is a pipelined or a non-pipelined cycle. It does this by monitoring the ADS#, NA# and READY# signals and thereby keeping track of the current state of the 80376.

As a bus master, the 82370 looks like an 80376 to the rest of the system. This enables the designer greater flexibility in systems which include the 82370. The designer does not have to alter the interfaces of any peripherals designed to operate with the 80376 to accommodate the 82370. The 82370 will access any peripherals on the bus in the same manner as the 80376, including recognizing pipelined bus cycles.

The 82370 is accessed as an 8-bit peripheral. The 80376 places the data of all 8-bit accesses either on D(0-7) or D(8-15). The 82370 will only accept data on these lines when in the Slave Mode. When in the Master Mode, the 82370 is a full 16-bit machine, sending and receiving data in the same manner as the 80376.

2.0 80376 HOST INTERFACE

The 82370 contains a set of interface signals to operate efficiently with the 80376 host processor. These signals were designed so that minimal hardware is needed to connect the 82370 to the 80376. Figure 2-1 depicts a typical system configuration with the 80376 processor. As shown in the diagram, the 82370 is designed to interface directly with the 80376 bus.

Since the 82370 resides on the opposite side of the data bus transceivers with respect to the rest of the system peripherals, it is important to note that the transceivers should be controlled so that contention between the data bus transceivers and the 82370 will not occur. In order to ease the implementation of this, the 82370 activates the CHPSEL# signal which indicates that the 82370 has been addressed and may output data. This signal should be included in the direction and enable control logic of the transceiver. When any of the 82370 internal registers are read, the data bus transceivers should be disabled so that only the 82370 will drive the local bus.

This section describes the basic bus functions of the 82370 to show how this device interacts with the 80376 processor. Other signals which are not directly related to the host interface will be discussed in their associated functional block description.

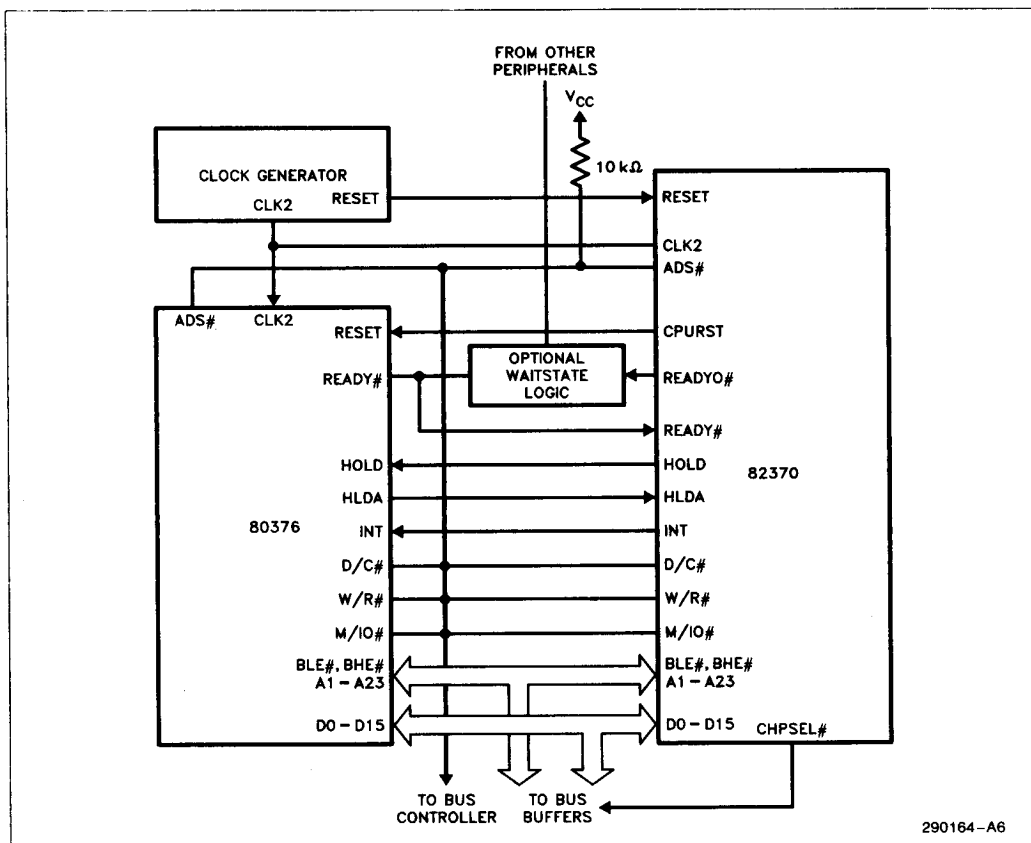

Figure 2-1. 80376/82370 System Configuration

2.1 Master and Slave Modes

At any time, the 82370 acts as either a Slave device or a Master device in the system. Upon reset, the 82370 will be in the Slave Mode. In this mode, the 80376 processor can read/write into the 82370 internal registers. Initialization information may be programmed into the 82370 during Slave Mode.

When DMA service (including DRAM Refresh Cycles generated by the 82370) is requested, the 82370 will request and subsequently get control of the 80376 local bus. This is done through the HOLD and HLDA (Hold Acknowledge) signals. When the 80376 proc-

essor responds by asserting the HLDA signal, the 82370 will switch into Master Mode and perform DMA transfers. In this mode, the 82370 is the bus master of the system. It can read/write data from/to memory and peripheral devices. The 82370 will return to the Slave Mode upon completion of DMA transfers, or when HLDA is negated.

2.2 80376 Interface Signals

As mentioned in the Architecture section, the Bus Interface module of the 82370 (see Figure 1-1) contains signals that are directly connected to the 80376 host processor. This module has separate

16-bit Data and 24-bit Address busses. Also, it has additional control signals to support different bus operations on the system. By residing on the 80376 local bus, the 82370 shares the same address, data and control lines with the processor. The following subsections discuss the signals which interface to the 80376 host processor.

2.2.1 CLOCK (CLK2)

The CLK2 input provides fundamental timing for the 82370. It is divided by two internally to generate the 82370 internal clock. Therefore, CLK2 should be driven with twice the 80376's frequency. In order to maintain synchronization with the 80376 host processor, the 82370 and the 80376 should share a common clock source.

The internal clock consists of two phases: PHI1 and PHI2. Each CLK2 period is a phase of the internal clock. PHI2 is usually used to sample input and set up internal signals and PHI1 is for latching internal data. Figure 2-2 illustrates the relationship of CLK2 and the 82370 internal clock signals. The CPURST signal generated by the 82370 guarantees that the 80376 will wake up in phase with PHI1.

2.2.2 DATA BUS (D₀-D₁₅)

This 16-bit three-state bidirectional bus provides a general purpose data path between the 82370 and the system. These pins are tied directly to the corresponding Data Bus pins of the 80376 local bus. The Data Bus is also used for interrupt vectors generated by the 82370 in the Interrupt Acknowledge cycle.

During Slave I/O operations, the 82370 expects a single byte to be written or read. When the 80376 host processor writes into the 82370, either D₀-D₇ or D₈-D₁₅ will be latched into the 82370, depending

upon whether Byte Enable bit BLE# is 0 or 1 (see Table 2-1). When the 80376 host processor reads from the 82370, the single byte data will be duplicated twice on the Data Bus; i.e. on D₀-D₇ and D₈-D₁₅.

During Master Mode, the 82370 can transfer 16-, and 8-bit data between memory (or I/O devices) and I/O devices (or memory) via the Data Bus.

2.2.3 ADDRESS BUS (A₂₃-A₁)

These three-state bidirectional signals are connected directly to the 80376 Address Bus. In the Slave Mode, they are used as input signals so that the processor can address the 82370 internal ports/registers. In the Master Mode, they are used as output signals by the 82370 to address memory and peripheral devices. The Address Bus is capable of addressing 16 Mbytes of physical memory space (000000H to FFFFFFFH), and 64 Kbytes of I/O addresses.

2.2.4 BYTE ENABLE (BHE#, BLE#)

The Byte Enable pins BHE# and BLE# select the specific byte(s) in the word addressed by A₁-A₂₃. During Master Mode operation, it is used as an output by the 82370 to address memory and I/O locations. The definition of BHE# and BLE# is further illustrated in Table 2-1.

NOTE:

The 82370 will activate BHE# when output in Master Mode. For a more detailed explanation and its solutions, see Appendix D (System Notes).

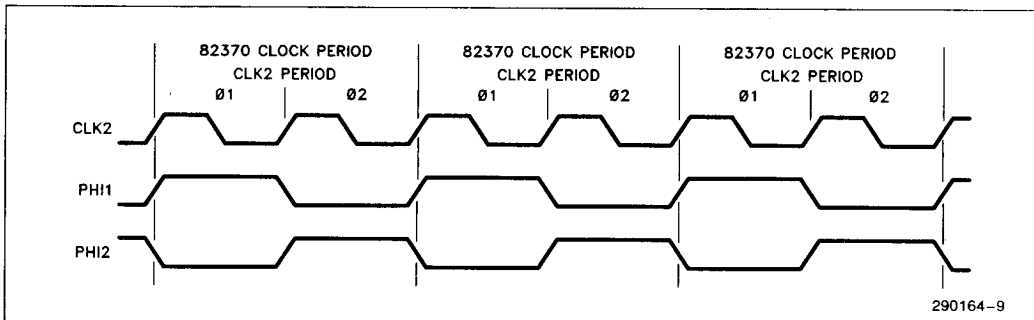

Figure 2-2. CLK2 and 82370 Internal Clock



As an output (Master Mode):

Table 2-1. Byte Enable Signals

| BHE # | BLE # | Byte to be Accessed Relative to A ₂₃ -A ₁ | Logical Byte Presented on Data Bus During WRITE Only* | |
|-------|-------|--|--|--------------------------------|
| | | | D ₁₅ -D ₈ | D ₇ -D ₀ |
| 0 | 0 | 0, 1 | B | A |
| 0 | 1 | 1 | A | A |
| 1 | 0 | 0 | U | A |
| 1 | 1 | (Not Used) | | |

U = Undefined

A = Logical D₀-D₇

B = Logical D₈-D₁₅

***NOTE:**

Actual number of bytes accessed depends upon the programmed data path width.

Table 2-2. Bus Cycle Definition

| M/IO # | D/C # | W/R # | As INPUTS | As OUTPUTS |
|--------|-------|-------|--|---------------|
| 0 | 0 | 0 | Interrupt Acknowledge | NOT GENERATED |
| 0 | 0 | 1 | UNDEFINED | NOT GENERATED |
| 0 | 1 | 0 | I/O Read | I/O Read |
| 0 | 1 | 1 | I/O Write | I/O Write |
| 1 | 0 | 0 | UNDEFINED | NOT GENERATED |
| 1 | 0 | 1 | HALT if A ₁ = 1 SHUTDOWN if A ₁ = 0 | NOT GENERATED |
| 1 | 1 | 0 | Memory Read | Memory Read |
| 1 | 1 | 1 | Memory Write | Memory Write |

2.2.5 BUS CYCLE DEFINITION SIGNALS (D/C#, W/R#, M/IO#)

These three-state bidirectional signals define the type of bus cycle being performed. W/R# distinguishes between write and read cycles. D/C# distinguishes between processor data and control cycles. M/IO# distinguishes between memory and I/O cycles.

During Slave Mode, these signals are driven by the 80376 host processor; during Master Mode, they are driven by the 82370. In either mode, these signals will be valid when the Address Status (ADS#) is driven LOW. Exact bus cycle definitions are given in Table 2-2. Note that some combinations are recognized as inputs, but not generated as outputs. In the Master Mode, D/C# is always HIGH.

2.2.6 ADDRESS STATUS (ADS#)

This signal indicates that a valid address (A₁-A₂₃, BHE#, BLE#) and bus cycle definition (W/R#, D/C#, M/IO#) is being driven on the bus. In the Master Mode, it is driven by the 82370 as an output. In the Slave Mode, this signal is monitored as

an input by the 82370. By the current and past status of ADS# and the READY# input, the 82370 is able to determine, during Slave Mode, if the next bus cycle is a pipelined address cycle. ADS# is asserted during T1 and T2P bus states (see Bus State Definition).

NOTE:

ADS# must be qualified with the rising edge of CLK2.

2.2.7 TRANSFER ACKNOWLEDGE (READY#)

This input indicates that the current bus cycle is complete. In the Master Mode, assertion of this signal indicates the end of a DMA bus cycle. In the Slave Mode, the 82370 monitors this input and ADS# to detect a pipelined address cycle. This signal should be tied directly to the READY# input of the 80376 host processor.

2.2.8 NEXT ADDRESS REQUEST (NA#)

This input is used to indicate to the 82370 in the Master Mode that the system is requesting address

pipelining. When driven LOW by either memory or peripheral devices during Master Mode, it indicates that the system is prepared to accept a new address and bus cycle definition signals from the 82370 before the end of the current bus cycle. If this input is active when sampled by the 82370, the next address is driven onto the bus, provided a bus request is already pending internally.

This input pin is monitored only in the Master Mode. In the Slave Mode, the 82370 uses the ADS# and READY# signals to determine address pipelining cycles, and NA# will be ignored.

2.2.9 RESET (RESET, CPURST)

RESET

This synchronous input suspends any operation in progress and places the 82370 in a known initial state. Upon reset, the 82370 will be in the Slave Mode waiting to be initialized by the 80376 host processor. The 82370 is reset by asserting RESET for 15 or more CLK2 periods. When RESET is asserted, all other input pins are ignored, and all other bus pins are driven to an idle bus state as shown in Table 2-3. The 82370 will determine the phase of its internal clock following RESET going inactive.

RESET is level-sensitive and must be synchronous to the CLK2 signal. The RESET setup and hold time requirements are shown in Figure 2-3.

Table 2-3. Output Signals Following RESET

| Signal | Level |
|--|--------------------|
| A ₁ -A ₂₃ , D ₀ -D ₁₅ , BHE#, BLE# | Float |
| D/C#, W/R#, M/IO#, ADS# | Float |
| READYO# | '1' |
| EOP# | '1' (Weak Pull-UP) |
| EDACK2-EDACK0 | '100' |
| HOLD | '0' |
| INT | UNDEFINED* |
| TOUT1/REF#, TOUT2#/IRQ3#, TOUT3# | UNDEFINED* |
| CPURST | '0' |
| CHPSEL# | '1' |

***NOTE:**

The Interrupt Controller and Programmable Interval Timer are initialized by software commands.

CPURST

This output signal is used to reset the 80376 host processor. It will go active (HIGH) whenever one of the following events occurs: a) 82370's RESET input is active; b) a software RESET command is issued to the 82370; or c) when the 82370 detects a processor Shutdown cycle and when this detection feature is enabled (see CPU Reset and Shutdown Detect). When activated, CPURST will be held active for 62 clocks. The timing of CPURST is such that the 80376 processor will be in synchronization with the 82370. This timing is shown in Figure 2-4.

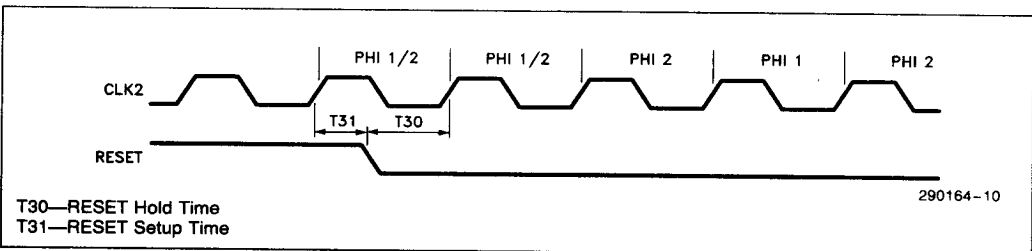

Figure 2-3. RESET Timing

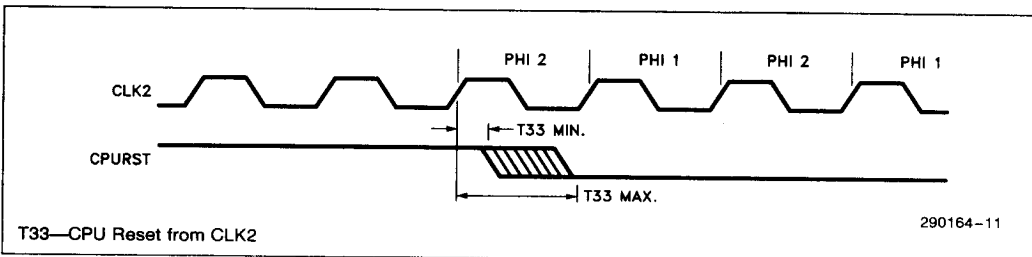

Figure 2-4. CPURST Timing



2.2.10 INTERRUPT OUT (INT)

This output pin is used to signal the 80376 host processor that one or more interrupt requests (either internal or external) are pending. The processor is expected to respond with an Interrupt Acknowledge cycle. This signal should be connected directly to the Maskable Interrupt Request (INTR) input of the 80376 host processor.

2.3 82370 Bus Timing

The 82370 internally divides the CLK2 signal by two to generate its internal clock. Figure 2-2 showed the relationship of CLK2 and the internal clock which consists of two phases: PHI1 and PHI2. Each CLK2 period is a phase of the internal clock.

In the 82370, whether it is in the Master or Slave Mode, the shortest time unit of bus activity is a bus state. A bus state, which is also referred as a 'T-state', is defined as one 82370 PHI2 clock period (i.e. two CLK2 periods). Recall in Table 2-2 various types of bus cycles in the 82370 are defined by the M/IO#, D/C# and W/R# signals. Each of these bus cycles is composed of two or more bus states. The length of a bus cycle depends on when the READY# input is asserted (i.e. driven LOW).

2.3.1 ADDRESS PIPELINING

The 82370 supports Address Pipelining as an option in both the Master and Slave Mode. This feature typically allows a memory or peripheral device to operate with one less wait state than would otherwise be required. This is possible because during a pipelined cycle, the address and bus cycle definition of the next cycle will be generated by the bus master while waiting for the end of the current cycle to be acknowledged. The pipelined bus is especially well suited for an interleaved memory environment. For 16 MHz interleaved memory designs with 100 ns access time DRAMs, zero wait state memory accesses can be achieved when pipelined addressing is selected.

In the Master Mode, the 82370 is capable of initiating, on a cycle-by-cycle basis, either a pipelined or non-pipelined access depending upon the state of the NA# input. If a pipelined cycle is requested (indicated by NA# being driven LOW), the 82370 will drive the address and bus cycle definition of the next cycle as soon as there is an internal bus request pending.

In the Slave Mode, the 82370 is constantly monitoring the ADS# and READY# signals on the processor local bus to determine if the current bus cycle is

a pipelined cycle. If a pipelined cycle is detected, the 82370 will request one less wait state from the processor if the Wait State Generator feature is selected. On the other hand, during an 82370 internal register access in a pipelined cycle, it will make use of the advance address and bus cycle information. In all cases, Address Pipelining will result in a savings of one wait state.

2.3.2 MASTER MODE BUS TIMING

When the 82370 is in the Master Mode, it will be in one of six bus states. Figure 2-5 shows the complete bus state diagram of the Master Mode, including pipelined address states. As seen in the figure, the 82370 state diagram is very similar to that of the 80376. The major difference is that in the 82370, there is no Hold state. Also, in the 82370, the conditions for some state transitions depend upon whether it is the end of a DMA process.

NOTE:

The term 'end of a DMA process' is loosely defined here. It depends on the DMA modes of operation as well as the state of the EOP# and DREQ inputs. This is explained in detail in section 3—DMA Controller.

The 82370 will enter the idle state, T_i, upon RESET and whenever the internal address is not available at the end of a DMA cycle or at the end of a DMA process. When address pipelining is not used (NA# is not asserted), a new bus cycle always begins with state T₁. During T₁, address and bus cycle definition signals will be driven on the bus. T₁ is always followed by T₂.

If a bus cycle is not acknowledged (with READY#) during T₂ and NA# is negated, T₂ will be repeated. When the end of the bus cycle is acknowledged during T₂, the following state will be T₁ of the next bus cycle (if the internal address latch is loaded and if this is not the end of the DMA process). Otherwise, the T_i state will be entered. Therefore, if the memory or peripheral accessed is fast enough to respond within the first T₂, the fastest non-pipelined cycle will take one T₁ and one T₂ state.

Use of the address pipelining feature allows the 82370 to enter three additional bus states: T_{1P}, T_{2P} and T_{2i}. T_{1P} is the first bus state of a pipelined bus cycle. T_{2P} follows T_{1P} (or T₂) if NA# is asserted when sampled. The 82370 will drive the bus with the address and bus cycle definition signals of the next cycle during T_{2P}. From the state diagram, it can be seen that after an idle state T_i, the first bus cycle must begin with T₁, and is therefore a non-pipelined bus cycle. The next bus cycle can be pipelined if

NA# is asserted and the previous bus cycle ended in a T2P state. Once the 82370 is in a pipelined cycle and provided that NA# is asserted in subsequent cycles, the 82370 will be switching between T1P and T2P states. If the end of the current bus cycle is not acknowledged by the READY# input, the 82370 will extend the cycle by adding T2P states. The fastest pipelined cycle will consist of one T1P and one T2P state.

The 82370 will enter state T2i when NA# is asserted and when one of the following two conditions occurs. The first condition is when the 82370 is in state T2. T2i will be entered if READY# is not asserted and there is no next address available. This situation is similar to a wait state. The 82370 will stay in T2i for as long as this condition exists. The second condition which will cause the 82370 to enter T2i is when the 82370 is in state T1P. Before going to state T2P, the 82370 needs to wait in state T2i until the next address is available. Also, in both cases, if the DMA process is complete, the 82370 will enter the T2i state in order to finish the current DMA cycle.

Figure 2-6 is a timing diagram showing non-pipelined bus accesses in the Master Mode. Figure 2-7 shows the timing of pipelined accesses in the Master Mode.

2.3.3 SLAVE MODE BUS TIMING

Figure 2-8 shows the Slave Mode bus timing in both pipelined and non-pipelined cycles when the 82370 is being accessed. Recall that during Slave Mode, the 82370 will constantly monitor the ADS# and READY# signals to determine if the next cycle is pipelined. In Figure 2-8, the first cycle is non-pipelined and the second cycle is pipelined. In the pipelined cycle, the 82370 will start decoding the address and bus cycle signals one bus state earlier than in a non-pipelined cycle.

The READY# input signal is sampled by the 80376 host processor to determine the completion of a bus cycle. This occurs during the end of every T2, T2i and T2P state. Normally, the output of the 82370 Wait State Generator, READYO#, is directly connected to the READY# input of the 80376 host processor and the 82370. In such case, READYO# and READY# will be identical (see Wait State Generator).

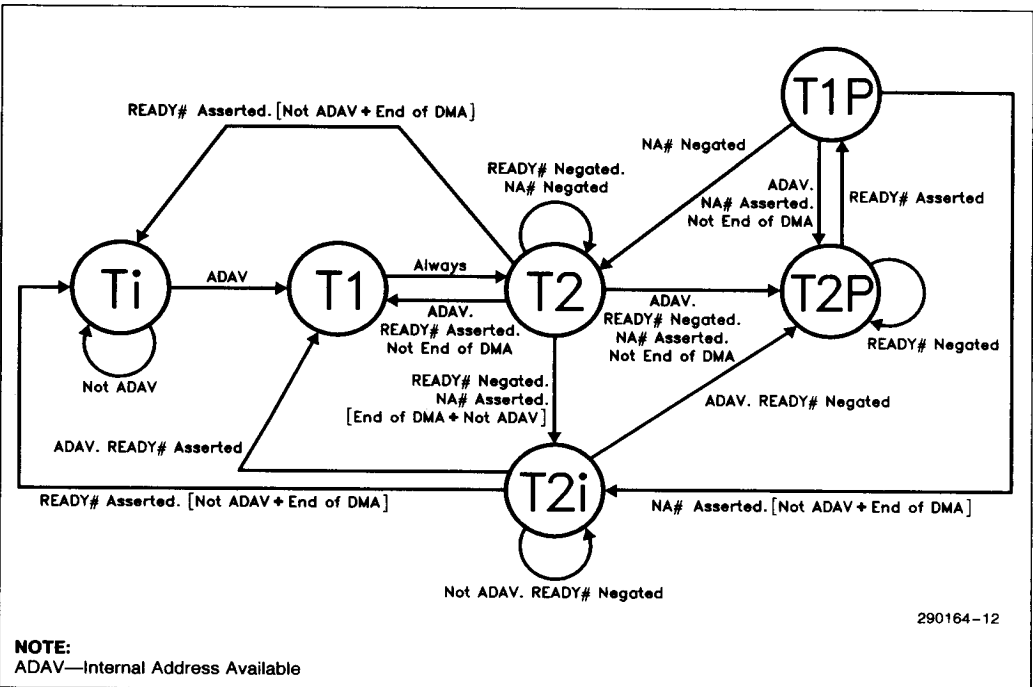

Figure 2-5. Master Mode State Diagram

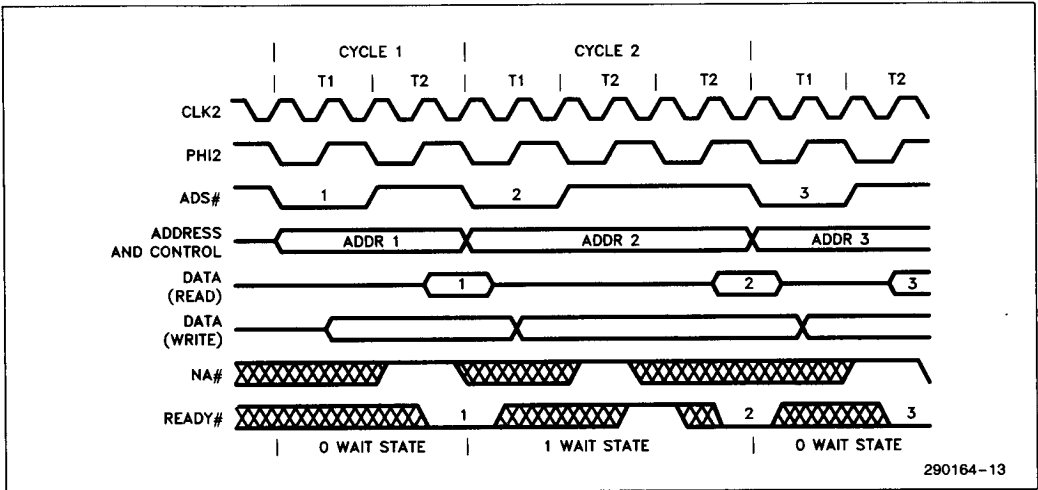

Figure 2-6. Non-Pipelined Bus Cycles

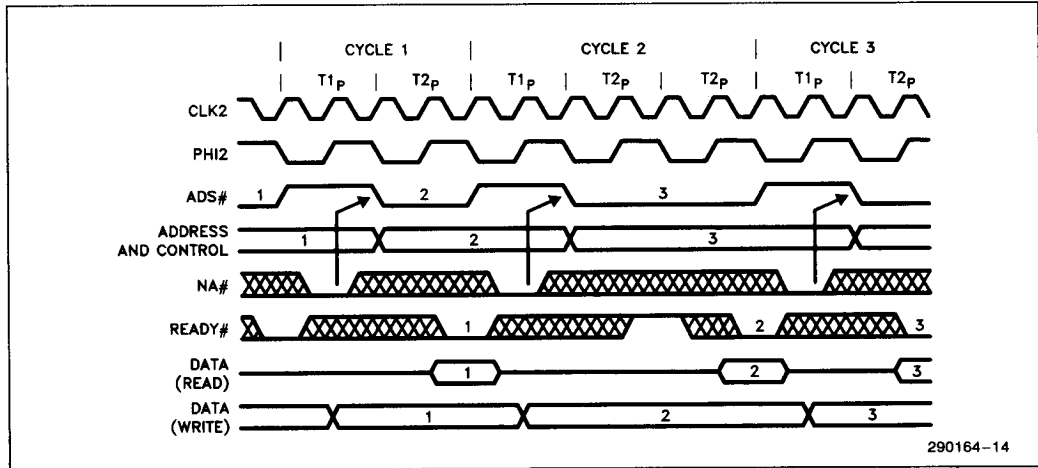

Figure 2-7. Pipelined Bus Cycles

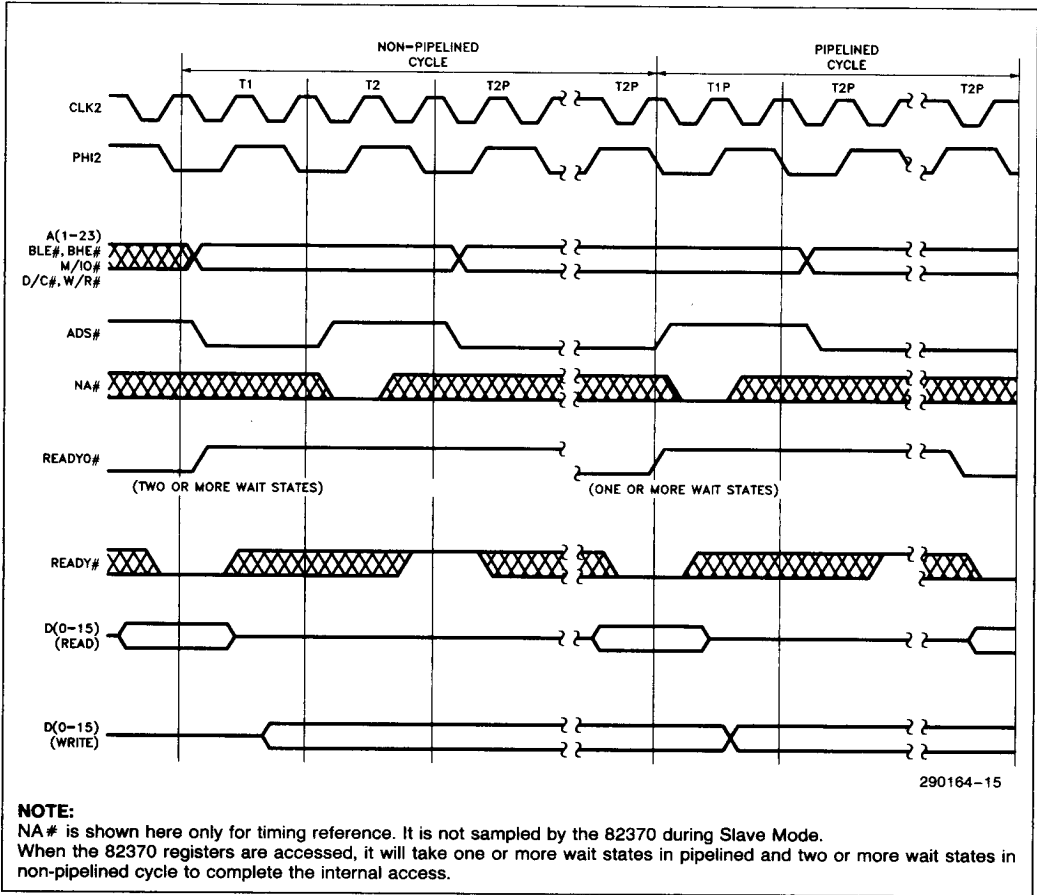

Figure 2-8. Slave Read/Write Timing

3.0 DMA CONTROLLER

The 82370 DMA Controller is capable of transferring data between any combination of memory and/or I/O, with any combination of data path widths. The 82370 DMA Controller can be programmed to accommodate 8- or 16-bit devices. With its 16-bit external data path, it can transfer data in units of byte or a word. Bus bandwidth is optimized through the use of an internal temporary register which can disassemble or assemble data to or from either an aligned or non-aligned destination or source. Figure 3-1 is a block diagram of the 82370 DMA Controller.

The 82370 has eight channels of DMA. Each channel operates independently of the others. Within the operation of the individual channels, there are many different modes of data transfer available. Many of the operating modes can be intermixed to provide a very versatile DMA controller.

3.1 Functional Description

In describing the operation of the 82370's DMA Controller, close attention to terminology is required. Be-

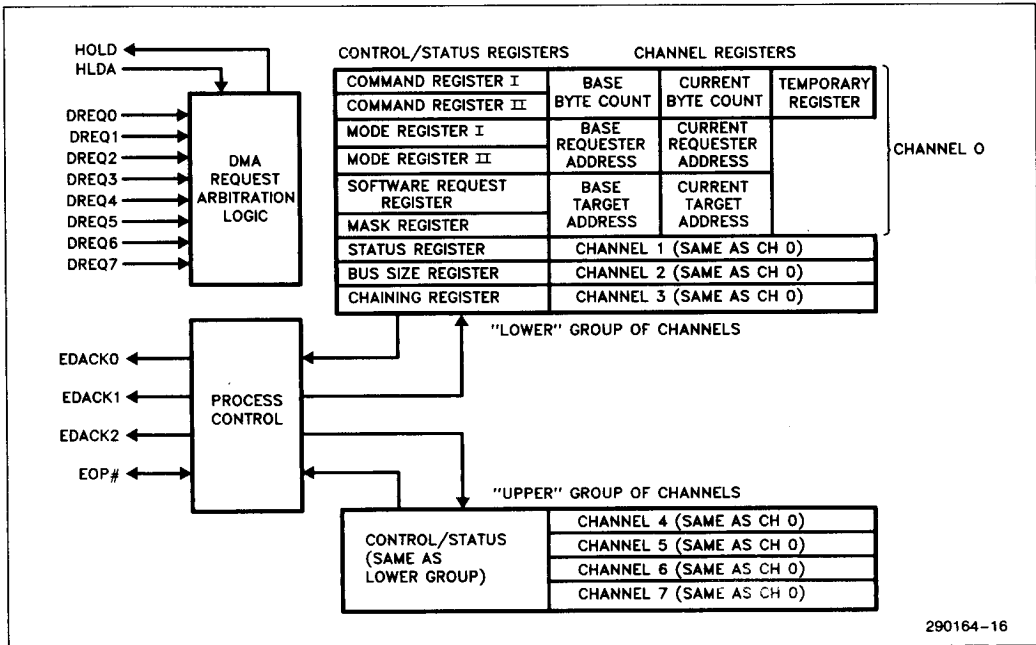

Figure 3-1. 82370 DMA Controller Block Diagram

fore entering the discussion of the function of the 82370 DMA Controller, the following explanations of some of the terminology used herein may be of benefit. First, a few terms for clarification:

DMA PROCESS—A DMA process is the execution of a programmed DMA task from beginning to end. Each DMA process requires initial programming by the host 80376 microprocessor.

BUFFER—A contiguous block of data.

BUFFER TRANSFER—The action required by the DMA to transfer an entire buffer.

DATA TRANSFER—The DMA action in which a group of bytes or words are moved between devices by the DMA Controller. A data transfer operation may involve movement of one or many bytes.

BUS CYCLE—Access by the DMA to a single byte or word.

Each DMA channel consists of three major components. These components are identified by the contents of programmable registers which define the

memory or I/O devices being serviced by the DMA. They are the Target, the Requester, and the Byte Count. They will be defined generically here and in greater detail in the DMA register definition section.

The Requester is the device which requires service by the 82370 DMA Controller, and makes the request for service. All of the control signals which the DMA monitors or generates for specific channels are logically related to the Requester. Only the Requester is considered capable of initiating or terminating a DMA process.

The Target is the device with which the Requester wishes to communicate. As far as the DMA process is concerned, the Target is a slave which is incapable of control over the process.

The direction of data transfer can be either from Requester to Target or from Target to Requester; i.e. each can be either a source or a destination.

The Requester and Target may each be either I/O or memory. Each has an address associated with it that can be incremented, decremented, or held constant. The addresses are stored in the Requester

Address Registers and Target Address Registers, respectively. These registers have two parts: one which contains the current address being used in the DMA process (Current Address Register), and one which holds the programmed base address (Base Address Register). The contents of the Base Registers are never changed by the 82370 DMA Controller. The Current Registers are incremented or decremented according to the progress of the DMA process.

The Byte Count is the component of the DMA process which dictates the amount of data which must be transferred. Current and Base Byte Count Registers are provided. The Current Byte Count Register is decremented once for each byte transferred by the DMA process. When the register is decremented past zero, the Byte Count is considered 'expired' and the process is terminated or restarted, depending on the mode of operation of the channel. The point at which the Byte Count expires is called 'Terminal Count' and several status signals are dependent on this event.

Each channel of the 82370 DMA Controller also contains a 32-bit Temporary Register for use in assembling and disassembling non-aligned data. The operation of this register is transparent to the user, although the contents of it may affect the timing of some DMA handshake sequences. Since there is data storage available for each channel, the DMA Controller can be interrupted without loss of data.

To avoid unexpected results, care should be taken in programming the byte count correctly when assembling and disassembling non-aligned data. For example:

Words to Bytes:

Transferring two words to bytes, but setting the byte count to three, will result in three bytes transferred and the final byte flushed.

Bytes to Words:

Transferring six bytes to three words, but setting the byte count to five, will result in the sixth byte transferred being undefined.

The 82370 DMA Controller is a slave on the bus until a request for DMA service is received via either a software request command or a hardware request signal. The host processor may access any of the control/status or channel registers at any time the 82370 is a bus slave. Figure 3-2 shows the flow of operations that the DMA Controller performs.

At the time a DMA service request is received, the DMA Controller issues a bus hold request to the host processor. The 82370 becomes the bus master when the host relinquishes the bus by asserting a

hold acknowledge signal. The channel to be serviced will be the one with the highest priority at the time the DMA Controller becomes the bus master. The DMA Controller will remain in control of the bus until the hold acknowledge signal is removed, or until the current DMA transfer is complete.

While the 82370 DMA Controller has control of the bus, it will perform the required data transfer(s). The type of transfer, source and destination addresses, and amount of data to transfer are programmed in the control registers of the DMA channel which received the request for service.

At completion of the DMA process, the 82370 will remove the bus hold request. At this time the 82370 becomes a slave again, and the host returns to being a master. If there are other DMA channels with requests pending, the controller will again assert the hold request signal and restart the bus arbitration and switching process.

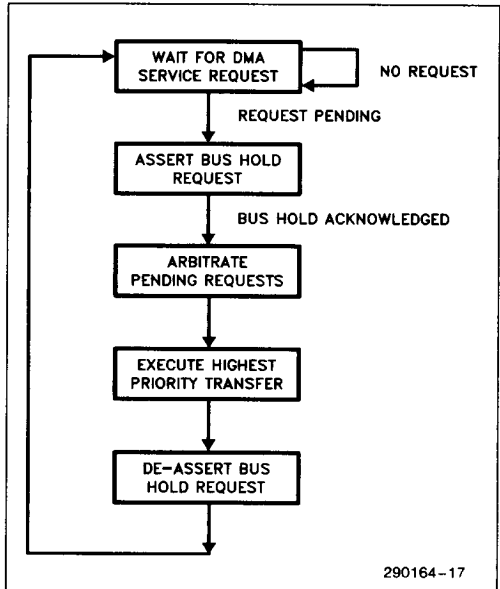

Figure 3-2. Flow of DMA Controller Operation

3.2 Interface Signals

There are fourteen control signals dedicated to the DMA process. They include eight DMA Channel Requests (DREQn), three Encoded DMA Acknowledge signals (EDACKn), Processor Hold and Hold Ac-

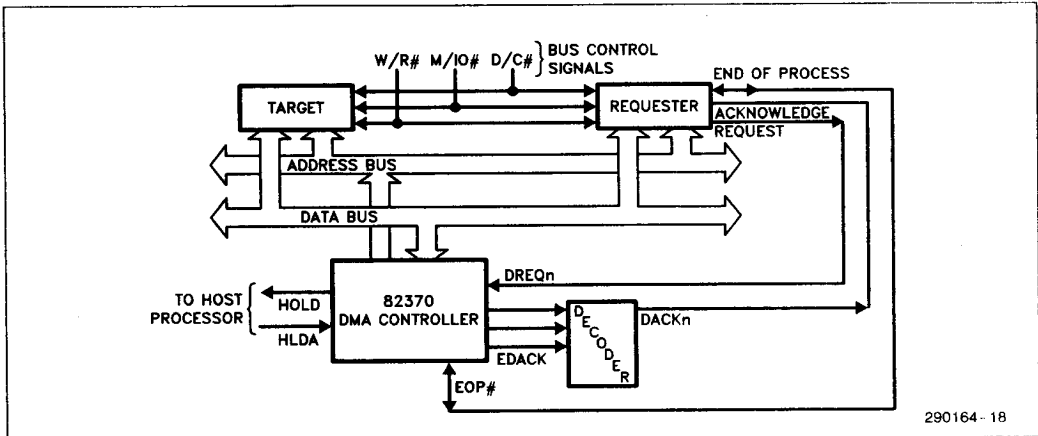

Figure 3-3. Requester, Target and DMA Controller Interconnection

knowledge (HOLD, HLDA), and End-of-Process (EOP#). The DREQn inputs and EDACK (0–2) outputs are handshake signals to the devices requiring DMA service. The HOLD output and HLDA input are handshake signals to the host processor. Figure 3-3 shows these signals and how they interconnect between the 82370 DMA Controller, and the Requester and Target devices.

3.2.1 DREQn and EDACK (0–2)

These signals are the handshake signals between the peripheral and the 82370. When the peripheral requires DMA service, it asserts the DREQn signal of the channel which is programmed to perform the service. The 82370 arbitrates the DREQn against other pending requests and begins the DMA process after finishing other higher priority processes.

When the DMA service for the requested channel is in progress, the EDACK (0–2) signals represent the DMA channel which is accessing the Requester. The 3-bit code on the EDACK (0–2) lines indicates the number of the channel presently being serviced. Table 3-2 shows the encoding of these signals. Note that Channel 4 does not have a corresponding hardware acknowledge.

The DMA acknowledge (EDACK) signals indicate the active channel only during DMA accesses to the Requester. During accesses to the Target, EDACK (0–2) has the idle code (100). EDACK (0–2) can thus be used to select a Requester device during a transfer.

DREQn can be programmed as either an Asynchronous or Synchronous input. See section 3.4.1 for details on synchronous versus asynchronous operation of these pins.

Table 3-2. EDACK Encoding During a DMA Transfer

| EDACK2 | EDACK1 | EDACK0 | Active Channel |
|--------|--------|--------|----------------|
| 0 | 0 | 0 | 0 |
| 0 | 0 | 1 | 1 |
| 0 | 1 | 0 | 2 |
| 0 | 1 | 1 | 3 |
| 1 | 0 | 0 | Target Access |
| 1 | 0 | 1 | 5 |
| 1 | 1 | 0 | 6 |
| 1 | 1 | 1 | 7 |

The EDACKn signals are always active. They either indicate 'no acknowledge' or they indicate a bus access to the requester. The acknowledge code is either 100, for an idle DMA or during a DMA access to the Target, or 'n' during a Requester access, where n is the binary value representing the channel. A simple 3-line to 8-line decoder can be used to provide discrete acknowledge signals for the peripherals.

3.2.2 HOLD AND HLDA

The Hold Request (HOLD) and Hold Acknowledge (HLDA) signals are the handshake signals between the DMA Controller and the host processor. HOLD is an output from the 82370 and HLDA is an input. HOLD is asserted by the DMA Controller when there is a pending DMA request, thus requesting the processor to give up control of the bus so the DMA process can take place. The 80376 responds by asserting HLDA when it is ready to relinquish control of the bus.

The 82370 will begin operations on the bus one clock cycle after the HLDA signal goes active. For this reason, other devices on the bus should be in the slave mode when HLDA is active.

HOLD and HLDA should not be used to gate or select peripherals requesting DMA service. This is because of the use of DMA-like operations by the DRAM Refresh Controller. The Refresh Controller is arbitrated with the DMA Controller for control of the bus, and refresh cycles have the highest priority. A refresh cycle will take place between DMA cycles without relinquishing bus control. See section 3.4.3 for a more detailed discussion of the interaction between the DMA Controller and the DRAM Refresh Controller.

3.2.3 EOP#

EOP# is a bi-directional signal used to indicate the end of a DMA process. The 82370 activates this as an output during the T2 states of the last Requester bus cycle for which a channel is programmed to execute. The Requester should respond by either withdrawing its DMA request, or interrupting the host processor to indicate that the channel needs to be programmed with a new buffer. As an input, this signal is used to tell the DMA Controller that the peripheral being serviced does not require any more data to be transferred. This indicates that the current buffer is to be terminated.

EOP# can be programmed as either an Asynchronous or a Synchronous input. See section 3.4.1 for details on synchronous versus asynchronous operation of this pin.

3.3 Modes of Operation

The 82370 DMA Controller has many independent operating functions. When designing peripheral interfaces for the 82370 DMA Controller, all of the functions or modes must be considered. All of the channels are independent of each other (except in priority of operation) and can operate in any of the modes. Many of the operating modes, though independently programmable, affect the operation of other modes. Because of the large number of combinations possible, each programmable mode is discussed here with its affects on the operation of other modes. The entire list of possible combinations will not be presented.

Table 3-1 shows the categories of DMA features available in the 82370. Each of the five major categories is independent of the others. The sub-categories are the available modes within the major func-

Table 3-1. DMA Operating Modes

| |
|------------------------------------|
| I. TARGET/REQUESTER DEFINITION |
| a. Data Transfer Direction |
| b. Device Type |
| II. BUFFER PROCESSES |
| a. Single Buffer Process |
| b. Buffer Auto-Initialize Process |
| c. Buffer Chaining Process |
| III. DATA TRANSFER/HANDSHAKE MODES |
| a. Single Transfer Mode |
| b. Demand Transfer Mode |
| c. Block Transfer Mode |
| d. Cascade Mode |
| IV. PRIORITY ARBITRATION |
| a. Fixed |
| b. Rotating |
| c. Programmable Fixed |
| V. BUS OPERATION |
| a. Fly-By (Single-Cycle)/Two-Cycle |
| b. Data Path Width |
| c. Read, Write, or Verify Cycles |



tion or mode category. The following sections explain each mode or function and its relation to other features.

3.3.1 TARGET/REQUESTER DEFINITION

All DMA transfers involve three devices: the DMA Controller, the Requester, and the Target. Since the devices to be accessed by the DMA Controller vary widely, the operating characteristics of the DMA Controller must be tailored to the Requester and Target devices.

The Requester can be defined as either the source or the destination of the data to be transferred. This is done by specifying a Write or a Read transfer, respectively. In a Read transfer, the Target is the data source and the Requester is the destination for the data. In a Write transfer, the Requester is the source and the Target is the destination.

The Requester and Target addresses can each be independently programmed to be incremented, decremented, or held constant. As an example, the 82370 is capable of reversing a string of data by having the Requester address increment and the Target address decrement in a memory-to-memory transfer.

3.3.2 BUFFER TRANSFER PROCESSES

The 82370 DMA Controller allows three programmable Buffer Transfer Processes. These processes define the logical way in which a buffer of data is accessed by the DMA.

The three Buffer Transfer Processes include the Single Buffer Process, the Buffer Auto-Initialize Process, and the Buffer Chaining Process. These processes require special programming considerations. See the DMA Programming section for more details on setting up the Buffer Transfer Processes.

Single Buffer Process

The Single Buffer Process allows the DMA channel to transfer only one buffer of data. When the buffer has been completely transferred (Current Byte Count decremented past zero or EOP# input active), the DMA process ends and the channel becomes idle. In order for that channel to be used again, it must be reprogrammed.

The Single Buffer Process is usually used when the amount of data to be transferred is known exactly, and it is also known that there is not likely to be any data to follow before the operating system can reprogram the channel.

Buffer Auto-Initialize Process

The Buffer Auto-Initialize Process allows multiple groups of data to be transferred to or from a single buffer. This process does not require reprogramming. The Current Registers are automatically reprogrammed from the Base Registers when the current process is terminated, either by an expired Byte Count or by an external EOP# signal. The data transferred will always be between the same Target and Requester.

The auto-initialization/process-execution cycle is repeated until the channel is either disabled or reprogrammed.

Buffer Chaining Process

The Buffer Chaining Process is useful for transferring large quantities of data into non-contiguous buffer areas. In this process, a single channel is used to process data from several buffers, while having to program the channel only once. Each new buffer is programmed in a pipelined operation that provides the new buffer information while the old buffer is being processed. The chain is created by loading new buffer information while the 82370 DMA Controller is processing the Current Buffer. When the Current Buffer expires, the 82370 DMA Controller automatically restarts the channel using the new buffer information.

Loading the new buffer information is done by an interrupt routine which is requested by the 82370. Interrupt Request 1 (IRQ1) is tied internally to the 82370 DMA Controller for this purpose. IRQ1 is generated by the 82370 when the new buffer information is loaded into the channel's Current Registers, leaving the Base Registers 'empty'. The interrupt service routine loads new buffer information into the Base Registers. The host processor is required to load the information for another buffer before the current Byte Count expires. The process repeats until the host programs the channel back to single buffer operation, or until the channel runs out of buffers.

The channel runs out of buffers when the Current Buffer expires and the Base Registers have not yet been loaded with new buffer information. When this occurs, the channel must be reprogrammed.

If an external EOP# is encountered while executing a Buffer Chaining Process, the current buffer is considered expired and the new buffer information is loaded into the Current Registers. If the Base Registers are 'empty', the chain is terminated.

The channel uses the Base Target Address Register as an indicator of whether or not the Base Registers are full. When the most significant byte of the Base Target Register is loaded, the channel considers all of the Base Registers loaded, and removes the interrupt request. This requires that the other Base Registers (Base Requester Address, Base Byte Count) must be loaded before the Base Target Address Register. The reason for implementing the re-loading process this way is that, for most applications, the Byte Count and the Requester will not change from one buffer to the next, and therefore do not need to be reprogrammed. The details of programming the channel for the Buffer Chaining Process can be found in the section on DMA programming.

3.3.3 DATA TRANSFER MODES

Three Data Transfer modes are available in the 82370 DMA Controller. They are the Single Transfer, Block Transfer, and Demand Transfer Modes. These transfer modes can be used in conjunction with any one of three Buffer Transfer modes: Single Buffer, Auto-Initialized Buffer and Buffer Chaining. Any Data Transfer Mode can be used under any of the Buffer Transfer Modes. These modes are independently available for all DMA channels.

Different devices being serviced by the DMA Controller require different handshaking sequences for data transfers to take place. Three handshaking modes are available on the 82370, giving the designer the opportunity to use the DMA Controller as efficiently as possible. The speed at which data can

be presented or read by a device can affect the way a DMA Controller uses the host's bus, thereby affecting not only data throughput during the DMA process, but also affecting the host's performance by limiting its access to the bus.

Single Transfer Mode

In the Single Transfer Mode, one data transfer to or from the Requester is performed by the DMA Controller at a time. The DREQn input is arbitrated and the HOLD/HLDA sequence is executed for each transfer. Transfers continue in this manner until the Byte Count expires, or until EOP# is sampled active. If the DREQn input is held active continuously, the entire DREQ-HOLD-HLDA-DACK sequence is repeated over and over until the programmed number of bytes has been transferred. Bus control is released to the host between each transfer. Figure 3-4 shows the logical flow of events which make up a buffer transfer using the Single Transfer Mode. Refer to section 3.4 for an explanation of the bus control arbitration procedure.

The Single Transfer Mode is used for devices which require complete handshake cycles with each data access. Data is transferred to or from the Requester only when the Requester is ready to perform the transfer. Each transfer requires the entire DREQ-

HOLD-HLDA-DACK handshake cycle. Figure 3-5 shows the timing of the Single Transfer Mode cycle.

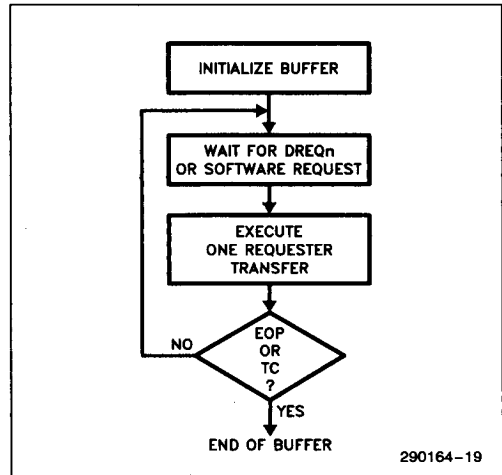
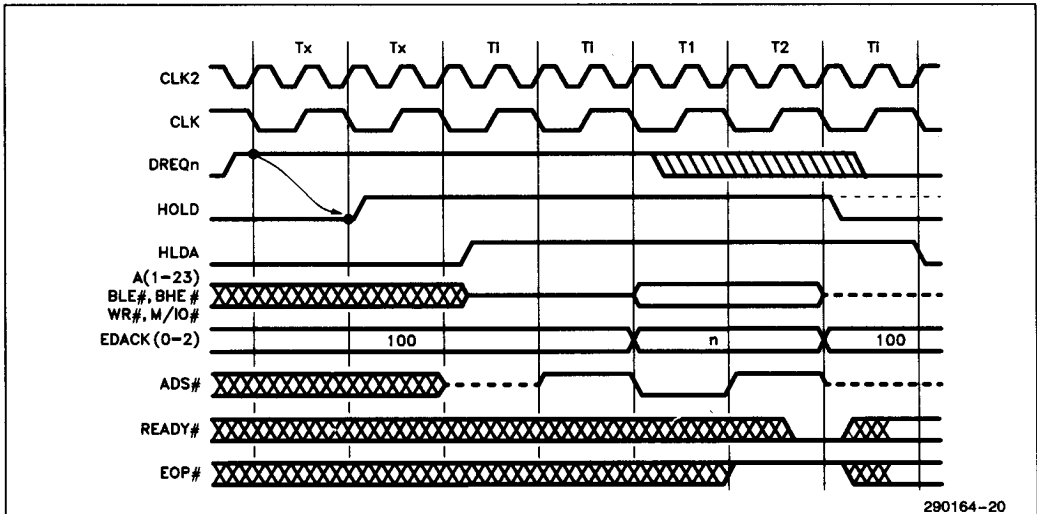

Figure 3-4. Buffer Transfer in Single Transfer Mode



NOTE:

The Single Transfer Mode is more efficient (15%–20%) in the case where the source is the Target. Because of the internal pipeline of the 82370 DMA Controller, two idle states are added at the end of a transfer in the case where the source is the Requester.

Figure 3-5. DMA Single Transfer Mode

Block Transfer Mode

In the Block Transfer Mode, the DMA process is initiated by a DMA request and continues until the Byte Count expires, or until EOP# is activated by the Requester. The DREQn signal need only be held active until the first Requester access. Only a refresh cycle will interrupt the block transfer process.

Figure 3-6 illustrates the operation of the DMA during the Block Transfer Mode. Figure 3-7 shows the timing of the handshake signals during Block Mode Transfers.

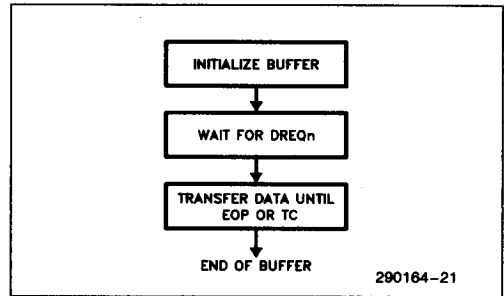

**Figure 3-6. Buffer Transfer
In Block Transfer Mode**

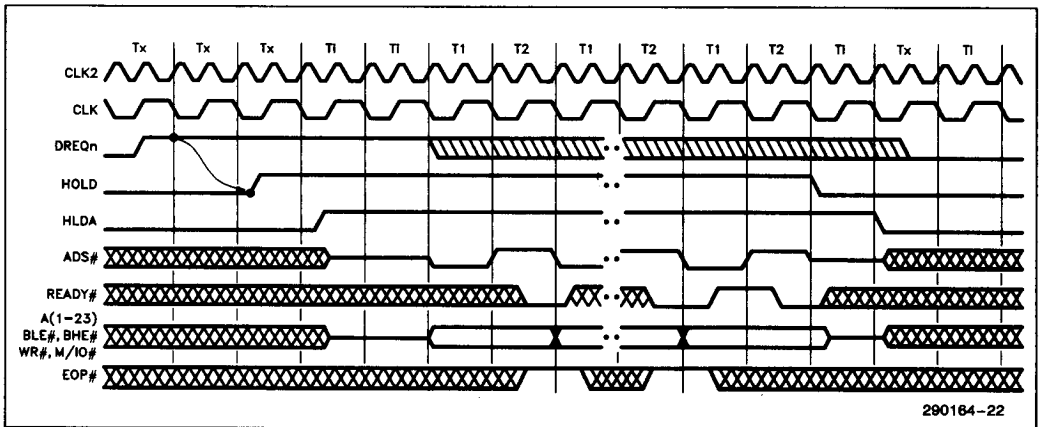

Figure 3-7. Block Mode Transfers

Demand Transfer Mode

The Demand Transfer Mode provides the most flexible handshaking procedures during the DMA process. A Demand Transfer is initiated by a DMA request. The process continues until the Byte Count expires, or an external EOP# is encountered. If the device being serviced (Requester) desires, it can interrupt the DMA process by de-activating the DREQn line. Action is taken on the condition of DREQn during Requester accesses only. The access during which DREQn is sampled inactive is the last Requester access which will be performed during the current transfer. Figure 3-8 shows the flow of events during the transfer of a buffer in the Demand Mode.

When the DREQn line goes inactive, the DMA Controller will complete the current transfer, including any necessary accesses to the Target, and relinquish control of the bus to the host. The current process information is saved (byte count, Requester and Target addresses, and Temporary Register).

The Requester can restart the transfer process by reasserting DREQn. The 82370 will arbitrate the request with other pending requests and begin the process where it left off. Figure 3-9 shows the timing of handshake signals during Demand Transfer Mode operation.

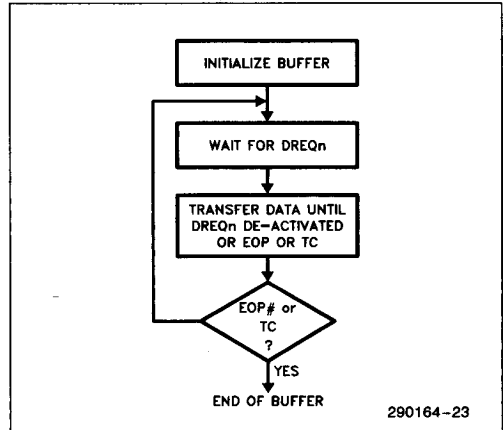

Figure 3-8. Buffer Transfer in Demand Transfer Mode

1

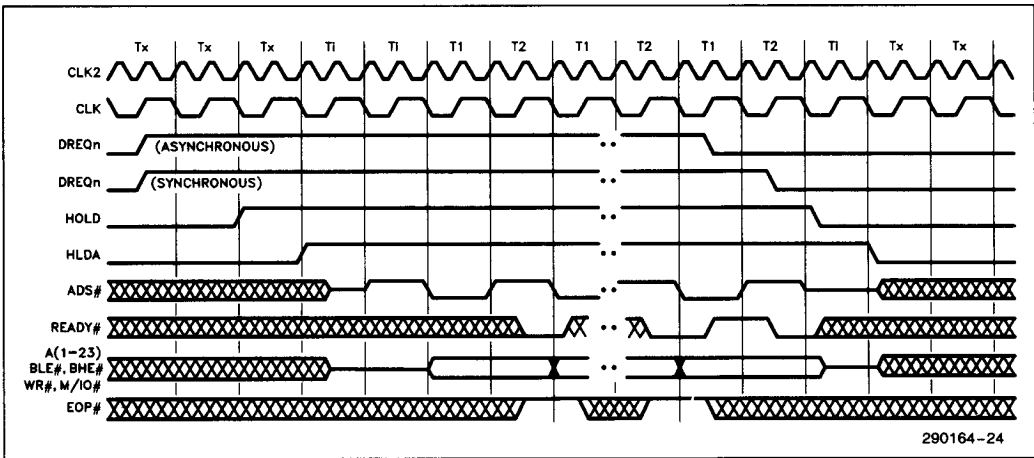

Figure 3-9. Demand Mode Transfers

Using the Demand Transfer Mode allows peripherals to access memory in small, irregular bursts without wasting bus control time. The 82370 is designed to give the best possible bus control latency in the Demand Transfer Mode. Bus control latency is defined here as the time from the last active bus cycle of the previous bus master to the first active bus cycle of the new bus master. The 82370 DMA Controller will perform its first bus access cycle two bus states after HLDA goes active. In the typical configuration, bus control is returned to the host one bus state after the DREQn goes inactive.

There are two cases where there may be more than one bus state of bus control latency at the end of a transfer. The first is at the end of an Auto-Initialize process, and the second is at the end of a process where the source is the Requester and Two-Cycle transfers are used.

When a Buffer Auto-Initialize Process is complete, the 82370 requires seven bus states to reload the Current Registers from the Base Registers of the Auto-Initialized channel. The reloading is done while the 82370 is still the bus master so that it is prepared to service the channel immediately after relinquishing the bus, if necessary.

In the case where the Requester is the source, and Two-Cycle transfers are being used, there are two extra idle states at the end of the transfer process. This occurs due to the housekeeping in the DMA's internal pipeline. These two idle states are present only after the very last Requester access, before the DMA Controller de-activates the HOLD signal.

3.3.4 CHANNEL PRIORITY ARBITRATION

DMA channel priority can be programmed into one of two arbitration methods: Fixed or Rotating. The four lower DMA channels and the four upper DMA channels operate as if they were two separate DMA controllers operating in cascade. The lower group of four channels (0-3) is always prioritized between channels 7 and 4 of the upper group of channels (4-7). Figure 3-10 shows a pictorial representation of the priority grouping.

The priority can thus be set up as rotating for one group of channels and fixed for the other, or any other combination. While in Fixed Priority, the programmer can also specify which channel has the lowest priority.

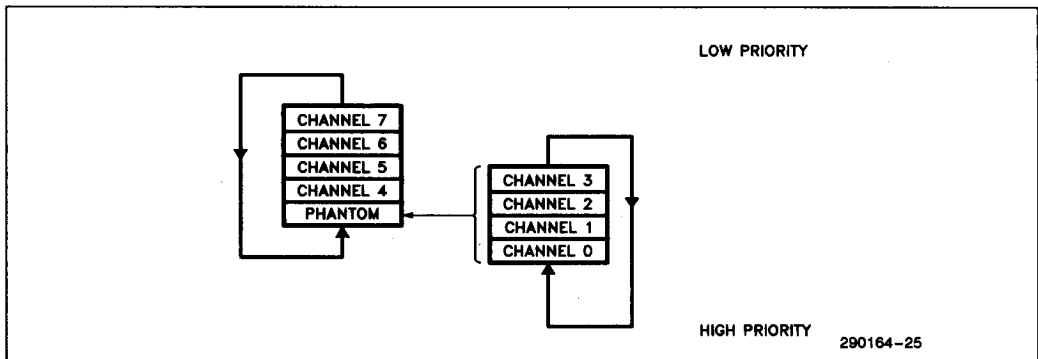

Figure 3-10. DMA Priority Grouping

The 82370 DMA Controller defaults to Fixed Priority. Channel 0 has the highest priority, then 1, 2, 3, 4, 5, 6, 7. Channel 7 has the lowest priority. Any time the DMA Controller arbitrates DMA requests, the requesting channel with the highest priority will be serviced next.

Fixed Priority can be entered into at any time by a software command. The priority levels in effect after the mode switch are determined by the current setting of the Programmable Priority.

Programmable Priority is available for fixing the priority of the DMA channels within a group to levels other than the default. Through a software command, the channel to have the lowest priority in a group can be specified. Each of the two groups of four channels can have the priority fixed in this way. The other channels in the group will follow the natural Fixed Priority sequence. This mode affects only the priority levels while operating with Fixed Priority.

For example, if channel 2 is programmed to have the lowest priority in its group, channel 3 has the highest priority. In descending order, the other channels would have the following priority: (3,0,1,2),4,5,6,7 (channel 2 lowest, channel 3 highest). If the upper

group were programmed to have channel 5 as the lowest priority channel, the priority would be (again, highest to lowest): 6,7, (3,0,1,2), 4,5. Figure 3-11 shows this example pictorially. The lower group is always prioritized as a fifth channel of the upper group (between channels 4 and 7).

The DMA Controller will only accept Programmable Priority commands while the addressed group is operating in Fixed Priority. Switching from Fixed to Rotating Priority preserves the current priority levels. Switching from Rotating to Fixed Priority returns the priority levels to those which were last programmed by use of Programmable Priority.

Rotating Priority allows the devices using DMA to share the system bus more evenly. An individual channel does not retain highest priority after being serviced, priority is passed to the next highest priority channel in the group. The channel which was most recently serviced inherits the lowest priority. This rotation occurs each time a channel is serviced. Figure 3-12 shows the sequence of events as priority is passed between channels. Note that the lower group rotates within the upper group, and that servicing a channel within the lower group causes rotation within the group as well as rotation of the upper group.

1

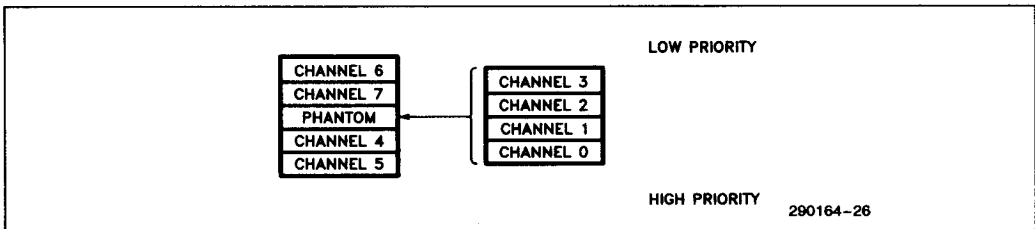

Figure 3-11. Example of Programmed Priority

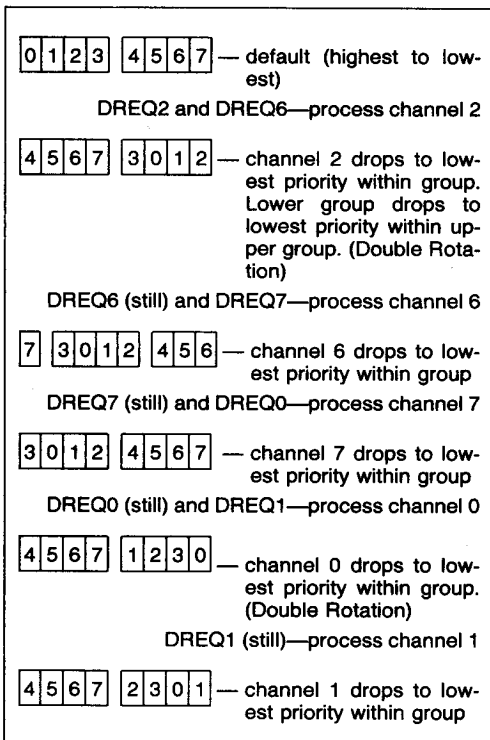

Figure 3-12. Rotating Channel Priority.
Lower and upper groups are programmed for the Rotating Priority Mode.

3.3.5 COMBINING PRIORITY MODES

Since the DMA Controller operates as two four-channel controllers in cascade, the overall priority scheme of all eight channels can take on a variety of forms. There are four possible combinations of priority modes between the two groups of channels: Fixed Priority only (default), Fixed Priority upper group/Rotating Priority lower group, Rotating Priority upper group/Fixed Priority lower group, and Rotating Priority only. Figure 3-13 illustrates the operation of the two combined priority methods.

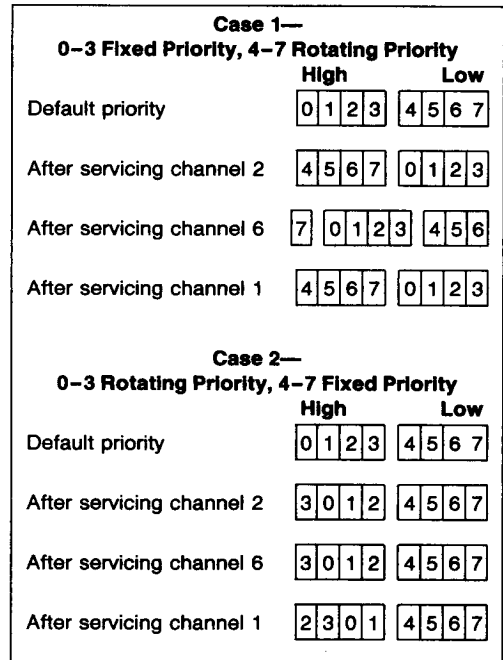

Figure 3-13. Combining Priority Modes

3.3.6 BUS OPERATION

Data may be transferred by the DMA Controller using two different bus cycle operations: Fly-By (one-cycle) and Two-Cycle. These bus handshake methods are selectable independently for each channel through a command register. Device data path widths are independently programmable for both Target and Requester. Also selectable through software is the direction of data transfer. All of these parameters affect the operation of the 82370 on a bus-cycle by bus-cycle basis.

3.3.6.1 Fly-By Transfers

The Fly-By Transfer Mode is the fastest and most efficient way to use the 82370 DMA Controller to transfer data. In this method of transfer, the data is written to the destination device at the same time it is read from the source. Only one bus cycle is used to accomplish the transfer.

In the Fly-By Mode, the DMA acknowledge signal is used to select the Requester. The DMA Controller simultaneously places the address of the Target on the address bus. The state of M/I/O# and W/R# during the Fly-By transfer cycle indicate the type of Target and whether the Target is being written to or read from. The Target's Bus Size is used as an incrementer for the Byte Count. The Requester address registers are ignored during Fly-By transfers.

Note that memory-to-memory transfers cannot be done using the Fly-By Mode. Only one memory of I/O address is generated by the DMA Controller at a time during Fly-By transfers. Only one of the devices being accessed can be selected by an address. Also, the Fly-By method of data transfer limits the hardware to accesses of devices with the same data bus width. The Temporary Registers are not affected in the Fly-By Mode.

Fly-By transfers also require that the data paths of the Target and Requester be directly connected. This requires that successive Fly-By access be to word boundaries, or that the Requester be capable of switching its connections to the data bus.

3.3.6.2 Two-Cycle Transfers

Two-Cycle transfers can also be performed by the 82370 DMA Controller. These transfers require at least two bus cycles to execute. The data being transferred is read into the DMA Controller's Temporary Register during the first bus cycle(s). The second bus cycle is used to write the data from the Temporary Register to the destination.

If the addresses of the data being transferred are not word aligned, the 82370 will recognize the situation and read and write the data in groups of bytes, placing them always at the proper destination. This process of collecting the desired bytes and putting them together is called "byte assembly". The reverse process (reading from aligned locations and writing to non-aligned locations) is called "byte disassembly".

The assembly/disassembly process takes place transparent to the software, but can only be done while using the Two-Cycle transfer method. The 82370 will always perform the assembly/disassembly process as necessary for the current data transfer. Any data path widths for either the Requester or Target can be used in the Two-Cycle Mode. This is very convenient for interfacing existing 8- and 16-bit peripherals to the 80376's 16-bit bus.

The 82370 DMA Controller always reads and write data within the word boundaries; i.e. if a word to be

read is crossing a word boundary, the DMA Controller will perform two read operations, each reading one byte, to read the 16-bit word into the Temporary Register. Also, the 82370 DMA Controller always attempts to fill the Temporary Register from the source before writing any data to the destination. If the process is terminated before the Temporary Register is filled (TC or EOP#), the 82370 will write the partial data to the destination. If a process is temporarily suspended (such as when DREQn is deactivated during a demand transfer), the contents of a partially filled Temporary Register will be stored within the 82370 until the process is restarted.

For example, if the source is specified as an 8-bit device and the destination as a 32-bit device, there will be four reads as necessary from the 8-bit source to fill the Temporary Register. Then the 82370 will write the 32-bit contents to the destination in two cycles of 16-bit each. This cycle will repeat until the process is terminated or suspended.

With Two-Cycle transfers, the devices that the 82370 accesses can reside at any address within I/O or memory space. The device must be able to decode the byte-enables (BLE#, BHE#). Also, if the device cannot accept data in byte quantities, the programmer must take care not to allow the DMA Controller to access the device on any address other than the device boundary.

3.3.6.3 Data Path Width and Data Transfer Rate Considerations

The number of bus cycles used to transfer a single "word" of data is affected by whether the Two-Cycle or the Fly-By (Single-Cycle) transfer method is used.

The number of bus cycles used to transfer data directly affects the data transfer rate. Inefficient use of bus cycles will decrease the effective data transfer rate that can be obtained. Generally, the data transfer rate is halved by using Two-Cycle transfers instead of Fly-By transfers.

The choice of data path widths of both Target and Requester affects the data transfer rate also. During each bus cycle, the largest pieces of data possible should be transferred.

The data path width of the devices to be accessed must be programmed into the DMA controller. The 82370 defaults after reset to 8-bit-to-8-bit data transfers, but the Target and Requester can have different data path widths, independent of each other and independent of the other channels. Since this is a software programmable function, more discussion of the uses of this feature are found in the section on programming.

3.3.6.4 Read, Write and Verify Cycles

Three different bus cycle types may be used in a data transfer. They are the Read, Write and Verify cycles. These cycle types dictate the way in which the 82370 operates on the data to be transferred.

A Read Cycle transfers data from the Target to the Requester. A Write Cycle transfers data from the Requester to the target. In a Fly-By transfer, the address and bus status signals indicate the access (read or write) to the Target; the access to the Requester is assumed to be the opposite.

The Verify Cycle is used to perform a data read only. No write access is indicated or assumed in a Verify Cycle. The Verify Cycle is useful for validating block fill operations. An external comparator must be provided to do any comparisons on the data read.

3.4 Bus Arbitration and Handshaking

Figure 3-14 shows the flow of events in the DMA request arbitration process. The arbitration sequence starts when the Requester asserts a DREQn (or DMA service is requested by software). Figure 3-15 shows the timing of the sequence of events following a DMA request. This sequence is executed for each channel that is activated. The DREQn signal can be replaced by a software DMA channel request with no change in the sequence.

After the Requester asserts the service request, the 82370 will request control of the bus via the HOLD signal. The 82370 will always assert the HOLD signal one bus state after the service request is asserted. The 80376 responds by asserting the HLDA signal, thus releasing control of the bus to the 82370 DMA Controller.

Priority of pending DMA service requests is arbitrated during the first state after HLDA is asserted by the 80376. The next state will be the beginning of the first transfer access of the highest priority process.

When the 82370 DMA Controller is finished with its current bus activity, it returns control of the bus to the host processor. This is done by driving the HOLD signal inactive. The 82370 does not drive any address or data bus signals after HOLD goes low. It enters the Slave Mode until another DMA process is requested. The processor acknowledges that it has

regained control of the bus by forcing the HLDA signal inactive. Note that the 82370's DMA Controller will not re-request control of the bus until the entire HOLD/HLDA handshake sequence is complete.

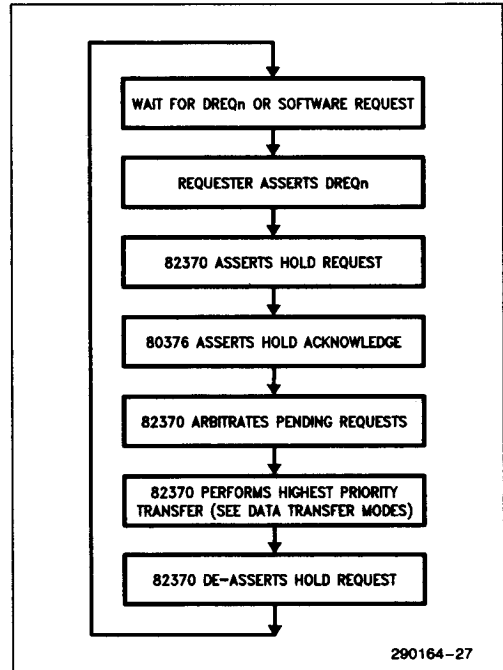

Figure 3-14. Bus Arbitration and DMA Sequence

The 82370 DMA Controller will terminate a current DMA process for one of three reasons: expired byte count, end-of-process command (EOP# activated) from a peripheral, or deactivated DMA request signal. In each case, the controller will de-assert HOLD immediately after completing the data transfer in progress. These three methods of process termination are illustrated in Figures 3-16, 3-19 and 3-18, respectively.

An expired byte count indicates that the current process is complete as programmed and the channel has no further transfers to process. The channel must be restarted according to the currently programmed Buffer Transfer Mode, or reprogrammed completely, including a new Buffer Transfer Mode.

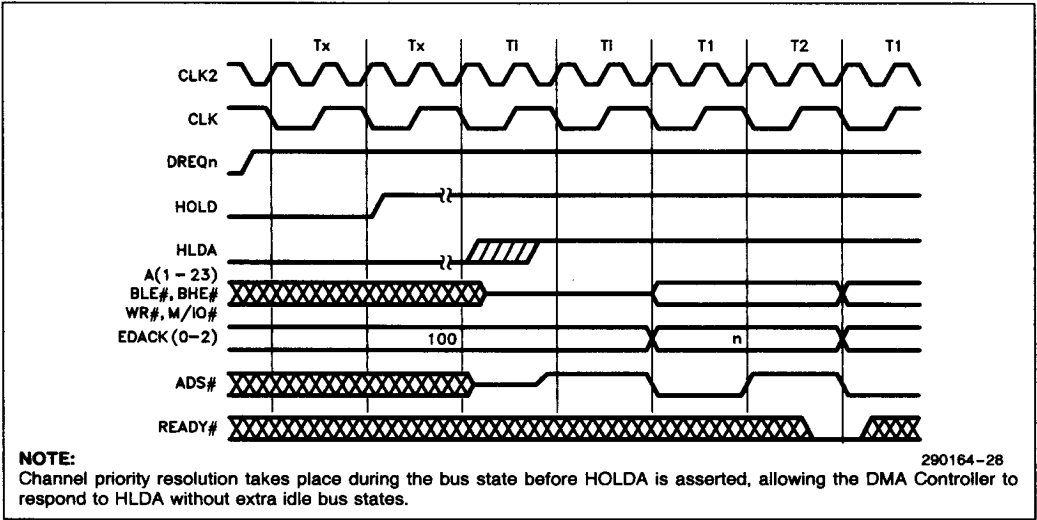

Figure 3-15. Beginning of a DMA process

If the peripheral activates the EOP# signal, it is indicating that it will not accept or deliver any more data for the current buffer. The 82370 DMA Controller considers this as a completion of the channel's current process and interprets the condition the same way as if the byte count expired.

The action taken by the 82370 DMA Controller in response to a de-activated DREQn signal depends on the Data Transfer Mode of the channel. In the Demand Mode, data transfers will take place as long as the DREQn is active and the byte count has not expired. In the Block Mode, the controller will complete the entire block transfer without relinquishing the bus, even if DREQn goes inactive before the

transfer is complete. In the Single Mode, the controller will execute single data transfers, relinquishing the bus between each transfer, as long as DREQn is active.

Normal termination of a DMA process due to expiration of the byte count (Terminal Count—TC) is shown in Figure 3-16. The condition of DREQn is ignored until after the process is terminated. If the channel is programmed to auto-initialize, HOLD will be held active for an additional seven clock cycles while the auto-initialization takes place.

Table 3-3 shows the DMA channel activity due to EOP# or Byte Count expiring (Terminal Count).

Table 3-3. DMA Channel Activity Due to Terminal Count or External EOP#

| Buffer Process | Single or Chaining-Base Empty | | Auto-Initialize | | Chaining-Base Loaded | |
|-----------------------|-------------------------------|-----|-----------------|------|----------------------|------|
| | True | X | True | X | True | X |
| EVENT | | | | | | |
| Terminal Count | True | X | True | X | True | X |
| EOP# | X | 0 | X | 0 | X | 0 |
| RESULTS | | | | | | |
| Current Registers | Set | Set | Load | Load | Load | Load |
| Channel Mask | Set | Set | Load | Load | Load | Load |
| EOP# Output | 0 | X | 0 | X | 1 | X |
| Terminal Count Status | Set | Set | Set | Set | 1 | X |
| Software Request | CLR | CLR | CLR | CLR | 1 | X |

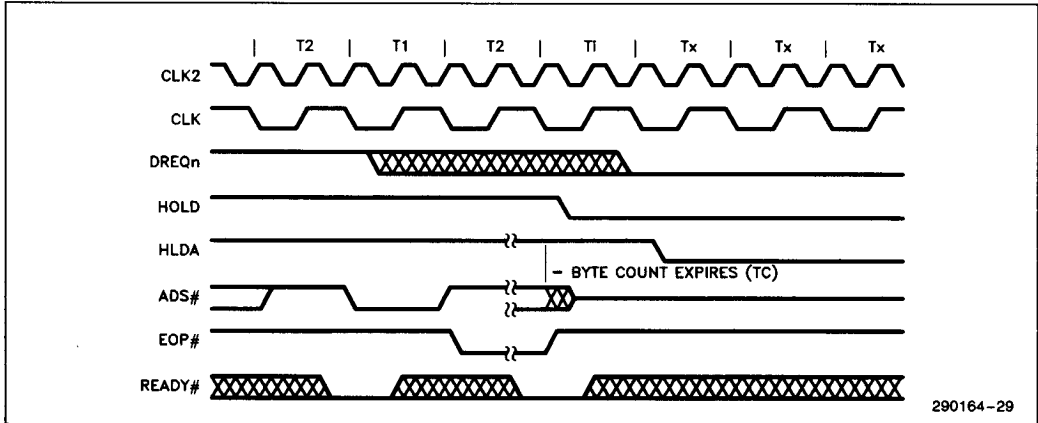

Figure 3-16. Termination of a DMA Process Due to Expiration of Current Byte Count

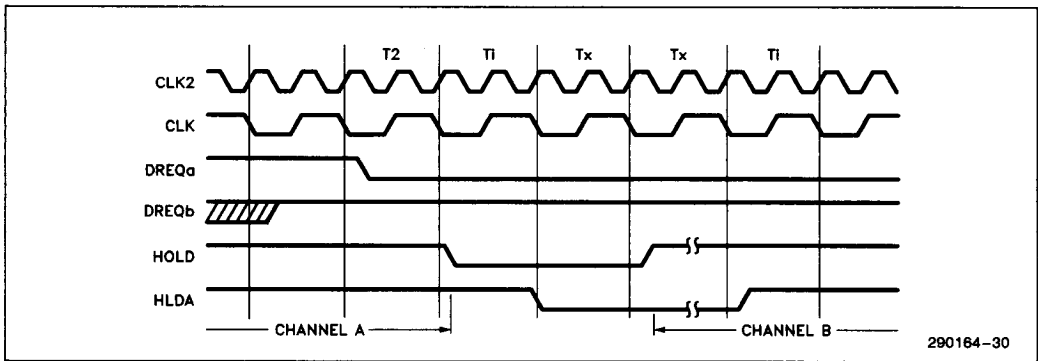

Figure 3-17. Switching between Active DMA Channels

The 82370 always relinquishes control of the bus between channel services. This allows the hardware designer the flexibility to externally arbitrate bus hold requests, if desired. If another DMA request is pending when a higher priority channel service is completed, the 82370 will relinquish the bus until the hold acknowledge is inactive. One bus state after the HLDA signal goes inactive, the 82370 will assert HOLD again. This is illustrated in Figure 3-17.

3.4.1 SYNCHRONOUS AND ASYNCHRONOUS SAMPLING OF DREQn AND EOP#

As an indicator that a DMA service is to be started, DREQn is always sampled asynchronous. It is sam-

pled at the beginning of a bus state and acted upon at the end of the state. Figure 3-15 illustrates the start of a DMA process due to a DREQn input.

The DREQn and EOP# inputs can be programmed to be sampled either synchronously or asynchronously to signal the end of a transfer.

The synchronous mode affords the Requester one bus state of extra time to react to an access. This means the Requester can terminate a process on the current access, without losing any data. The asynchronous mode requires that the input signal be presented prior to the beginning of the last state of the Requester access.



The timing relationships of the DREQn and EOP# signals to the termination of a DMA transfer are shown in Figures 3-18 and 3-19. Figure 3-18 shows the termination of a DMA transfer due to inactive DREQn. Figure 3-19 shows the termination of a DMA process due to an active EOP# input.

In the Synchronous Mode, DREQn and EOP# are sampled at the end of the last state of every Requester data transfer cycle. If EOP# is active or DREQn is inactive at this time, the 82370 recognizes this access to the Requester as the last transfer. At this point, the 82370 completes the transfer in progress, if necessary, and returns bus control to the host.

In the asynchronous mode, the inputs are sampled at the beginning of every state of a Requester access. The 82370 waits until the end of the state to act on the input.

DREQn and EOP# are sampled at the latest possible time when the 82370 can determine if another transfer is required. In the Synchronous Mode, DREQn and EOP# are sampled on the trailing edge of the last bus state before another data access cycle begins. The Asynchronous Mode requires that the signals be valid one clock cycle earlier.

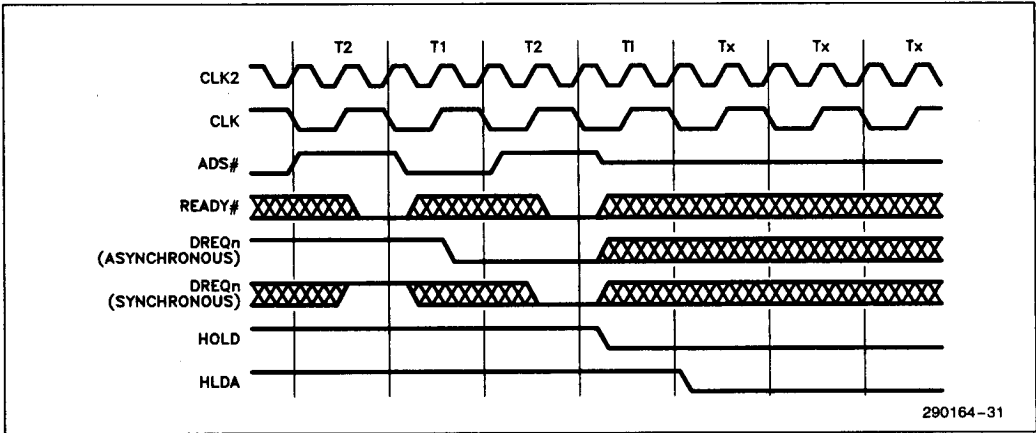

Figure 3-18. Termination of a DMA Process due to De-Asserting DREQn

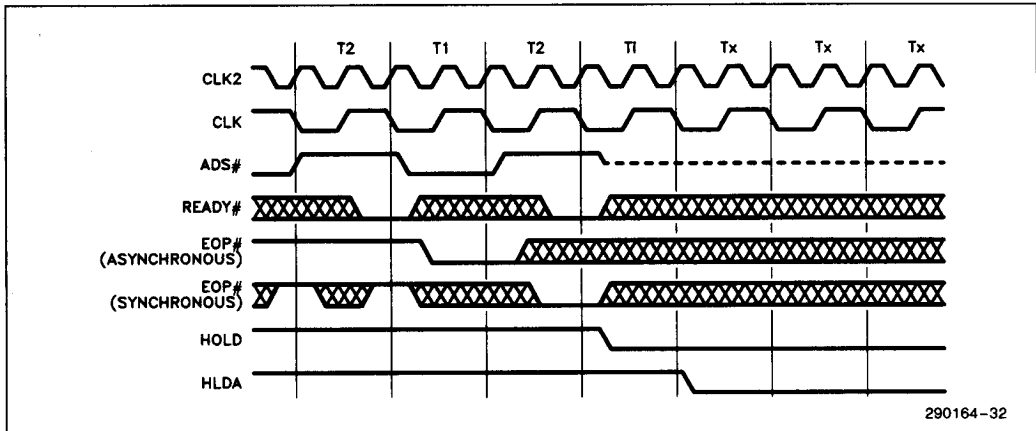

Figure 3-19. Termination of a DMA Process due to an External EOP#

While in the Pipeline Mode, if the NA# signal is sampled active during a transfer, the end of the state where NA# was sampled active is when the 82370 decides whether to commit to another transfer. The device must de-assert DREQn or assert EOP# before NA# is asserted, otherwise the 82370 will commit to another, possibly undesired, transfer.

Synchronous DREQn and EOP# sampling allows the peripheral to prevent the next transfer from occurring by de-activating DREQn or asserting EOP# during the current Requester access, before the 82370 DMA Controller commits itself to another transfer. The DMA Controller will not perform the next transfer if it has not already begun the bus cycle. Asynchronous sampling allows less stringent timing requirements than the Synchronous Mode, but requires that the DREQn signal be valid at the beginning of the next to last bus state of the current Requester access.

Using the Asynchronous Mode with zero wait states can be very difficult. Since the addresses and control signals are driven by the 82370 near half-way through the first bus state of a transfer, and the Asynchronous Mode requires that DREQn be inactive before the end of the state, the peripheral being accessed is required to present DREQn only a few nanoseconds after the control information is available. This means that the peripheral's control logic must be extremely fast (practically non-causal). An alternative is the Synchronous Mode.

3.4.2 ARBITRATION OF CASCADED MASTER REQUESTS

The Cascade Mode allows another DMA-type device to share the bus by arbitrating its bus accesses with the 82370's. Seven of the eight DMA channels (0-3 and 5-7) can be connected to a cascaded device. The cascaded device requests bus control through the DREQn line of the channel which is programmed to operate in Cascade Mode. Bus hold acknowledgment is signalled to the cascaded device through the EDACK lines. When the EDACK lines are active with the code for the requested cascade channel, the bus is available to the cascaded master device.

A cascade cycle begins the same way a regular DMA cycle begins. The requesting bus master asserts the DREQn line on the 82370. This bus control request is arbitrated as any other DMA request would be. If any channel receives a DMA request, the 82370 requests control of the bus. When the host acknowledges that it has released bus control, the 82370 acknowledges to the requesting master that it may access the bus. The 82370 enters an idle state until the new master relinquishes control.

A cascade cycle will be terminated by one of two events: DREQn going inactive, or HLDA going inactive. The normal way to terminate the cascade cycle

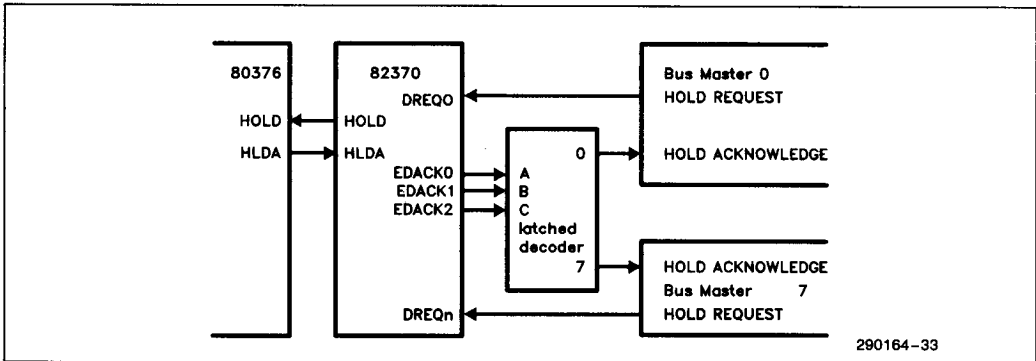

Figure 3-20. Cascaded Bus Master

is for the cascaded master to drop the DREQn signal. Figure 3-21 shows the two cascade cycle termination sequences.

The Refresh Controller may interrupt the cascaded master to perform a refresh cycle. If this occurs, the 82370 DMA Controller will de-assert the EDACK signal (hold acknowledge to cascaded master) and wait for the cascaded master to remove its hold request. When the 82370 regains bus control, it will perform the refresh cycle in its normal fashion. After the refresh cycle has been completed, and if the cascaded device has re-asserted its request, the 82370 will return control to the cascaded master which was interrupted.

The 82370 assumes that it is the only device monitoring the HLDA signal. If the system designer wishes to place other devices on the bus as bus masters, the HLDA from the processor must be intercepted before presenting it to the 82370. Using the Cascade capability of the 82370 DMA Controller offers a much better solution.

3.4.3 ARBITRATION OF REFRESH REQUESTS

The arbitration of refresh requests by the DRAM Refresh Controller is slightly different from normal DMA

channel request arbitration. The 82370 DRAM Refresh Controller always has the highest priority of any DMA process. It also can interrupt a process in progress. Two types of processes in progress may be encountered: normal DMA, and bus master cascade.

In the event of a refresh request during a normal DMA process, the DMA Controller will complete the data transfer in progress and then execute the refresh cycle before continuing with the current DMA process. The priority of the interrupted process is not lost. If the data transfer cycle interrupted by the Refresh Controller is the last of a DMA process, the refresh cycle will always be executed before control of the bus is transferred back to the host.

When the Refresh Controller request occurs during a cascade cycle, the Refresh Controller must be assured that the cascaded master device has relinquished control of the bus before it can execute the refresh cycle. To do this, the DMA Controller drops the EDACK signal to the cascaded master and waits for the corresponding DREQn input to go inactive. By dropping the DREQn signal, the cascaded master relinquishes the bus. The Refresh Controller then performs the refresh cycle. Control of the bus is returned to the cascaded master if DREQn returns to an active state before the end of the refresh cycle, otherwise control is passed to the processor and the cascaded master loses its priority.

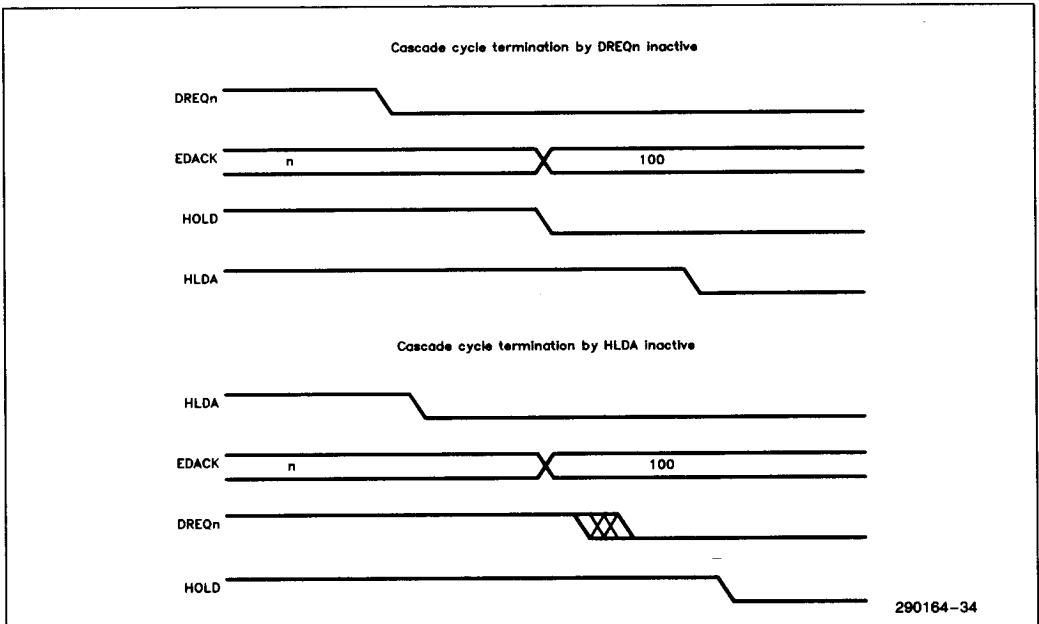

Figure 3-21. Cascade Cycle Termination

3.5 DMA Controller Register Overview

The 82370 DMA Controller contains 44 registers which are accessible to the host processor. Twenty-four of these registers contain the device addresses and data counts for the individual DMA channels (three per channel). The remaining registers are control and status registers for initiating and monitoring the operation of the 82370 DMA Controller. Table 3-4 lists the DMA Controller's registers and their accessibility.

Table 3-4. DMA Controller Registers

| Register Name | Access |
|--|------------|
| Control/Status Registers—one each per group | |
| Command Register I | write only |
| Command Register II | write only |
| Mode Register I | write only |
| Mode Register II | write only |
| Software Request Register | read/write |
| Mask Set-Reset Register | write only |
| Mask Read-Write Register | read/write |
| Status Register | read only |
| Bus Size Register | write only |
| Chaining Register | read/write |
| Channel Registers—one each per channel | |
| Base Target Address | write only |
| Current Target Address | read only |
| Base Requester Address | write only |
| Current Requester Address | read only |
| Base Byte Count | write only |
| Current Byte Count | read only |

3.5.1 CONTROL/STATUS REGISTERS

The following registers are available to the host processor for programming the 82370 DMA Controller into its various modes and for checking the operating status of the DMA processes. Each set of four DMA channels has one of each of these registers associated with it.

Command Register I

Enables or disables the DMA channel as a group. Sets the Priority Mode (Fixed or Rotating) of the group. This write-only register is cleared by a hardware reset, defaulting to all channels enabled and Fixed Priority Mode.

Command Register II

Sets the sampling mode of the DREQn and EOP# inputs. Also sets the lowest priority channel for the group in the Fixed Priority Mode. The functions programmed through Command Register II default after

a hardware reset to: asynchronous DREQn and EOP#, and channels 3 and 7 lowest priority.

Mode Registers I

Mode Register I is identical in function to the Mode register of the 8237A. It programs the following functions for an individually selected channel:

Type of Transfer—read, write, verify
 Auto-Initialize—enable or disable
 Target Address Count—increment or decrement
 Data Transfer Mode—demand, single, block, cascade

Mode Register I functions default to the following after reset: verify transfer, Auto-Initialize disabled, increment Target address, Demand Mode.

Mode Register II

Programs the following functions for an individually selected channel:

Target Address Hold—enable or disable
 Requester Address Count—increment or decrement
 Requester Address Hold—enable or disable
 Target Device Type—I/O or Memory
 Requester Device Type—I/O or Memory
 Transfer Cycles—Two-Cycle or Fly-By

Mode Register II functions are defined as follows after a hardware reset: Disable Target Address Hold, Increment Requester Address, Target (and Requester) in memory, Fly-By Transfer Cycles. Note: Requester Device Type ignored in Fly-By Transfers.

Software Request Register

The DMA Controller can respond to service requests which are initiated by software. Each channel has an internal request status bit associated with it. The host processor can write to this register to set or reset the request bit of a selected channel.

The status of a group's software DMA service requests can be read from this register as well. Each status bit is cleared upon Terminal Count or external EOP#.

The software DMA requests are non-maskable and subject to priority arbitration with all other software and hardware requests. The entire register is cleared by a hardware reset.

Mask Registers

Each channel has associated with it a mask bit which can be set/reset to disable/enable that channel. Two methods are available for setting and clearing the mask bits. The Mask Set/Reset Register is a

write-only register which allows the host to select an individual channel and either set or reset the mask bit for that channel only. The Mask Read/Write Register is available for reading the mask bit status and for writing mask bits in groups of four.

The mask bits of a group may be cleared in one step by executing the Clear Mask Command. See the DMA Programming section for details. A hardware reset sets all of the channel mask bits, disabling all channels.

Status Register

The Status register is a read-only register which contains the Terminal Count (TC) and Service Request status for a group. Four bits indicate the TC status and four bits indicate the hardware request status for the four channels in the group. The TC bits are set when the Byte Count expires, or when and external EOP# is asserted. These bits are cleared by reading from the Status Register. The Service Request bit for a channel indicates when there is a hardware DMA request (DREQn) asserted for that channel. When the request has been removed, the bit is cleared.

Bus Size Register

This write-only register is used to define the bus size of the Target and Requester of a selected channel. The bus sizes programmed will be used to dictate the sizes of the data paths accessed when the DMA channel is active. The values programmed into this register affect the operation of the Temporary Register. When 32-bit bus width is programmed, the 82370 DMA Controller will access the device twice through its 16-bit external Data Bus to perform a 32-bit data transfer. Any byte-assembly required to make the transfers using the specified data path widths will be done in the Temporary Register. The Bus Size register of the Target is used as an increment/decrement value for the Byte Counter and Target Address when in the Fly-By Mode. Upon reset, all channels default to 8-bit Targets and 8-bit Requesters.

Chaining Register

As a command or write register, the Chaining register is used to enable or disable the Chaining Mode for a selected channel. Chaining can either be disabled or enabled for an individual channel, independently of the Chaining Mode status of other channels. After a hardware reset, all channels default to Chaining disabled.

When read by the host, the Chaining Register provides the status of the Chaining Interrupt of each of the channels. These interrupt status bits are cleared when the new buffer information has been loaded.

3.5.2 CHANNEL REGISTERS

Each channel has three individually programmable registers necessary for the DMA process; they are the Base Byte Count, Base Target Address, and Base Requester Address registers. The 24-bit Base Byte Count register contains the number of bytes to be transferred by the channel. The 24-bit Base Target Address Register contains the beginning address (memory or I/O) of the Target device. The 24-bit Base Requester Address register contains the base address (memory or I/O) of the device which is to request DMA service.

Three more registers for each DMA channel exist within the DMA Controller which are directly related to the registers mentioned above. These registers contain the current status of the DMA process. They are the Current Byte Count register, the Current Target Address, and the Current Requester Address. It is these registers which are manipulated (incremented, decremented, or held constant) by the 82370 DMA Controller during the DMA process. The Current registers are loaded from the Base registers at the beginning of a DMA process.

The Base registers are loaded when the host processor writes to the respective channel register addresses. Depending on the mode in which the channel is operating, the Current registers are typically loaded in the same operation. Reading from the channel register addresses yields the contents of the corresponding Current register.

To maintain compatibility with software which accesses an 8237A, a Byte Pointer Flip-Flop is used to control access to the upper and lower bytes of some words of the Channel Registers. These words are accessed as byte pairs at single port addresses. The Byte Pointer Flip-Flop acts as a one-bit pointer which is toggled each time a qualifying Channel Register byte is accessed.

It always points to the next logical byte to be accessed of a pair of bytes.

The Channel registers are arranged as pairs of words, each pair with its own port address. Addressing the port with the Byte Pointer Flip-Flop reset accesses the least significant byte of the pair. The most significant byte is accessed when the Byte Pointer is set.

For compatibility with existing 8237A designs, there is one exception to the above statements about the Byte Pointer Flip-Flop. The third byte (bits 16-23) of the Target Address is accessed through its own port address. The Byte Pointer Flip-Flop is not affected by any accesses to this byte.

The upper eight bits of the Byte Count Register are cleared when the least significant byte of the register is loaded. This provides compatibility with software which accesses an 8237A. The 8237A has 16-bit Byte Count Registers.

NOTE:

The 82370 is a subset of the Intel 82380 32-bit DMA Controller with Integrated System Peripherals.

Although the 82370 has 24 address bits externally, the programming model is actually a full 32 bits wide. For this reason, there are some "hidden" DMA registers in the 82370 register set. These hidden registers correspond to what would be A24–A31 in a 32-bit system.

Think of the 82370 addresses as though they were 32 bits wide, with only the lower 24 bits available externally.

This should be of concern in two areas:

1. Understanding the Byte Pointer Flip Flop
2. Removing the IRQ1 Chaining Interrupt

The byte pointer flip flop will behave as though the hidden upper address bits were accessible.

The IRQ1 Chaining Interrupt will be removed only when the hidden upper address bits are programmed. You will note that since the hidden upper address bits are not available externally, the value you program into the registers is not important. The act of programming the hidden register is critical in removing the IRQ1 Chaining interrupt for a DMA channel.

The port assignments for these hidden upper address bits come directly from the port assignments of the Intel 82380. For your convenience, those port definitions have been included in this data sheet in section 3.7.

3.5.3 TEMPORARY REGISTERS

Each channel has a 32-bit Temporary Register used for temporary data storage during two-cycle DMA transfers. It is this register in which any necessary byte assembly and disassembly of non-aligned data is performed. Figure 3-22 shows how a block of data will be moved between memory locations with different boundaries. Note that the order of the data does not change.

If the destination is the Requester and an early process termination has been indicated by the EOP# signal or DREQn inactive in the Demand Mode, the Temporary Register is not affected. If data remains in the Temporary Register due to differences in data path widths of the Target and Requester, it will not

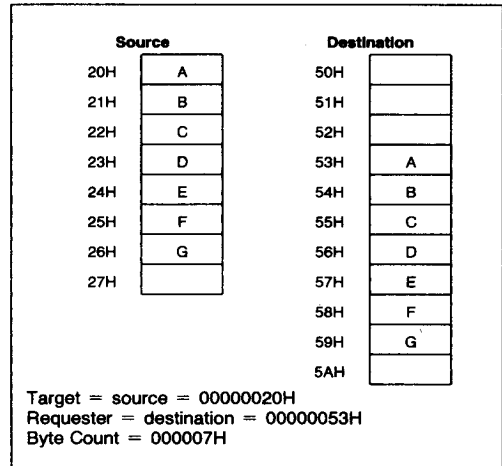

Figure 3-22. Transfer of data between memory locations with different boundaries. This will be the result, independent of data path width.

be transferred or otherwise lost, but will be stored for later transfer.

If the destination is the Target and the EOP# signal is sensed active during the Requester access of a transfer, the DMA Controller will complete the transfer by sending to the Target whatever information is in the Temporary Register at the time of process termination. This implies that the Target could be accessed with partial data in two accesses. For this reason it is advisable to have an I/O device designated as a Requester, unless it is capable of handling partial data transfers.

3.6 DMA Controller Programming

Programming a DMA Channel to perform a needed DMA function is in general a four step process. First the global attributes of the DMA Controller are programmed via the two Command Registers. These global attributes include: priority levels, channel group enables, priority mode, and DREQn/EOP# input sampling.

The second step involves setting the operating modes of the particular channel. The Mode Registers are used to define the type of transfer and the handshaking modes. The Bus Size Register and Chaining Register may also need to be programmed in this step.

The third step in setting up the channel is to load the Base Registers in accordance with the needs of the operating modes chosen in step two. The Current Registers are automatically loaded from the Base Registers, if required by the Buffer Transfer Mode in

effect. The information loaded and the order in which it is loaded depends on the operating mode. A channel used for cascading, for example, needs no buffer information and this step can be skipped entirely.

The last step is to enable the newly programmed channel using one of the Mask Registers. The channel is then available to perform the desired data transfer. The status of the channel can be observed at any time through the Status Register, Mask Register, Chaining Register, and Software Request register.

Once the channel is programmed and enabled, the DMA process may be initiated in one of two ways, either by a hardware DMA request (DREQn) or a software request (Software Request Register).

Once programmed to a particular Process/Mode configuration, the channel will operate in that configuration until programmed otherwise. For this reason, restarting a channel after the current buffer expires does not require complete reprogramming of the channel. Only those parameters which have changed need to be reprogrammed. The Byte Count Register is always changed and must be reprogrammed. A Target or Requester Address Register which is incremented or decremented should be reprogrammed also.

3.6.1 BUFFER PROCESSES

The Buffer Process is determined by the Auto-Initialize bit of Mode Register I and the Chaining Register. If Auto-Initialize is enabled, Chaining should not be used.

3.6.1.1 Single Buffer Process

The Single Buffer Process is programmed by disabling Chaining via the Chaining Register and programming Mode Register I for non-Auto-Initialize.

3.6.1.2 Buffer Auto-Initialize Process

Setting the Auto-Initialize bit in Mode Register I is all that is necessary to place the channel in this mode. Buffer Auto-Initialize must not be enabled simultaneous to enabling the Buffer Chaining Mode as this will have unpredictable results.

Once the Base Registers are loaded, the channel is ready to be enabled. The channel will reload its Current Registers from the Base Registers each time the Current Buffer expires, either by an expired Byte Count or an external EOP#.

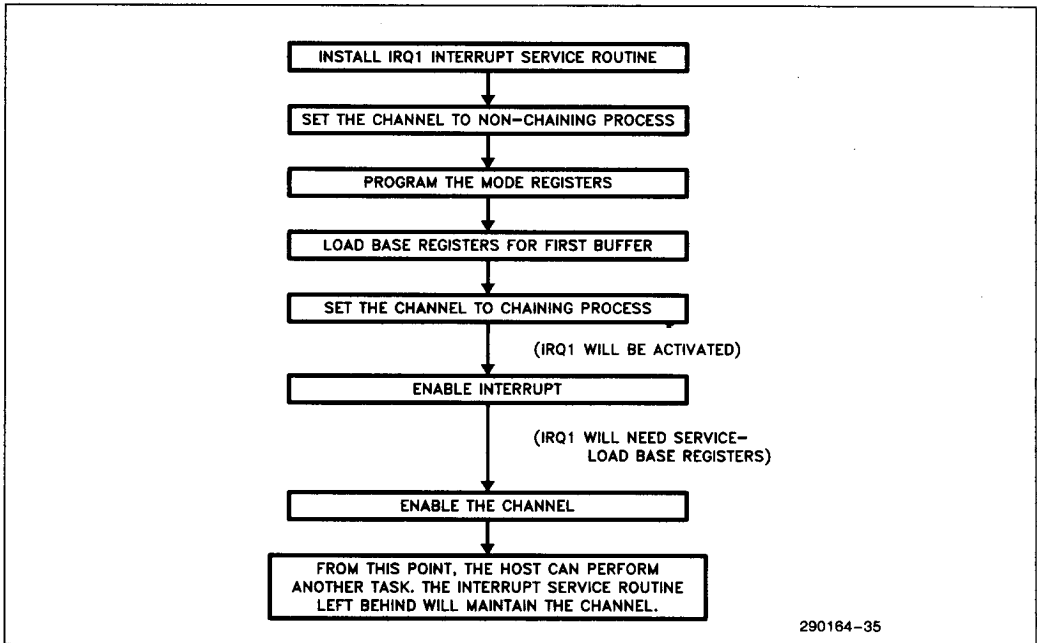

Figure 3-23. Flow of Events in the Buffer Chaining Process

290164-35

3.6.1.3 Buffer Chaining Process

The Buffer Chaining Process is entered into from the Single Buffer Process. The Mode Registers should be programmed first, with all of the Transfer Modes defined as if the channel were to operate in the Single Buffer Process. The channel's Base Registers are then loaded. When the channel has been set up in this way, and the chaining interrupt service routine is in place, the Chaining Process can be entered by programming the Chaining Register. Figure 3-23 illustrates the Buffer Chaining Process.

An interrupt (IRQ1) will be generated immediately after the Chaining Process is entered, as the channel then perceives the Base Registers as empty and in need of reloading. It is important to have the interrupt service routine in place at the time the Chaining Process is entered into. The interrupt request is removed when the most significant byte of the Base Target Address is loaded.

The interrupt will occur again when the first buffer expires and the Current Registers are loaded from the Base Registers. The cycle continues until the Chaining Process is disabled, or the host fails to respond to IRQ1 before the Current Buffer expires.

Exiting the Chaining Process can be done by resetting the Chaining Mode Register. If an interrupt is pending for the channel when the Chaining Register is reset, the interrupt request will be removed. The Chaining Process can be temporarily disabled by setting the channel's Mask bit in the Mask Register.

The interrupt service routine for IRQ1 has the responsibility of reloading the Base Registers as necessary. It should check the status of the channel to determine the cause of channel expiration, etc. It should also have access to operating system information regarding the channel, if any exists. The IRQ1 service routine should be capable of determining whether the chain should be continued or terminated and act on that information.

3.6.2 DATA TRANSFER MODES

The Data Transfer Modes are selected via Mode Register I. The Demand, Single, and Block Modes are selected by bits D6 and D7. The individual transfer type (Fly-By vs Two-Cycle, Read-Write-Verify, and I/O vs Memory) is programmed through both of the Mode registers.

3.6.3 CASCADED BUS MASTERS

The Cascade Mode is set by writing ones to D7 and D6 of Mode Register I. When a channel is pro-

grammed to operate in the Cascade Mode, all of the other modes associated with Mode Registers I and II are ignored. The priority and DREQn/EOP# definitions of the Command Registers will have the same effect on the channel's operation as any other mode.

3.6.4 SOFTWARE COMMANDS

There are five port addresses which, when written to, command certain operations to be performed by the 82370 DMA Controller. The data written to these locations is not of consequence, writing to the location is all that is necessary to command the 82370 to perform the indicated function. Following are descriptions of the command functions.

Clear Byte Pointer Flip-Flop—Location 000CH

Resets the Byte Pointer Flip-Flop. This command should be performed at the beginning of any access to the channel registers in order to be assured of beginning at a predictable place in the register programming sequence.

Master Clear—Location 000DH

All DMA functions are set to their default states. This command is the equivalent of a hardware reset to the DMA Controller. Functions other than those in the DMA Controller section of the 82370 are not affected by this command.

Clear Mask Register—Channels 0–3
 — Location 000EH
 Channels 4–7
 — Location 00CEH

This command simultaneously clears the Mask Bits of all channels in the addressed group, enabling all of the channels in the group.

Clear TC Interrupt Request—Location 001EH

This command resets the Terminal Count Interrupt Request Flip-Flop. It is provided to allow the program which made a software DMA request to acknowledge that it has responded to the expiration of the requested channel(s).

3.7 Register Definitions

The following diagrams outline the bit definitions and functions of the 82370 DMA Controller's Status and Control Registers. The function and programming of the registers is covered in the previous section on DMA Controller Programming. An entry of "X" as a bit value indicates "don't care."

Channel Registers (read Current, write Base)

| Channel | Register Name | Address (hex) | Byte Pointer | Bits Accessed |
|-----------|-------------------|---------------|--------------|---------------|
| Channel 0 | Target Address | 00 | 0 | 0-7 |
| | | | 1 | 8-15 |
| | | 87 | x | 16-23 |
| | Byte Count | 10 | 0 | 24-31(*) |
| | | 01 | 0 | 0-7 |
| | | | 1 | 8-15 |
| | Requester Address | 11 | 0 | 16-23 |
| | | 90 | 0 | 0-7 |
| | | | 1 | 8-15 |
| | | 91 | 0 | 16-23 |
| | | | 1 | 24-31(*) |
| Channel 1 | Target Address | 02 | 0 | 0-7 |
| | | | 1 | 8-15 |
| | | 83 | x | 16-23 |
| | Byte Count | 12 | 0 | 24-31(*) |
| | | 03 | 0 | 0-7 |
| | | | 1 | 8-15 |
| | Requester Address | 13 | 0 | 16-23 |
| | | 92 | 0 | 0-7 |
| | | | 1 | 8-15 |
| | | 93 | 0 | 16-23 |
| | | | 1 | 24-31(*) |
| Channel 2 | Target Address | 04 | 0 | 0-7 |
| | | | 1 | 8-15 |
| | | 81 | x | 16-23 |
| | Byte Count | 14 | 0 | 24-31(*) |
| | | 05 | 0 | 0-7 |
| | | | 1 | 8-15 |
| | Requester Address | 15 | 0 | 16-23 |
| | | 94 | 0 | 0-7 |
| | | | 1 | 8-15 |
| | | 95 | 0 | 16-23 |
| | | | 1 | 24-31(*) |
| Channel 3 | Target Address | 06 | 0 | 0-7 |
| | | | 1 | 8-15 |
| | | 82 | x | 16-23 |
| | Byte Count | 16 | 0 | 24-31(*) |
| | | 07 | 0 | 0-7 |
| | | | 1 | 8-15 |
| | Requester Address | 17 | 0 | 16-23 |
| | | 96 | 0 | 0-7 |
| | | | 1 | 8-15 |
| | | 97 | 0 | 16-23 |
| | | | 1 | 24-31(*) |

1

Channel Registers (read Current, write Base) (Continued)

| Channel | Register Name | Address (hex) | Byte Pointer | Bits Accessed |
|-----------|-------------------|---------------|--------------|---------------|
| Channel 4 | Target Address | C0 | 0 | 0-7 |
| | | | 1 | 8-15 |
| | | 8F | x | 16-23 |
| | Byte Count | D0 | 0 | 24-31(*) |
| | | C1 | 0 | 0-7 |
| | | | 1 | 8-15 |
| | Requester Address | D1 | 0 | 16-23 |
| | | 98 | 0 | 0-7 |
| | | | 1 | 8-15 |
| | | 99 | 0 | 16-23 |
| | | | 1 | 24-31(*) |
| Channel 5 | Target Address | C2 | 0 | 0-7 |
| | | | 1 | 8-15 |
| | | 8B | x | 16-23 |
| | Byte Count | D2 | 0 | 24-31(*) |
| | | C3 | 0 | 0-7 |
| | | | 1 | 8-15 |
| | Requester Address | D3 | 0 | 16-23 |
| | | 9A | 0 | 0-7 |
| | | | 1 | 8-15 |
| | | 9B | 0 | 16-23 |
| | | | 1 | 24-31(*) |
| Channel 6 | Target Address | C4 | 0 | 0-7 |
| | | | 1 | 8-15 |
| | | 89 | x | 16-23 |
| | Byte Count | D4 | 0 | 24-31(*) |
| | | C5 | 0 | 0-7 |
| | | | 1 | 8-15 |
| | Requester Address | D5 | 0 | 16-23 |
| | | 9C | 0 | 0-7 |
| | | | 1 | 8-15 |
| | | 9D | 0 | 16-23 |
| | | | 1 | 24-31(*) |
| Channel 7 | Target Address | C6 | 0 | 0-7 |
| | | | 1 | 8-15 |
| | | 8A | x | 16-23 |
| | Byte Count | D6 | 0 | 24-31(*) |
| | | C7 | 0 | 0-7 |
| | | | 1 | 8-15 |
| | Requester Address | D7 | 0 | 16-23 |
| | | 9E | 0 | 0-7 |
| | | | 1 | 8-15 |
| | | 9F | 0 | 16-23 |
| | | | 1 | 24-31(*) |

NOTE:

(*)These bits are not available externally. You need to be aware of their existence for chaining and Byte Pointer Flip-Flop operations. Please see section 3.5.2 for further details.

Command Register I (write only)

Port Addresses— Channels 0–3—0008H
Channels 4–7—00C8H

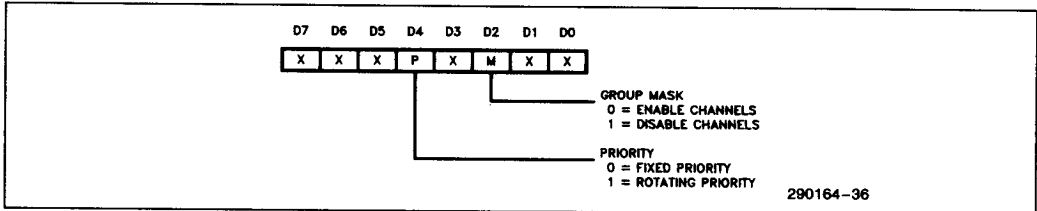

1

Command Register II (write only)

Port Addresses— Channels 0–3—001AH
Channels 4–7—00DAH

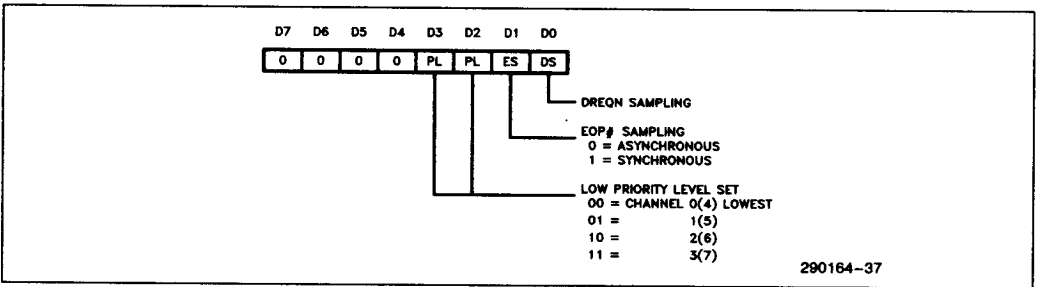

Mode Register I (write only)

Port Addresses— Channels 0–3—000BH
Channels 4–7—00CBH

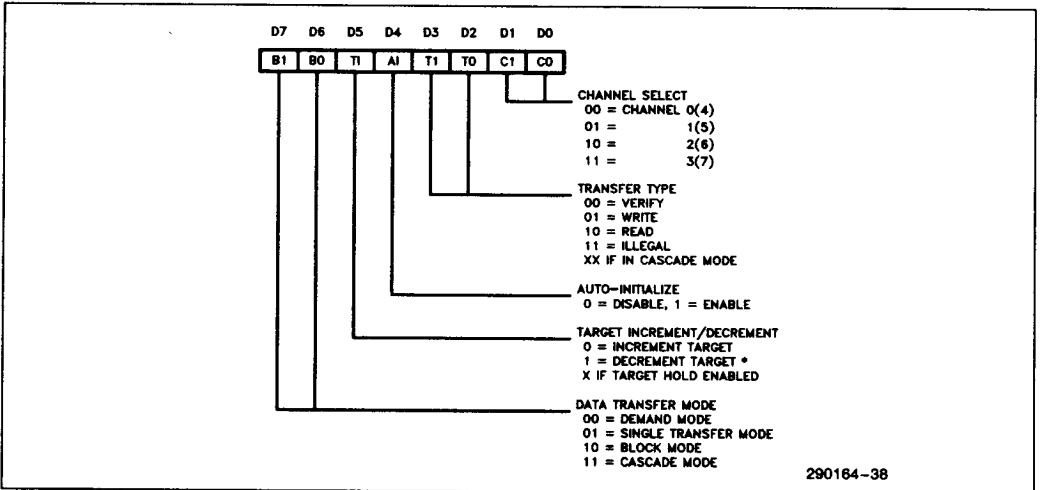

*Target and Requester DECREMENT is allowed only for byte transfers.

Mode Register II (write only)

Port Addresses— Channels 0–3—001BH
 Channels 4–7—00DBH

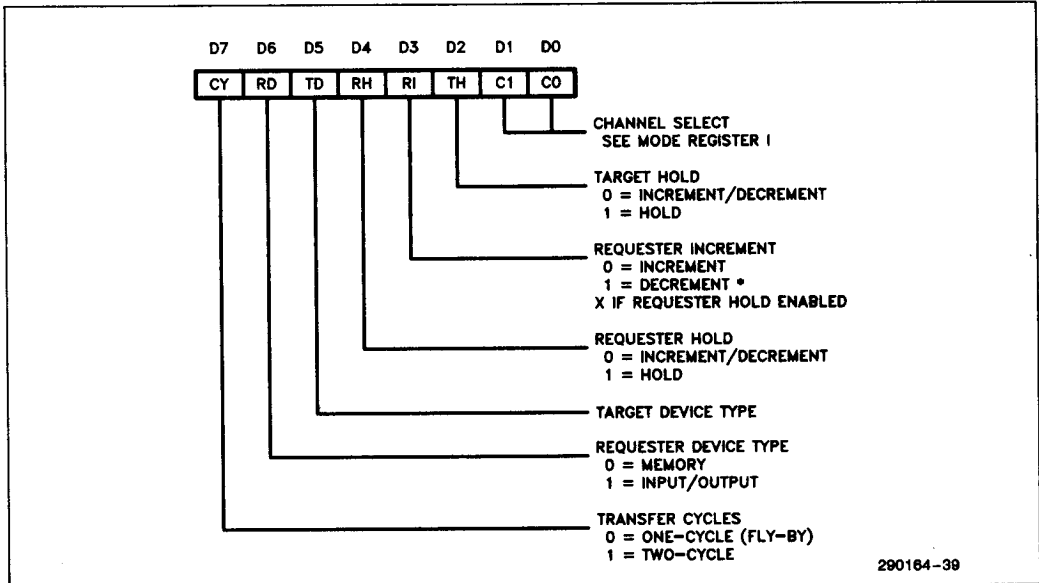

*Target and Requester DECREMENT is allowed only for byte transfers.

Software Request Register (read/write)

Port Addresses— Channels 0–3—0009H
 Channels 4–7—00C9H

Write Format: Software DMA Service Request

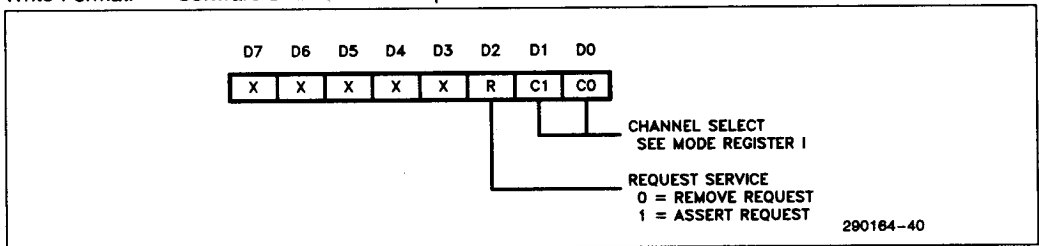

Read Format: Software Requests Pending

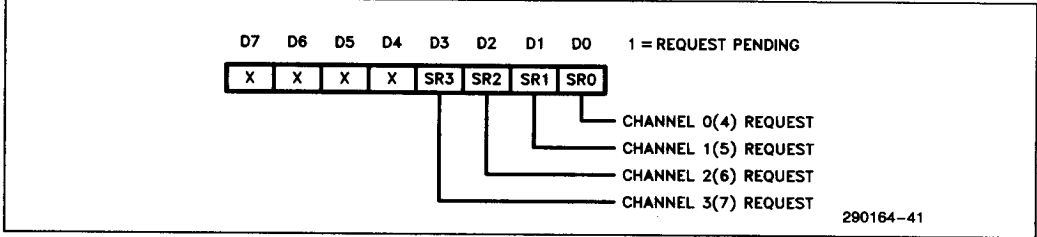

Mask Set/Reset Register Individual Channel Mask (write only)

Port Addresses— Channels 0-3—000AH
Channels 4-7—00CAH

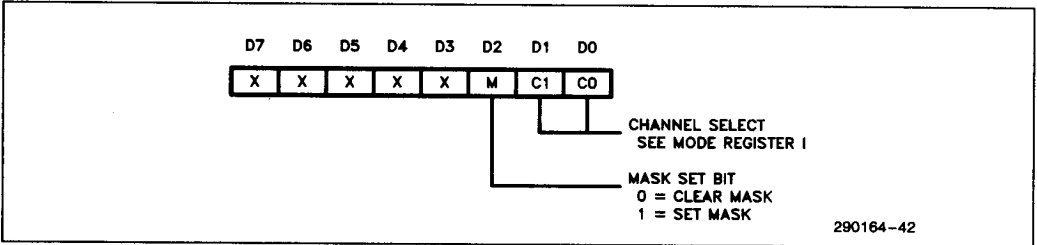

Mask Read/Write Register Group Channel Mask (read/write)

Port Addresses— Channels 0-3—000FH
Channels 4-7—00CFH

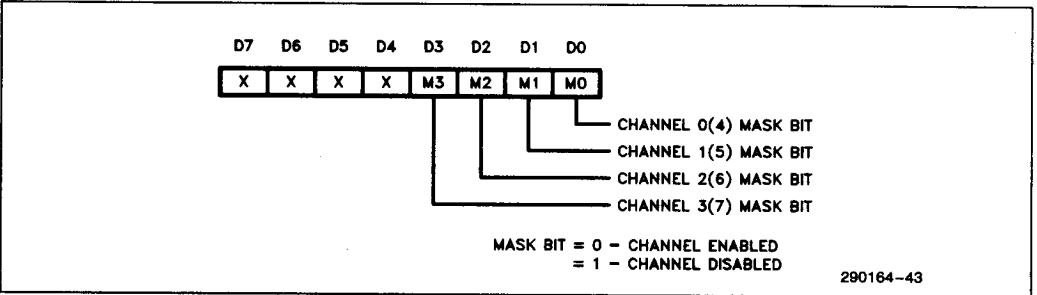

Status Register Channel Process Status (read only)

Port Addresses— Channels 0–3—0008H
 Channels 4–7—00C8H

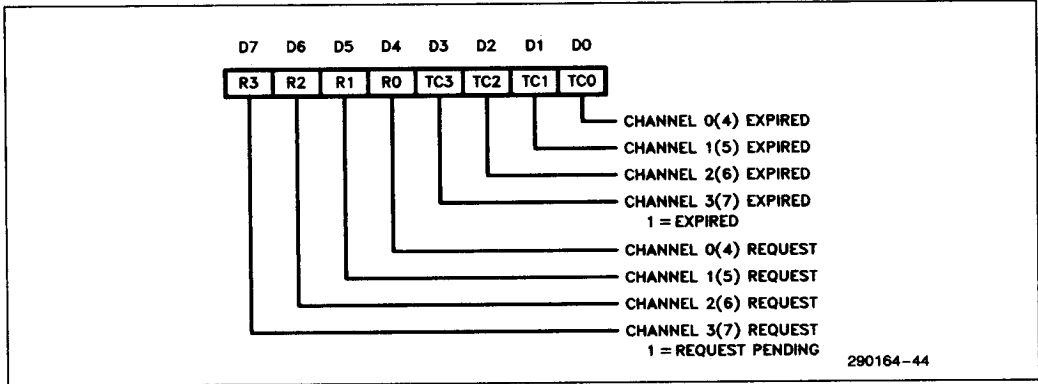

Bus Size Register Set Data Path Width (write only)

Port Addresses— Channels 0–3—0018H
 Channels 4–7—00D8H

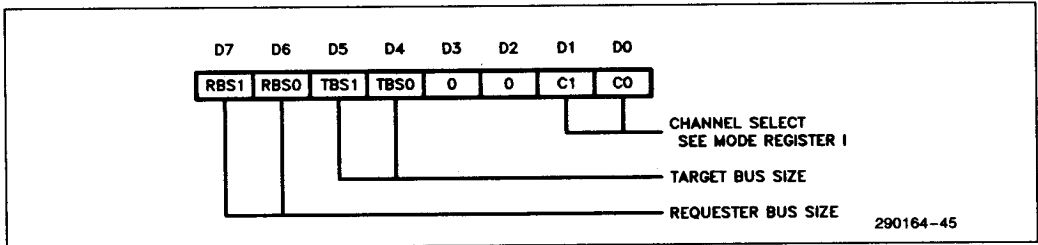

Bus Size Encoding:

- 00 = Reserved by Intel 10 = 16-bit Bus
- 01 = 32-bit Bus* 11 = 8-bit Bus

*If programmed as 32-bit bus width, the corresponding device will be accessed in two 16-bit cycles provided that the data is aligned within word boundary.

Chaining Register (read/write)

Port Addresses— Channels 0–3—0019H
 Channels 4–7—00D9H

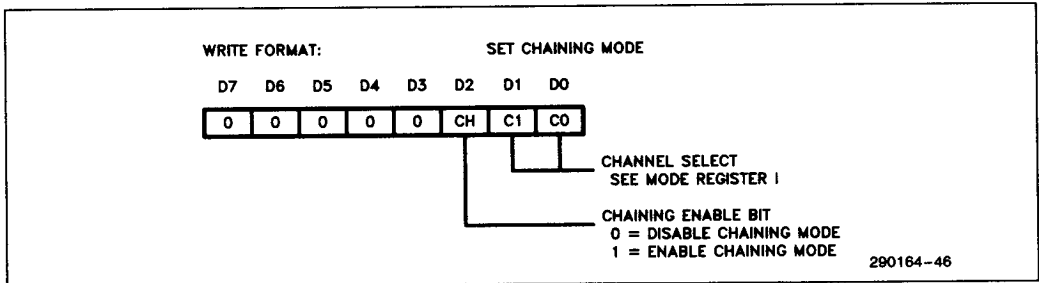

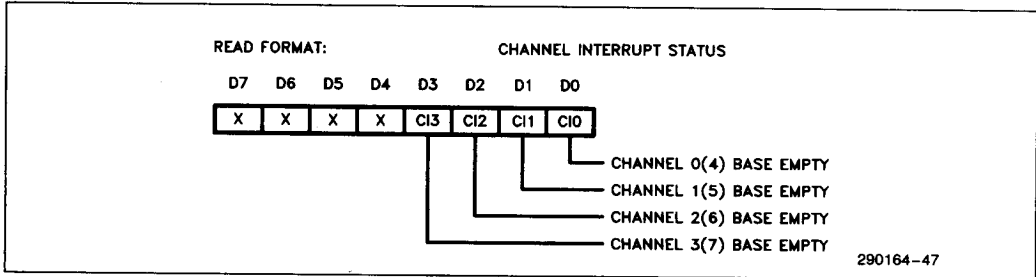

290164-47

3.8 8237A Compatibility

The register arrangement of the 82370 DMA Controller is a superset of the 8237A DMA Controller. Functionally the 82370 DMA Controller is very different from the 8237A. Most of the functions of the 8237A are performed also by the 82370. The following discussion points out the differences between the 8237A and the 82370.

The 8237A is limited to transfers between I/O and memory only (except in one special case, where two channels can be used to perform memory-to-memory transfers). The 82370 DMA Controller can transfer between any combination of memory and I/O. Several other features of the 8237A are enhanced or expanded in the 82370 and other features are added.

The 8237A is an 8-bit only DMA device. For programming compatibility, all of the 8-bit registers are preserved in the 82370. The 82370 is programmed via 8-bit registers. The address registers in the 82370 are 24-bit registers in order to support the 80376's 24-bit bus. The Byte Count Registers are 24-bit registers, allowing support of larger data blocks than possible with the 8237A.

All of the 8237A's operating modes are supported by the 82370 (except the cumbersome two-channel memory-to-memory transfer). The 82370 performs memory-to-memory transfers using only one channel. The 82370 has the added features of buffer pipelining (Buffer Chaining Process) and programmable priority levels.

The 82370 also adds the feature of address registers for both destination and source. These addresses may be incremented, decremented, or held constant, as required by the application of the individual channel. This allows any combination of destination and source device.

Each DMA channel has associated with it a Target and a Requester. In the 8237A, the Target is the device which can be accessed by the address register, the Requester is the device which is accessed by the DMA Acknowledge signals and must be an I/O device.

4.0 PROGRAMMABLE INTERRUPT CONTROLLER (PIC)

4.1 Functional Description

The 82370 Programmable Interrupt Controller (PIC) consists of three enhanced 82C59A Interrupt Controllers. These three controllers together provide 15 external and 5 internal interrupt request inputs. Each external request input can be cascaded with an additional 82C59A slave controller. This scheme allows the 82370 to support a maximum of 120 (15 x 8) external interrupt request inputs.

Following one or more interrupt requests, the 82370 PIC issues an interrupt signal to the 80376. When the 80376 host processor responds with an interrupt acknowledge signal, the PIC will arbitrate between the pending interrupt requests and place the interrupt vector associated with the highest priority pending request on the data bus.

The major enhancement in the 82370 PIC over the 82C59A is that each of the interrupt request inputs can be individually programmed with its own interrupt vector, allowing more flexibility in interrupt vector mapping.

4.1.1 INTERNAL BLOCK DIAGRAM

The block diagram of the 82370 Programmable Interrupt Controller is shown in Figure 4-1. Internally,

1

the PIC consists of three 82C59A banks: A, B and C. The three banks are cascaded to one another: C is cascaded to B, B is cascaded to A. The INT output of Bank A is used externally to interrupt the 80376.

Bank A has nine interrupt request inputs (two are unused), and Banks B and C have eight interrupt request inputs. Of the fifteen external interrupt request inputs, two are shared by other functions. Specifically, the Interrupt Request 3 input (IRQ3#) can be used as the Timer 2 output (TOUT2#). This pin can be used in three different ways: IRQ3# input only, TOUT2# output only, or using TOUT2# to generate an IRQ3# interrupt request. Also, the Interrupt Request 9 input (IRQ9#) can be used as DMA Request 4 input (DREQ 4). Typically, only IRQ9# or DREQ4 can be used at a time.

4.1.2 INTERRUPT CONTROLLER BANKS

All three banks are identical, with the exception of the IRQ1.5 on Bank A. Therefore, only one bank will be discussed. In the 82370 PIC, all external requests can be cascaded into and each interrupt controller bank behaves like a master. As compared to the 82C59A, the enhancements in the banks are:

- All interrupt vectors are individually programmable. (In the 82C59A, the vectors must be programmed in eight consecutive interrupt vector locations.)
- The cascade address is provided on the Data Bus (D0-D7). (In the 82C59A, three dedicated control signals (CAS0, CAS1, CAS2) are used for master/slave cascading.)

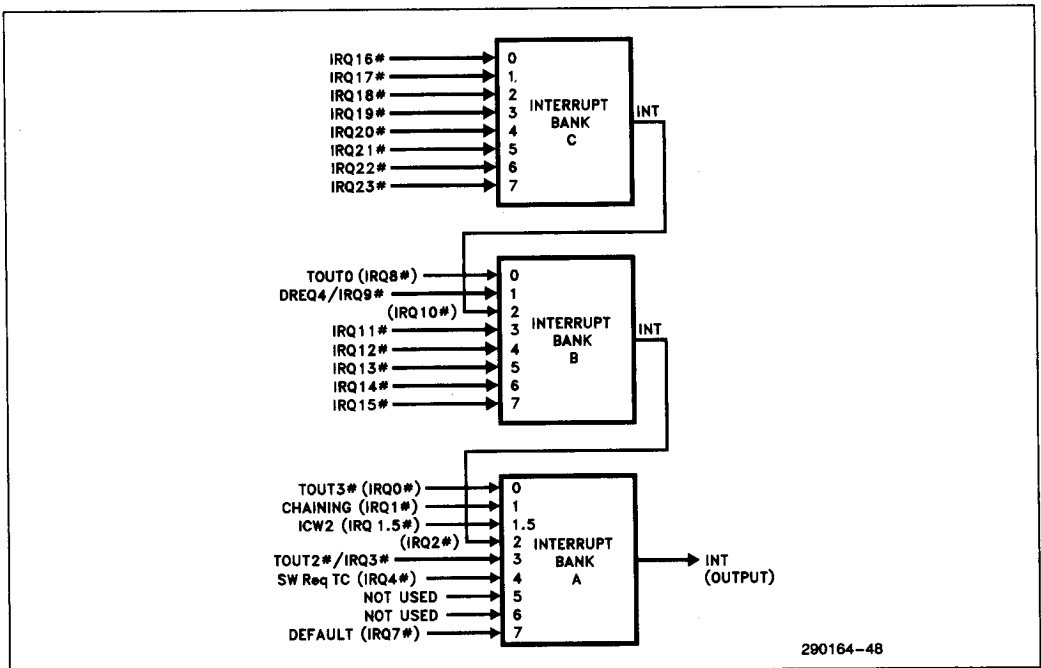

Figure 4-1. Interrupt Controller Block Diagram

The block diagram of a bank is shown in Figure 4-2. As can be seen from this figure, the bank consists of six major blocks: the Interrupt Request Register (IRR), the In-Service Register (ISR), the Interrupt Mask Register (IMR), the Priority Resolver (PR), the Vector Registers (VR), and the Control Logic. The functional description of each block is included below.

INTERRUPT REQUEST (IRR) AND IN-SERVICE REGISTER (ISR)

The interrupts at the Interrupt Request (IRQ) input lines are handled by two registers in cascade, the Interrupt Request Register (IRR) and the In-Service Register (ISR). The IRR is used to store all interrupt levels which are requesting service; and the ISR is used to store all interrupt levels which are being serviced.

PRIORITY RESOLVER (PR)

This logic block determines the priorities of the bits set in the IRR. The highest priority is selected and strobed into the corresponding bit of the ISR during an Interrupt Acknowledge cycle.

INTERRUPT MASK REGISTER (IMR)

The IMR stores the bits which mask the interrupt lines to be masked (disabled). The IMR operates on the IRR. Masking of a higher priority input will not affect the interrupt request lines of lower priority.

VECTOR REGISTERS (VR)

This block contains a set of Vector Registers, one for each interrupt request line, to store the pre-programmed interrupt vector number. The corresponding vector number will be driven onto the Data Bus of the 82370 during the Interrupt Acknowledge cycle.

CONTROL LOGIC

The Control Logic coordinates the overall operations of the other internal blocks within the same bank. This logic will drive the Interrupt Output signal (INT) HIGH when one or more unmasked interrupt inputs are active (LOW). The INT output signal goes directly to the 80376 (in bank A) or to another bank to which this bank is cascaded (see Figure 4-1). Also,

1

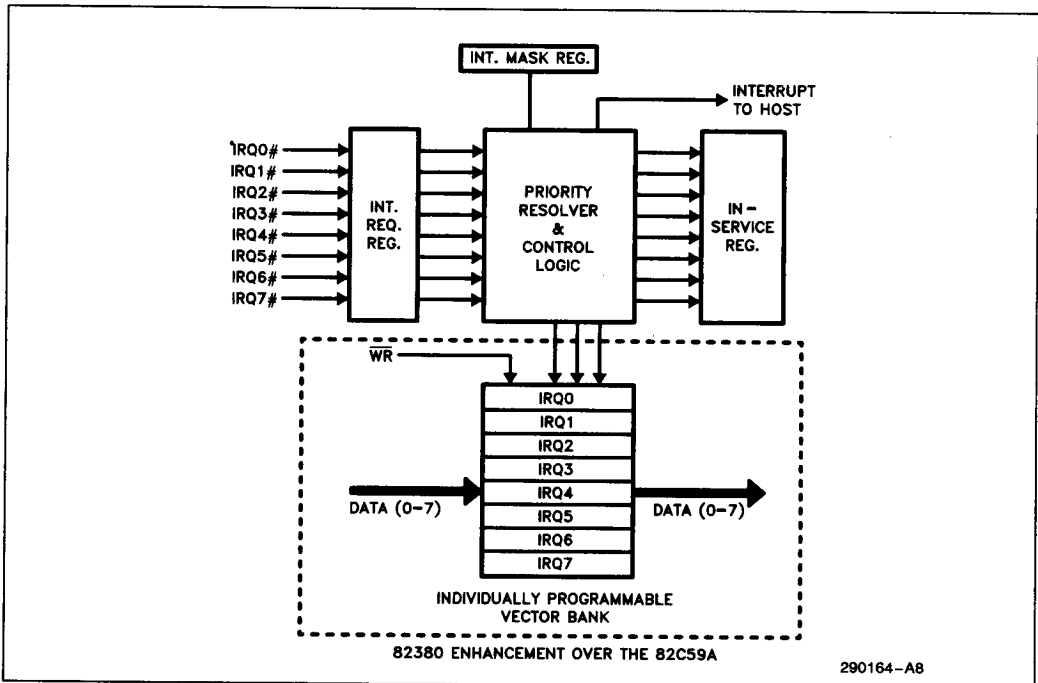

Figure 4-2. Interrupt Bank Block Diagram

this logic will recognize an Interrupt Acknowledge cycle (via M/IO#, D/C# and W/R# signals). During this bus cycle, the Control Logic will enable the corresponding Vector Register to drive the interrupt vector onto the Data Bus.

In bank A, the Control Logic is also responsible for handling the special ICW2 interrupt request input (IRQ1.5).

4.2 Interface Signals

4.2.1 INTERRUPT INPUTS

There are 15 external Interrupt Request inputs and 5 internal Interrupt Requests. The external request inputs are: IRQ3#, IRQ9#, IRQ11# to IRQ23#. They are shown in bold arrows in Figure 4-1. All IRQ inputs are active LOW and they can be programmed (via a control bit in the Initialization Command Word 1 (ICW1)) to be either edge-triggered or level-triggered. In order to be recognized as a valid interrupt request, the interrupt input must be active (LOW) until the first INTA cycle (see Bus Functional Description). Note that all 15 external Interrupt Request inputs have weak internal pull-up resistors.

As mentioned earlier, an 82C59A can be cascaded to each external interrupt input to expand the interrupt capacity to a maximum of 120 levels. Also, two of the interrupt inputs are dual functions: IRQ3# can be used as Timer 2 output (TOUT2#) and IRQ9# can be used as DREQ4 input. IRQ3# is a bidirectional dual function pin. This interrupt request input is wired-OR with the output of Timer 2 (TOUT2#). If only IRQ3# function is to be used, Timer 2 should be programmed so that OUT2 is LOW. Note that TOUT2# can also be used to generate an interrupt request to IRQ3# input.

The five internal interrupt requests serve special system functions. They are shown in Table 4-1. The following paragraphs describe these interrupts.

Table 4-1. 82370 Internal Interrupt Requests

| Interrupt Request | Interrupt Source |
|-------------------|------------------------|
| IRQ0# | Timer 3 Output (TOUT3) |
| IRQ8# | Timer 0 Output (TOUT0) |
| IRQ1# | DMA Chaining Request |
| IRQ4# | DMA Terminal Count |
| IRQ1.5# | ICW2 Written |

TIMER 0 AND TIMER 3 INTERRUPT REQUESTS

IRQ8# and IRQ0# interrupt requests are initiated by the output of Timers 0 and 3, respectively. Each of these requests is generated by an edge-detector flip-flop.

1-658

The flip-flops are activated by the following conditions:

Set — Rising edge of timer output (TOUT);

Clear — Interrupt acknowledge for this request; OR Request is masked (disabled); OR Hardware Reset.

CHAINING AND TERMINAL COUNT INTERRUPTS

These interrupt requests are generated by the 82370 DMA Controller. The chaining request (IRQ1#) indicates that the DMA Base Register is not loaded. The Terminal Count request (IRQ4#) indicates that a software DMA request was cleared.

ICW2 INTERRUPT REQUEST

Whenever an Initialization Control Word 2 (ICW2) is written to a Bank, a special ICW2 interrupt request is generated. The interrupt will be cleared when the newly programmed ICW2 Register is read. This interrupt request is in Bank A at level 1.5. This interrupt request is internally ORed with the Cascaded Request from Bank B and is always assigned a higher priority than the Cascaded Request.

This special interrupt is provided to support compatibility with the original 82C59A. A detailed description of this interrupt is discussed in the Programming section.

DEFAULT INTERRUPT (IRQ7#)

During an Interrupt Acknowledge cycle, if there is no active pending request, the PIC will automatically generate a default vector. This vector corresponds to the IRQ7# vector in bank A.

4.2.2 INTERRUPT OUTPUT (INT)

The INT output pin is taken directly from bank A. This signal should be tied to the Maskable Interrupt Request (INTR) of the 80376. When this signal is active (HIGH), it indicates that one or more internal/external interrupt requests are pending. The 80376 is expected to respond with an interrupt acknowledge cycle.

4.3 Bus Functional Description

The INT output of bank A will be activated as a result of any unmasked interrupt request. This may be a non-cascaded or cascaded request. After the PIC has driven the INT signal HIGH, the 80376 will respond by performing two interrupt acknowledge cycles. The timing diagram in Figure 4-3 shows a typical interrupt acknowledge process between the 82370 and the 80376 CPU.

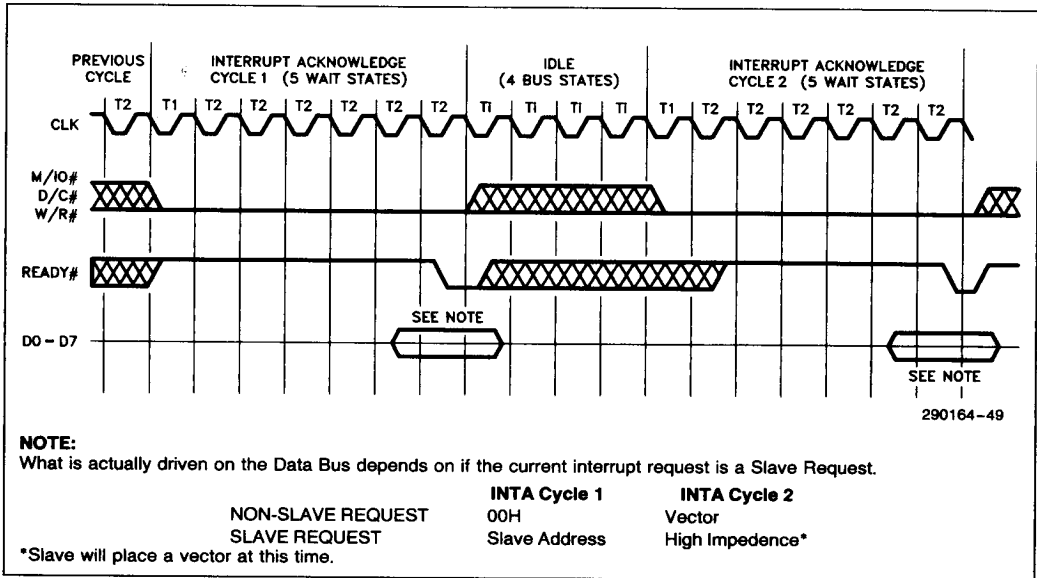

Figure 4-3. Interrupt Acknowledge Cycle

After activating the INT signal, the 82370 monitors the status lines (M/IO#, D/C#, W/R#) and waits for the 80376 to initiate the first interrupt acknowledge cycle. In the 80376 environment, two successive interrupt acknowledge cycles (INTA) marked by M/IO# = LOW, D/C# = LOW, and W/R# = LOW are performed. During the first INTA cycle, the PIC will determine the highest priority request. Assuming this interrupt input has no external Slave Controller cascaded to it, the 82370 will drive the Data Bus with 00H in the first INTA cycle. During the second INTA cycle, the 82370 PIC will drive the Data Bus with the corresponding pre-programmed interrupt vector.

If the PIC determines (from the ICW3) that this interrupt input has an external Slave Controller cascaded to it, it will drive the Data Bus with the specific Slave Cascade Address (instead of 00H) during the first INTA cycle. This Slave Cascade Address is the pre-programmed content in the corresponding Vector Register. This means that no Slave Address should be chosen to be 00H. Note that the Slave Address and Interrupt Vector are different interpretations of the same thing. They are both the contents of the programmable Vector Register. During the second INTA cycle, the Data Bus will be floated so that the external Slave Controller can drive its interrupt vector on the bus. Since the Slave Interrupt Controller resides on the system bus, bus transceiver enable and direction control logic must take this into consideration.

In order to have a successful interrupt service, the interrupt request input must be held valid (LOW) until the beginning of the first interrupt acknowledge cycle. If there is no pending interrupt request when the first INTA cycle is generated, the PIC will generate a default vector, which is the IRQ7 vector (Bank A, level 7).

According to the Bus Cycle definition of the 80376, there will be four Bus Idle States between the two interrupt acknowledge cycles. These idle bus cycles will be initiated by the 80376. Also, during each interrupt acknowledge cycle, the internal Wait State Generator of the 82370 will automatically generate the required number of wait states for internal delays.

4.4 Modes of Operation

A variety of modes and commands are available for controlling the 82370 PIC. All of them are programmable; that is, they may be changed dynamically under software control. In fact, each bank can be programmed individually to operate in different modes. With these modes and commands, many possible configurations are conceivable, giving the user enough versatility for almost any interrupt controlled application.

This section is not intended to show how the 82370 PIC can be programmed. Rather, it describes the operation in different modes.

4.4.1 END-OF-INTERRUPT

Upon completion of an interrupt service routine, the interrupted bank needs to be notified so its ISR can be updated. This allows the PIC to keep track of which interrupt levels are in the process of being serviced and their relative priorities. Three different End-Of-Interrupt (EOI) formats are available. They are: Non-Specific EOI Command, Specific EOI Command, and Automatic EOI Mode. Selection of which EOI to use is dependent upon the interrupt operations the user wishes to perform.

If the 82370 is NOT programmed in the Automatic EOI Mode, an EOI command must be issued by the 80376 to the specific 82370 PIC Controller Bank. Also, if this controller bank is cascaded to another internal bank, an EOI command must also be sent to the bank to which this bank is cascaded. For example, if an interrupt request of Bank C in the 82370 PIC is serviced, an EOI should be written into Bank C, Bank B and Bank A. If the request comes from an external interrupt controller cascaded to Bank C, then an EOI should be written into the external controller as well.

NON-SPECIFIC EOI COMMAND

A Non-Specific EOI command sent from the 80376 lets the 82370 PIC bank know when a service routine has been completed, without specification of its exact interrupt level. The respective interrupt bank automatically determines the interrupt level and resets the correct bit in the ISR.

To take advantage of the Non-Specific EOI, the interrupt bank must be in a mode of operation in which it can predetermine its in-service routine levels. For this reason, the Non-Specific EOI command should only be used when the most recent level acknowledged and serviced is always the highest priority level (i.e. in the Fully Nested Mode structure to be described below). When the interrupt bank receives a Non-Specific EOI command, it simply resets the highest priority ISR bit to indicate that the highest priority routine in service is finished.

Special consideration should be taken when deciding to use the Non-Specific EOI command. Here are two operating conditions in which it is best NOT used since the Fully Nested Mode structure will be destroyed:

- Using the Set Priority command within an interrupt service routine.
- Using a Special Mask Mode.

These conditions are covered in more detail in their own sections, but are listed here for reference.

SPECIFIC EOI COMMAND

Unlike a Non-Specific EOI command which automatically resets the highest priority ISR bit, a Specific EOI command specifies an exact ISR bit to be reset. Any one of the IRQ levels of an interrupt bank can be specified in the command.

The Specific EOI command is needed to reset the ISR bit of a completed service routine whenever the interrupt bank is not able to automatically determine it. The Specific EOI command can be used in all conditions of operation, including those that prohibit Non-Specific EOI command usage mentioned above.

AUTOMATIC EOI MODE

When programmed in the Automatic EOI Mode, the 80376 no longer needs to issue a command to notify the interrupt bank it has completed an interrupt routine. The interrupt bank accomplishes this by performing a Non-Specific EOI automatically at the end of the second INTA cycle.

Special consideration should be taken when deciding to use the Automatic EOI Mode because it may disturb the Fully Nested Mode structure. In the Automatic EOI Mode, the ISR bit of a routine in service is reset right after it is acknowledged, thus leaving no designation in the ISR that a service routine is being executed. If any interrupt request within the same bank occurs during this time and interrupts are enabled, it will get serviced regardless of its priority. Therefore, when using this mode, the 80376 should keep its interrupt request input disabled during execution of a service routine. By doing this, higher priority interrupt levels will be serviced only after the completion of a routine in service. This guideline restores the Fully Nested Mode structure. However, in this scheme, a routine in service cannot be interrupted since the host's interrupt request input is disabled.

4.4.2 INTERRUPT PRIORITIES

The 82370 PIC provides various methods for arranging the interrupt priorities of the interrupt request inputs to suit different applications. The following subsections explain these methods in detail.

4.4.2.1 Fully Nested Mode

The Fully Nested Mode of operation is a general purpose priority mode. This mode supports a multi-level interrupt structure in which all of the Interrupt Request (IRQ) inputs within one bank are arranged from highest to lowest.

Unless otherwise programmed, the Fully Nested Mode is entered by default upon initialization. At this time, IRQ0# is assigned the highest priority (priority=0) and IRQ7# the lowest (priority=7). This default priority can be changed, as will be explained later in the Rotating Priority Mode.

When an interrupt is acknowledged, the highest priority request is determined from the Interrupt Request Register (IRR) and its vector is placed on the bus. In addition, the corresponding bit in the In-Service Register (ISR) is set to designate the routine in service. This ISR bit will remain set until the 80376 issues an End Of Interrupt (EOI) command immediately before returning from the service routine; or alternately, if the Automatic End Of Interrupt (AEOI) bit is set, the ISR bit will be reset at the end of the second INTA cycle.

While the ISR bit is set, all further interrupts of the same or lower priority are inhibited. Higher level interrupts can still generate an interrupt, which will be acknowledged only if the 80376 internal interrupt enable flip-flop has been reenabled (through software inside the current service routine).

4.4.2.2 Automatic Rotation—Equal Priority Devices

Automatic rotation of priorities serves in applications where the interrupting devices are of equal priority

within an interrupt bank. In this kind of environment, once a device is serviced, all other equal priority peripherals should be given a chance to be serviced before the original device is serviced again. This is accomplished by automatically assigning a device the lowest priority after being serviced. Thus, in the worst case, the device would have to wait until all other peripherals connected to the same bank are serviced before it is serviced again.

There are two methods of accomplishing automatic rotation. One is used in conjunction with the Non-Specific EOI command and the other is used with the Automatic EOI mode. These two methods are discussed below.

ROTATE ON NON-SPECIFIC EOI COMMAND

When the Rotate On Non-Specific EOI command is issued, the highest ISR bit is reset as in a normal Non-Specific EOI command. However, after it is reset, the corresponding Interrupt Request (IRQ) level is assigned the lowest priority. Other IRQ priorities rotate to conform to the Fully Nested Mode based on the newly assigned low priority.

Figure 4-4 shows how the Rotate On Non-Specific EOI command affects the interrupt priorities. Assume the IRQ priorities were assigned with IRQ0 the highest and IRQ7 the lowest. IRQ6 and IRQ4 are

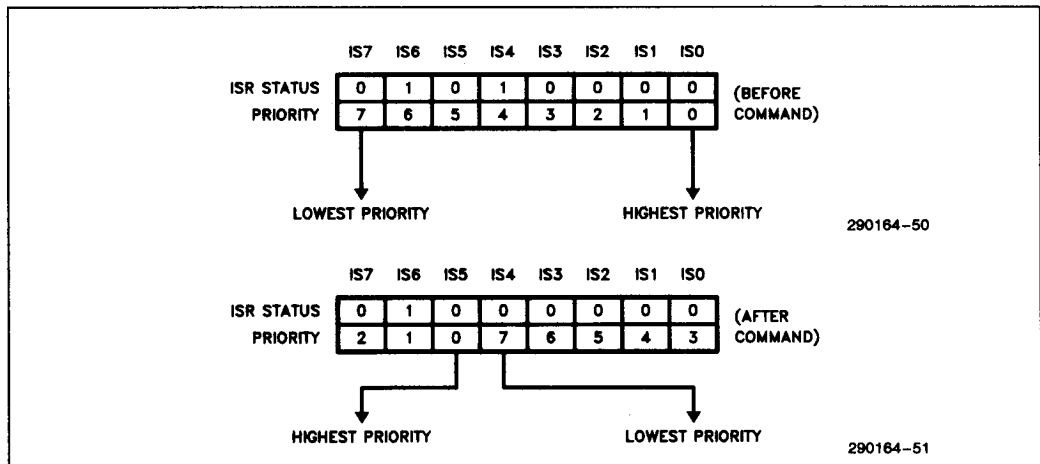

Figure 4-4. Rotate On Non-Specific EOI Command

already in service but neither is completed. Being the higher priority routine, IRQ4 is necessarily the routine being executed. During the IRQ4 routine, a rotate on Non-Specific EOI command is executed. When this happens, Bit 4 in the ISR is reset. IRQ4 then becomes the lowest priority and IRQ5 becomes the highest.

ROTATE ON AUTOMATIC EOI MODE

The Rotate On Automatic EOI Mode works much like the Rotate On Non-Specific EOI Command. The main difference is that priority rotation is done automatically after the second INTA cycle of an interrupt request. To enter or exit this mode, a Rotate-On-Automatic-EOI Set Command and Rotate-On-Automatic-EOI Clear Command is provided. After this mode is entered, no other commands are needed as in the normal Automatic EOI Mode. However, it must be noted again that when using any form of the Automatic EOI Mode, special consideration should be taken. The guideline presented in the Automatic EOI Mode also applies here.

4.4.2.3 Specific Rotation-Specific Priority

Specific rotation gives the user versatile capabilities in interrupt controlled operations. It serves in those applications in which a specific device's interrupt priority must be altered. As opposed to Automatic Rotation which will automatically set priorities after each interrupt request is serviced, specific rotation is completely user controlled. That is, the user selects which interrupt level is to receive the lowest or the highest priority. This can be done during the main program or within interrupt routines. Two specific ro-

tation commands are available to the user: Set Priority Command and Rotate On Specific EOI Command.

SET PRIORITY COMMAND

The Set Priority Command allows the programmer to assign an IRQ level the lowest priority. All other interrupt levels will conform to the Fully Nested Mode based on the newly assigned low priority.

ROTATE ON SPECIFIC EOI COMMAND

The Rotate On Specific EOI Command is literally a combination of the Set Priority Command and the Specific EOI Command. Like the Set Priority Command, a specified IRQ level is assigned lowest priority. Like the Specific EOI Command, a specified level will be reset in the ISR. Thus, this command accomplishes both tasks in one single command.

4.4.2.4 Interrupt Priority Mode Summary

In order to simplify understanding the many modes of interrupt priority, Table 4-2 is provided to bring out their summary of operations.

4.4.3 INTERRUPT MASKING

VIA INTERRUPT MASK REGISTER

Each bank in the 82370 PIC has an Interrupt Mask Register (IMR) which enhances interrupt control ca-

Table 4-2. Interrupt Priority Mode Summary

| Interrupt Priority Mode | Operation Summary | Effect On Priority After EOI | |
|--|---|---|---|
| | | Non-Specific/Automatic | Specific |
| Fully-Nested Mode | IRQ0# - Highest Priority IRQ7# - Lowest Priority | No change in priority. Highest ISR bit is reset. | Not Applicable. |
| Automatic Rotation (Equal Priority Devices) | Interrupt level just serviced is the lowest priority. Other priorities rotate to conform to Fully-Nested Mode. | Highest ISR bit is reset and the corresponding level becomes the lowest priority. | Not Applicable. |
| Specific Rotation (Specific Priority Devices) | User specifies the lowest priority level. Other priorities rotate to conform to Fully-Nested Mode. | Not Applicable. | As described under "Operation Summary". |

pabilities. This IMR allows individual IRQ masking. When an IRQ is masked, its interrupt request is disabled until it is unmasked. Each bit in the 8-bit IMR disables one interrupt channel if it is set (HIGH). Bit 0 masks IRQ0, Bit 1 masks IRQ1 and so forth. Masking an IRQ channel will only disable the corresponding channel and does not affect the others' operations.

The IMR acts only on the output of the IRR. That is, if an interrupt occurs while its IMR bit is set, this request is not "forgotten". Even with an IRQ input masked, it is still possible to set the IRR. Therefore, when the IMR bit is reset, an interrupt request to the 80376 will then be generated, providing that the IRQ request remains active. If the IRQ request is removed before the IMR is reset, the Default Interrupt Vector (Bank A, level 7) will be generated during the interrupt acknowledge cycle.

SPECIAL MASK MODE

In the Fully Nested Mode, all IRQ levels of lower priority than the routine in service are inhibited. However, in some applications, it may be desirable to let a lower priority interrupt request to interrupt the routine in service. One method to achieve this is by using the Special Mask Mode. Working in conjunction with the IMR, the Special Mask Mode enables interrupts from all levels except the level in service. This is usually done inside an interrupt service routine by masking the level that is in service and then issuing the Special Mask Mode Command. Once the Special Mask Mode is enabled, it remains in effect until it is disabled.

4.4.4 EDGE OR LEVEL INTERRUPT TRIGGERING

Each bank in the 82370 PIC can be programmed independently for either edge or level sensing for the

interrupt request signals. Recall that all IRQ inputs are active LOW. Therefore, in the edge triggered mode, an active edge is defined as an input transition from an inactive (HIGH) to active (LOW) state. The interrupt input may remain active without generating another interrupt. During level triggered mode, an interrupt request will be recognized by an active (LOW) input, and there is no need for edge detection. However, the interrupt request must be removed before the EOI Command is issued, or the 80376 must be disabled to prevent a second false interrupt from occurring.

In either modes, the interrupt request input must be active (LOW) during the first INTA cycle in order to be recognized. Otherwise, the Default Interrupt Vector will be generated at level 7 of Bank A.

4.4.5 INTERRUPT CASCADING

As mentioned previously, the 82370 allows for external Slave interrupt controllers to be cascaded to any of its external interrupt request pins. The 82370 PIC indicates that an external Slave Controller is to be serviced by putting the contents of the Vector Register associated with the particular request on the 80376 Data Bus during the first INTA cycle (instead of 00H during a non-slave service). The external logic should latch the vector on the Data Bus using the INTA status signals and use it to select the external Slave Controller to be serviced (see Figure 4-5). The selected Slave will then respond to the second INTA cycle and place its vector on the Data Bus. This method requires that if external Slave Controllers are used in the system, no vector should be programmed to 00H.

Since the external Slave Cascade Address is provided on the Data Bus during INTA cycle 1, an external latch is required to capture this address for the Slave Controller. A simple scheme is depicted in Figure 4-5 below.

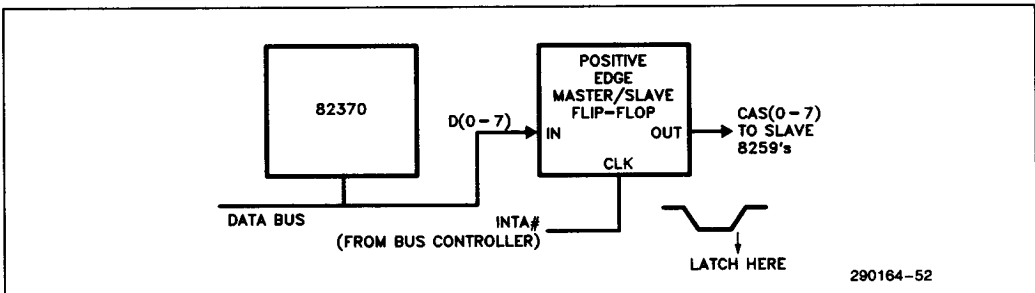

Figure 4-5. Slave Cascade Address Capturing

1

4.4.5.1 Special Fully Nested Mode

This mode will be used where cascading is employed and the priority is to be conserved within each Slave Controller. The Special Fully Nested Mode is similar to the "regular" Fully Nested Mode with the following exceptions:

- When an interrupt request from a Slave Controller is in service, this Slave Controller is not locked out from the Master's priority logic. Further interrupt requests from the higher priority logic within the Slave Controller will be recognized by the 82370 PIC and will initiate interrupts to the 80376. In comparing to the "regular" Fully Nested Mode, the Slave Controller is masked out when its request is in service and no higher requests from the same Slave Controller can be serviced.
- Before exiting the interrupt service routine, the software has to check whether the interrupt serviced was the only request from the Slave Controller. This is done by sending a Non-Specific EOI Command to the Slave Controller and then reading its In Service Register. If there are no requests in the Slave Controller, a Non-Specific EOI can be sent to the corresponding 82370 PIC bank also. Otherwise, no EOI should be sent.

4.4.6 READING INTERRUPT STATUS

The 82370 PIC provides several ways to read different status of each interrupt bank for more flexible interrupt control operations. These include polling the highest priority pending interrupt request and reading the contents of different interrupt status registers.

4.4.6.1 Poll Command

The 82370 PIC supports status polling operations with the Poll Command. In a Poll Command, the pending interrupt request with the highest priority can be determined. To use this command, the INT output is not used, or the 80376 interrupt is disabled. Service to devices is achieved by software using the Poll Command.

This mode is useful if there is a routine command common to several levels so that the INTA sequence is not needed. Another application is to use the Poll Command to expand the number of priority levels.

Notice that the ICW2 mechanism is not supported for the Poll Command. However, if the Poll Command is used, the programmable Vector Registers are of no concern since no INTA cycle will be generated.

4.4.6.2 Reading Interrupt Registers

The contents of each interrupt register (IRR, ISR, and IMR) can be read to update the user's program on the present status of the 82370 PIC. This can be a versatile tool in the decision making process of a service routine, giving the user more control over interrupt operations.

The reading of the IRR and ISR contents can be performed via the Operation Control Word 3 by using a Read Status Register Command and the content of IMR can be read via a simple read operation of the register itself.

4.5 Register Set Overview

Each bank of the 82370 PIC consists of a set of 8-bit registers to control its operations. The address map of all the registers is shown in Table 4-3 below. Since all three register sets are identical in functions, only one set will be described.

Functionally, each register set can be divided into five groups. They are: the four Initialization Command Words (ICW's), the three Operation Control Words (OCW's), the Poll/Interrupt Request/In-Service Register, the Interrupt Mask Register, and the Vector Registers. A description of each group follows.

Table 4-3. Interrupt Controller Register Address Map

| Port Address | Access | Register Description |
|---------------------|---------------|--|
| 20H | Write Read | Bank B ICW1, OCW2, or OCW3 Bank B Poll, Request or In-Service Status Register |
| 21H | Write Read | Bank B ICW2, ICW3, ICW4, OCW1 Bank B Mask Register |
| 22H | Read | Bank B ICW2 |
| 28H | Read/Write | IRQ8 Vector Register |
| 29H | Read/Write | IRQ9 Vector Register |
| 2AH | Read/Write | Reserved |
| 2BH | Read/Write | IRQ11 Vector Register |
| 2CH | Read/Write | IRQ12 Vector Register |
| 2DH | Read/Write | IRQ13 Vector Register |
| 2EH | Read/Write | IRQ14 Vector Register |
| 2FH | Read/Write | IRQ15 Vector Register |
| A0H | Write Read | Bank C ICW1, OCW2, or OCW3 Bank C Poll, Request or In-Service Status Register |
| A1H | Write Read | Bank C ICW2, ICW3, ICW4, OCW1 Bank C Mask Register |
| A2H | Read | Bank C ICW2 |
| A8H | Read/Write | IRQ16 Vector Register |
| A9H | Read/Write | IRQ17 Vector Register |
| AAH | Read/Write | IRQ18 Vector Register |
| ABH | Read/Write | IRQ19 Vector Register |
| ACH | Read/Write | IRQ20 Vector Register |
| ADH | Read/Write | IRQ21 Vector Register |
| AEH | Read/Write | IRQ22 Vector Register |
| AFH | Read/Write | IRQ23 Vector Register |
| 30H | Write Read | Bank A ICW1, OCW2, or OCW3 Bank A Poll, Request or In-Service Status Register |
| 31H | Write Read | Bank A ICW2, ICW3, ICW4, OCW1 Bank A Mask Register |
| 32H | Read | Bank ICW2 |
| 38H | Read/Write | IRQ0 Vector Register |
| 39H | Read/Write | IRQ1 Vector Register |
| 3AH | Read/Write | IRQ1.5 Vector Register |
| 3BH | Read/Write | IRQ3 Vector Register |
| 3CH | Read/Write | IRQ4 Vector Register |
| 3DH | Read/Write | Reserved |
| 3EH | Read/Write | Reserved |
| 3FH | Read/Write | IRQ7 Vector Register |

1



4.5.1 INITIALIZATION COMMAND WORDS (ICW)

Before normal operation can begin, the 82370 PIC must be brought to a known state. There are four 8-bit Initialization Command Words in each interrupt bank to setup the necessary conditions and modes for proper operation. Except for the second command word (ICW2) which is a read/write register, the other three are write-only registers. Without going into detail of the bit definitions of the command words, the following subsections give a brief description of what functions each command word controls.

ICW1

The ICW1 has three major functions. They are:

- To select between the two IRQ input triggering modes (edge- or level-triggered);
- To designate whether or not the interrupt bank is to be used alone or in the cascade mode. If the cascade mode is desired, the interrupt bank will accept ICW3 for further cascade mode programming. Otherwise, no ICW3 will be accepted;
- To determine whether or not ICW4 will be issued; that is, if any of the ICW4 operations are to be used.

ICW2

ICW2 is provided for compatibility with the 82C59A only. Its contents do not affect the operation of the interrupt bank in any way. Whenever the ICW2 of any of the three banks is written into, an interrupt is generated from bank A at level 1.5. The interrupt request will be cleared after the ICW2 register has been read by the 80376. The user is expected to program the corresponding vector register or to use it as an indicator that an attempt was made to alter the contents. Note that each ICW2 register has different addresses for read and write operations.

ICW3

The interrupt bank will only accept an ICW3 if programmed in the external cascade mode (as indicated in ICW1). ICW3 is used for specific programming within the cascade mode. The bits in ICW3 indicate which interrupt request inputs have a Slave cascaded to them. This will subsequently affect the interrupt vector generation during the interrupt acknowledge cycles as described previously.

ICW4

The ICW4 is accepted only if it was selected in ICW1. This command word register serves two functions:

- To select either the Automatic EOI mode or software EOI mode;
- To select if the Special Nested mode is to be used in conjunction with the cascade mode.

4.5.2 OPERATION CONTROL WORDS (OCW)

Once initialized by the ICW's, the interrupt banks will be operating in the Fully Nested Mode by default and they are ready to accept interrupt requests. However, the operations of each interrupt bank can be further controlled or modified by the use of OCW's. Three OCW's are available for programming various modes and commands. Note that all OCW's are 8-bit write-only registers.

The modes and operations controlled by the OCW's are:

- Fully Nested Mode;
- Rotating Priority Mode;
- Special Mask Mode;
- Poll Mode;
- EOI Commands;
- Read Status Commands.

OCW1

OCW1 is used solely for masking operations. It provides a direct link to the Internal Mask Register (IMR). The 80376 can write to this OCW register to enable or disable the interrupt inputs. Reading the pre-programmed mask can be done via the Interrupt Mask Register which will be discussed shortly.

OCW2

OCW2 is used to select End-Of-Interrupt, Automatic Priority Rotation, and Specific Priority Rotation operations. Associated commands and modes of these operations are selected using the different combinations of bits in OCW2.

Specifically, the OCW2 is used to:

- Designate an interrupt level (0–7) to be used to reset a specific ISR bit or to set a specific priority. This function can be enabled or disabled;
- Select which software EOI command (if any) is to be executed (i.e. Non-Specific or Specific EOI);
- Enable one of the priority rotation operations (i.e. Rotate On Non-Specific EOI, Rotate On Automatic EOI, or Rotate On Specific EOI).

OCW3

There are three main categories of operation that OCW3 controls. They are summarized as follows:

- To select and execute the Read Status Register Commands, either reading the Interrupt Request Register (IRR) or the In-Service Register (ISR);
- To issue the Poll Command. The Poll Command will override a Read Register Command if both functions are enabled simultaneously;
- To set or reset the Special Mask Mode.

4.5.3 POLL/INTERRUPT REQUEST/IN-SERVICE STATUS REGISTER

As the name implies, this 8-bit read-only register has multiple functions. Depending on the command issued in the OCW3, the content of this register reflects the result of the command executed. For a Poll Command, the register read contains the binary code of the highest priority level requesting service (if any). For a Read IRR Command, the register content will show the current pending interrupt request(s). Finally, for a Read ISR Command, this register will specify all interrupt levels which are being serviced.

4.5.4 INTERRUPT MASK REGISTER (IMR)

This is a read-only 8-bit register which, when read, will specify all interrupt levels within the same bank that are masked.

4.5.5 VECTOR REGISTERS (VR)

Each interrupt request input has an 8-bit read/write programmable vector register associated with it. The registers should be programmed to contain the interrupt vector for the corresponding request. The contents of the Vector Register will be placed on the Data Bus during the INTA cycles as described previously.

4.6 Programming

Programming the 82370 PIC is accomplished by using two types of command words: ICW's and OCW's. All modes and commands explained in the previous sections are programmable using the ICW's and OCW's. The ICW's are issued from the 80376 in a sequential format and are used to setup the banks in the 82370 PIC in an initial state of operation. The OCW's are issued as needed to vary and control the 82370 PIC's operations.

Both ICW's and OCW's are sent by the 80376 to the interrupt banks via the Data Bus. Each bank distinguishes between the different ICW's and OCW's by the I/O address map, the sequence they are issued (ICW's only), and by some dedicated bits among the ICW's and OCW's.

An example of programming the 82370 interrupt controllers is given in Appendix C (Programming the 82370 Interrupt Controllers).

All three interrupt banks are programmed in a similar way. Therefore, only a single bank will be described in the following sections.

4.6.1 INITIALIZATION (ICW)

Before normal operation can begin, each bank must be initialized by programming a sequence of two to four bytes written into the ICW's.

Figure 4-6 shows the initialization flow for an interrupt bank. Both ICW1 and ICW2 must be issued for any form of operation. However, ICW3 and ICW4 are used only if designated in ICW1. Once initialized, if any programming changes within the ICW's are to be made, the entire ICW sequence must be reprogrammed, not just an individual ICW.

Note that although the ICW2's in the 82370 PIC do not effect the Bank's operation, they still must be programmed in order to preserve the compatibility with the 82C59A. The contents programmed are not relevant to the overall operations of the interrupt banks. Also, whenever one of the three ICW2's is programmed, an interrupt level 1.5 in Bank A will be generated. This interrupt request will be cleared upon reading of the ICW2 registers. Since the three ICW2's share the same interrupt level and the system may not know the origin of the interrupt, all three ICW2's must be read.

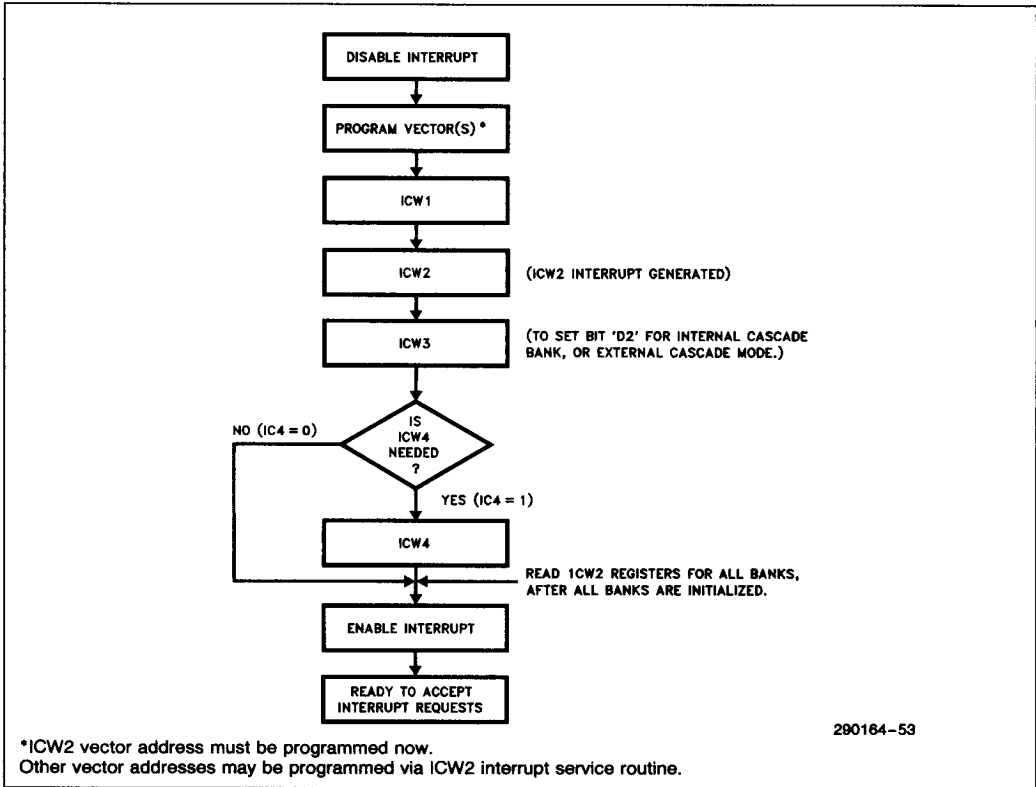

Figure 4-6. Initialization Sequence

Certain internal setup conditions occur automatically within the interrupt bank after the first ICW (ICW1) has been issued. These are:

- The edge sensitive circuit is reset, which means that following initialization, an interrupt request input must make a HIGH-to-LOW transition to generate an interrupt;
- The Interrupt Mask Register (IMR) is cleared; that is, all interrupt inputs are enabled;
- IRQ7 input of each bank is assigned priority 7 (lowest);
- Special Mask Mode is cleared and Status Read is set to IRR;
- If no ICW4 is needed, then no Automatic-EOI is selected.

4.6.2 VECTOR REGISTERS (VR)

Each interrupt request input has a separate Vector Register. These Vector Registers are used to store the pre-programmed vector number corresponding to their interrupt sources. In order to guarantee proper interrupt handling, all Vector Registers must be programmed with the predefined vector numbers. Since an interrupt request will be generated whenever an ICW2 is written during the initialization sequence, it is important that the Vector Register of IRQ1.5 in Bank A should be initialized and the interrupt service routine of this vector is set up before the ICW's are written.

4.6.3 OPERATION CONTROL WORDS (OCW)

After the ICW's are programmed, the operations of each interrupt controller bank can be changed by writing into the OCW's as explained before. There is no special programming sequence required for the OCW's. Any OCW may be written at any time in order to change the mode of or to perform certain operations on the interrupt banks.

4.6.3.1 Read Status and Poll Commands (OCW3)

Since the reading of IRR and ISR status as well as the result of a Poll Command are available on the same read-only Status Register, a special Read Status/Poll Command must be issued before the Poll/Interrupt Request/In-Service Status Register is read. This command can be specified by writing the required control word into OCW3. As mentioned earlier, if both the Poll Command and the Status Read Command are enabled simultaneously, the Poll Command will override the Status Read. That is, after the command execution, the Status Register will contain the result of the Poll Command.

Note that for reading IRR and ISR, there is no need to issue a Read Status Command to the OCW3 every time the IRR or ISR is to be read. Once a Read Status Command is received by the interrupt bank, it "remembers" which register is selected. However, this is not true when the Poll Command is used.

In the Poll Command, after the OCW3 is written, the 82370 PIC treats the next read to the Status Register as an interrupt acknowledge. This will set the appropriate IS bit if there is a request and read the priority level. Interrupt Request input status remains unchanged from the Poll Command to the Status Read.

In addition to the above read commands, the Interrupt Mask Register (IMR) can also be read. When read, this register reflects the contents of the pre-programmed OCW1 which contains information on which interrupt request(s) is(are) currently disabled.

1

4.7 Register Bit Definition

INITIALIZATION COMMAND WORD 1 (ICW1)

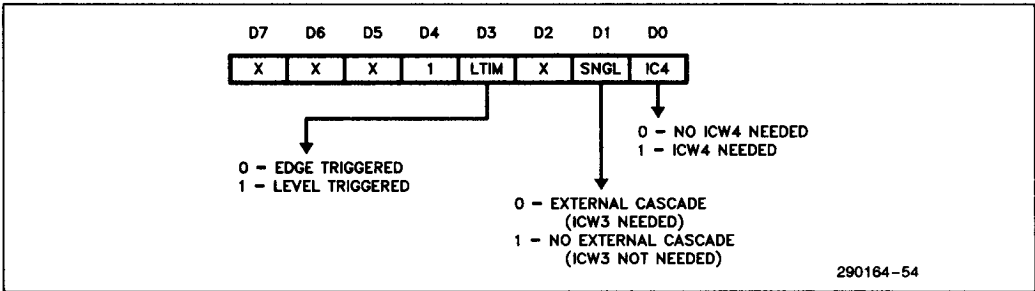

INITIALIZATION COMMAND WORD 2 (ICW2)

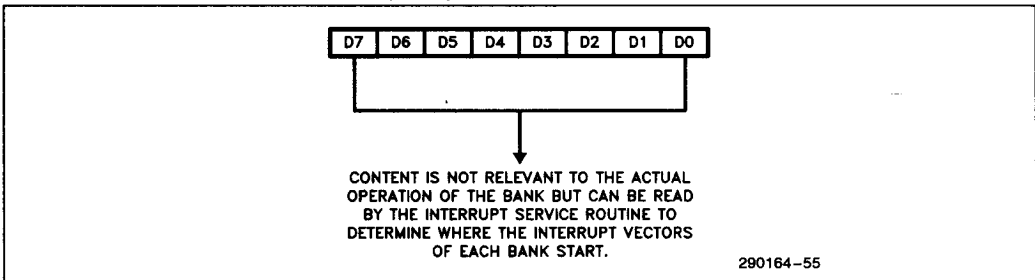

INITIALIZATION COMMAND WORD 3 (ICW3)

ICW3 for Bank A:

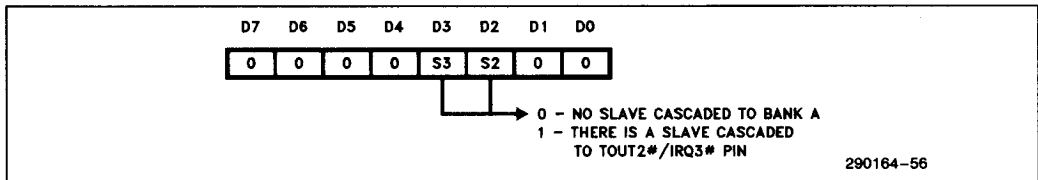

ICW3 for Bank B:

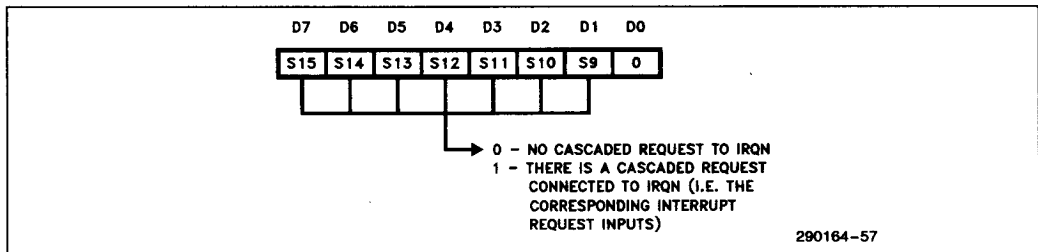

ICW3 for Bank C:

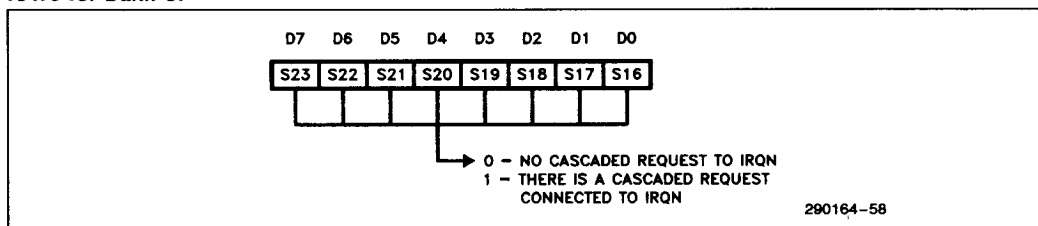

INITIALIZATION COMMAND WORD 4 (ICW4)

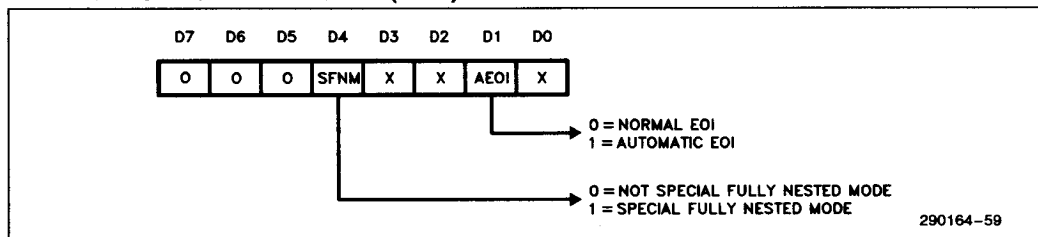

OPERATION CONTROL WORD 1 (OCW1)

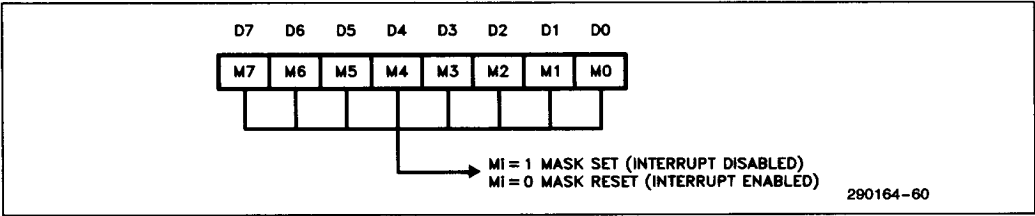

OPERATION CONTROL WORD 2 (OCW2)

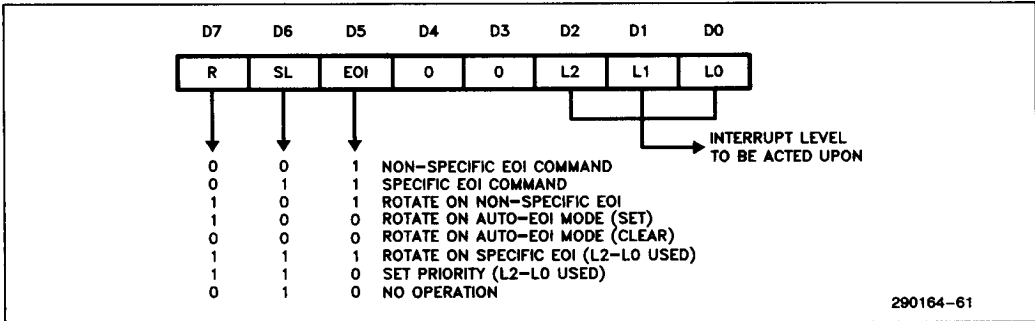

1

OPERATION CONTROL WORD 3 (OCW3)

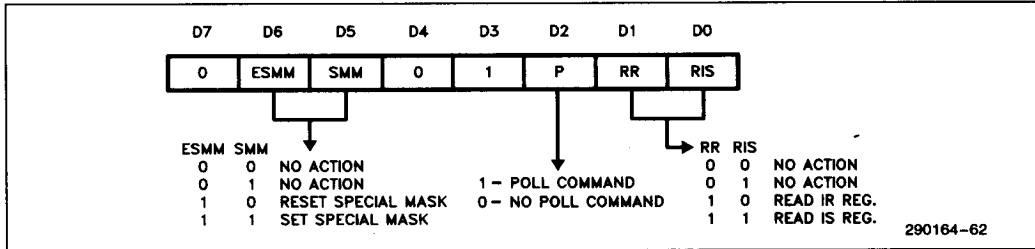

ESMM — Enable Special Mask Mode. When this bit is set to 1, it enables the SMM bit to set or reset the Special Mask Mode. When this bit is set to 0, SMM bit becomes don't care.

SMM — Special Mask Mode. If ESMM = 1 and SMM = 1, the interrupt controller bank will enter Special Mask Mode. If ESMM = 1 and SMM = 0, the bank will revert to normal mask mode. When ESMM = 0, SMM has no effect.

POLL/INTERRUPT REQUEST/IN-SERVICE STATUS REGISTER

Poll Command Status

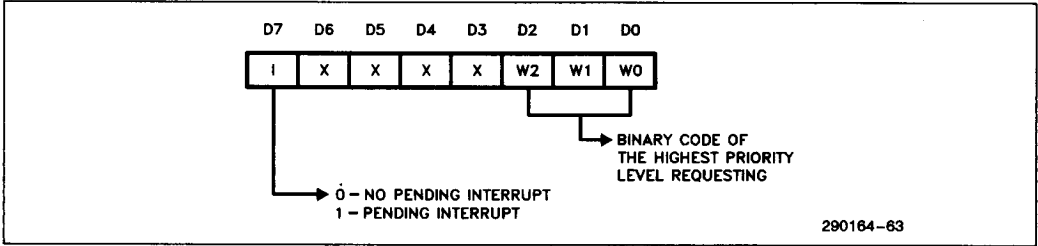

Interrupt Request Status

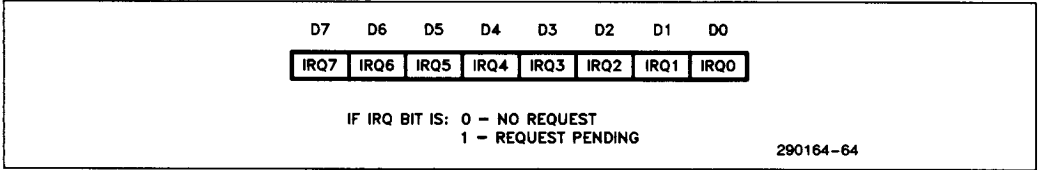

NOTE:

Although all Interrupt Request inputs are active LOW, the internal logical will invert the state of the pins so that when there is a pending interrupt request at the input, the corresponding IRQ bit will be set to HIGH in the Interrupt Request Status register.

In-Service Status

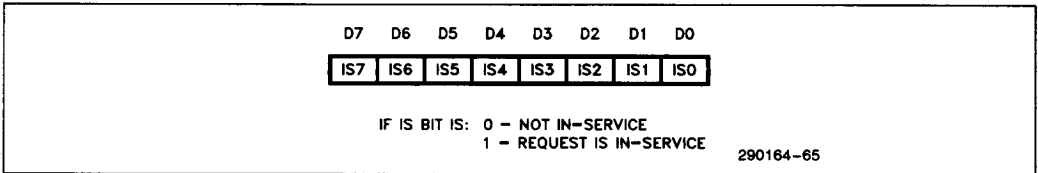

VECTOR REGISTER (VR)

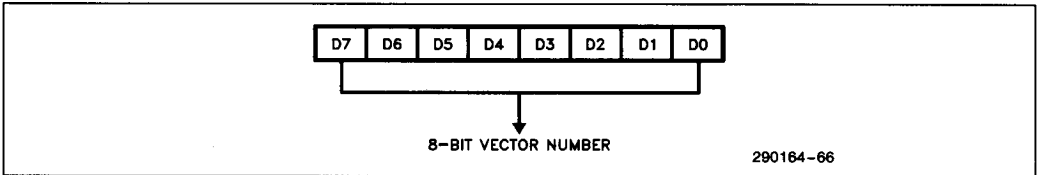

Table 4-4. Register Operational Summary

| Operational Description | Command Words | Bits |
|------------------------------------|---------------|----------------|
| Fully Nested Mode | OCW-Default | |
| Non-specific EOI Command | OCW2 | EOI |
| Specific EOI Command | OCW2 | SL, EOI, L0-L2 |
| Automatic EOI Mode | ICW1, ICW4 | IC4, AEOI |
| Rotate On Non-Specific EOI Command | OCW2 | EOI |
| Rotate On Automatic EOI Mode | OCW2 | R, SL, EOI |
| Set Priority Command | OCW2 | L0-L2 |
| Rotate On Specific EOI Command | OCW2 | R, SL, EOI |
| Interrupt Mask Register | OCW1 | M0-M7 |
| Special Mask Mode | OCW3 | ESMM, SMM |
| Level Triggered Mode | ICW1 | LTIM |
| Edge Triggered Mode | ICW1 | LTIM |
| Read Register Command, IRR | OCW3 | RR, RIS |
| Read Register Command, ISR | OCW3 | RR, RIS |
| Read IMR | IMR | M0-M7 |
| Poll Command | OCW3 | P |
| Special Fully Nested Mode | ICW1, ICW4 | IC4, SFNM |

1

4.8 Register Operational Summary

For ease of reference, Table 4-4 gives a summary of the different operating modes and commands with their corresponding registers.

5.0 PROGRAMMABLE INTERVAL TIMER

5.1 Functional Description

The 82370 contains four independently Programmable Interval Timers: Timer 0-3. All four timers are functionally compatible to the Intel 82C54. The first three timers (Timer 0-2) have specific functions. The fourth timer, Timer 3, is a general purpose timer. Table 5-1 depicts the functions of each timer. A brief description of each timer's function follows.

Table 5-1. Programmable Interval Timer Functions

| Timer | Output | Function |
|-------|-------------|--------------------------------|
| 0 | IRQ8 | Event Based IRQ8 Generator |
| 1 | TOUT1/REF# | Gen. Purpose/DRAM Refresh Req. |
| 2 | TOUT2/IRQ3# | Gen. Purpose/Speaker Out/IRQ3# |
| 3 | TOUT3# | Gen. Purpose/IRQ0 Generator |

TIMER 0—Event Based Interrupt Request 8 Generator

Timer 0 is intended to be used as an Event Counter. The output of this timer will generate an Interrupt Request 8 (IRQ8) upon a rising edge of the timer output (TOUT0). Normally, this timer is used to implement a time-of-day clock or system tick. The Timer 0 output is not available as an external signal.

TIMER 1—General Purpose/DRAM Refresh Request

The output of Timer 1, TOUT1, can be used as a general purpose timer or as a DRAM Refresh Request signal. The rising edge of this output creates a DRAM refresh request to the 82370 DRAM Refresh Controller. Upon reset, the Refresh Request function is disabled, and the output pin is the Timer 1 output.

TIMER 2—General Purpose/Speaker Out/IRQ3#

The Timer 2 output, TOUT2#, could be used to support tone generation to an external speaker. This pin is a bidirectional signal. When used as an input, a logic LOW asserted at this pin will generate an Interrupt Request 3 (IRQ3#) (see Programmable Interrupt Controller).

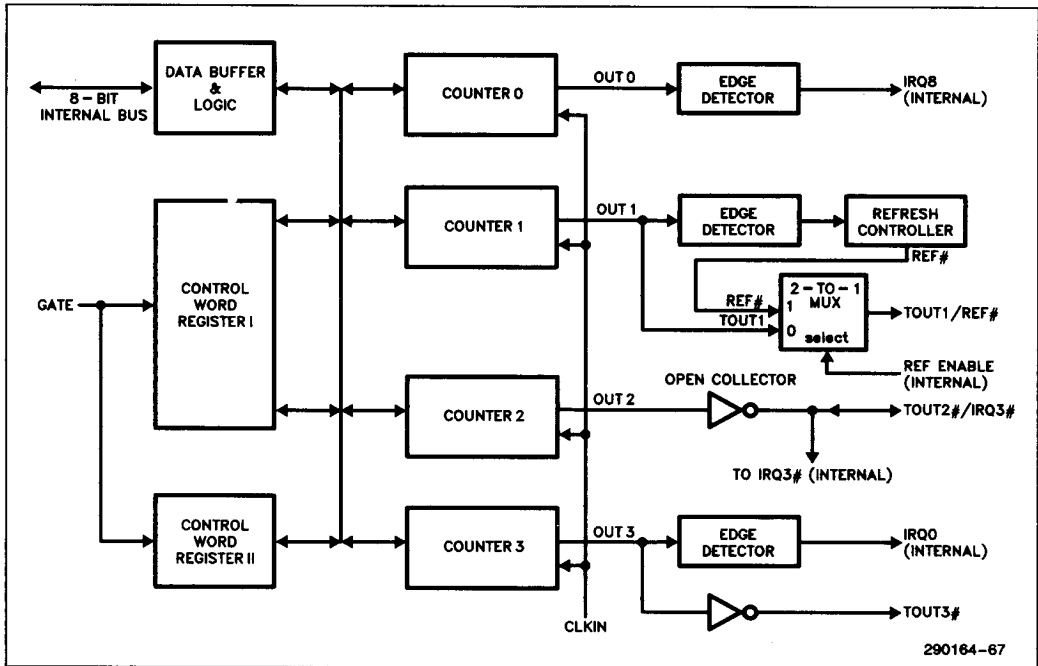

Figure 5-1. Block Diagram of Programmable Interval Timer

TIMER 3—General Purpose/Interrupt Request 0 Generator

The output of Timer 3 is fed to an edge detector and generates an Interrupt Request 0 (IRQ0) in the 82370. The inverted output of this timer (TOUT3#) is also available as an external signal for general purpose use.

5.1.1 INTERNAL ARCHITECTURE

The functional block diagram of the Programmable Interval Timer section is shown in Figure 5-1. Following is a description of each block.

DATA BUFFER & READ/WRITE LOGIC

This part of the Programmable Interval Timer is used to interface the four timers to the 82370 internal bus. The Data Buffer is for transferring commands and data between the 8-bit internal bus and the timers.

The Read/Write Logic accepts inputs from the internal bus and generates signals to control other functional blocks within the timer section.

CONTROL WORD REGISTERS I & II

The Control Word Registers are write-only registers. They are used to control the operating modes of the timers. Control Word Register I controls Timers 0, 1 and 2, and Control Word Register II controls Timer 3. Detailed description of the Control Word Registers will be included in the Register Set Overview section.

COUNTER 0, COUNTER 1, COUNTER 2, COUNTER 3

Counters 0, 1, 2, and 3 are the major parts of Timers 0, 1, 2, and 3, respectively. These four functional blocks are identical in operation, so only a single counter will be described. The internal block diagram of one counter is shown in Figure 5-2.

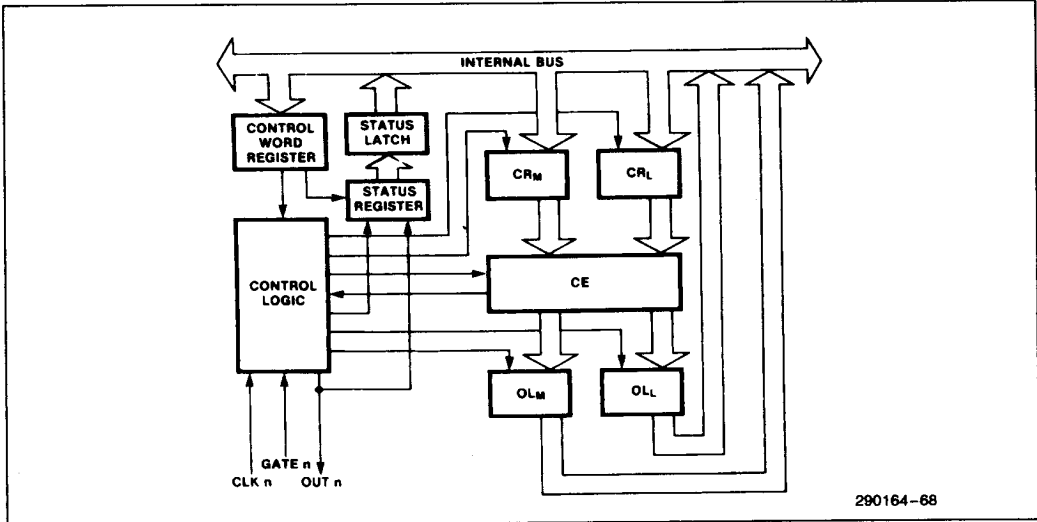

Figure 5-2. Internal Block Diagram of a Counter

The four counters share a common clock input (CLKIN), but otherwise are fully independent. Each counter is programmable to operate in a different mode.

Although the Control Word Register is shown in the figure, it is not part of the counter itself. Its programmed contents are used to control the operations of the counters.

The Status Register, when latched, contains the current contents of the Control Word Register and status of the output and Null Count Flag (see Read Back Command).

The Counting Element (CE) is the actual counter. It is a 16-bit presettable synchronous down counter.

The Output Latches (OL) contain two 8-bit latches (OLM and OLL). Normally, these latches "follow" the content of the CE. OLM contains the most significant byte of the counter and OLL contains the least significant byte. If the Counter Latch Command is sent to the counter, OL will latch the present count until read by the 80376 and then return to follow the CE. One latch at a time is enabled by the timer's Control Logic to drive the internal bus. This is how the 16-bit Counter communicates over the 8-bit internal bus. Note that CE cannot be read. Whenever the count is read, it is one of the OL's that is being read.

When a new count is written into the counter, the value will be stored in the Count Registers (CR), and transferred to CE. The transferring of the contents from CR's to CE is defined as "loading" of the counter. The Count Register contains two 8-bit registers: CRM (which contains the most significant byte) and CRL (which contains the least significant byte). Similar to the OL's, the Control Logic allows one register at a time to be loaded from the 8-bit internal bus. However, both bytes are transferred from the CR's to the CE simultaneously. Both CR's are cleared when the Counter is programmed. This way, if the Counter has been programmed for one byte count (either the most significant or the least significant byte only), the other byte will be zero. Note that CE cannot be written into directly. Whenever a count is written, it is the CR that is being written.

As shown in the diagram, the Control Logic consists of three signals: CLKIN, GATE, and OUT. CLKIN and GATE will be discussed in detail in the section that follows. OUT is the internal output of the counter. The external outputs of some timers (TOUT) are the inverted version of OUT (see TOUT1, TOUT2#, TOUT3#). The state of OUT depends on the mode of operation of the timer.

5.2 Interface Signals

5.2.1 CLKIN

CLKIN is an input signal used by all four timers for internal timing reference. This signal can be independent of the 82370 system clock, CLK2. In the following discussion, each "CLK Pulse" is defined as the time period between a rising edge and a falling edge, in that order, of CLKIN.

During the rising edge of CLKIN, the state of GATE is sampled. All new counts are loaded and counters are decremented on the falling edge of CLKIN.

5.2.2 TOUT1, TOUT2#, TOUT3#

TOUT1, TOUT2# and TOUT3# are the external output signals of Timer 1, Timer 2 and Timer 3, respectively. TOUT2# and TOUT3# are the inverted signals of their respective counter outputs, OUT. There is no external output for Timer 0.

If Timer 2 is to be used as a tone generator of a speaker, external buffering must be used to provide sufficient drive capability.

The Outputs of Timer 2 and 3 are dual function pins. The output pin of Timer 2 (TOUT2#/IRQ3#), which is a bidirectional open-collector signal, can also be used as interrupt request input. When the interrupt function is enabled (through the Programmable Interrupt Controller), a LOW on this input will generate an Interrupt Request 3# to the 82370 Programmable Interrupt Controller. This pin has a weak internal pull-up resistor. To use the IRQ3# function, Timer 2 should be programmed so that OUT2 is LOW. Additionally, OUT3 of Timer 3 is connected to an edge detector which will generate an Interrupt Request 0 (IRQ0) to the 82370 after the rising edge of OUT3 (see Figure 5-1).

5.2.3 GATE

GATE is not an externally controllable signal. Rather, it can be software controlled with the Internal Control Port. The state of GATE is always sampled on the rising edge of CLKIN. Depending on the mode of operation, GATE is used to enable/disable counting or trigger the start of an operation.

For Timer 0 and 1, GATE is always enabled (HIGH). For Timer 2 and 3, GATE is connected to Bit 0 and 6, respectively, of an Internal Control Port (at address 61H) of the 82370. After a hardware reset, the state of GATE of Timer 2 and 3 is disabled (LOW).

5.3 Modes of Operation

Each timer can be independently programmed to operate in one of six different modes. Timers are programmed by writing a Control Word into the Control Word Register followed by an Initial Count (see Programming).

The following are defined for use in describing the different modes of operation.

CLK Pulse—A rising edge, then a falling edge, in that order, of CLKIN.

Trigger—A rising edge of a timer's GATE input.

Timer/Counter Loading—The transfer of a count from Count Register (CR) to Count Element (CE).

5.3.1 MODE 0—INTERRUPT ON TERMINAL COUNT

Mode 0 is typically used for event counting. After the Control Word is written, OUT is initially LOW, and will remain LOW until the counter reaches zero. OUT then goes HIGH and remains HIGH until a new count or a new Mode 0 Control Word is written into the counter.

In this mode, GATE=HIGH enables counting; GATE = LOW disables counting. However, GATE has no effect on OUT.

After the Control Word and initial count are written to a timer, the initial count will be loaded on the next CLK pulse. This CLK pulse does not decrement the count, so for an initial count of N, OUT does not go HIGH until N + 1 CLK pulses after the initial count is written.

If a new count is written to the timer, it will be loaded on the next CLK pulse and counting will continue from the new count. If a two-byte count is written, the following happens:

1. Writing the first byte disables counting, OUT is set LOW immediately (i.e. no CLK pulse required).
2. Writing the second byte allows the new count to be loaded on the next CLK pulse.

This allows the counting sequence to be synchronized by software. Again, OUT does not go HIGH until N + 1 CLK pulses after the new count of N is written.

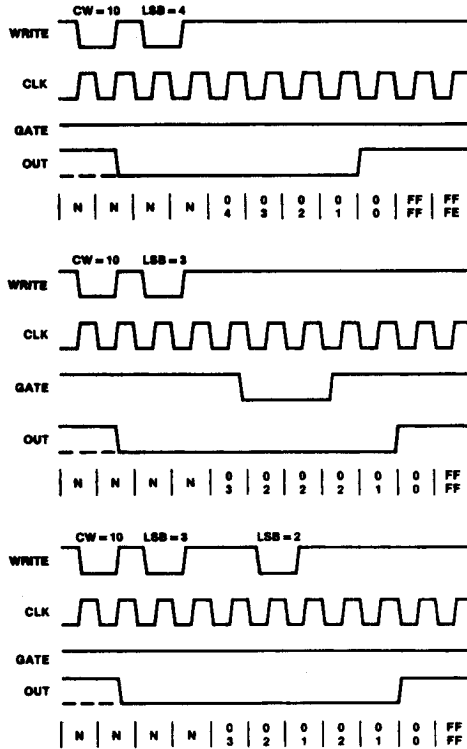

290164-69

NOTES:

The following conventions apply to all mode timing diagrams.

1. Counters are programmed for binary (not BCD) counting and for reading/writing least significant byte (LSB) only.
2. The counter is always selected (CS# always low).
3. CW stands for "Control Word"; CW = 10 means a control word of 10, Hex is written to the counter.
4. LSB stands for "Least significant byte" of count.
5. Numbers below diagrams are count values.

The lower number is the least significant byte.

The upper number is the most significant byte. Since the counter is programmed to read/write LSB only, the most significant byte cannot be read.

N stands for an undefined count.

Vertical lines show transitions between count values.

Figure 5-3. Mode 0

If an initial count is written while GATE is LOW, the counter will be loaded on the next CLK pulse. When GATE goes HIGH, OUT will go HIGH N CLK pulses later; no CLK pulse is needed to load the counter as this has already been done.

5.3.2 MODE 1-GATE RETRIGGERABLE ONE-SHOT

In this mode, OUT will be initially HIGH. OUT will go LOW on the CLK pulse following a trigger to start the

one-shot operation. The OUT signal will then remain LOW until the timer reaches zero. At this point, OUT will stay HIGH until the next trigger comes in. Since the state of GATE signals of Timer 0 and 1 are internally set to HIGH.

After writing the Control Word and initial count, the timer is considered "armed". A trigger results in loading the timer and setting OUT LOW on the next CLK pulse. Therefore, an initial count of N will result in a one-shot pulse width of N CLK cycles. Note

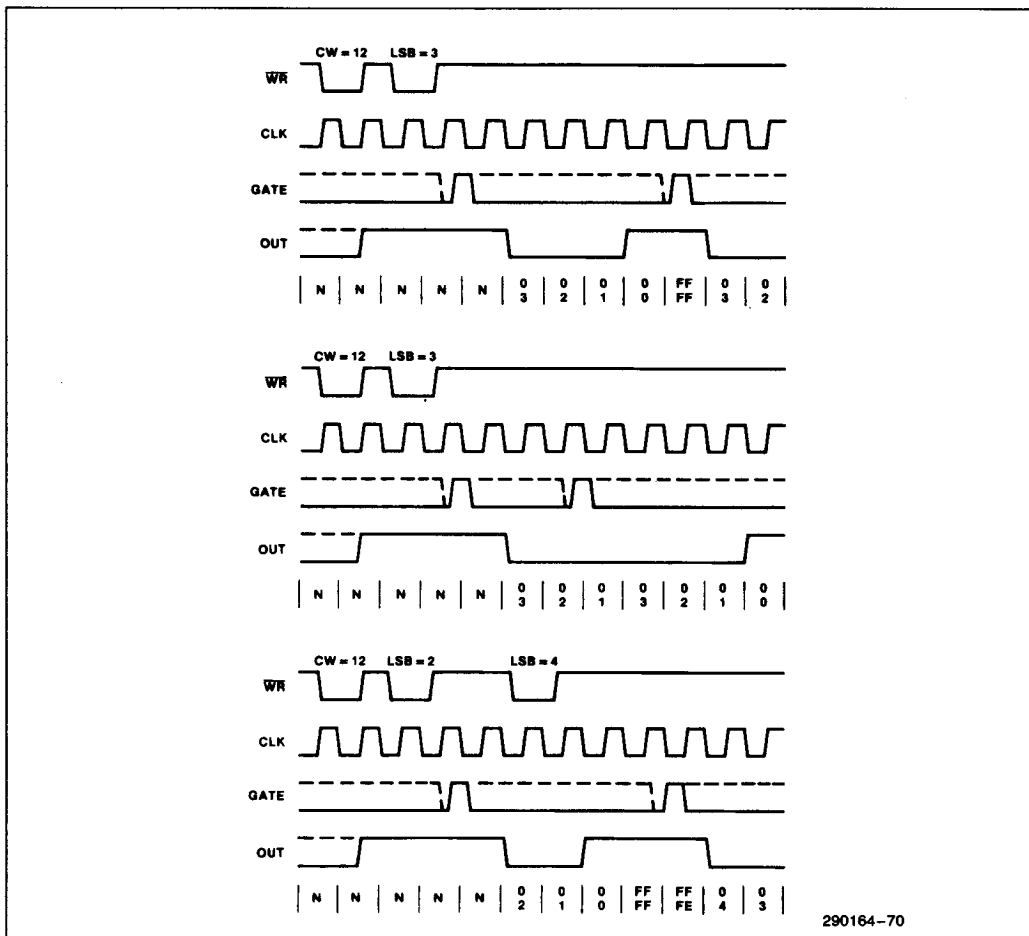

290164-70

Figure 5-4. Mode 1

that this one-shot operation is retriggerable; i.e. OUT will remain LOW for N CLK pulses after every trigger. The one-shot operation can be repeated without re-writing the same count into the timer.

If a new count is written to the timer during a one-shot operation, the current one-shot pulse width will not be affected until the timer is retriggered. This is because loading of the new count to CE will occur only when the one-shot is triggered.

5.3.3 MODE 2-RATE GENERATOR

This mode is a divide-by-N counter. It is typically used to generate a Real Time Clock interrupt. OUT will initially be HIGH. When the initial count has dec-

remented to 1, OUT goes LOW for one CLK pulse, then OUT goes HIGH again. Then the timer reloads the initial count and the process is repeated. In other words, this mode is periodic since the same sequence is repeated itself indefinitely. For an initial count of N, the sequence repeats every N CLK cycles.

Similar to Mode 0, GATE=HIGH enables counting, where GATE=LOW disables counting. If GATE goes LOW during an output pulse (LOW), OUT is set HIGH immediately. A trigger (rising edge on GATE) will reload the timer with the initial count on the next CLK pulse. Then, OUT will go LOW (for one CLK pulse) N CLK pulses after the new trigger. Thus, GATE can be used to synchronize the timer.

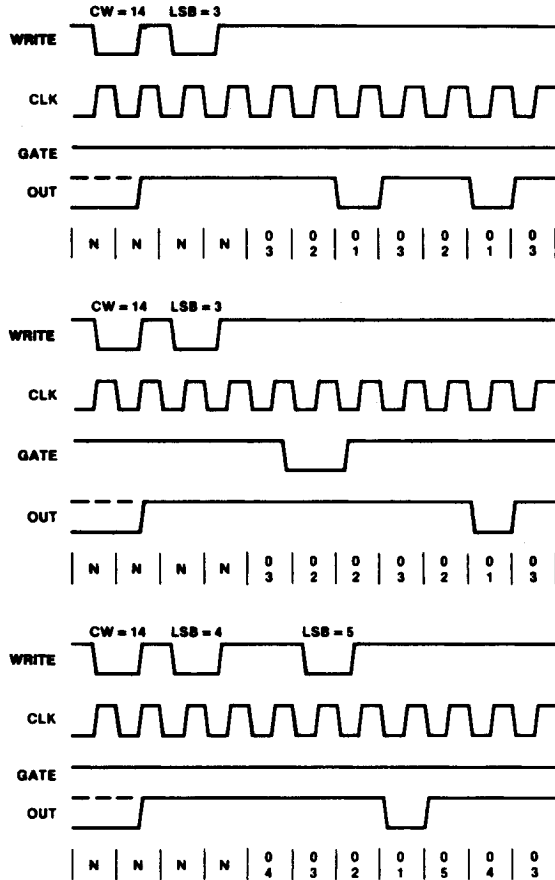

290164-71

NOTE:

A GATE transition should not occur one clock prior to terminal count.

Figure 5-5. Mode 2

After writing a Control Word and initial count, the timer will be loaded on the next CLK pulse. OUT goes LOW (for one CLK pulse) N CLK pulses after the initial count is written. This is another way the timer may be synchronized by software.

Writing a new count while counting does not affect the current counting sequence because the new count will not be loaded until the end of the current counting cycle. If a trigger is received after writing a

new count but before the end of the current period, the timer will be loaded with the new count on the next CLK pulse after the trigger, and counting will continue with the new count.

5.3.4 MODE 3-SQUARE WAVE GENERATOR

Mode 3 is typically used for Baud Rate generation. Functionally, this mode is similar to Mode 2 except

for the duty cycle of OUT. In this mode, OUT will be initially HIGH. When half of the initial count has expired, OUT goes low for the remainder of the count. The counting sequence will be repeated, thus this mode is also periodic. Note that an initial count of N results in a square wave with a period of N CLK pulses.

The GATE input can be used to synchronize the timer. GATE = HIGH enables counting; GATE = LOW disables counting. If GATE goes LOW while OUT is LOW, OUT is set HIGH immediately (i.e. no CLK pulse is required). A trigger reloads the timer with the initial count on the next CLK pulse.

After writing a Control Word and initial count, the timer will be loaded on the next CLK pulse. This allows the timer to be synchronized by software.

Writing a new count while counting does not affect the current counting sequence. If a trigger is received after writing a new count but before the end of the current half-cycle of the square wave, the timer will be loaded with the new count on the next CLK pulse and counting will continue from the new count. Otherwise, the new count will be loaded at the end of the current half-cycle.

There is a slight difference in operation depending on whether the initial count is EVEN or ODD. The following description is to show exactly how this mode is implemented.

EVEN COUNTS:

OUT is initially HIGH. The initial count is loaded on one CLK pulse and is decremented by two on succeeding CLK pulses. When the count expires (decremented to 2), OUT changes to LOW and the timer is reloaded with the initial count. The above process is repeated indefinitely.

ODD COUNTS:

OUT is initially HIGH. The initial count minus one (which is an even number) is loaded on one CLK pulse and is decremented by two on succeeding CLK pulses. One CLK pulse after the count expires (decremented to 2), OUT goes LOW and the timer is loaded with the initial count minus one again. Succeeding CLK pulses decrement the count by two. When the count expires, OUT goes HIGH immediately and the timer is reloaded with the initial count minus one. The above process is repeated indefinitely. So for ODD counts, OUT will HIGH for $(N+1)/2$ counts and LOW for $(N-1)/2$ counts.



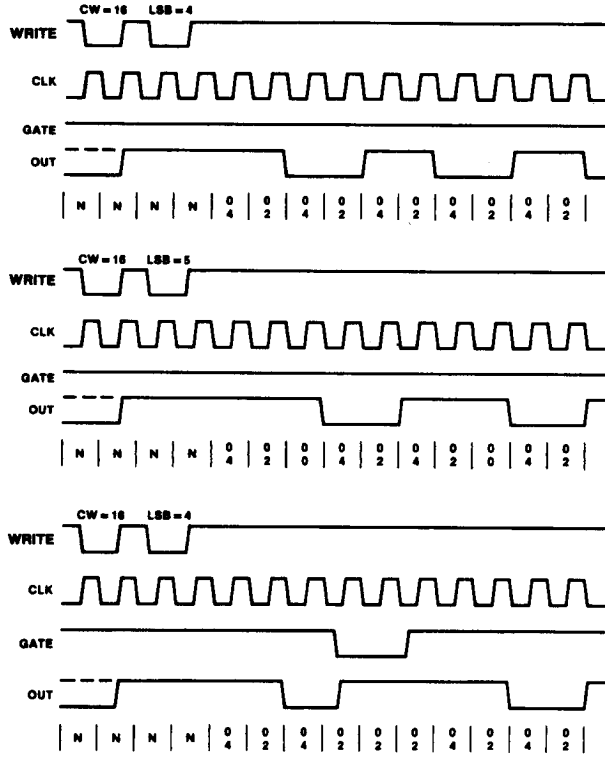

290164-72

NOTE:
A GATE transition should not occur one clock prior to terminal count.

Figure 5-6. Mode 3

5.3.5 MODE 4-INITIAL COUNT TRIGGERED STROBE

This mode allows a strobe pulse to be generated by writing an initial count to the timer. Initially, OUT will be HIGH. When a new initial count is written into the timer, the counting sequence will begin. When the initial count expires (decremented to 1), OUT will go LOW for one CLK pulse and then go HIGH again.

Again, GATE=HIGH enables counting while GATE = LOW disables counting. GATE has no effect on OUT.

After writing the Control Word and initial count, the timer will be loaded on the next CLK pulse. This CLK pulse does not decrement the count, so for an initial count of N, OUT does not strobe LOW until N + 1 CLK pulses after initial count is written.

If a new count is written during counting, it will be loaded in the next CLK pulse and counting will continue from the new count.

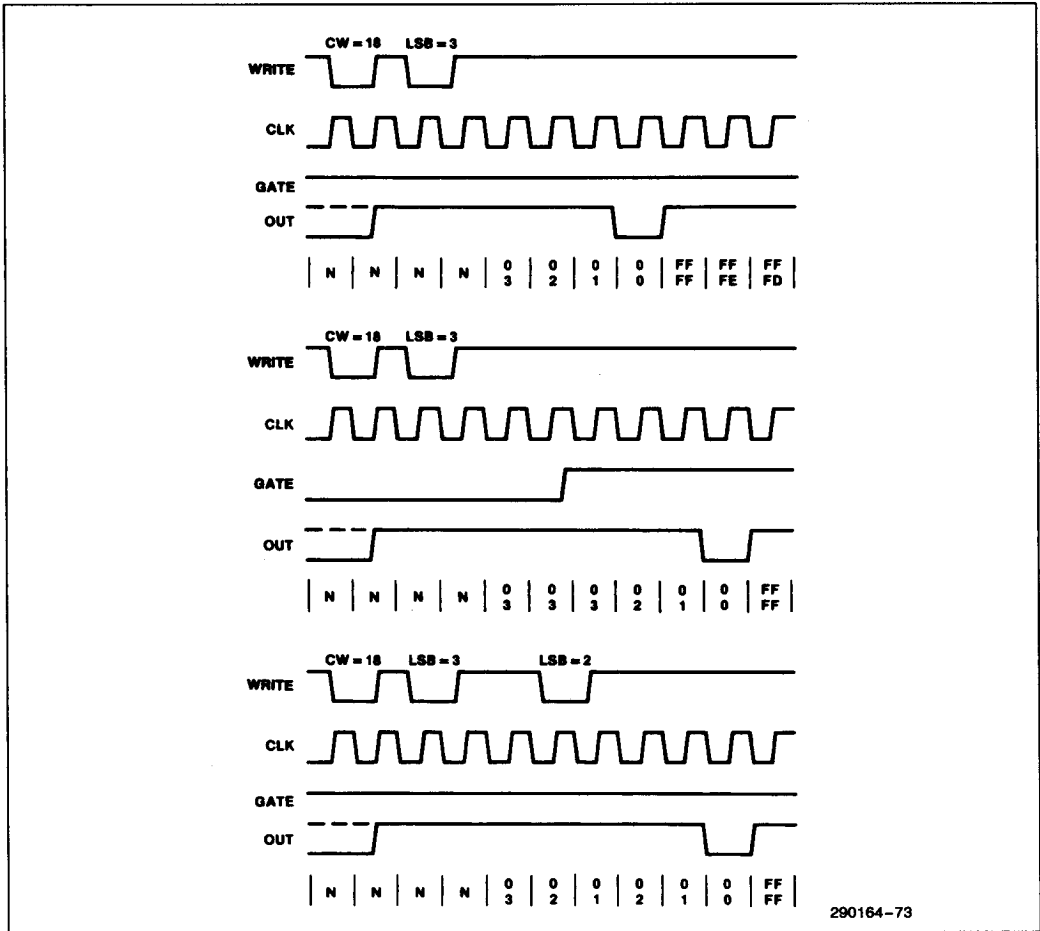

Figure 5-7. Mode 4

290164-73

If a two-byte count is written, the following will occur:

1. Writing the first byte has no effect on counting.
2. Writing the second byte allows the new count to be loaded on the next CLK pulse.

OUT will strobe LOW N+1 CLK pulses after the new count of N is written. Therefore, when the strobe pulse will occur after a trigger depends on the value of the initial count loaded.

by writing an initial count. Initially, OUT will be HIGH. Counting is triggered by a rising edge of GATE. When the initial count has expired (decremented to 1), OUT will go LOW for one CLK pulse and then go HIGH again.

After loading the Control Word and initial count, the Count Element will not be loaded until the CLK pulse after a trigger. This CLK pulse does not decrement the count. Therefore, for an initial count of N, OUT does not strobe LOW until N+1 CLK pulses after a trigger.

5.3.6 MODE 5—GATE RETRIGGERABLE STROBE

Mode 5 is very similar to Mode 4 except the count sequence is triggered by the gate signal instead of

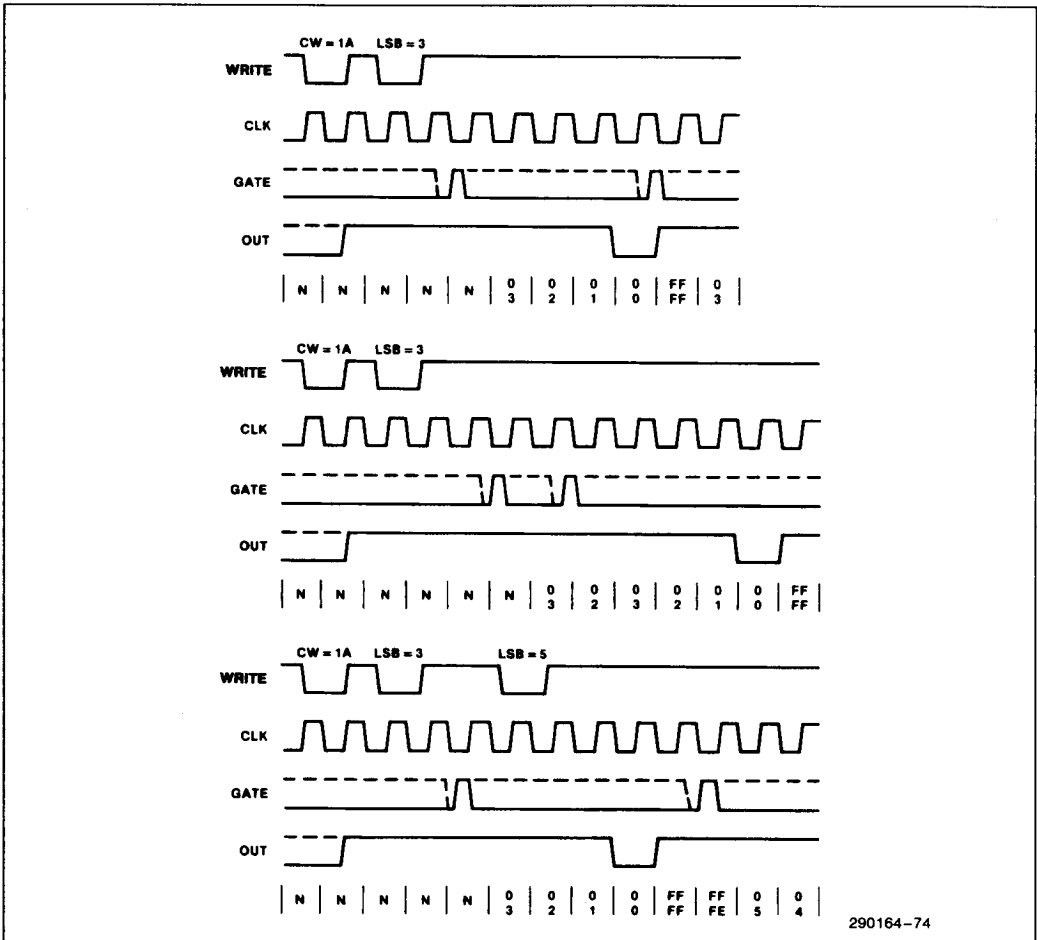

Figure 5-8. Mode 5

The counting sequence is retriggerable. Every trigger will result in the timer being loaded with the initial count on the next CLK pulse.

If the new count is written during counting, the current counting sequence will not be affected. If a trigger occurs after the new count is written but before the current count expires, the timer will be loaded with the new count on the next CLK pulse and a new count sequence will start from there.

5.3.7 OPERATION COMMON TO ALL MODES

5.3.7.1 GATE

The GATE input is always sampled on the rising edge of CLKIN. In Modes 0, 2, 3 and 4, the GATE input is level sensitive. The logic level is sampled on the rising edge of CLKIN. In Modes 1, 2, 3 and 5, the GATE input is rising edge sensitive. In these modes,

Summary of Gate Operations

| Mode | GATE LOW or Going LOW | GATE Rising | HIGH |
|------|---|---|--------------|
| 0 | Disable count | No Effect | Enable count |
| 1 | No Effect | 1. Initiate count 2. Reset output after next clock | No Effect |
| 2 | 1. Disable count 2. Sets output HIGH immediately | Initiate count | Enable count |
| 3 | 1. Disable count 2. Sets output HIGH immediately | Initiate count | Enable count |
| 4 | Disable count | No Effect | Enable count |
| 5 | No Effect | Initiate count | No Effect |

a rising edge of GATE (trigger) sets an edge sensitive flip-flop in the timer. The flip-flop is reset immediately after it is sampled. This way, a trigger will be detected no matter when it occurs; i.e. a HIGH logic level does not have to be maintained until the next rising edge of CLKIN. Note that in Modes 2 and 3, the GATE input is both edge and level sensitive.

5.3.7.2 Counter

New counts are loaded and counters are decremented on the falling edge of CLKIN. The largest possible initial count is 0. This is equivalent to 2^{16} for binary counting and 10^4 for BCD counting.

Note that the counter does not stop when it reaches zero. In Modes 0, 1, 4 and 5, the counter 'wraps around' to the highest count: either FFFF Hex for binary counting or 9999 for BCD counting, and continues counting. Modes 2 and 3 are periodic. The counter reloads itself with the initial count and continues counting from there.

The minimum and maximum initial count in each counter depends on the mode of operation. They are summarized below.

| Mode | Min | Max |
|------|-----|-----|
| 0 | 1 | 0 |
| 1 | 1 | 0 |
| 2 | 2 | 0 |
| 3 | 2 | 0 |
| 4 | 1 | 0 |
| 5 | 1 | 0 |

5.4 Register Set Overview

The Programmable Interval Timer module of the 82370 contains a set of six registers. The port address map of these registers is shown in Table 5-2.

Table 5-2. Timer Register Port Address Map

| Port Address | Description |
|--------------|--|
| 40H | Counter 0 Register (read/write) |
| 41H | Counter 1 Register (read/write) |
| 42H | Counter 2 Register (read/write) |
| 43H | Control Word Register I (Counter 0, 1 & 2) (write-only) |
| 44H | Counter 3 Register (read/write) |
| 45H | Reserved |
| 46H | Reserved |
| 47H | Control Word Register II (Counter 3) (write-only) |

5.4.1 COUNTER 0, 1, 2, 3 REGISTERS

These four 8-bit registers are functionally identical. They are used to write the initial count value into the respective timer. Also, they can be used to read the latched count value of a timer. Since they are 8-bit registers, reading and writing of the 16-bit initial count must follow the count format specified in the Control Word Registers; i.e. least significant byte only, most significant byte only, or least significant byte then most significant byte (see Programming).

5.4.2 CONTROL WORD REGISTER I & II

There are two Control Word Registers associated with the Timer section. One of the two registers (Control Word Register I) is used to control the operations of Counters 0, 1 and 2 and the other (Control Word Register II) is for Counter 3. The major functions of both Control Word Registers are listed below:

- Select the timer to be programmed.
- Define which mode the selected timer is to operate in.
- Define the count sequence; i.e. if the selected timer is to count as a Binary Counter or a Binary Coded Decimal (BCD) Counter.
- Select the byte access sequence during timer read/write operations; i.e. least significant byte only, most significant only, or least significant byte first, then most significant byte.

Also, the Control Word Registers can be programmed to perform a Counter Latch Command or a Read Back Command which will be described later.

5.5 Programming

5.5.1 INITIALIZATION

Upon power-up or reset, the state of all timers is undefined. The mode, count value, and output of all timers are random. From this point on, how each timer operates is determined solely by how it is programmed. Each timer must be programmed before it can be used. Since the outputs of some timers can generate interrupt signals to the 82370, all timers should be initialized to a known state.

Counters are programmed by writing a Control Word into their respective Control Word Registers. Then, an Initial Count can be written into the corresponding Count Register. In general, the programming procedure is very flexible. Only two conventions need to be remembered:

1. For each timer, the Control Word must be written before the initial count is written.
2. The 16-bit initial count must follow the count format specified in the Control Word (least significant byte only, most significant byte only, or least significant byte first, followed by most significant byte).

Since the two Control Word Registers and the four Counter Registers have separate addresses, and each timer can be individually selected by the appropriate Control Word Register, no special instruction sequence is required. Any programming sequence that follows the conventions above is acceptable.

A new initial count may be written to a timer at any time without affecting the timer's programmed mode in any way. Count sequence will be affected as described in the Modes of Operation section. Note that the new count must follow the programmed count format.

If a timer is previously programmed to read/write two-byte counts, the following precaution applies. A program must not transfer control between writing the first and second byte to another routine which also writes into the same timer. Otherwise, the read/write will result in incorrect count.

Whenever a Control Word is written to a timer, all control logic for that timer(s) is immediately reset (i.e. no CLK pulse is required). Also, the corresponding output in, TOUT#, goes to a known initial state.

5.5.2 READ OPERATION

Three methods are available to read the current count as well as the status of each timer. They are: Read Counter Registers, Counter Latch Command and Read Back Command. Below is a description of these methods.

READ COUNTER REGISTERS

The current count of a timer can be read by performing a read operation on the corresponding Counter Register. The only restriction of this read operation is that the CLKIN of the timers must be inhibited by using external logic. Otherwise, the count may be in the process of changing when it is read, giving an undefined result. Note that since all four timers are sharing the same CLKIN signal, inhibiting CLKIN to read a timer will unavoidably disable the other timers also. This may prove to be impractical. Therefore, it is suggested that either the Counter Latch Command or the Read Back Command can be used to read the current count of a timer.

Another alternative is to temporarily disable a timer before reading its Counter Register by using the GATE input. Depending on the mode of operation, GATE=LOW will disable the counting operation. However, this option is available on Timer 2 and 3 only, since the GATE signals of the other two timers are internally enabled all the time.

COUNTER LATCH COMMAND

A Counter Latch Command will be executed whenever a special Control Word is written into a Control Word Register. Two bits written into the Control Word Register distinguish this command from a 'regular' Control Word (see Register Bit Definition). Also, two other bits in the Control Word will select which counter is to be latched.

Upon execution of this command, the selected counter's Output Latch (OL) latches the count at the time the Counter Latch Command is received. This

count is held in the latch until it is read by the 80376, or until the timer is reprogrammed. The count is then unlatched automatically and the OL returns to "following" the Counting Element (CE). This allows reading the contents of the counters "on the fly" without affecting counting in progress. Multiple Counter Latch Commands may be used to latch more than one counter. Each latched count is held until it is read. Counter Latch Commands do not affect the programmed mode of the timer in any way.

If a counter is latched, and at some time later, it is latched again before the prior latched count is read, the second Counter Latch Command is ignored. The count read will then be the count at the time the first command was issued.

In any event, the latched count must be read according to the programmed format. Specifically, if the timer is programmed for two-byte counts, two bytes must be read. However, the two bytes do not have to be read right after the other. Read/write or programming operations of other timers may be performed between them.

Another feature of this Counter Latch Command is that read and write operations of the same timer may be interleaved. For example, if the timer is programmed for two-byte counts, the following sequence is valid.

1. Read least significant byte.
2. Write new least significant byte.
3. Read most significant byte.
4. Write new most significant byte.

If a timer is programmed to read/write two-byte counts, the following precaution applies. A program must not transfer control between reading the first and second byte to another routine which also reads from that same timer. Otherwise, an incorrect count will be read.

READ BACK COMMAND

The Read Back Command is another special Command Word operation which allows the user to read the current count value and/or the status of the selected timer(s). Like the Counter Latch Command, two bits in the Command Word identify this as a Read Back Command (see Register Bit Definition).

The Read Back Command may be used to latch multiple counter Output Latches (OL's) by selecting more than one timer within a Command Word. This single command is functionally equivalent to several Counter Latch Commands, one for each counter to

be latched. Each counter's latched count will be held until it is read by the 80376 or until the timer is reprogrammed. The counter is automatically unlatched when read, but other counters remain latched until they are read. If multiple Read Back commands are issued to the same timer without reading the count, all but the first are ignored; i.e. the count read will correspond to the very first Read Back Command issued.

As mentioned previously, the Read Back Command may also be used to latch status information of the selected timer(s). When this function is enabled, the status of a timer can be read from the Counter Register after the Read Back Command is issued. The status information of a timer includes the following:

1. Mode of timer:

This allows the user to check the mode of operation of the timer last programmed.

2. State of TOUT pin of the timer:

This allows the user to monitor the counter's output pin via software, possibly eliminating some hardware from a system.

3. Null Count/Count available:

The Null Count Bit in the status byte indicates if the last count written to the Count Register (CR) has been loaded into the Counting Element (CE). The exact time this happens depends on the mode of the timer and is described in the Programming section. Until the count is loaded into the Counting Element (CE), it cannot be read from the timer. If the count is latched or read before this occurs, the count value will not reflect the new count just written.

If multiple status latch operations of the timer(s) are performed without reading the status, all but the first command are ignored; i.e. the status read in will correspond to the first Read Back Command issued.

Both the current count and status of the selected timer(s) may be latched simultaneously by enabling both functions in a single Read Back Command. This is functionally the same as issuing two separate Read Back Commands at once. Once again, if multiple read commands are issued to latch both the count and status of a timer, all but the first command will be ignored.

If both count and status of a timer are latched, the first read operation of that timer will return the latched status, regardless of which was latched first. The next one or two (if two count bytes are to be read) read operations return the latched count. Note that subsequent read operations on the Counter Register will return the unlatched count (like the first read method discussed).

5.6 Register Bit Definitions

COUNTER 0, 1, 2, 3 REGISTER (READ/WRITE)

| Port Address | Description |
|--------------|---------------------------------|
| 40H | Counter 0 Register (read/write) |
| 41H | Counter 1 Register (read/write) |
| 42H | Counter 2 Register (read/write) |
| 44H | Counter 3 Register (read/write) |
| 45H | Reserved |
| 46H | Reserved |

Note that these 8-bit registers are for writing and reading of one byte of the 16-bit count value, either the most significant or the least significant byte.

CONTROL WORD REGISTER I & II (WRITE-ONLY)

| Port Address | Description |
|--------------|--|
| 43H | Control Word Register I (Counter 0, 1, 2 (write-only)) |
| 47H | Control Word Register II (Counter 3) (write-only) |

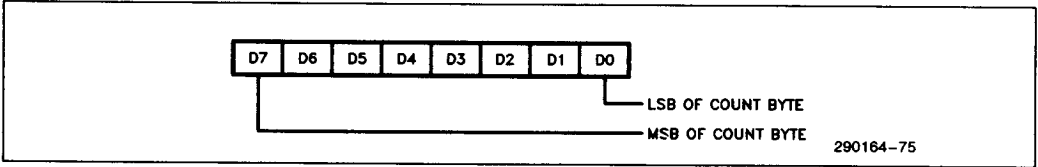

Control Word Register I

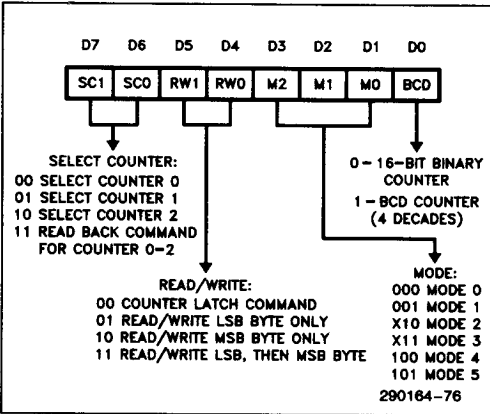

Control Word Register II

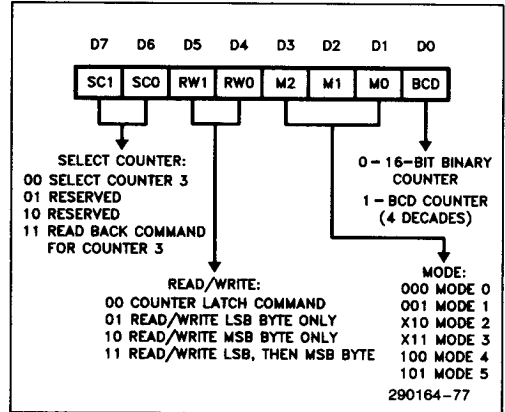

1

COUNTER LATCH COMMAND FORMAT

(Write to Control Word Register)

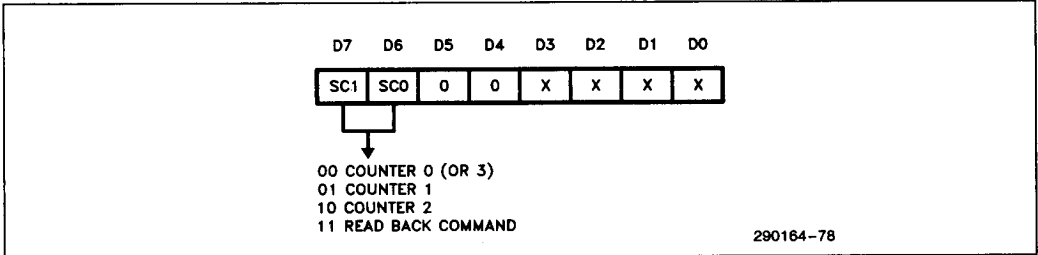

READ BACK COMMAND FORMAT

(Write to Control Word Register)

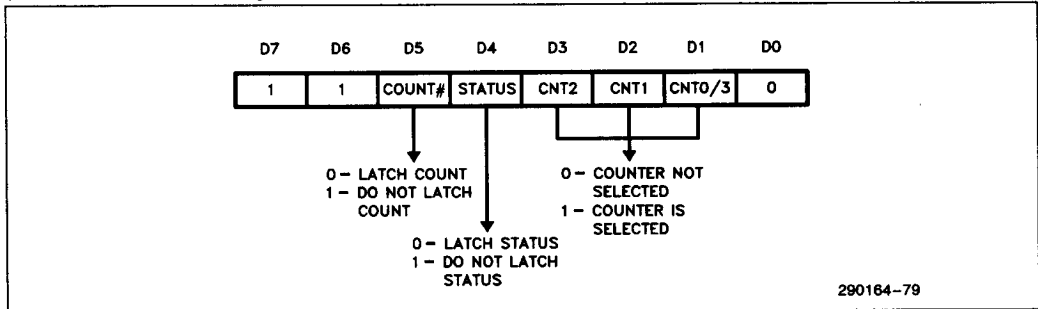

STATUS FORMAT

(Returned from Read Back Command)

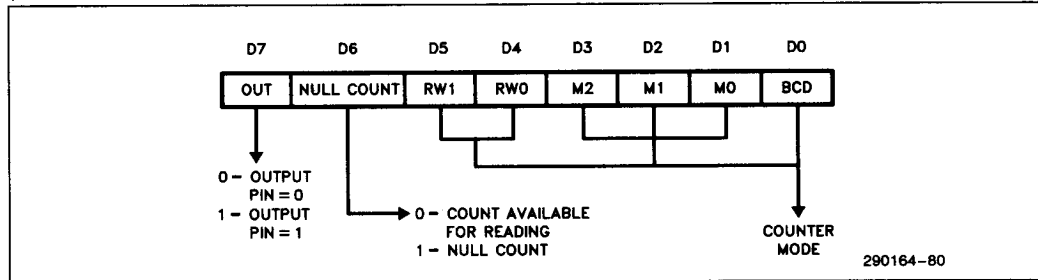

6.0 WAIT STATE GENERATOR

6.1 Functional Description

The 82370 contains a programmable Wait State Generator which can generate a pre-programmed number of wait states during both CPU and DMA initiated bus cycles. This Wait State Generator is capable of generating 1 to 16 wait states in non-pipelined mode, and 0 to 15 wait states in pipelined mode. Depending on the bus cycle type and the two Wait State Control inputs (WSC 0-1), a pre-programmed number of wait states in the selected Wait State Register will be generated.

The Wait State Generator can also be disabled to allow the use of devices capable of generating their own READY# signals. Figure 6-1 is a block diagram of the Wait State Generator.

6.2 Interface Signals

The following describes the interface signals which affect the operation of the Wait State Generator. The READY#, WSC0 and WSC1 signals are inputs. READY# is the ready output signal to the host processor.

6.2.1 READY#

READY# is an active LOW input signal which indicates to the 82370 the completion of a bus cycle. In the Master mode (e.g. 82370 initiated DMA transfer), this signal is monitored to determine whether a peripheral or memory needs wait states inserted in the current bus cycle. In the Slave mode, it is used (together with the ADS# signal) to trace CPU bus cycles to determine if the current cycle is pipelined.

6.2.2 READY#

READY# (Ready Out#) is an active LOW output signal and is the output of the Wait State Generator. The number of wait states generated depends on the WSC(0-1) inputs. Note that special cases are handled for access to the 82370 internal registers and for the Refresh cycles. For 82370 internal register access, READY# will be delayed to take into the command recovery time of the register. One or more wait states will be generated in a pipelined cycle. During refresh, the number of wait states will be determined by the preprogrammed value in the Refresh Wait State Register.

In the simplest configuration, READY# can be connected to the READY# input of the 82370 and the 80376 CPU. This is, however, not always the case. If external circuitry is to control the READY# inputs as well, additional logic will be required (see Application Issues).

6.2.3 WSC(0-1)

These two Wait State Control inputs, together with the M/IO# input, select one of the three pre-programmed 8-bit Wait State Registers which determines the number of wait states to be generated. The most significant half of the three Wait State Registers corresponds to memory accesses, the least significant half to I/O accesses. The combination WSC(0-1) = 11 disables the Wait State Generator.

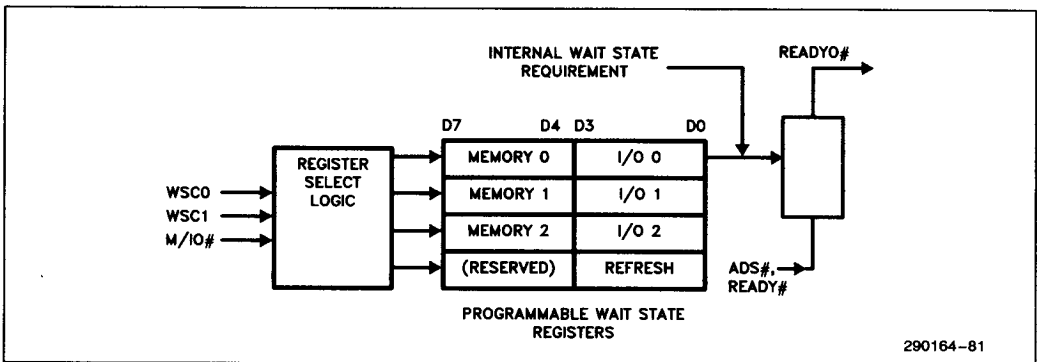

Figure 6-1. Wait State Generator Block Diagram

1

6.3 Bus Function

6.3.1 WAIT STATES IN NON-PIPELINED CYCLE

The timing diagram of two typical non-pipelined cycles with 82370 generated wait states is shown in Figure 6-2. In this diagram, it is assumed that the internal registers of the 82370 are not addressed. During the first T2 state of each bus cycle, the Wait State Control and the M/IO# inputs are sampled to determine which Wait State Register (if any) is selected. If the WCS inputs are active (i.e. not both are driven HIGH), the pre-programmed number of wait states corresponding to the selected Wait State Register will be requested. This is done by driving the READY# output HIGH during the end of each T2 state.

The WCS (0-1) inputs need only be valid during the very first T2 state of each non-pipelined cycle. As a general rule, the WCS inputs are sampled on the rising edge of the next clock (82384 CLK) after the last state when ADS# (Address Status) is asserted.

The number of wait states generated depends on the type of bus cycle, and the number of wait states requested. The various combinations are discussed below.

1. Access the 82370 internal registers: 2 to 5 wait states, depending upon the specific register addressed. Some back-to-back sequences to the Interrupt Controller will require 7 wait states.

2. Interrupt Acknowledge to the 82370: 5 wait states.

3. Refresh: As programmed in the Refresh Wait State Register (see Register Set Overview). Note that if WCS (0-1) = 11, READY# will stay inactive.

4. Other bus cycles: Depending on WCS (0-1) and M/IO# inputs, these inputs select a Wait State Register in which the number of wait states will be equal to the pre-programmed wait state count in the register plus 1. The Wait State Register selection is defined as follows (Table 6-1).

Table 6-1. Wait State Register Selection

| M/IO# | WCS(0-1) | Register Selected |
|-------|----------|--------------------------|
| 0 | 00 | WAIT REG 0 (I/O half) |
| 0 | 01 | WAIT REG 1 (I/O half) |
| 0 | 10 | WAIT REG 2 (I/O half) |
| 1 | 00 | WAIT REG 0 (MEM half) |
| 1 | 01 | WAIT REG 1 (MEM half) |
| 1 | 10 | WAIT REG 2 (MEM half) |
| X | 11 | Wait State Gen. Disabled |

The Wait State Control signals, WCS (0-1), can be generated with the address decode and the Read/Write control signals as shown in Figure 6-3.

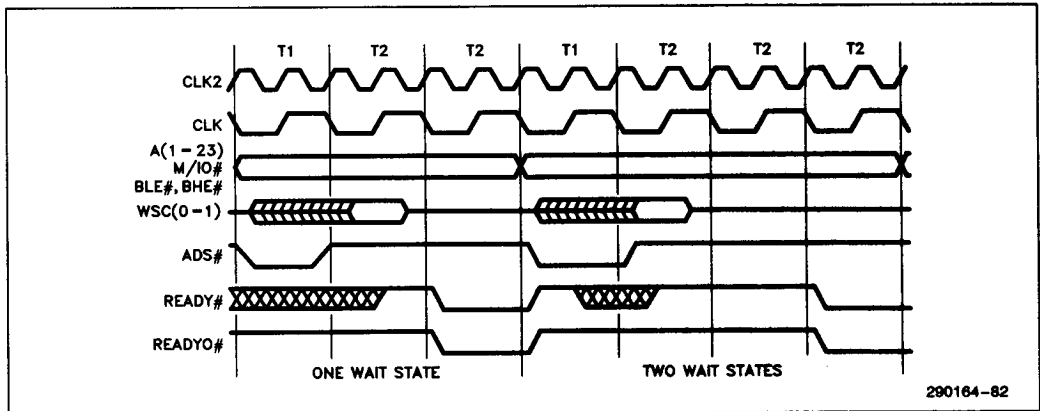

Figure 6-2. Wait States in Non-Pipelined Cycles

290164-82

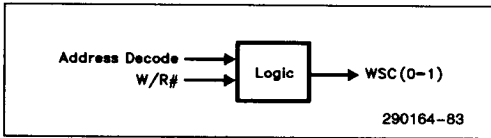

Figure 6-3. WSC (0-1) Generation

Note that during HALT and SHUTDOWN, the number of wait states will depend on the WSC (0-1) inputs, which will select the memory half of one of the Wait State Registers (see CPU Reset and Shutdown Detect).

6.3.2 WAIT STATES IN PIPELINED CYCLES

The timing diagram of two typical pipelined cycles with 82370 generated wait states is shown in Figure 6-4. Again, in this diagram, it is assumed that the 82370 internal registers are not addressed. As defined in the timing of the 80376 processor, the Address (A1-23), Byte Enable (BHE#, BLE#), and other control signals (M/IO#, ADS#) are asserted one T-state earlier than in a non-pipelined cycle; i.e. they are asserted at T2P. Similar to the non-pipelined case, the Wait State Control (WSC) inputs are sampled in the middle of the state after the last state the ADS# signal is asserted. Therefore, the WSC inputs should be asserted during the T1P state of each pipelined cycle (which is one T-state earlier than in the non-pipelined cycle).

The number of wait states generated in a pipelined cycle is selected in a similar manner as in the non-pipelined case discussed in the previous section. The only difference here is that the actual number of wait states generated will be one less than that of the non-pipelined cycle. This is done automatically by the Wait State Generator.

6.3.3 EXTENDING AND EARLY TERMINATING BUS CYCLE

The 82370 allows external logic to either add wait states or cause early termination of a bus cycle by controlling the READY# input to the 82370 and the host processor. A possible configuration is shown in Figure 6-5.

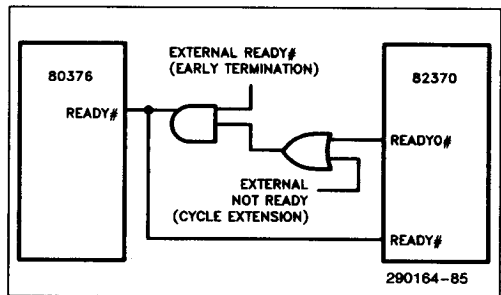

Figure 6-5. External 'READY' Control Logic

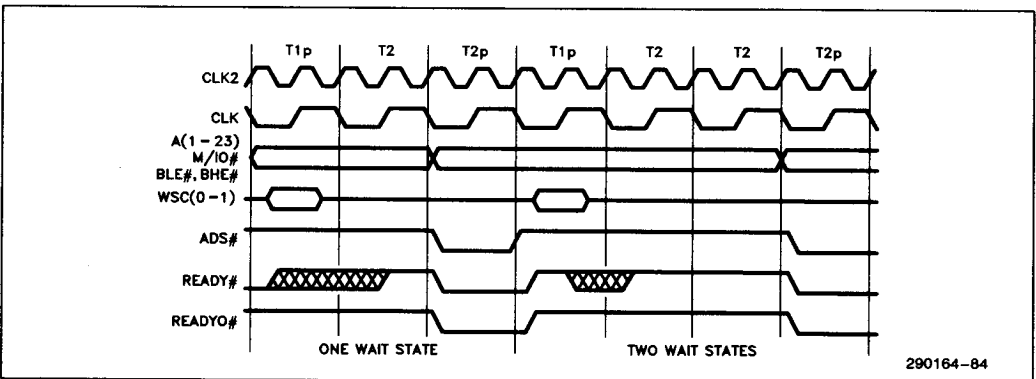

Figure 6-4. Wait States in Pipelined Cycles

The EXT. RDY# (External Ready) signal of Figure 6-5 allows external devices to cause early termination of a bus cycle. When this signal is asserted LOW, the output of the circuit will also go LOW (even though the READY# of the 82370 may still be HIGH). This output is fed to the READY# input of the 80376 and the 82370 to indicate the completion of the current bus cycle.

Similarly, the EXT. NOT READY (External Not Ready) signal is used to delay the READY# input of the processor and the 82370. As long as this signal is driven HIGH, the output of the circuit will drive the READY# input HIGH. This will effectively extend the duration of a bus cycle. However, it is important to

note that if the two-level logic is not fast enough to satisfy the READY# setup time, the OR gate should be eliminated. Instead, the 82370 Wait State Generator can be disabled by driving both WSC (0-1) HIGH. In this case, the addressed memory or I/O device should activate the external READY# input whenever it is ready to terminate the current bus cycle.

Figures 6-6 and 6-7 show the timing relationships of the ready signals for the early termination and extension of the bus cycles. Section 6-7, Application Issues, contains a detailed timing analysis of the external circuit.

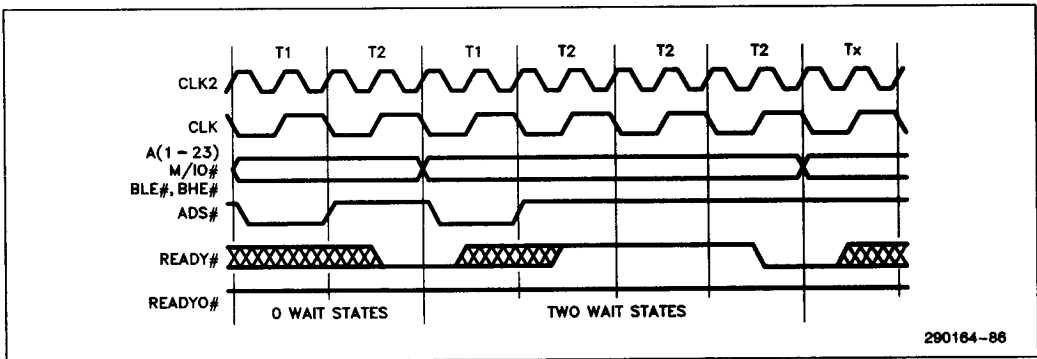

Figure 6-6. Early Termination of Bus Cycle By 'READY#'

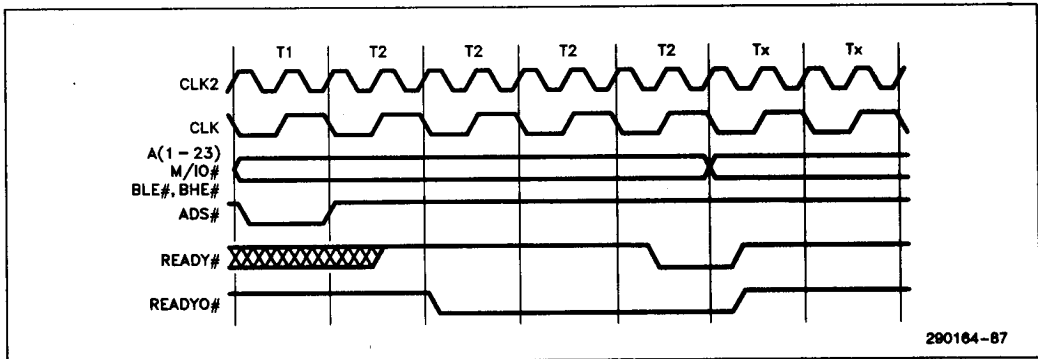

Figure 6-7. Extending Bus Cycle by 'READY#'

Due to the following implications, it should be noted that early termination of bus cycles in which 82370 internal registers are accessed is not recommended.

1. Erroneous data may be read from or written into the addressed register.
2. The 82370 must be allowed to recover either before HLDA (Hold Acknowledge) is asserted or before another bus cycle into an 82370 internal register is initiated.

The recovery time, in clock periods, equals the remaining wait states that were avoided plus 4.

6.4 Register Set Overview

Altogether, there are four 8-bit internal registers associated with the Wait State Generator. The port address map of these registers is shown below in Table 6-2. A detailed description of each follows.

Table 6-2. Register Address Map

| Port Address | Description |
|--------------|----------------------------------|
| 72H | Wait State Reg 0 (read/write) |
| 73H | Wait State Reg 1 (read/write) |
| 74H | Wait State Reg 2 (read/write) |
| 75H | Ref. Wait State Reg (read/write) |

WAIT STATE REGISTER 0, 1, 2

These three 8-bit read/write registers are functionally identical. They are used to store the pre-programmed wait state count. One half of each register contains the wait state count for I/O accesses while the other half contains the count for memory accesses. The total number of wait states generated will depend on the type of bus cycle. For a non-pipelined cycle, the actual number of wait states requested is equal to the wait state count plus 1. For a pipelined cycle, the number of wait states will be equal to the wait state count in the selected register. Therefore, the Wait State Generator is capable of generating 1 to 16 wait states in non-pipelined mode, and 0 to 15 wait states in pipelined mode.

Note that the minimum wait state count in each register is 0. This is equivalent to 0 wait states for a pipelined cycle and 1 wait state for a non-pipelined cycle.

REFRESH WAIT STATE REGISTER

Similar to the Wait State Registers discussed above, this 4-bit register is used to store the number of wait states to be generated during a DRAM refresh cycle.

Note that the Refresh Wait State Register is not selected by the WSC inputs. It will automatically be chosen whenever a DRAM refresh cycle occurs. If the Wait State Generator is disabled during the refresh cycle (WSC (0-1) = 11), READY# will stay inactive and the Refresh Wait State Register is ignored.

6.5 Programming

Using the Wait State Generator is relatively straightforward. No special programming sequence is required. In order to ensure the expected number of wait states will be generated when a register is selected, the registers to be used must be programmed after power-up by writing the appropriate wait state count into each register. Note that upon hardware reset, all Wait State Registers are initialized with the value FFH, giving the maximum number of wait states possible. Also, each register can be read to check the wait state count previously stored in the register.

6.6 Register Bit Definition

WAIT STATE REGISTER 0, 1, 2

| Port Address | Description |
|--------------|------------------------------------|
| 72H | Wait State Register 0 (read/write) |
| 73H | Wait State Register 1 (read/write) |
| 74H | Wait State Register 2 (read/write) |

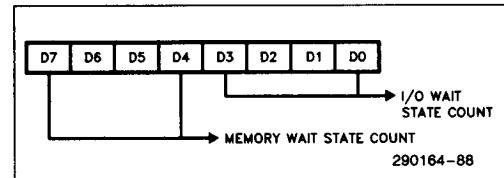

REFRESH WAIT STATE REGISTER

Port Address: 75H (Read/Write)

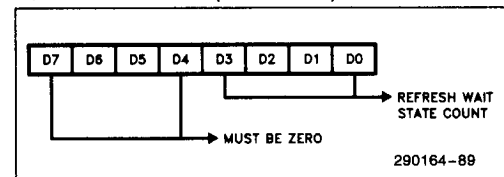

6.7 Application Issues

6.7.1 EXTERNAL 'READY' CONTROL LOGIC

As mentioned in section 6.3.3, wait state cycles generated by the 82370 can be terminated early or extended longer by means of additional external logic (see Figure 6-5). In order to ensure that the $READY\#$ input timing requirement of the 80376 and the 82370 is satisfied, special care must be taken when designing this external control logic. This section addresses the design requirements.

A simplified block diagram of the external logic along with the $READY\#$ timing diagram is shown in Figure 6-8. The purpose is to determine the maximum delay

time allowed in the external control logic in order to satisfy the $READY\#$ setup time.

First, it will be assumed that the 80376 is running at 16 MHz (i.e. CLK2 is 32 MHz). Therefore, one bus state (two CLK2 periods) will be equivalent to 62.5 ns. According to the AC specifications of the 82370, the maximum delay time for valid $READYO\#$ signal is 31 ns after the rising edge of CLK2 in the beginning of T2 (for non-pipelined cycle) or T2P (for pipelined cycle). Also, the minimum $READY\#$ setup time of the 80376 and the 82370 should be 19 ns before the rising edge of CLK2 at the beginning of the next bus state. This limits the total delay time for the external $READY\#$ control logic to be 12.5 ns (62.5–31–19) in order to meet the $READY\#$ setup timing requirement.

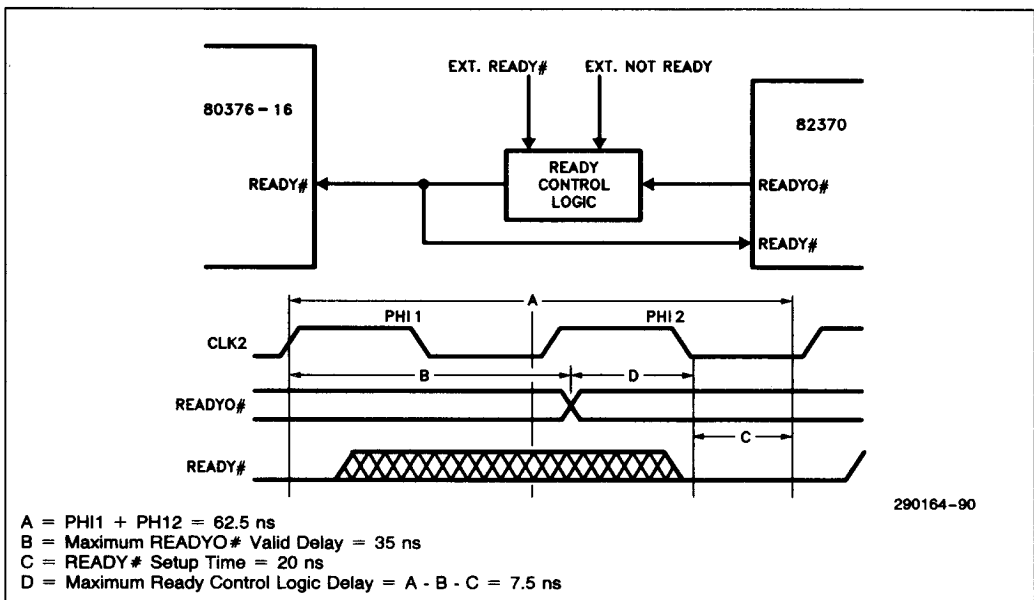

Figure 6-8. 'READY' Timing Consideration

7.0 DRAM REFRESH CONTROLLER

7.1 Functional Description

The 82370 DRAM Refresh Controller consists of a 24-bit Refresh Address Counter and Refresh Request logic for DRAM refresh operations (see Figure 7-1). TIMER 1 can be used as a trigger signal to the DRAM Refresh Request logic. The Refresh Bus Size can be programmed to be 8- or 16-bit wide. Depending on the Refresh Bus Size, the Refresh Address Counter will be incremented with the appropriate value after every refresh cycle. The internal logic of the 82370 will give the Refresh operation the highest priority in the bus control arbitration process. Bus control is not released and re-requested if the 82370 is already a bus master.

7.2 Interface Signals

7.2.1 TOUT1/REF#

The dual function output pin of TIMER 1 (TOUT1/REF#) can be programmed to generate DRAM Refresh signal. If this feature is enabled, the rising edge of TIMER 1 output (TOUT1#) will trigger the DRAM Refresh Request logic. After some delay for gaining access of the bus, the 82370 DRAM Controller will generate a DRAM Refresh signal by driving REF# output LOW. This signal is cleared after the refresh cycle has taken place, or by a hardware reset.

If the DRAM Refresh feature is disabled, the TOUT1/REF# output pin is simply the TIMER 1 output. Detailed information of how TIMER 1 operates is discussed in section 6—Programmable Interval Timer, and will not be repeated here.

7.3 Bus Function

7.3.1 ARBITRATION

In order to ensure data integrity of the DRAMs, the 82370 gives the DRAM Refresh signal the highest priority in the arbitration logic. It allows DRAM Refresh to interrupt DMA in progress in order to perform the DRAM Refresh cycle. The DMA service will be resumed after the refresh is done.

In case of a DRAM Refresh during a DMA process, the cascaded device will be requested to get off the bus. This is done by de-asserting the EDACK signal. Once DREQn goes inactive, the 82370 will perform the refresh operation. Note that the DMA controller does not completely relinquish the system bus during refresh. The Refresh Generator simply "steals" a bus cycle between DMA accesses.

Figure 7-2 shows the timing diagram of a Refresh Cycle. Upon expiration of TIMER 1, the 82370 will try to take control of the system bus by asserting HOLD. As soon as the 82370 see HLDA go active, the DRAM Refresh Cycle will be carried out by activating the REF# signal as well as the address and control signals on the system bus (Note that REF# will not be active until two CLK periods HLDA is asserted). The address bus will contain the 24-bit ad-

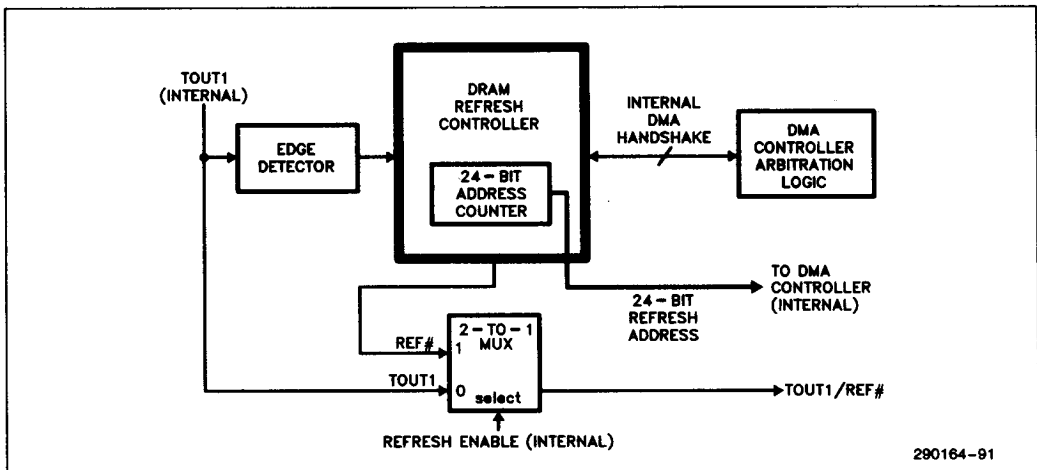

Figure 7-1. DRAM Refresh Controller

290164-91

dress currently in the Refresh Address Counter. The control signals are driven the same way as in a Memory Read cycle. This "read" operation is complete when the READY# signal is driven LOW. Then, the 82370 will relinquish the bus by de-asserting HOLD. Typically, a Refresh Cycle without wait states will take five bus states to execute. If "n" wait states are added, the Refresh Cycle will last for five plus "n" bus states.

How often the Refresh Generator will initiate a refresh cycle depends on the frequency of CLKIN as well as TIMER 1's programmed mode of operation. For this specific application, TIMER 1 should be programmed to operate in Mode 2 to generate a constant clock rate. See section 6—Programmable Interval Timer for more information on programming the timer. One DRAM Refresh Cycle will be generated each time TIMER 1 expires (when TOUT1 changes from LOW to HIGH).

The Wait State Generator can be used to insert wait states during a refresh cycle. The 82370 will automatically insert the desired number of wait states as programmed in the Refresh Wait State Register (see Wait State Generator).

7.4 Modes of Operation

7.4.1 WORD SIZE AND REFRESH ADDRESS COUNTER

The 82370 supports 8- and 16-bit refresh cycle. The bus width during a refresh cycle is programmable (see Programming). The bus size can be programmed via the Refresh Control Register (see Register Overview). If the DRAM bus size is 8- or 16-bits, the Refresh Address Counter will be incremented by 1 or 2, respectively.

The Refresh Address Counter is cleared by a hardware reset.

7.5 Register Set Overview

The Refresh Generator has two internal registers to control its operation. They are the Refresh Control Register and the Refresh Wait State Register. Their port address map is shown in Table 7-1.

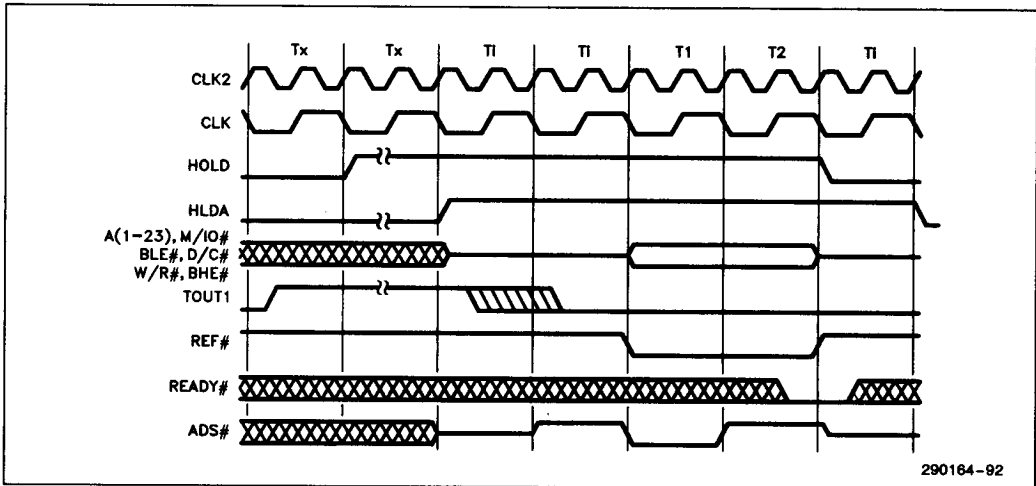

Figure 7-2. 82370 Refresh Cycle

290164-92

Table 7-1. Register Address Map

| Port Address | Description |
|--------------|-----------------------------------|
| 1CH | Refresh Control Reg. (read/write) |
| 75H | Ref. Wait State Reg. (read/write) |

The Refresh Wait State Register is not part of the Refresh Generator. It is only used to program the number of wait states to be inserted during a refresh cycle. This register is discussed in detailed in section 7 (Wait State Generator) and will not be repeated here.

REFRESH CONTROL REGISTER

This 2-bit register serves two functions. First, it is used to enable/disable the DRAM Refresh function output. If disabled, the output of TIMER 1 is simply used as a general purpose timer. The second function of this register is to program the DRAM bus size for the refresh operation. The programmed bus size also determines how the Refresh Address Counter will be incremented after each refresh operation.

7.6 Programming

Upon hardware reset, the DRAM Refresh function is disabled (the Refresh Control Register is cleared). The following programming steps are needed before the Refresh Generator can be used. Since the rate of refresh cycles depends on how TIMER 1 is programmed, this timer must be initialized with the desired mode of operation as well as the correct refresh interval (see Programming Interval Timer). Whether or not wait states are to be generated during a refresh cycle, the Refresh Wait State Register must also be programmed with the appropriate value. Then, the DRAM Refresh feature must be enabled and the DRAM bus width should be defined. These can be done in one step by writing the appropriate control word into the Refresh Control Register

(see Register Bit Definition). After these steps are done, the refresh operation will automatically be invoked by the Refresh Generator upon expiration of Timer 1.

In addition to the above programming steps, it should be noted that after reset, although the TOUT1/REF# becomes the Time 1 output, the state of this pin in undefined. This is because the Timer module has not been initialized yet. Therefore, if this output is used as a DRAM Refresh signal, this pin should be disqualified by external logic until the Refresh function is enabled. One simple solution is to logically AND this output with HLDA, since HLDA should not be active after reset.

1

7.7 Register Bit Definition

REFRESH CONTROL REGISTER

Port Address: 1CH (Read/Write)

8.0 RELOCATION REGISTER, ADDRESS DECODE, AND CHIP-SELECT (CHPSEL #)

8.1 Relocation Register

All the integrated peripheral devices in the 82370 are controlled by a set of internal registers. These registers span a total of 256 consecutive address locations (although not all the 256 locations are used). The 82370 provides a Relocation Register which allows the user to map this set of internal registers into either the memory or I/O address space. The function of the Relocation Register is to define the base address of the internal register set of the 82370 as well as if the registers are to be memory- or I/O-mapped. The format of the Relocation Register is depicted in Figure 8-1.

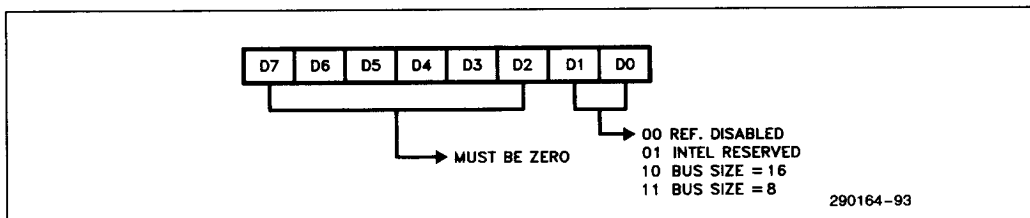

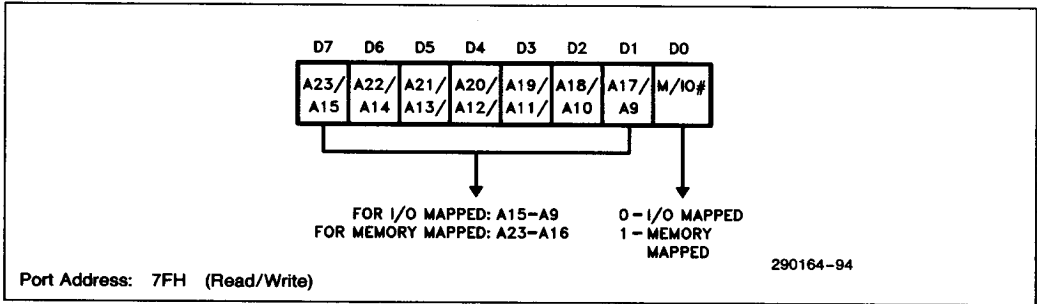

Figure 8-1. Relocation Register

Note that the Relocation Register is part of the internal register set of the 82370. It has a port address of 7FH. Therefore, any time the content of the Relocation Register is changed, the physical location of this register will also be moved. Upon reset of the 82370, the content of the Relocation Register will be cleared. This implies that the 82370 will respond to its I/O addresses in the range of 0000H to 00FFH.

8.1.1 I/O-MAPPED 82370

As shown in the figure, Bit 0 of the Relocation Register determines whether the 82370 registers are to be memory-mapped or I/O mapped. When Bit 0 is set to '0', the 82370 will respond to I/O Addresses. Address signals BHE#, BLE#, A1-A7 will be used to select one of the internal registers to be accessed. Bit 1 to Bit 7 of the Relocation Register will correspond to A9 to A15 of the Address bus, respectively. Together with A8 implied to be '0', A15 to A8 will be fully decoded by the 82370. The following shows how the 82370 is mapped into the I/O address space.

Example

Relocation Register = 11001110 (0CEH)

82370 will respond to I/O address range from 0CE00H to 0CEFFH.

Therefore, this I/O mapping mechanism allows the 82370 internal registers to be located on any even, contiguous, 256 byte boundary of the system I/O space.

8.1.2 MEMORY-MAPPED 82370

When Bit 0 of the Relocation Register is set to '1', the 82370 will respond to memory addresses. Again,

Address signals BHE#, BLE#, A1-A7 will be used to select one of the internal registers to be accessed. Bit 1 to Bit 7 of the Relocation Register will correspond to A17-A23, respectively. A16 is assumed to be '0', and A8-A15 are ignored. Consider the following example.

Example

Relocation Register = 10100111 (0A7H)

The 82370 will respond to memory addresses in the range of A6XX00H to A6XXFFH (where 'X' is don't care).

This scheme implies that the internal registers can be located in any even, contiguous, 2**16 byte page of the memory space.

8.2 Address Decoding

As mentioned previously, the 82370 internal registers do not occupy the entire contiguous 256 address locations. Some of the locations are 'unoccupied'. The 82370 always decodes the lower 8 address signals (BHE#, BLE#, A1-A7) to determine if any one of its registers is being accessed. If the address does not correspond to any of its registers, the 82370 will not respond. This allows external devices to be located within the 'holes' in the 82370 address space. Note that there are several unused addresses reserved for future Intel peripheral devices.

8.3 Chip-Select (CHPSEL #)

The Chip-Select signal (CHPSEL#) will go active when the 82370 is addressed in a Slave bus

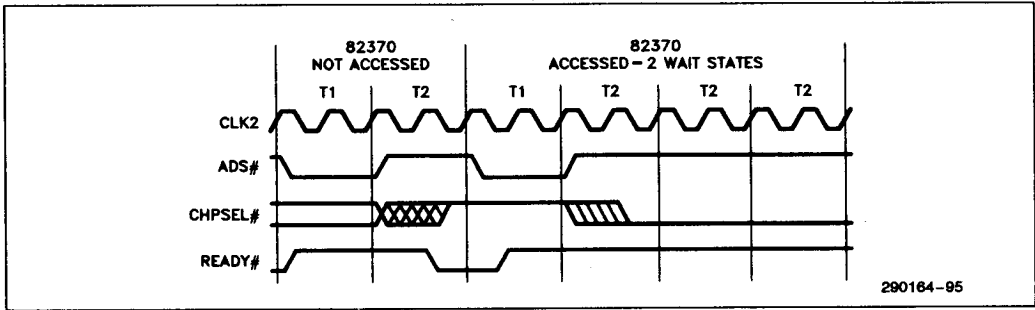

Figure 8-2. CHPSEL# Timing

cycle (either read or write), or in an interrupt acknowledge cycle in which the 82370 will drive the Data Bus. For a given bus cycle, CHPSEL# becomes active and valid in the first T2 (in a non-pipelined cycle) or in T1P (in a pipelined cycle). It will stay valid until the cycle is terminated by READY# driven active. As CHPSEL# becomes valid well before the 82370 drives the Data Bus, it can be used to control the transceivers that connect the local CPU bus to the system bus. The timing diagram of CHPSEL# is shown in Figure 8-2.

9.0 CPU RESET AND SHUTDOWN DETECT

The 82370 will activate the CPURST signal to reset the host processor when one of the following conditions occurs:

- 82370 RESET is active;
- 82370 detects a 80376 Shutdown cycle (this feature can be disabled);
- CPURST software command is issued to 80376.

Whenever the CPURST signal is activated, the 82370 will reset its own internal Slave-Bus state machine.

9.1 Hardware Reset

Following a hardware reset, the 82370 will assert its CPURST output to reset the host processor. This output will stay active for as long as the RESET input is active. During a hardware reset, the 82370 internal registers will be initialized as defined in the corresponding functional descriptions.

9.2 Software Reset

CPURST can be generated by writing the following bit pattern into 82370 register location 64H.

```
D7       . . . . D0
1 1 1 1 X X X 0
```

The Write operation into this port is considered as an 82370 access and the internal Wait State Generator will automatically determine the required number of wait states. The CPURST will be active following the completion of the Write cycle to this port. This signal will last for 80 CLK2 periods. The 82370 should not be accessed until the CPURST is deactivated.

This internal port is Write-Only and the 82370 will not respond to a Read operation to this location. Also, during a software reset command, the 82370 will reset its Slave-Bus state machine. However, its internal registers remain unchanged. This allows the operating system to distinguish a 'warm' reset by reading any 82370 internal register previously programmed for a non-default value. The Diagnostic registers can be used for this purpose (see Internal Control and Diagnostic Ports).

9.3 Shutdown Detect

The 82370 is constantly monitoring the Bus Cycle Definition signals (M/IO#, D/C#, W/R#) and is able to detect when the 80376 is in a Shutdown bus cycle. Upon detection of a processor shutdown, the 82370 will activate the CPURST output for 62 CLK2 periods to reset the host processor. This signal is generated after the Shutdown cycle is terminated by the READY# signal.

Although the 82370 Wait State Generator will not automatically respond to a Shutdown (or Halt) cycle, the Wait State Control inputs (WSC0, WSC1) can be used to determine the number of wait states in the same manner as other non-82370 bus cycles.

This Shutdown Detect feature can be enabled or disabled by writing a control bit in the Internal Control Port at address 61H (see Internal Control and Diagnostic Ports). This feature is disabled upon a hardware reset of the 82370. As in the case of Software Reset, the 82370 will reset its Slave-Bus state machine but will not change any of its internal register contents.

10.0 INTERNAL CONTROL AND DIAGNOSTIC PORTS

10.1 Internal Control Port

The format of the Internal Control Port of the 82370 is shown in Figure 10-1. This Control Port is used to enable/disable the Processor Shutdown Detect mechanism as well as controlling the Gate inputs of the Timer 2 and 3. Note that this is a Write-Only port. Therefore, the 82370 will not respond to a read operation to this port. Upon hardware reset, this port will be cleared; i.e., the Shutdown Detect feature and the Gate inputs of Timer 2 and 3 are disabled.

Port Address: 61H (Write only)

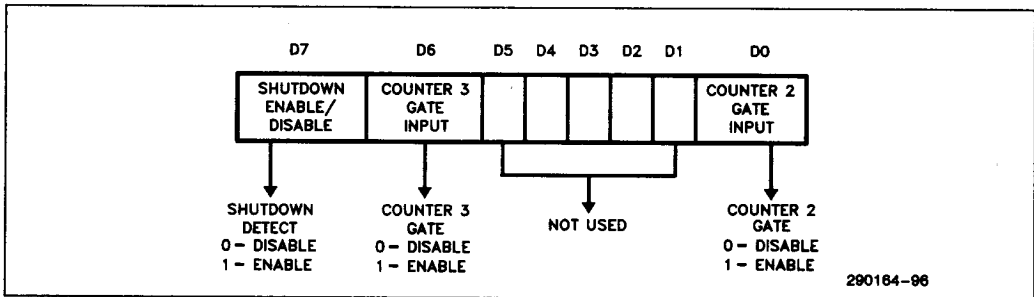

Figure 10-1. Internal Control Port

10.2 Diagnostic Ports

Two 8-bit read/write Diagnostic Ports are provided in the 82370. These are two storage registers and have no effect on the operation of the 82370. They can be used to store checkpoint data or error codes in the power-on sequence and in the diagnostic service routines. As mentioned in the CPU RESET AND SHUTDOWN DETECT section, these Diagnostic Ports can be used to distinguish between 'cold' and 'warm' reset. Upon hardware reset, both Diagnostic Ports are cleared. The address map of these Diagnostic Ports is shown in Figure 10-2.

| Port | Address |
|--------------------------------|---------|
| Diagnostic Port 1 (Read/Write) | 80H |
| Diagnostic Port 2 (Read/Write) | 88H |

Figure 10-2. Address Map of Diagnostic Ports

11.0 INTEL RESERVED I/O PORTS

There are nineteen I/O ports in the 82370 address space which are reserved for Intel future peripheral device use only. Their address locations are: 10H, 12H, 14H, 16H, 2AH, 3DH, 3EH, 45H, 46H, 76H, 77H, 7DH, 7EH, CCH, CDH, D0H, D2H, D4H, and D6H. These addresses should not be used in the system since the 82370 will respond to read/write operations to these locations and bus contention may occur if any peripheral is assigned to the same address location.

12.0 PACKAGE THERMAL SPECIFICATIONS

The intel 82370 Integrated System Peripheral is specified for operation when case temperature is within the range of 0°C to 96°C for the ceramic 132-pin PGA package, and 94°C for the 100-pin plastic package. The case temperature may be measured in any environment, to determine whether the 82370 is within specified operating range. The case temperature should be measured at the center of the top surface opposite the pins.

The ambient temperature is guaranteed as long as T_c is not violated. The ambient temperature can be

calculated from the θ_{jc} and θ_{ja} from the following equations:

$$T_j = T_c + P \cdot \theta_{jc}$$

$$T_A = T_j - P \cdot \theta_{ja}$$

$$T_c = T_a + P \cdot [\theta_{ja} - \theta_{jc}]$$

Values for θ_{ja} and θ_{jc} are given in Table 12.1 for the 100-lead fine pitch. θ_{ja} is given at various airflows. Table 12.2 shows the maximum T_a allowable (without exceeding T_c) at various airflows. Note that T_a can be improved further by attaching "fins" or a "heat sink" to the package. P is calculated using the maximum *hot* I_{cc} .



Table 12.1 82370 Package Thermal Characteristics
Thermal Resistances (°C/Watt) θ_{jc} and θ_{ja}

| Package | θ_{jc} | θ_{ja} Versus Airflow-ft ³ /min (m ³ /sec) | | | | | |
|-----------------|---------------|---|---------------|---------------|---------------|---------------|----------------|
| | | 0 (0) | 200 (1.01) | 400 (2.03) | 600 (3.04) | 800 (4.06) | 1000 (5.07) |
| 100L Fine Pitch | 7 | 33 | 27 | 24 | 21 | 18 | 17 |
| 132L PGA | 2 | 21 | 17 | 14 | 12 | 11 | 10 |

Table 12.2 82370 Maximum Allowable Ambient Temperature at Various Airflows

| Package | θ_{jc} | $T_a(c)$ Versus Airflow-ft ³ /min (m ³ /sec) | | | | | |
|-----------------|---------------|--|---------------|---------------|---------------|---------------|----------------|
| | | 0 (0) | 200 (1.01) | 400 (2.03) | 600 (3.04) | 800 (4.06) | 1000 (5.07) |
| 100L Fine Pitch | 7 | 63 | 74 | 79 | 85 | 91 | 92 |
| 132L PGA | 2 | 74 | 83 | 88 | 93 | 97 | 99 |

100L PQFP Pkg:
 $T_c = T_a + P \cdot (\theta_{ja} - \theta_{jc})$
 $T_c = 63 + 1.21(33 - 7)$
 $T_c = 63 + 1.21(26)$
 $T_c = 63 + 31.46$
 $T_c = 94^\circ\text{C}$

132L PGA Pkg:
 $T_c = T_a + P \cdot (\theta_{ja} - \theta_{jc})$
 $T_c = 74 + 1.21(21 - 2)$
 $T_c = 74 + 1.21(19)$
 $T_c = 74 + 22.99$
 $T_c = 96^\circ\text{C}$

13.0 ELECTRICAL SPECIFICATIONS

82370 D.C. Specifications Functional Operating Range:
 $V_{CC} = 5.0V \pm 10\%$; $T_{CASE} = 0^{\circ}C$ to $96^{\circ}C$ for 132-pin PGA, $0^{\circ}C$ to $94^{\circ}C$ for 100-pin plastic

| Symbol | Parameter Description | Min | Max | Units | Notes |
|---------------------|--|----------------|----------------|---------|-----------------------------------|
| V_{IL} | Input Low Voltage | -0.3 | 0.8 | V | (Note 1) |
| V_{IH} | Input High Voltage | 2.0 | $V_{CC} + 0.3$ | V | |
| V_{ILC} | CLK2 Input Low Voltage | -0.3 | 0.8 | V | (Note 1) |
| V_{IHC} | CLK2 Input High Voltage | $V_{CC} - 0.8$ | $V_{CC} + 0.3$ | V | |
| V_{OL} | Output Low Voltage $I_{OL} = 4$ mA: A ₁₋₂₃ , D ₀₋₁₅ , BHE#, BLE# $I_{OL} = 5$ mA: All Others | | 0.45 0.45 | V V | |
| V_{OH} | Output High Voltage | | | | |
| $I_{OH} = -1$ mA | A _{23-A1} , D _{15-D0} , BHE#, BLE# | 2.4 | | V | (Note 5) |
| $I_{OH} = -0.2$ mA | A _{23-A1} , D _{15-D0} , BHE#, BLE# | $V_{CC} - 0.5$ | | V | (Note 5) |
| $I_{OH} = -0.9$ mA | All Others | 2.4 | | V | (Note 5) |
| $I_{OH} = -0.18$ mA | All Others | $V_{CC} - 0.5$ | | V | (Note 5) |
| I_{LI} | Input Leakage Current All Inputs Except: IRQ1# - IRQ23# EOP#, TOUT2/IRQ3# DREQ4/IRQ9# | | ± 15 | μA | |
| I_{LI1} | Input Leakage Current Inputs: IRQ11# - IRQ23# EOP#, TOUT2/IRQ3 DREQ4/IRQ9 | 10 | -300 | μA | $0 < V_{IN} < V_{CC}$ (Note 3) |
| I_{LO} | Output Leakage Current | | ± 15 | μA | $0 < V_{IN} < V_{CC}$ |
| I_{CC} | Supply Current (CLK2 = 32 MHz) | | 220 | mA | (Note 4) |
| C_I | Input Capacitance | | 12 | pF | (Note 2) |
| C_{CLK} | CLK2 Input Capacitance | | 20 | pF | (Note 2) |

NOTES:

- Minimum value is not 100% tested.
- $f_C = 1$ MHz; sampled only.
- These pins have weak internal pullups. They should not be left floating.
- I_{CC} is specified with inputs driven to CMOS levels, and outputs driving CMOS loads. I_{CC} may be higher if inputs are driven to TTL levels, or if outputs are driving TTL loads.
- Tested at the minimum operating frequency of the part.

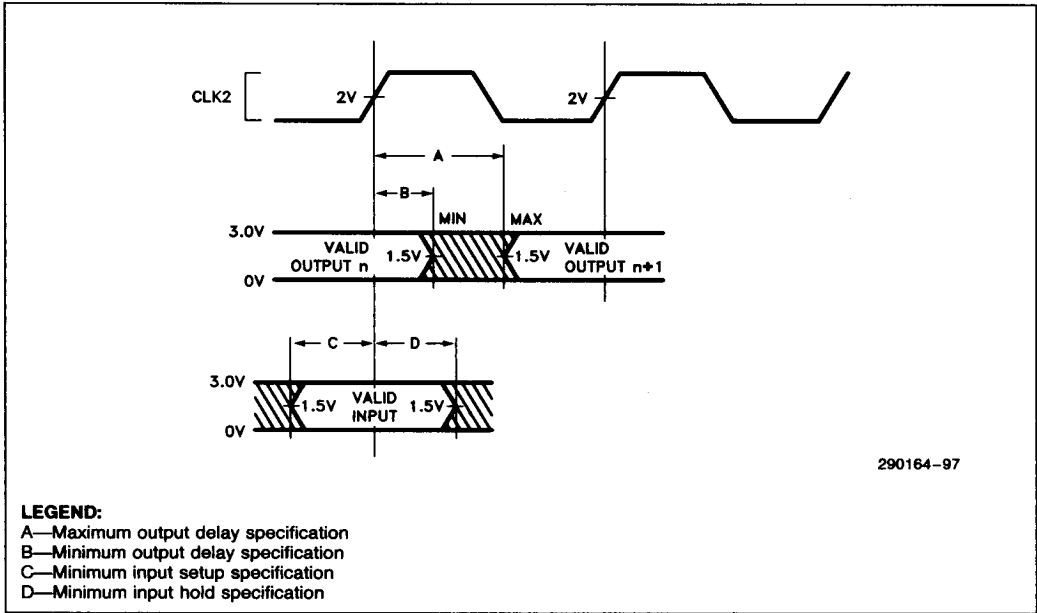

290164-97

Figure 13-1. Drive Levels and Measurement Points for A.C. Specification

82370 A.C. Specifications These A.C. timings are tested at 1.5V thresholds, except as noted.
 Functional Operating Range: $V_{CC} = 5.0V \pm 10\%$; $T_{CASE} = 0^{\circ}C$ to $96^{\circ}C$ for 132-pin PGA, $0^{\circ}C$ to $94^{\circ}C$ for 100-pin plastic

| Symbol | Parameter Description | Min | Max | Units | Notes |
|--------|---|-----|-----|-------|-------------------------|
| | Operating Frequency $1/(t_{1a} \times 2)$ | 4 | 16 | MHz | |
| t1 | CLK2 Period | 31 | 125 | ns | |
| t2a | CLK2 High Time | 9 | | ns | At 2.0V |
| t2b | CLK2 High Time | 5 | | ns | At $V_{CC} - 0.8V$ |
| t3a | CLK2 Low Time | 9 | | ns | At 2.0V |
| t3b | CLK2 Low Time | 7 | | ns | At 0.8V |
| t4 | CLK2 Fall Time | | 7 | ns | $V_{CC} - 0.8V$ to 0.8V |
| t5 | CLK2 Rise Time | | 7 | ns | 0.8V to $V_{CC} - 0.8V$ |
| t6 | A1-A23, BHE #, BLE # EDACK0-EDACK2 Valid Delay | 4 | 36 | ns | $C_L = 120$ pF |
| t7 | A1-A23, BHE #, BLE # EDACK0-EDACK3 Float Delay | 4 | 40 | ns | (Note 1) |
| t8 | A1-A23, BHE #, BLE # Setup Time | 6 | | ns | |
| t9 | A1-A23, BHE #, BLE # Hold Time | 4 | | ns | |
| t10 | W/R #, M/IO #, D/C # Valid Delay | 4 | 33 | ns | $C_L = 75$ pF |
| t11 | W/R #, M/IO #, D/C # Float Delay | 4 | 35 | ns | (Note 1) |

82370 A.C. Specifications These A.C. timings are tested at 1.5V thresholds, except as noted.
 Functional Operating Range: $V_{CC} = 5.0V \pm 10\%$; $T_{CASE} = 0^{\circ}C$ to $96^{\circ}C$ for 132-pin PGA, $0^{\circ}C$ to $94^{\circ}C$ for 100-pin plastic (Continued)

| Symbol | Parameter Description | Min | Max | Units | Notes |
|--------|--|-----|-----|-------|----------------------------|
| t12 | W/R#, M/IO#, D/C# Setup Time | 6 | | ns | |
| t13 | W/R#, M/IO#, D/C# Hold Time | 4 | | ns | |
| t14 | ADS# Valid Delay | 6 | 33 | ns | $C_L = 50$ pF (Note 1) |
| t15 | ADS# Float Delay | 4 | 35 | ns | |
| t16 | ADS# Setup Time | 21 | | ns | |
| t17 | ADS# Hold Time | 4 | | ns | |
| t18 | Slave Mode D0–D15 Read Valid | 3 | 46 | ns | $C_L = 120$ pF (Note 1) |
| t19 | Slave Mode D0–D15 Read Float | 6 | 35 | ns | |
| t20 | Slave Mode D0–D15 Write Setup | 31 | | ns | |
| t21 | Slave Mode D0–D15 Write Hold | 26 | | ns | |
| t22 | Master Mode D0–D15 Write Valid | 4 | 40 | ns | $C_L = 120$ pF (Note 1) |
| t23 | Master Mode D0–D15 Write Float | 4 | 35 | ns | |
| t24 | Master Mode D0–D15 Read Setup | 8 | | ns | |
| t25 | Master Mode D0–D15 Read Hold | 6 | | ns | |
| t26 | READY# Setup Time | 19 | | ns | |
| t27 | READY# Hold Time | 4 | | ns | |
| t28 | WSC0–WSC1 Setup Time | 6 | | ns | |
| t29 | WSC0–WSC1 Hold Time | 21 | | ns | |
| t30 | RESET Setup Time | 13 | | ns | |
| t31 | RESET Hold Time | 4 | | ns | |
| t32 | READYO# Valid Delay | 4 | 31 | ns | $C_L = 25$ pF |
| t33 | CPURST Valid Delay (Falling Edge Only) | 2 | 18 | ns | $C_L = 50$ pF |
| t34 | HOLD Valid Delay | 5 | 33 | ns | $C_L = 100$ pF |
| t35 | HLDA Setup Time | 21 | | ns | |
| t36 | HLDA Hold Time | 6 | | ns | |
| t37a | EOP# Setup (Synchronous) | 21 | | ns | |
| t38a | EOP# Hold (Synchronous) | 6 | | ns | |
| t37b | EOP# Setup (Asynchronous) | 11 | | ns | |
| t38b | EOP# Hold (Asynchronous) | 11 | | ns | |
| t39 | EOP# Valid Delay (Falling Edge Only) | 5 | 38 | ns | $C_L = 100$ pF (Note 1) |
| t40 | EOP# Float Delay | 5 | 40 | ns | |
| t41a | DREQ Setup (Synchronous) | 21 | | ns | |
| t42a | DREQ Hold (Synchronous) | 4 | | ns | |
| t41b | DREQ Setup (Asynchronous) | 11 | | ns | |
| t42b | DREQ Hold (Asynchronous) | 11 | | ns | |
| t43 | INT Valid Delay from IRQn | | 500 | ns | |
| t44 | NA# Setup Time | 5 | | ns | |
| t45 | NA# Hold Time | 15 | | ns | |

82370 A.C. Specifications These A.C. timings are tested at 1.5V thresholds, except as noted.
 Functional Operating Range: $V_{CC} = 5.0V \pm 10\%$; $T_{CASE} = 0^{\circ}C$ to $96^{\circ}C$ for 132-pin PGA, $0^{\circ}C$ to $94^{\circ}C$ for 100-pin plastic (Continued)

| Symbol | Parameter Description | Min | Max | Units | Notes |
|--------|---|-----|-----|-------|----------------|
| t46 | CLKIN Frequency | DC | 10 | MHz | |
| t47 | CLKIN High Time | 30 | | ns | 2.0V |
| t48 | CLKIN Low Time | 50 | | ns | 0.8V |
| t49 | CLKIN Rise Time | | 10 | ns | 0.8V to 3.7V |
| t50 | CLKIN Fall Time | | 10 | ns | 3.7V to 0.8V |
| t51 | TOUT1 # / REF # Valid Delay from CLK2 (Refresh) | 4 | 36 | ns | $C_L = 120$ pF |
| t52 | from CLKIN (Timer) | 3 | 93 | ns | $C_L = 120$ pF |
| t53 | TOUT2 # Valid Delay (from CLKIN, Falling Edge Only) | 3 | 93 | ns | $C_L = 120$ pF |
| t54 | TOUT2 # Float Delay | 3 | 36 | ns | (Note 1) |
| t55 | TOUT3 # Valid Delay (from CLKIN) | 3 | 93 | ns | $C_L = 120$ pF |
| t56 | CHPSEL # Valid Delay | 1 | 35 | ns | $C_L = 25$ pF |

1

NOTE:

1. Float condition occurs when the maximum output current becomes less than I_{LO} in magnitude. Float delay is not tested. For testing purposes, the float condition occurs when the dynamic output driven voltage changes with current loads.

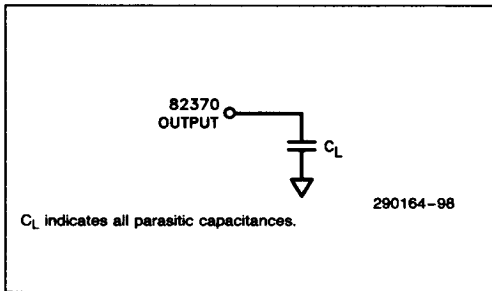

Figure 13-2. A.C. Test Load

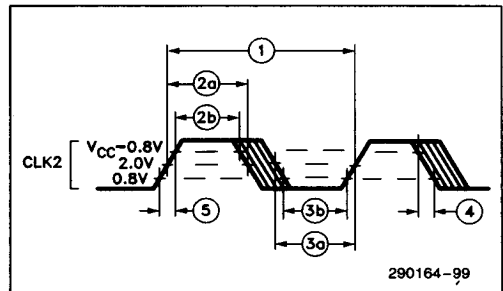

Figure 13-3

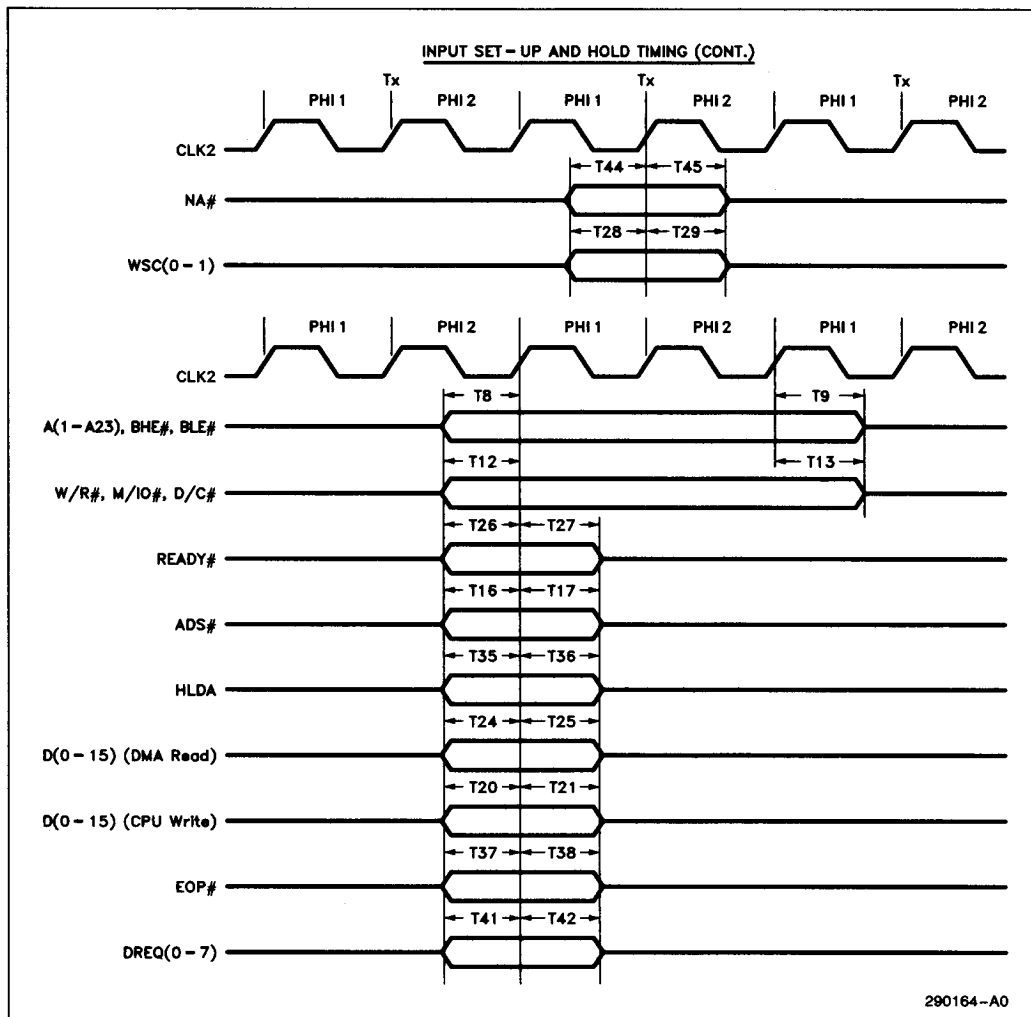

Figure 13-4. Input Setup and Hold Timing

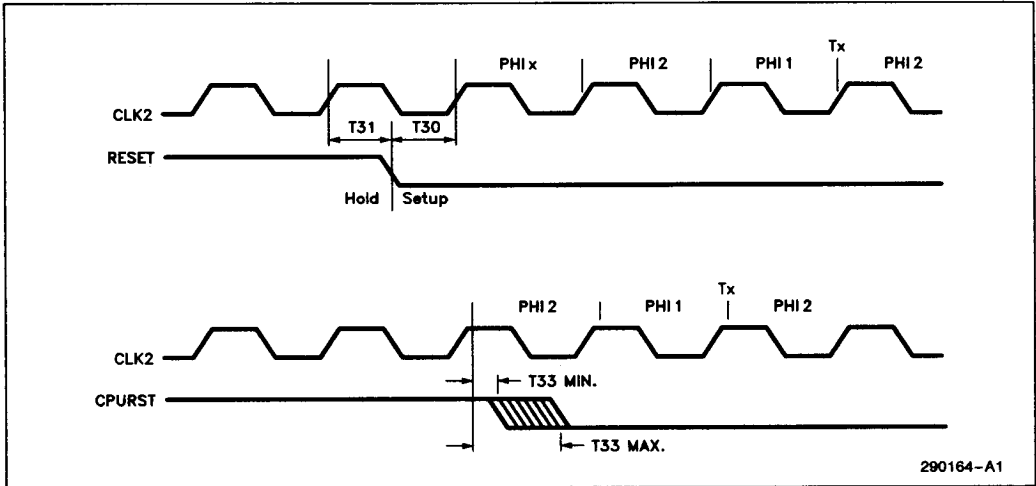

Figure 13-5. Reset Timing

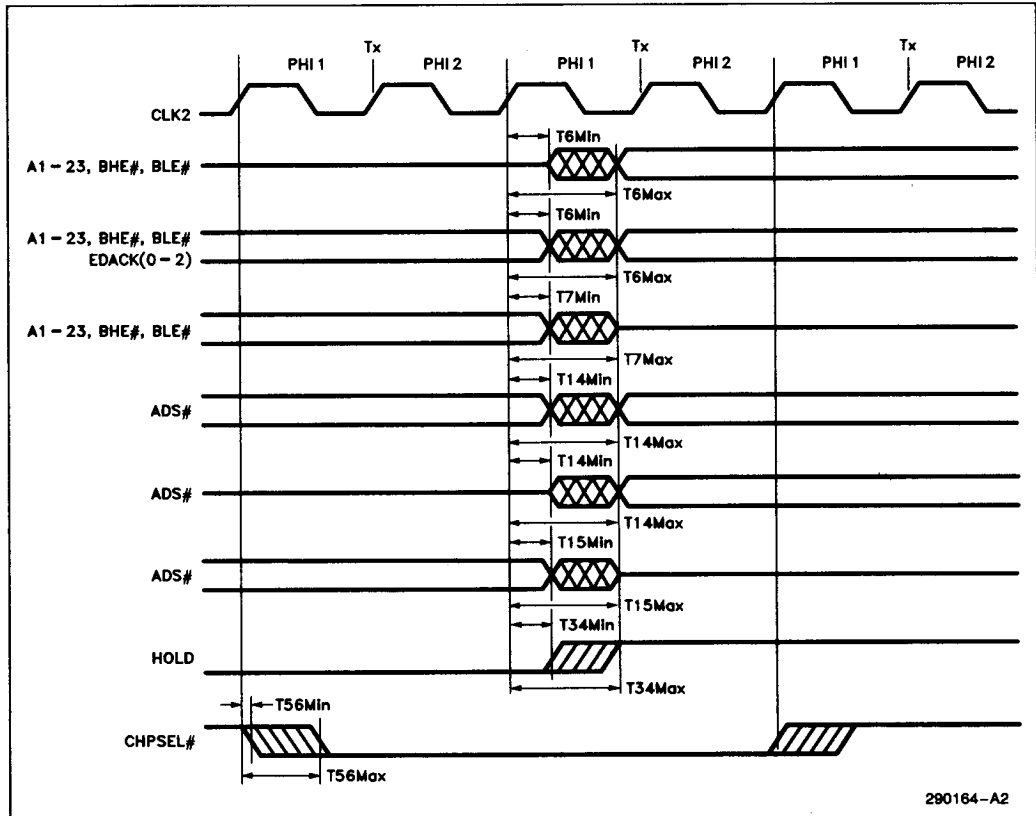
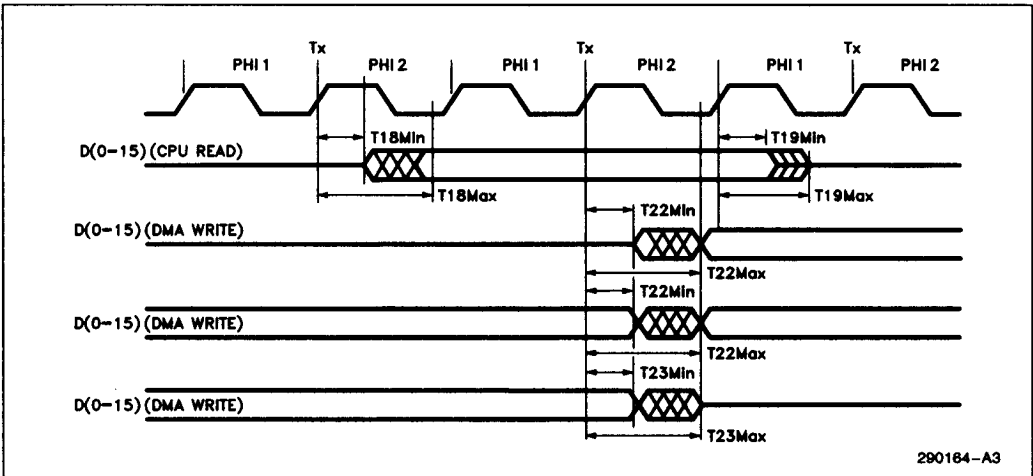

Figure 13-6. Address Output Delays

1



290164-A3

Figure 13-7. Data Bus Output Delays

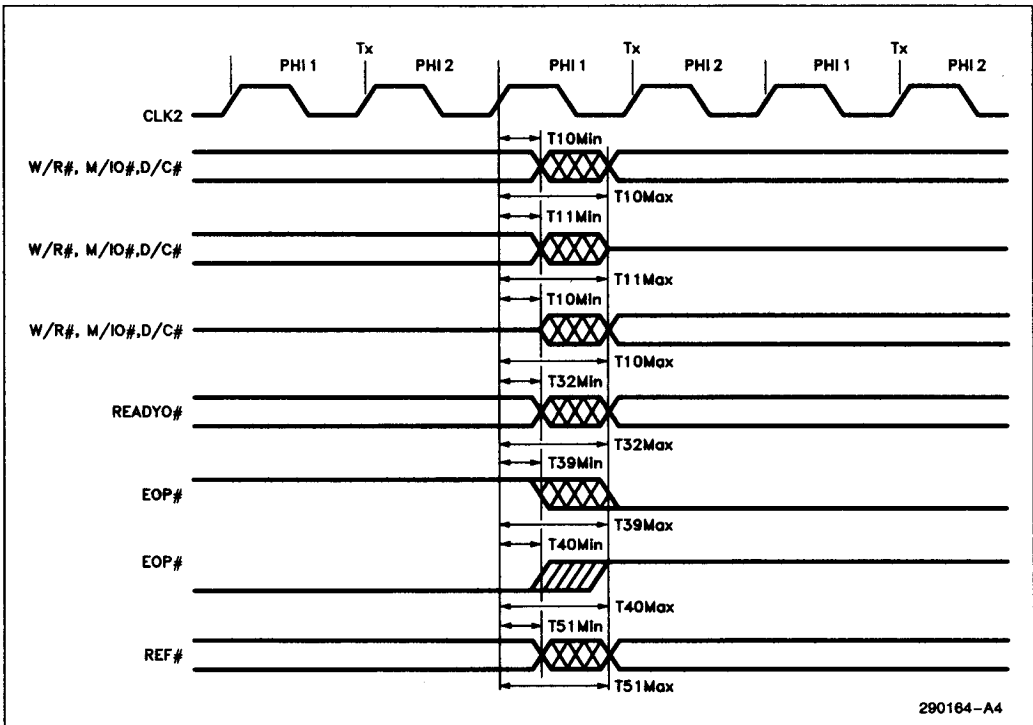

290164-A4

Figure 13-8. Control Output Delays

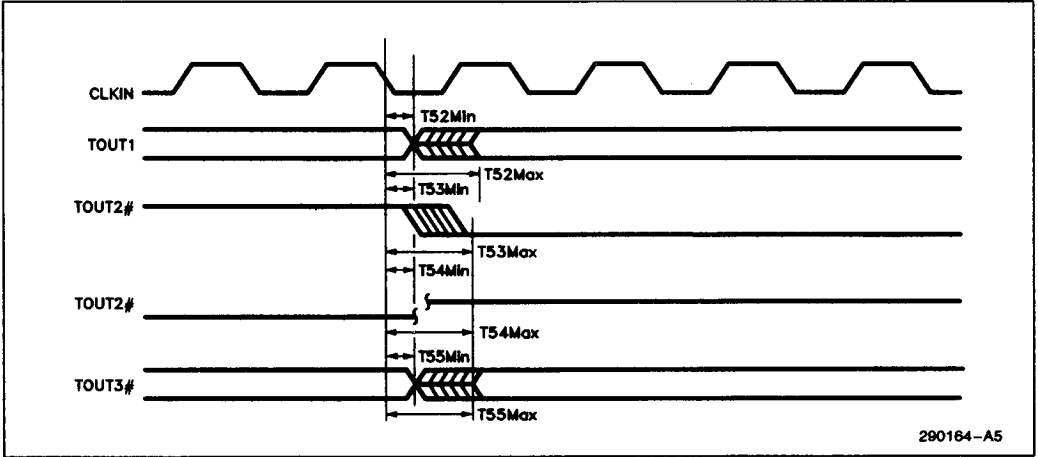

Figure 13-9. Timer Output Delays

1

APPENDIX A PORTS LISTED BY ADDRESS

| Port Address (HEX) | Description |
|-----------------------|---|
| 00 | Read/Write DMA Channel 0 Target Address, A0–A15 |
| 01 | Read/Write DMA Channel 0 Byte Count, B0–B15 |
| 02 | Read/Write DMA Channel 1 Target Address, A0–A15 |
| 03 | Read/Write DMA Channel 1 Byte Count, B0–B15 |
| 04 | Read/Write DMA Channel 2 Target Address, A0–A15 |
| 05 | Read/Write DMA Channel 2 Byte Count, B0–B15 |
| 06 | Read/Write DMA Channel 3 Target Address, A0–A15 |
| 07 | Read/Write DMA Channel 3 Byte Count, B0–B15 |
| 08 | Read/Write DMA Channel 0–3 Status/Command I Register |
| 09 | Read/Write DMA Channel 0–3 Software Request Register |
| 0A | Write DMA Channel 0–3 Set-Reset Mask Register |
| 0B | Write DMA Channel 0–3 Mode Register I |
| 0C | Write Clear Byte-Pointer FF |
| 0D | Write DMA Master-Clear |
| 0E | Write DMA Channel 0–3 Clear Mask Register |
| 0F | Read/Write DMA Channel 0–3 Mask Register |
| 10 | Intel Reserved |
| 11 | Read/Write DMA Channel 0 Byte Count, B16–B23 |
| 12 | Intel Reserved |
| 13 | Read/Write DMA Channel 1 Byte Count, B16–B23 |
| 14 | Intel Reserved |
| 15 | Read/Write DMA Channel 2 Byte Count, B16–B23 |
| 16 | Intel Reserved |
| 17 | Read/Write DMA Channel 3 Byte Count, B16–B23 |
| 18 | Write DMA Channel 0–3 Bus Size Register |
| 19 | Read/Write DMA Channel 0–3 Chaining Register |
| 1A | Write DMA Channel 0–3 Command Register II |
| 1B | Write DMA Channel 0–3 Mode Register II |
| 1C | Read/Write Refresh Control Register |
| 1E | Reset Software Request Interrupt |
| 20 | Write Bank B ICW1, OCW2 or OCW3 Read Bank B Poll, Interrupt Request or In-Service Status Register |
| 21 | Write Bank B ICW2, ICW3, ICW4 or OCW1 Read Bank B Interrupt Mask Register |
| 22 | Read Bank B ICW2 |
| 28 | Read/Write IRQ8 Vector Register |
| 29 | Read/Write IRQ9 Vector Register |
| 2A | Reserved |

| Port Address (HEX) | Description |
|-----------------------|---|
| 2B | Read/Write IRQ11 Vector Register |
| 2C | Read/Write IRQ12 Vector Register |
| 2D | Read/Write IRQ13 Vector Register |
| 2E | Read/Write IRQ14 Vector Register |
| 2F | Read/Write IRQ15 Vector Register |
| 30 | Write Bank A ICW1, OCW2 or OCW3 |
| | Read Bank A Poll, Interrupt Request or In-Service Status Register |
| 31 | Write Bank A ICW2, ICW3, ICW4 or OCW1 |
| | Read Bank A Interrupt Mask Register |
| 32 | Read Bank A ICW2 |
| 38 | Read/Write IRQ0 Vector Register |
| 39 | Read/Write IRQ1 Vector Register |
| 3A | Read/Write IRQ1.5 Vector Register |
| 3B | Read/Write IRQ3 Vector Register |
| 3C | Read/Write IRQ4 Vector Register |
| 3D | Reserved |
| 3E | Reserved |
| 3F | Read/Write IRQ7 Vector Register |
| 40 | Read/Write Counter 0 Register |
| 41 | Read/Write Counter 1 Register |
| 42 | Read/Write Counter 2 Register |
| 43 | Write Control Word Register I—Counter 0, 1, 2 |
| 44 | Read/Write Counter 3 Register |
| 45 | Reserved |
| 46 | Reserved |
| 47 | Write Word Register II—Counter 3 |
| 61 | Write Internal Control Port |
| 64 | Write CPU Reset Register (Data—1111XXX0H) |
| 72 | Read/Write Wait State Register 0 |
| 73 | Read/Write Wait State Register 1 |
| 74 | Read/Write Wait State Register 2 |
| 75 | Read/Write Refresh Wait State Register |
| 76 | Reserved |
| 77 | Reserved |
| 7D | Reserved |
| 7E | Reserved |
| 7F | Read/Write Relocation Register |
| 80 | Read/Write Internal Diagnostic Port 0 |
| 81 | Read/Write DMA Channel 2 Target Address, A16–A23 |
| 82 | Read/Write DMA Channel 3 Target Address, A16–A23 |
| 83 | Read/Write DMA Channel 1 Target Address, A16–A23 |
| 87 | Read/Write DMA Channel 0 Target Address, A16–A23 |
| 88 | Read/Write Internal Diagnostic Port 1 |
| 89 | Read/Write DMA Channel 6 Target Address, A16–A23 |
| 8A | Read/Write DMA Channel 7 Target Address, A16–A23 |
| 8B | Read/Write DMA Channel 5 Target Address, A16–A23 |
| 8F | Read/Write DMA Channel 4 Target Address, A16–A23 |

| Port Address (HEX) | Description |
|-----------------------|---|
| 90 | Read/Write DMA Channel 0 Requester Address, A0–A15 |
| 91 | Read/Write DMA Channel 0 Requester Address, A16–A23 |
| 92 | Read/Write DMA Channel 1 Requester Address, A0–A15 |
| 93 | Read/Write DMA Channel 1 Requester Address, A16–A23 |
| 94 | Read/Write DMA Channel 2 Requester Address, A0–A15 |
| 95 | Read/Write DMA Channel 2 Requester Address, A16–A23 |
| 96 | Read/Write DMA Channel 3 Requester Address, A0–A15 |
| 97 | Read/Write DMA Channel 3 Requester Address, A16–A23 |
| 98 | Read/Write DMA Channel 4 Requester Address, A0–A15 |
| 99 | Read/Write DMA Channel 4 Requester Address, A16–A23 |
| 9A | Read/Write DMA Channel 5 Requester Address, A0–A15 |
| 9B | Read/Write DMA Channel 5 Requester Address, A16–A23 |
| 9C | Read/Write DMA Channel 6 Requester Address, A0–A15 |
| 9D | Read/Write DMA Channel 6 Requester Address, A16–A23 |
| 9E | Read/Write DMA Channel 7 Requester Address, A0–A15 |
| 9F | Read/Write DMA Channel 7 Requester Address, A16–A23 |
| A0 | Write Bank C ICW1, OCW2 or OCW3 Read Bank C Poll, Interrupt Request or In-Service Status Register |
| A1 | Write Bank C ICW2, ICW3, ICW4 or OCW1 Read Bank C Interrupt Mask Register |
| A2 | Read Bank C ICW2 |
| A8 | Read/Write IRQ16 Vector Register |
| A9 | Read/Write IRQ17 Vector Register |
| AA | Read/Write IRQ18 Vector Register |
| AB | Read/Write IRQ19 Vector Register |
| AC | Read/Write IRQ20 Vector Register |
| AD | Read/Write IRQ21 Vector Register |
| AE | Read/Write IRQ22 Vector Register |
| AF | Read/Write IRQ23 Vector Register |
| C0 | Read/Write DMA Channel 4 Target Address, A0–A15 |
| C1 | Read/Write DMA Channel 4 Byte Count, B0–B15 |
| C2 | Read/Write DMA Channel 5 Target Address, A0–A15 |
| C3 | Read/Write DMA Channel 5 Byte Count, B0–B15 |
| C4 | Read/Write DMA Channel 6 Target Address, A0–A15 |
| C5 | Read/Write DMA Channel 6 Byte Count, B0–B15 |
| C6 | Read/Write DMA Channel 7 Target Address, A0–A15 |
| C7 | Read/Write DMA Channel 7 Byte Count, B0–B15 |
| C8 | Read DMA Channel 4–7 Status/Command i Register |
| C9 | Read/Write DMA Channel 4–7 Software Request Register |
| CA | Write DMA Channel 4–7 Set-Reset Mask Register |
| CB | Write DMA Channel 4–7 Mode Register i |
| CC | Reserved |
| CD | Reserved |
| CE | Write DMA Channel 4–7 Clear Mask Register |
| CF | Read/Write DMA Channel 4–7 Mask Register |
| D0 | Intel Reserved |
| D1 | Read/Write DMA Channel 4 Byte Count, B16–B23 |
| D2 | Intel Reserved |
| D3 | Read/Write DMA Channel 5 Byte Count, B16–B23 |

| Port Address (HEX) | Description |
|-----------------------|--|
| D4 | Intel Reserved |
| D5 | Read/Write DMA Channel 6 Byte Count, B16-B23 |
| D6 | Intel Reserved |
| D7 | Read/Write DMA Channel 7 Byte Count, B16-B23 |
| D8 | Write DMA Channel 4-7 Bus Size Register |
| D9 | Read/Write DMA Channel 4-7 Chaining Register |
| DA | Write DMA Channel 4-7 Command Register II |
| DB | Write DMA Channel 4-7 Mode Register II |

APPENDIX B PORTS LISTED BY FUNCTION

| Port Address (HEX) | Description |
|-----------------------|--|
| DMA CONTROLLER | |
| 0D | Write DMA Master-Clear |
| 0C | Write DMA Clear Byte-Pointer FF |
| 08 | Read/Write DMA Channel 0-3 Status/Command I Register |
| C8 | Read/Write DMA Channel 4-7 Status/Command I Register |
| 1A | Write DMA Channel 0-3 Command Register II |
| DA | Write DMA Channel 4-7 Command Register II |
| 0B | Write DMA Channel 0-3 Mode Register I |
| CB | Write DMA Channel 4-7 Mode Register I |
| 1B | Write DMA Channel 0-3 Mode Register II |
| DB | Write DMA Channel 4-7 Mode Register II |
| 09 | Read/Write DMA Channel 0-3 Software Request Register |
| C9 | Read/Write DMA Channel 4-7 Software Request Register |
| 1E | Reset Software Request Interrupt |
| 0E | Write DMA Channel 0-3 Clear Mask Register |
| CE | Write DMA Channel 4-7 Clear Mask Register |
| 0F | Read/Write DMA Channel 0-3 Mask Register |
| CF | Read/Write DMA Channel 4-7 Mask Register |
| 0A | Write DMA Channel 0-3 Set-Reset Mask Register |
| CA | Write DMA Channel 4-7 Set-Reset Mask Register |
| 18 | Write DMA Channel 0-3 Bus Size Register |
| D8 | Write DMA Channel 4-7 Bus Size Register |
| 19 | Read/Write DMA Channel 0-3 Chaining Register |
| D9 | Read/Write DMA Channel 4-7 Chaining Register |
| 00 | Read/Write DMA Channel 0 Target Address, A0-A15 |
| 87 | Read/Write DMA Channel 0 Target Address, A16-A23 |
| 01 | Read/Write DMA Channel 0 Byte Count, B0-B15 |
| 11 | Read/Write DMA Channel 0 Byte Count, B16-B23 |
| 90 | Read/Write DMA Channel 0 Requester Address, A0-A15 |
| 91 | Read/Write DMA Channel 0 Requester Address, A16-A23 |

| Port Address (HEX) | Description |
|-----------------------------------|---|
| DMA CONTROLLER (Continued) | |
| 02 | Read/Write DMA Channel 1 Target Address, A0–A15 |
| 83 | Read/Write DMA Channel 1 Target Address, A16–A23 |
| 03 | Read/Write DMA Channel 1 Byte Count, B0–B15 |
| 13 | Read/Write DMA Channel 1 Byte Count, B16–B23 |
| 92 | Read/Write DMA Channel 1 Requester Address, A0–A15 |
| 93 | Read/Write DMA Channel 1 Requester Address, A16–A23 |
| 04 | Read/Write DMA Channel 2 Target Address, A0–A15 |
| 81 | Read/Write DMA Channel 2 Target Address, A16–A23 |
| 05 | Read/Write DMA Channel 2 Byte Count, B0–B15 |
| 15 | Read/Write DMA Channel 2 Byte Count, B16–B23 |
| 94 | Read/Write DMA Channel 2 Requester Address, A0–A15 |
| 95 | Read/Write DMA Channel 2 Requester Address, A16–A23 |
| 06 | Read/Write DMA Channel 3 Target Address, A0–A15 |
| 82 | Read/Write DMA Channel 3 Target Address, A16–A23 |
| 07 | Read/Write DMA Channel 3 Byte Count, B0–B15 |
| 17 | Read/Write DMA Channel 3 Byte Count, B16–B23 |
| 96 | Read/Write DMA Channel 3 Requester Address, A0–A15 |
| 97 | Read/Write DMA Channel 3 Requester Address, A16–A23 |
| C0 | Read/Write DMA Channel 4 Target Address, A0–A15 |
| 8F | Read/Write DMA Channel 4 Target Address, A16–A23 |
| C1 | Read/Write DMA Channel 4 Byte Count, B0–B15 |
| D1 | Read/Write DMA Channel 4 Byte Count, B16–B23 |
| 98 | Read/Write DMA Channel 4 Requester Address, A0–A15 |
| 99 | Read/Write DMA Channel 4 Requester Address, A16–A23 |
| C2 | Read/Write DMA Channel 5 Target Address, A0–A15 |
| 8B | Read/Write DMA Channel 5 Target Address, A16–A23 |
| C3 | Read/Write DMA Channel 5 Byte Count, B0–B15 |
| D3 | Read/Write DMA Channel 5 Byte Count, B16–B23 |
| 9A | Read/Write DMA Channel 5 Requester Address, A0–A15 |
| 9B | Read/Write DMA Channel 5 Requester Address, A16–A23 |
| C4 | Read/Write DMA Channel 6 Target Address, A0–A15 |
| 89 | Read/Write DMA Channel 6 Target Address, A16–A23 |
| C5 | Read/Write DMA Channel 6 Byte Count, B0–B15 |
| D5 | Read/Write DMA Channel 6 Byte Count, B16–B23 |
| 9C | Read/Write DMA Channel 6 Requester Address, A0–A15 |
| 9D | Read/Write DMA Channel 6 Requester Address, A16–A23 |
| C6 | Read/Write DMA Channel 7 Target Address, A0–A15 |
| 8A | Read/Write DMA Channel 7 Target Address, A16–A23 |
| C7 | Read/Write DMA Channel 7 Byte Count, B0–B15 |
| D7 | Read/Write DMA Channel 7 Byte Count, B16–B23 |
| 9E | Read/Write DMA Channel 7 Requester Address, A0–A15 |
| 9F | Read/Write DMA Channel 7 Requester Address, A16–A23 |

| Port Address (HEX) | Description |
|-----------------------------|--|
| INTERRUPT CONTROLLER | |
| 20 | Write Bank B ICW1, OCW2 or OCW3 Read Bank B Poll, Interrupt Request or In-Service Status Register |
| 21 | Write Bank B ICW2, ICW3, ICW4 or OCW1 Read Bank B Interrupt Mask Register |
| 22 | Read Bank B ICW2 |
| 28 | Read/Write IRQ8 Vector Register |
| 29 | Read/Write IRQ9 Vector Register |
| 2A | Reserved |
| 2B | Read/Write IRQ11 Vector Register |
| 2C | Read/Write IRQ12 Vector Register |
| 2D | Read/Write IRQ13 Vector Register |
| 2E | Read/Write IRQ14 Vector Register |
| 2F | Read/Write IRQ15 Vector Register |
| A0 | Write Bank C ICW1, OCW2 or OCW3 Read Bank C Poll, Interrupt Request or In-Service Status Register |
| A1 | Write Bank C ICW2, ICW3, ICW4 or OCW1 Read Bank C Interrupt Mask Register |
| A2 | Read Bank C ICW2 |
| A8 | Read/Write IRQ16 Vector Register |
| A9 | Read/Write IRQ17 Vector Register |
| AA | Read/Write IRQ18 Vector Register |
| AB | Read/Write IRQ19 Vector Register |
| AC | Read/Write IRQ20 Vector Register |
| AD | Read/Write IRQ21 Vector Register |
| AE | Read/Write IRQ22 Vector Register |
| AF | Read/Write IRQ23 Vector Register |
| 30 | Write Bank A ICW1, OCW2 or OCW3 Read Bank A Poll, Interrupt Request or In-Service Status Register |
| 31 | Write Bank A ICW2, ICW3, ICW4 or OCW1 Read Bank A Interrupt Mask Register |
| 32 | Read Bank A ICW2 |
| 38 | Read/Write IRQ0 Vector Register |
| 39 | Read/Write IRQ1 Vector Register |
| 3A | Read/Write IRQ1.5 Vector Register |
| 3B | Read/Write IRQ3 Vector Register |
| 3C | Read/Write IRQ4 Vector Register |
| 3D | Reserved |
| 3E | Reserved |
| 3F | Read/Write IRQ7 Vector Register |

| Port Address (HEX) | Description |
|--|---|
| PROGRAMMABLE INTERVAL TIMER | |
| 40 | Read/Write Counter 0 Register |
| 41 | Read/Write Counter 1 Register |
| 42 | Read/Write Counter 2 Register |
| 43 | Write Control Word Register I—Counter 0, 1, 2 |
| 44 | Read/Write Counter 3 Register |
| 47 | Write Word Register II—Counter 3 |
| CPU RESET | |
| 64 | Write CPU Reset Register (Data—1111XXX0H) |
| WAIT STATE GENERATOR | |
| 72 | Read/Write Wait State Register 0 |
| 73 | Read/Write Wait State Register 1 |
| 74 | Read/Write Wait State Register 2 |
| 75 | Read/Write Refresh Wait State Register |
| DRAM REFRESH CONTROLLER | |
| 1C | Read/Write Refresh Control Register |
| INTERNAL CONTROL AND DIAGNOSTIC PORTS | |
| 61 | Write Internal Control Port |
| 80 | Read/Write Internal Diagnostic Port 0 |
| 88 | Read/Write Internal Diagnostic Port 1 |
| RELOCATION REGISTER | |
| 7F | Read/Write Relocation Register |
| INTEL RESERVED PORTS | |
| 10 | Reserved |
| 12 | Reserved |
| 14 | Reserved |
| 16 | Reserved |
| 2A | Reserved |
| 3D | Reserved |
| 3E | Reserved |
| 45 | Reserved |
| 46 | Reserved |
| 76 | Reserved |
| 77 | Reserved |
| 7D | Reserved |
| 7E | Reserved |
| CC | Reserved |
| CD | Reserved |
| D0 | Reserved |
| D2 | Reserved |
| D4 | Reserved |
| D6 | Reserved |

APPENDIX C SYSTEM NOTES

1. BHE # IN MASTER MODE.

In Master Mode, BHE # will be activated during DMA to/from 8-bit devices residing at even locations when the remaining byte count is greater than 1.

For example, if an 8-bit device is located at 00000000 Hex and the number of bytes to be transferred is > 1, the first address/BHE # combination will be 00000000/0. In some systems this will cause the bus controller to perform two 8-bit accesses, the first to 00000000 Hex and the second to 00000001 Hex. However, the 82370's DMA will only read/write one byte. This may or may not cause a problem in the system depending on what is located at 00000001 Hex.

Solution:

There are two solutions if BH# active is unacceptable. Of the two, number 2 is the cleanest and most recommended.

1. If there is an 8-bit device that uses DMA located at an even address, do not use that address + 1. The limitation of this solution is that the user must have complete control over what addresses will be used in the end system.
2. Do not allow the Bus Controller to split cycles for the DMA.

82370 TIMER UNIT NOTES

The 82370 DMA Controller with Integrated System Peripherals is functionally inconsistent with the data sheet. This document explains the behavior of the 82370 Timer Unit and outlines subsequent limitations of the timer unit. This document also provides recommended workarounds.

1.0 WRITE CYCLES TO THE 82370 TIMER UNIT:

This errata applies only to SLAVE WRITE cycles to the 82370 timer unit. During these cycles, the data being written into the 82370 timer unit may be corrupted if asynchronous CLKIN is not inhibited during a certain "window" of the write cycle.

1.1 Description

Please refer to Figure C-2.

During write cycles to the 82370 timer unit, the 82370 translates the 80376 interface signals such as #ADS, #W/R, #M/IO, and #D/C into several internal signals that control the operation of the internal sub-blocks (e.g. Timer Unit).

The 82370 timer unit is controlled by such internal signals. These internal signals are generated and sampled with respect to two separate clock signals: CLK2 (the system clock) and CLKIN (the 82370 timer unit clock).

Since the CLKIN and CLK2 clock signals are used internally to generate control signals for the interface to the timer unit, some timing parameters must be met in order for the interface logic to function properly.

Those timing parameters are met by inhibiting the CLKIN signal for a specific window during Write Cycles to the 82370 Timer Unit.

The CLKIN signal must be inhibited using external logic, as the GATE function of the 82370 timer unit is not guaranteed to totally inhibit CLKIN.

1.2 Consequences

This CLKIN inhibits circuitry guarantees proper write cycles to the 82370 timer unit.

Without this solution, write cycles to the 82370 timer unit could place corrupted data into the timer unit registers. This, in turn, could yield inaccurate results and improper timer operation.

The proposed solution would involve a hardware modification for existing systems.

1.3 Solution

A timing waveform (Figure C-3) shows the specific window during which CLKIN must be inhibited. Please note that CLKIN must only be inhibited during the window shown in Figure C-3. This window is defined by two AC timing parameters:

$$t_a = 9 \text{ ns}$$

$$t_b = 28 \text{ ns}$$

The proposed solution provides a certain amount of system "guardband" to make sure that this window is avoided.

PAL equations for a suggested workaround are also included. Please refer to the comments in the PAL codes for stated assumptions of this particular workaround. A state diagram (Figure C-4) is provided to help clarify how this PAL is designed.

Figure C-5 shows how this PAL would fit into a system workaround. In order to show the effect of this workaround on the CLKIN signal, Figure C-6 shows how CLKIN is inhibited. Note that you must still meet the CLKIN AC timing parameters (e.g. t_{47} (min), t_{48} (min)) in order for the timer unit to function properly.

Please note that this workaround has not been tested. It is provided as a suggested solution. Actual solutions will vary from system to system.

1

1.4 Long Term Plans

Intel has no plans to fix this behavior in the 82370 timer unit.

```
module Timer_82370_Fix
flag '-r2', '-q2', '-f1', '-t4', '-w1,3,6,5,4,16,7,12,17,18,15,14'
title '82370 Timer Unit CLKIN
      INHIBIT signal PAL Solution '
Timer_Unit_Fix device 'P16R6';
```

"This PAL inhibits the CLKIN signal (that comes from an oscillator)
"during Slave Writes to the 82370 Timer unit.
"

"ASSUMPTION: This PAL assumes that an external system address
"decoder provides a signal to indicate that an 82370
"Timer Unit access is taking place. This input
"signal is called TMR in this PAL. This PAL also
"assumes that this TMR signal occurs during a
"specific T-State. Please see Figure 2 of this
"document to see when this signal is expected to
"be active by this PAL.
"

"NOTE: This PAL does not support pipelined 82370 SLAVE
"cycles.
"

"(c) Intel Corporation 1989. This PAL is provided as a proposed
"method of solving a certain 82370 Timer Unit problem. This PAL
"has not been tested or validated. Please validate this solution
"for your system and application.
"

"Input Pins"

| | | |
|----------|-----|--|
| CLK2 | pin | 1; "System Clock |
| RESET | pin | 2; "Microprocessor RESET signal |
| TMR | pin | 3; "Input from Address Decoder, indicating "an access to the timer unit of the "82370. |
| IRDY | pin | 4; "End of Cycle indicator |
| IADS | pin | 5; "Address and control strobe |
| CLK | pin | 6; "PHI2 clock |
| W_R | pin | 7; "Write/Read Signal" |
| nc1 | pin | 8; "No Connect 0" |
| nc3 | pin | 9; "No Connect 1" |
| GNDA | pin | 10; "Tied to ground, documentation only |
| GNDB | pin | 11; "Output enable, documentation only |
| CLKIN_IN | pin | 12; "Input-CLKIN directly from oscillator |

"Output Pins"

| | | |
|-----------|-----|---|
| Q_0 | pin | 18; "Internal signal only, fed back to "PAL logic" |
| CLKIN_OUT | pin | 17; "CLKIN signal fed to 82370 Timer Unit |
| INHIBIT | pin | 16; "CLKIN Inhibit signal |
| SO | pin | 15; "Unused State Indicator Pin |
| S1 | pin | 14; "Unused State Indicator Pin |

"Declarations"

```
Valid_ADS = ADS & CLK ; "#ADS sampled in PH11 of 80376 T-State
Valid_RDY = RDY & CLK ; "#RDY sampled in PH11 of 80376 T-State
Timer_Acc = TMR & CLK ; "Timer Unit Access, as provided by
                    "external Address Decoder"
```

State_Diagram [INHIBIT, S1, S0]

```
state 000:      if RESET then 000
                 else if Valid_ADS & W_R then 001
                 else 000;

state 001:      if RESET then 000
                 else if Timer_Acc then 010
                 else if !Timer_Acc then 000
                 else 001;

state 010:      if RESET then 000
                 else if CLK then 110
                 else 010;

state 110:      if RESET then 000
                 else if CLK then 111
                 else 110;

state 111:      if RESET then 000
                 else if CLK then 011
                 else 111;

state 011:      if RESET then 000
                 else if Valid_RDY then 000
                 else 011;

state 100:      if RESET then 000
                 else 000;

state 101:      if RESET then 000
                 else 000;
```

EQUATIONS

```
Q_0 := CLKIN_IN; "Latched incoming clock. This signal is used
                 "internally to feed into the MUX-ing logic"
```

```
CLKIN_OUT := (INHIBIT & CLKIN_OUT & !RESET)
             +(!INHIBIT & Q_0 & !RESET);
```

```
"Equation for CLKIN_OUT. This
"feeds directly to the 82370 Timer Unit."
```

END

1

82370 Timer Unit CLKIN
 INHIBIT signal PAL Solution
 Equations for Module Timer__82370__Fix

Device Timer__Unit__Fix

—Reduced Equations:

```
!!INHIBIT := (ICLK & !!INHIBIT # CLK & S0 # RESET # !S1);
```

```
IS1 := (RESET
# INHIBIT & IS1
# CLK & !!INHIBIT & !~RDY & S0 & S1
# ICLK & IS1
# IS1 & !TMR
# IS0 & IS1);
```

```
IS0 := (RESET
# INHIBIT & IS1
# CLK & !!INHIBIT & !~RDY & S1
# !!INHIBIT & IS0 & S1
# ICLK & IS0
# !!INHIBIT & !S0 & S1
# S0 & IS1
# IS1 & !W__R
# ~ADS & !S1);
```

```
IQ_0 := (ICLKIN_IN);
```

```
ICLKIN_OUT := (RESET # !CLKIN_OUT & INHIBIT # !!INHIBIT & IQ_0);
```

82370 Timer Unit CLKIN
 INHIBIT signal PAL Solution
 Chip diagram for Module Timer_82370_Fix

Device Timer_Unit_Fix

P16R6

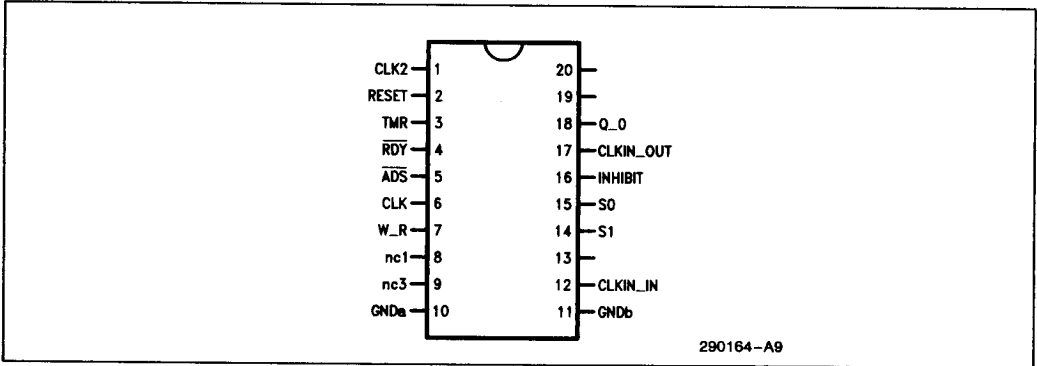

1

end of module Timer_82370_Fix

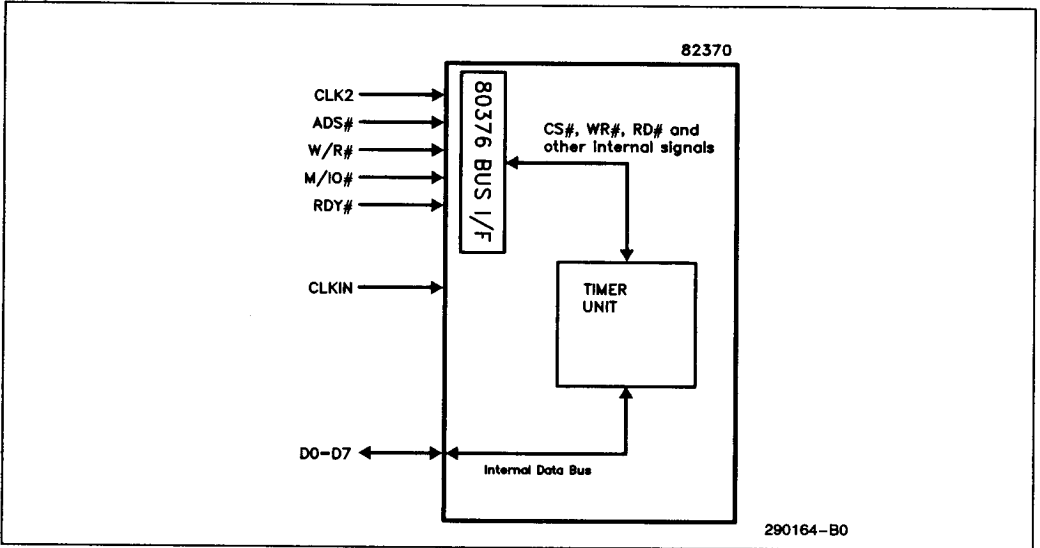

Figure C-2. Translation of 80376 Signals to Internal 82370 Timer Unit Signals

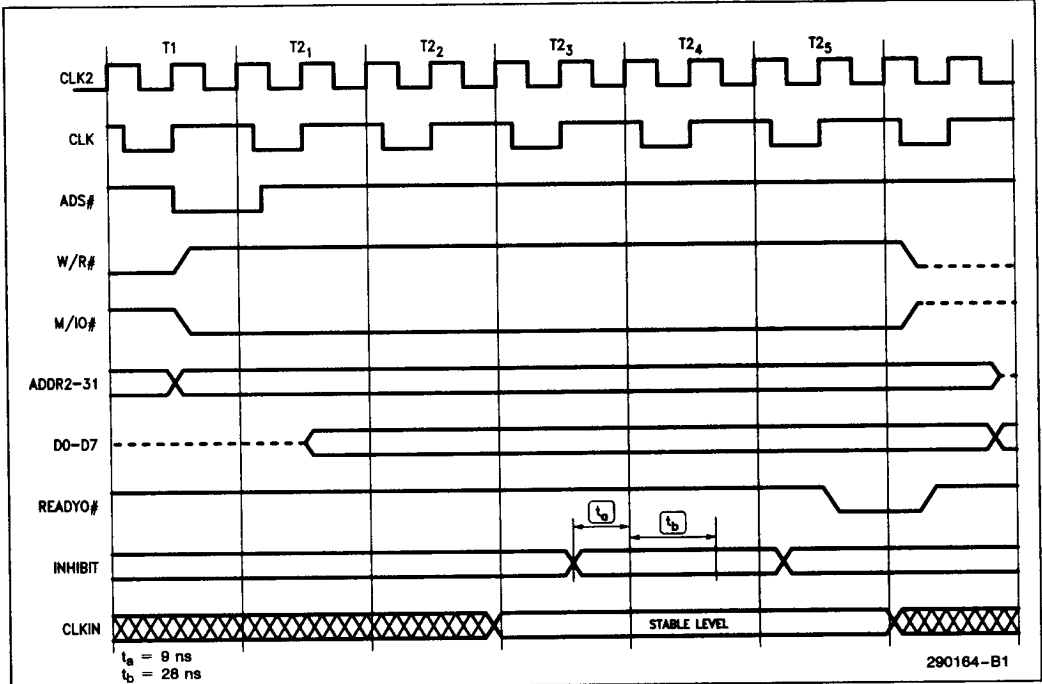

Figure C-3. 82370 Timer Unit Write Cycle

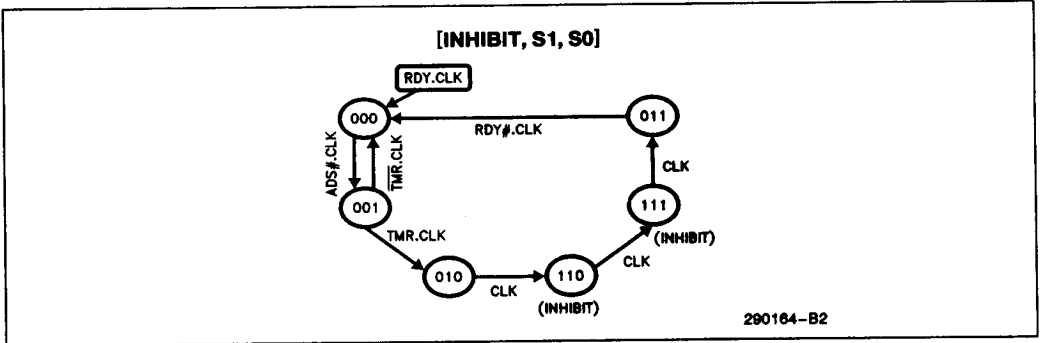

Figure C-4. State Diagram for Inhibit Signal

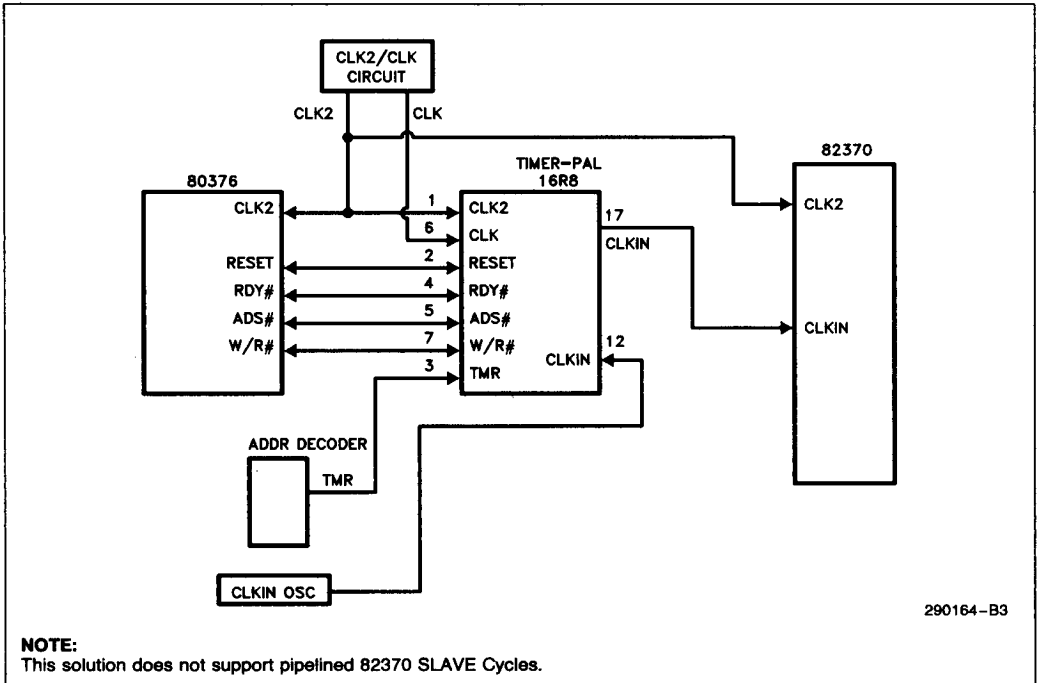

Figure C-5. System with 82370 Timer Unit "INHIBIT" Circuitry

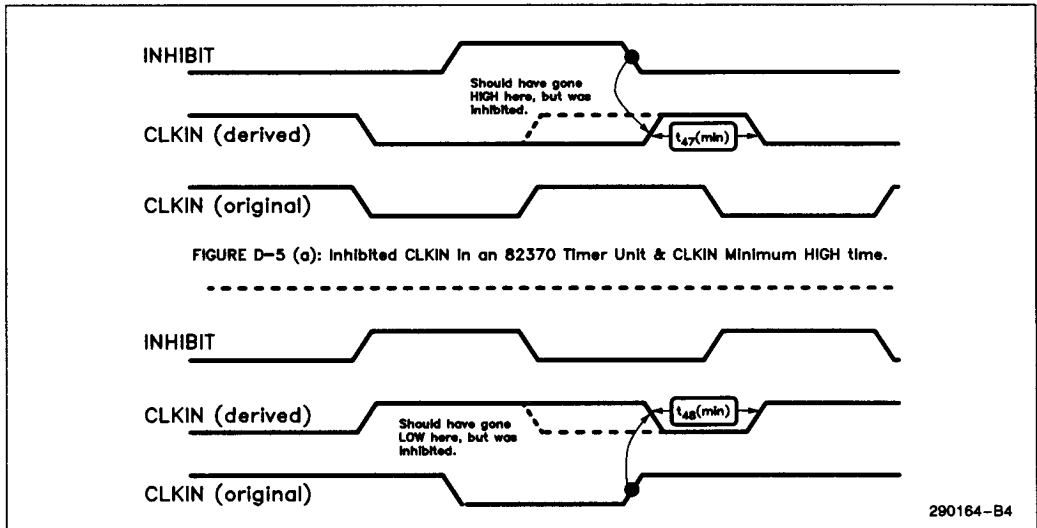

Figure C-6. Inhibited CLKIN in an 82370 Timer Unit and CLKIN Minimum LOW Time