

PAGE 1/3	ISSUE 1427A	SERIES <b>SMC</b>	PART NUMBER <b>R112005000</b>
----------	-------------	-------------------	-------------------------------

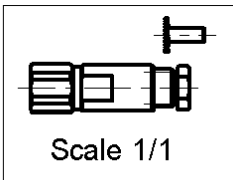

All dimensions are in mm.

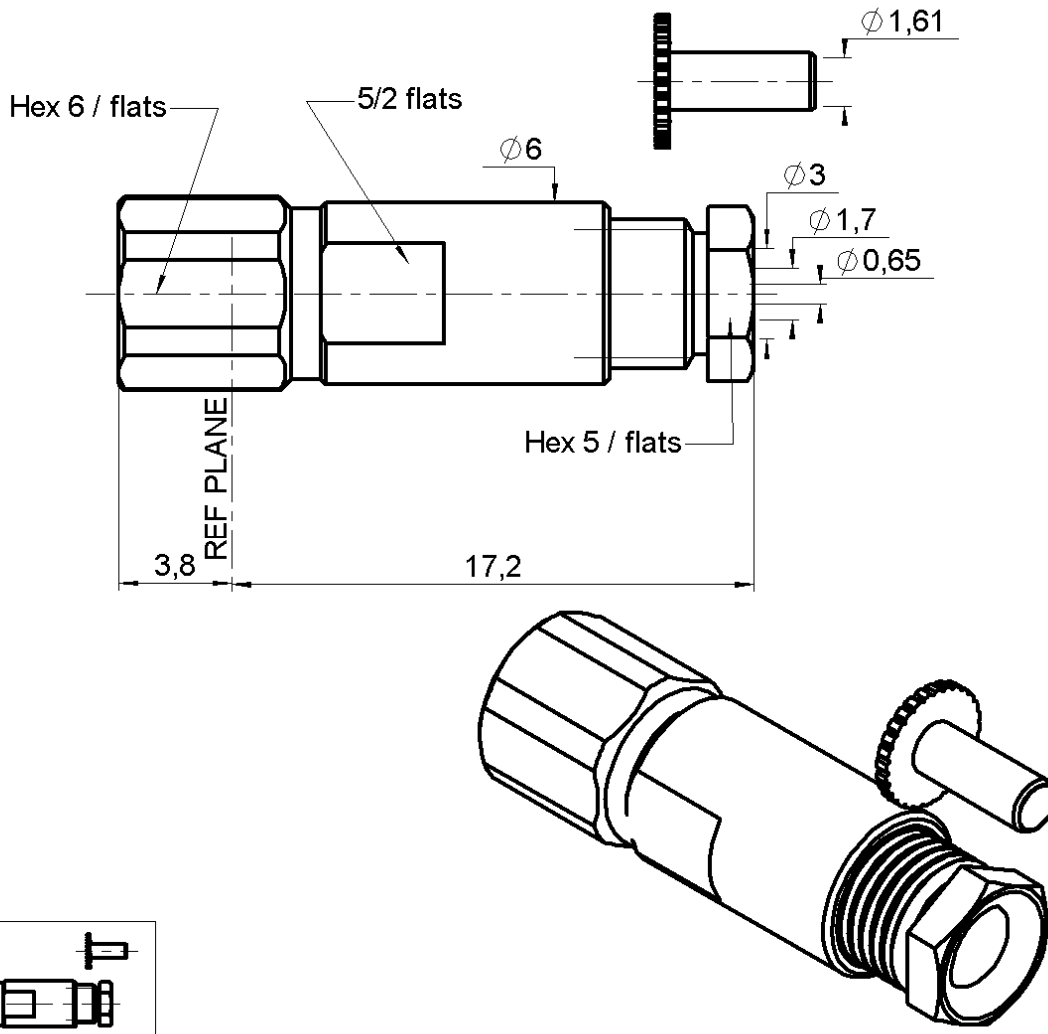
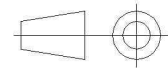

COMPONENTS	MATERIALS	PLATING (µm)
Body	<b>BRASS</b>	<b>GOLD 0.2 OVER NICKEL 2</b>
Center contact	<b>BERYLLIUM COPPER</b>	<b>GOLD 1.3 OVER NICKEL2</b>
Outer contact	-	-
Insulator	<b>PTFE</b>	
Gasket	<b>CHLOROPRENE</b>	
Others parts	<b>BRASS</b>	<b>GOLD 0.2 OVER NICKEL 2</b>
-	-	-
-	-	-

PAGE <b>2/3</b>	ISSUE <b>1427A</b>	SERIES <b>SMC</b>	PART NUMBER <b>R112005000</b>
-----------------	--------------------	-------------------	-------------------------------

### PACKAGING

Standard	Unit	Other
<b>100</b>	<b>Contact us</b>	<b>Contact us</b>

### ELECTRICAL CHARACTERISTICS

Impedance	<b>50</b>	Ω
Frequency	<b>0-10</b>	GHz
VSWR	<b>1.20 + 0,0400</b>	x F(GHz) Maxi
Insertion loss	<b>0.125</b>	√F(GHz) dB Maxi
RF leakage	- ( <b>62</b> )	- F(GHz) dB Maxi
Voltage rating	<b>335</b>	Veff Maxi
Dielectric withstanding voltage	<b>1000</b>	Veff mini
Insulation resistance	<b>1000</b>	MΩ mini

### MECHANICAL CHARACTERISTICS

Center contact retention		
Axial force – Mating End	<b>10</b>	N mini
Axial force – Opposite end	<b>10</b>	N mini
Torque	<b>NA</b>	N.cm mini
Recommended torque		
Mating	<b>30</b>	N.cm
Panel nut	<b>NA</b>	N.cm
Clamp nut	<b>70</b>	N.cm
A/F clamp nut	<b>5,0000</b>	mm
Mating life	<b>500</b>	Cycles mini
Weight	<b>2,8000</b>	g

### ENVIRONMENTAL

Operating temperature	<b>-65/+165</b>	°C
Hermetic seal	<b>NA</b>	Atm.cm3/s
Panel leakage	<b>NA</b>	

### SPECIFICATION

### CABLE ASSEMBLY

Stripping	a	b	c	d	e	f
mm	<b>2,5</b>	<b>1,2</b>	<b>4,5</b>	<b>4,5</b>	<b>0</b>	<b>0</b>

Assembly instruction:

Recommended cable(s)

**RG 179**  
**RG 187**  
**RG 188**  
**KX 22A**  
**RG 316**

Characteristics indicated on this data sheet are those that can be achieved with the highest performance cable. Intrinsic limitations of the cable may diminish the performance of the assembly

Cable retention

- pull off	<b>110</b>	N mini
- torque	<b>NA</b>	N.cm

### TOOLING

Part Number	Description	Hexagon
.	.	.

### OTHER CHARACTERISTICS

-

PAGE 3/3	ISSUE 1427A	SERIES SMC	PART NUMBER R112005000
----------	-------------	------------	------------------------

**COMPONENTS**

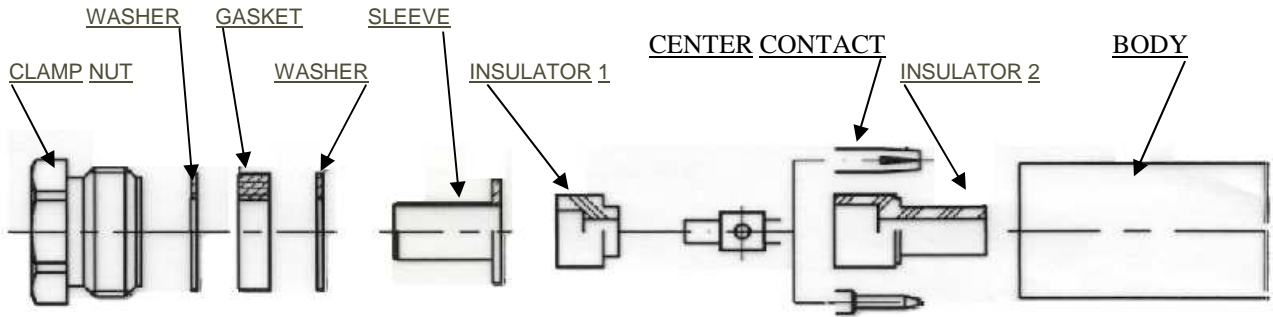

1

- Mount clamp nut, washer, flat gasket, washer.
- Strip the cable, make 2 slits 180° apart in the sheath.

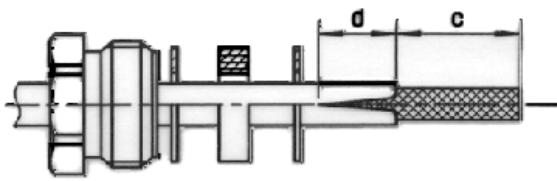

3

- Mount the insulator 1
- Mount the center contact and solder.
- Mount the insulator.2

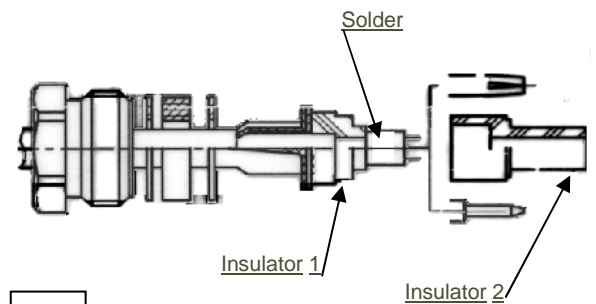

2

- Mount the braid-clamp.
- (for cable 2.6/50 use knurled clamp , for cable 2.6/75 use smooth clamp.
- Cut braid flush Ø of braid clamp.
- Strip off the dielectric.

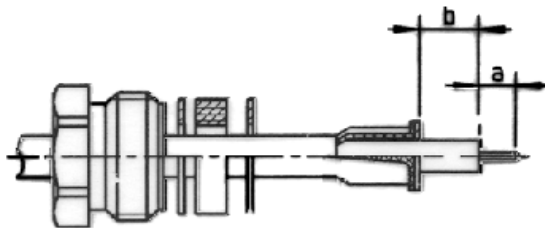

4

- Screw the cable assembly into the body.
- Recommended coupling torque 70 Ncm (Recommended tool R282.321.010).

