

PAGE 1/3	ISSUE 06-04-16B	SERIES BMA	PART NUMBER R128053201
----------	-----------------	------------	------------------------

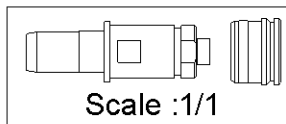

All dimensions are in mm.

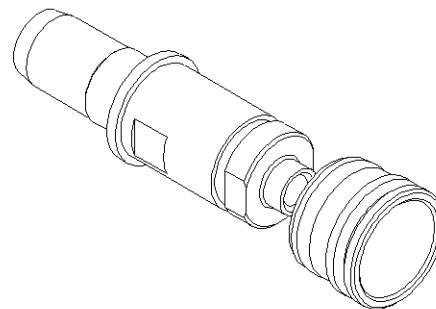
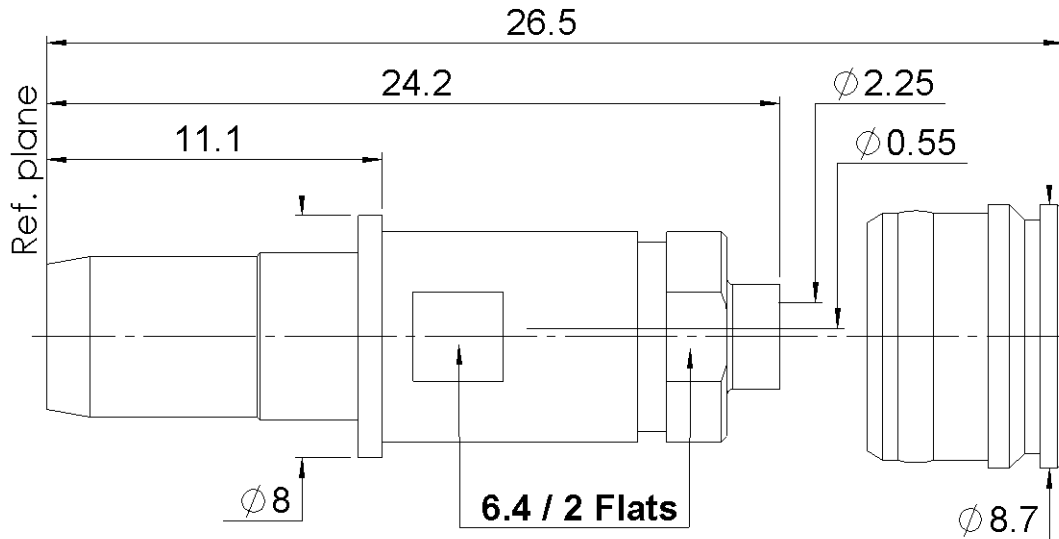
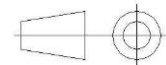

COMPONENTS	MATERIALS	PLATING (µm)
Body	STAINLESS STEEL	PASSIVATED.
Center contact	BRASS	-
Outer contact	-	PASSIVATED.
Insulator	PTFE	
Gasket	-	
Others parts	BRASS	
-	-	-
-	-	-

PAGE 2/3	ISSUE 06-04-16B	SERIES BMA	PART NUMBER R128053201
-----------------	------------------------	-------------------	-------------------------------

PACKAGING

Standard	Unit	Other
100	Contact us	Contact us

ELECTRICAL CHARACTERISTICS

Impedance	50	Ω
Frequency	0-18	GHz
VSWR	1.07 + 0,0100	x F(GHz) Maxi
Insertion loss	0.03	\sqrt{F} (GHz) dB Maxi
RF leakage	- (NA)	- F(GHz)) dB Maxi
Voltage rating	350	Veff Maxi
Dielectric withstanding voltage	1000	Veff mini
Insulation resistance	5000	M Ω mini

MECHANICAL CHARACTERISTICS

Center contact retention		
Axial force – Mating End	27	N mini
Axial force – Opposite end	27	N mini
Torque	NA	N.cm mini
Recommended torque		
Mating	NA	N.cm
Panel nut	NA	N.cm
Clamp nut	200	N.cm
A/F clamp nut	6,4000	mm
Mating life	1000	Cycles mini
Weight	4,3000	g

ENVIRONMENTAL

Operating temperature	-65/+125	$^{\circ}\text{C}$
Hermetic seal	NA	Atm.cm3/s
Panel leakage	NA	

SPECIFICATION

CABLE ASSEMBLY

Stripping	a	b	c	d	e	f
mm	0	3,17	0	0	0	0

Assembly instruction:

Recommended cable(s)

RG 405
KS 1

Characteristics indicated on this data sheet are those that can be achieved with the highest performance cable. Intrinsic limitations of the cable may diminish the performance of the assembly

Cable retention

- pull off	136	N mini
- torque	NA	N.cm

TOOLING

Part Number	Description	Hexagon
.	.	.

OTHER CHARACTERISTICS

-

PAGE 3/3	ISSUE 06-04-16B	SERIES BMA	PART NUMBER R128053201
----------	-----------------	------------	------------------------

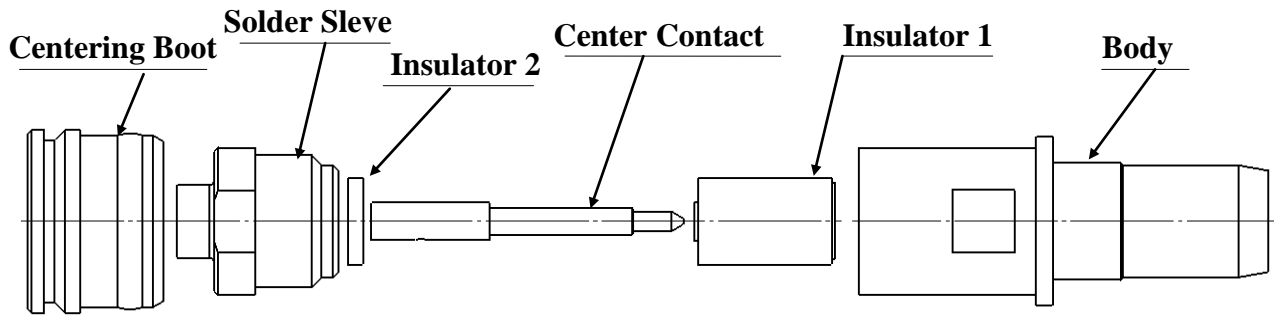

We recommend a cable thermal preconditioning before assembly

<p>1°</p> <p>To take the tool kit: R282.120.000 Strip the dielectric of the cable Stripping tool cable: R282.051.000 Trim cable centre conductor Trimmer: R282.063.000 Clean the cable.</p>	<table border="1"> <thead> <tr> <th>Stripping</th> <th>a</th> <th>b</th> <th>c</th> <th>d</th> <th>e</th> </tr> </thead> <tbody> <tr> <td>Inch</td> <td>0</td> <td>0.125</td> <td>0</td> <td>0</td> <td>0</td> </tr> <tr> <td>Mm</td> <td>0</td> <td>3.17</td> <td>0</td> <td>0</td> <td>0</td> </tr> </tbody> </table>	Stripping	a	b	c	d	e	Inch	0	0.125	0	0	0	Mm	0	3.17	0	0	0
Stripping	a	b	c	d	e														
Inch	0	0.125	0	0	0														
Mm	0	3.17	0	0	0														
<p>2°</p> <p>Slide the solder sleeve onto the cable Position solder sleeve flush against solder barrel gauge and solder to the cable or align with outer the connector (b). Solder barrel gauge: R282.744.300</p>																			
<p>3°</p> <p>Once cooled, remove the solder barrel gauge. Cut the dielectric flush to clamp braid sleeve. Slide the insulator onto the cable inner conductor. Slide the insulator onto the cable inner conductor against insulator. Fit the cable assembly onto the soldering jig R282.740.000 and the positioner R282.744.220 Tighten cable and solder the center contact.</p>																			
<p>4°</p> <p>Insulator way assembly: big flange coincident with body and little flange coincident with center contact.</p>																			
<p>5°</p> <p>Screw sub-assembly into the connector body. (Recommended coupling torque 17.7 in.lb) *0.248/2flats on Solder too</p>																			