

DESCRIPTION

The EV2605DQ-00B is an evaluation board for the MP2605, a linear, high-performance single cell Li-Ion battery charger.

By integrating high voltage input protection into the charger IC, the MP2605 can tolerate an input surge up to 28V.

The MP2605 features constant current (CC) and constant voltage (CV) charging modes with programmable charge currents (200mA to 1A), Time out control battery full terminated control, thermal protection, battery temperature monitoring, reverse current blocking and trickle charge. The device also provides AC adapter power good and charge status indications to the system.

ELECTRICAL SPECIFICATION

Parameter	Symbol	Value	Units
Input Voltage	V_{IN}	5	V
Charge Current	I_{CHG}	0.8	A

FEATURES

- Input Surge up to 28V
- Adapter or USB Input
- Programmable Charge Current: 200mA to 1A
- Proprietary Over-Voltage Protection
- 0.75% V_{BATT} Accuracy
- Battery Temperature Monitoring
- AC Adapter Power Good Indicator
- Charge Status Indicator
- Battery full terminated control
- Timer off control
- Fully Assembled and Tested

APPLICATIONS

- Cell Phones
- MP3 Players
- Smart Phones
- PDAs
- Digital Cameras

"MPS" and "The Future of Analog IC Technology" are Registered Trademarks of Monolithic Power Systems, Inc.

EV2605DQ-00B EVALUATION BOARD



(L x W x H) 2.0" x 1.9" x 0.5"
(5.0cm x 4.8cm x 1.2cm)

Board Number	MPS IC Number
EV2605DQ-00B	MP2605DQ

I-V Charge Curve

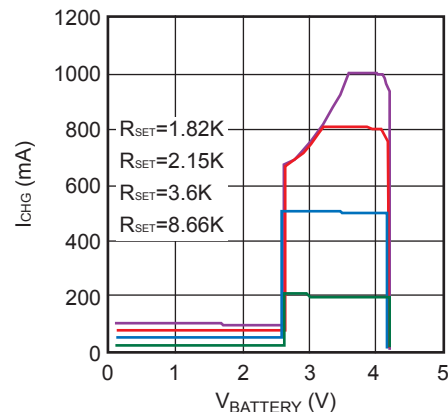

EVALUATION BOARD SCHEMATIC

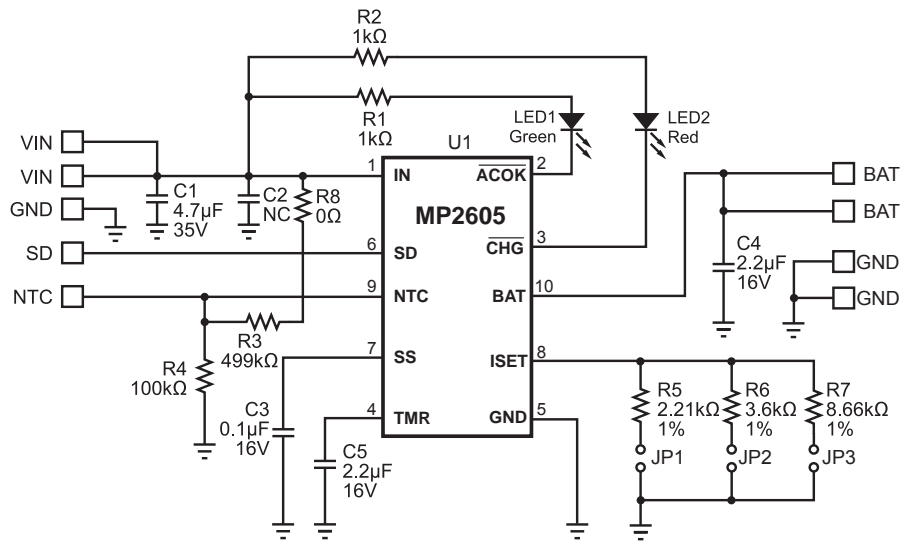

EV2605DQ-00B BILL OF MATERIALS

Qty	Ref	Value	Description	Package	Manufacturer	Manufacturer P/N
1	C1	4.7uF	Ceramic Cap, 35V, X7R	1210	Murata	GRM32ER71H475KA88L
					Holystone	C1210B475M035T
1	C2	NC	Ceramic Cap, 35V, X7R	1206	TDK	C3216X7R1H105K
1	C3	0.1uF	Ceramic Cap, 16V, X7R	603	TDK	C1608X7R1C104K
1	C4	2.2uF	Ceramic Cap, 16V, X7R	1210	Murata	GRM32MR71C225MC01L
1	C5	2.2uF	Ceramic Cap, 16V, ±10%, X7R	805	TDK	C2012X7R1C225K
2	R1, R2	1K	Film Res, 5%	603	Panasonic	ERJ-3GEYJ102V
1	R3	499k	Film Res, 1%	603	Panasonic	ERJ-3EKF4993V
1	R4	100k	Film Res, 1%	603	Panasonic	ERJ-3EKF1003V
1	R5	2.21K	Film Res, 1%	603	Panasonic	ERJ-3EKF2211V
1	R6	3.6K	Film Res, 1%	603	YAGEO	9C06031A3601FKHFT
1	R7	8.66K	Film Res, 1%	603	Panasonic	ERJ-3EKF8661V
1	R8	0Ω	Film Res, 5%	603	YAGEO	9C06031A0000FKHFT
1	JP1, JP2, JP3		3x2-Pin Connector Header, 0.100"		Molex	10-89-1601
1	LED1		Led Green, Surface Mount	805	Panasonic	LNJ306G5URA
1	LED2		Led Red, Surface Mount	805	Panasonic	LNJ206R5RRX
1	U1		Linear Charger	QFN10	MPS	MP2605DQ

PRINTED CIRCUIT BOARD LAYOUT

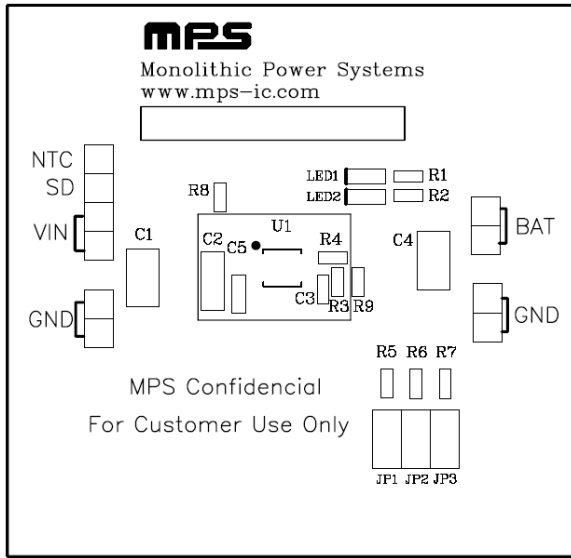

Figure 1—Top Silk Layer

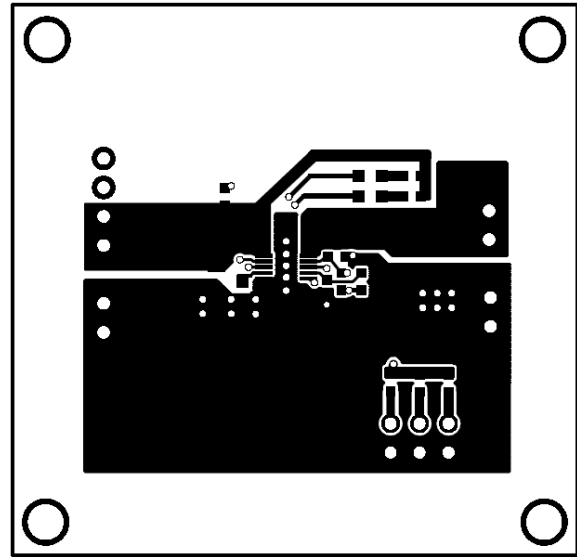

Figure 2—Top Layer

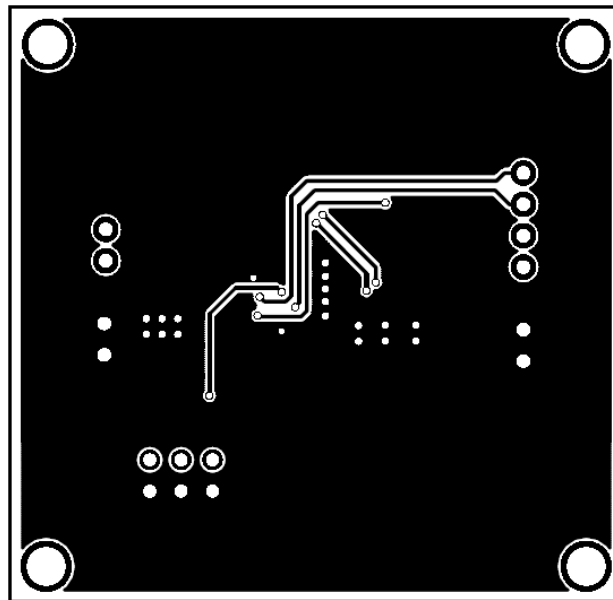

Figure 3—Bottom Layer

QUICK START GUIDE

The output voltage on this board is preset to 4.2V (for a single cell battery). The board layout accommodates most commonly used capacitors.

The LEDs are power indicators. When LED1 is on, the 5V input is present (LED1 is off when the input is disconnected). When LED2 is on, the battery is charging, and when the battery is full or there is no battery connected, LED 2 will turn off.

1. Set the charge current I_{CHG} using the jumpers JP1, JP2 and JP3 per the following table:

JP1	JP2	JP3	I_{CHG}
X		X	1000mA
X			800mA
	X	X	700mA
	X		500mA
		X	200mA

Where “X” indicates a connection.

2. Attach the positive and negative ends of the load to the VOUT and GND pins, respectively.
3. Attach the input voltage ($V_{IN}=5V$) and the input ground to the VIN and GND pins, respectively.
4. The timer cap, C5 on EVB is 2.2 μ F. This will set the oscillator frequency to be 5HZ. For different oscillator frequency setting, please follow the formula:

$$F_{osc} = 5Hz \times \frac{2.2\mu F}{C_5}$$

NOTICE: The information in this document is subject to change without notice. Please contact MPS for current specifications. Users should warrant and guarantee that third party Intellectual Property rights are not infringed upon when integrating MPS products into any application. MPS will not assume any legal responsibility for any said applications.