

DESCRIPTION

The MP6919 is a fast turn-off, intelligent rectifier for flyback converters that integrates a 100V/13mΩ MOSFET. It can replace a diode rectifier for higher efficiency and power density. The chip regulates the forward voltage drop of the internal power switch to 40mV and turns off before the drain-source voltage reverses.

The MP6919 can generate its own supply voltage without the need for auxiliary winding, which makes it suitable for charger applications with a low output voltage requirement or any other adaptor applications with high-side set-up. The internal ringing detection circuitry prevents the MP6919 from falsely turning on during discontinuous conduction mode (DCM) or quasi-resonant operations.

EV6919-S-00A is the evaluation board for MP6919.

FEATURES

- Integrated 100V/13mΩ MOSFET
- Wide Output Range down to 0V
- No Need for Auxiliary Winding for High-Side or Low-Side Rectification
- Ringing Detection Prevents False Turn-On during DCM Operations
- Compatible with Energy Star
- Supports DCM, CCM, and Quasi-Resonant Operations

APPLICATIONS

- Laptop Adapters
- QC and USB PD Charger
- High-Efficiency Flyback Converters

All MPS parts are lead-free, halogen free, and adhere to the RoHS directive. For MPS green status, please visit MPS website under Quality Assurance.

"MPS" and "The Future of Analog IC Technology" are Registered Trademarks of Monolithic Power Systems, Inc.

EV6919-S-00A EVALUATION BOARD



(L x W) 2.2cm x2.2cm

Board Number	MPS IC Number
EV6919-S-00A	MP6919GS

EVALUATION BOARD SCHEMATIC

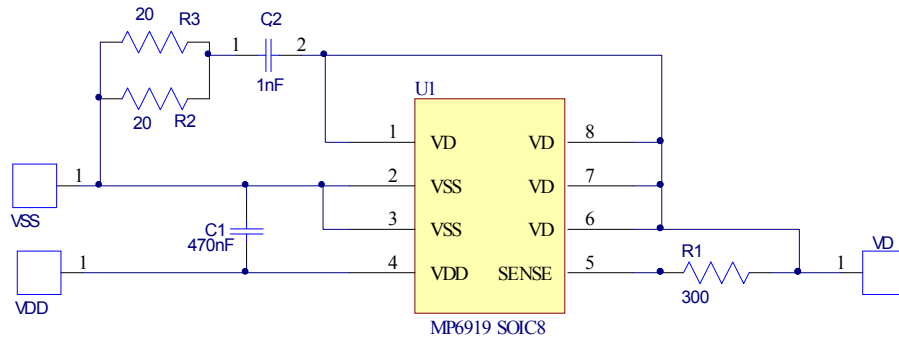

BILL OF MATERIALS

Qty	RefDes	Value	Description	Package	Manufacturer	Manufacturer P/N
1	C1	470nF	Ceramic Capacitor;50V;X7R	0805	Murata	GRM21BR71H474KA88
1	C2	1nF	Ceramic Capacitor;250V;X7R	0805	TDK	GRM21AR72E102KW01 D
1	R1	300	Film Resistor;1%	0603	Yageo	RC0603FR-07300RL
2	R2,R3	20	Film Resistor;1%	1206	Yageo	RC1206FR-0720RL
1	U4	MP6919GS	R7	SOIC-8	MPS	R7
3	VS,VD,VDD	Connector	1.0mm			

PRINTED CIRCUIT BOARD LAYOUT

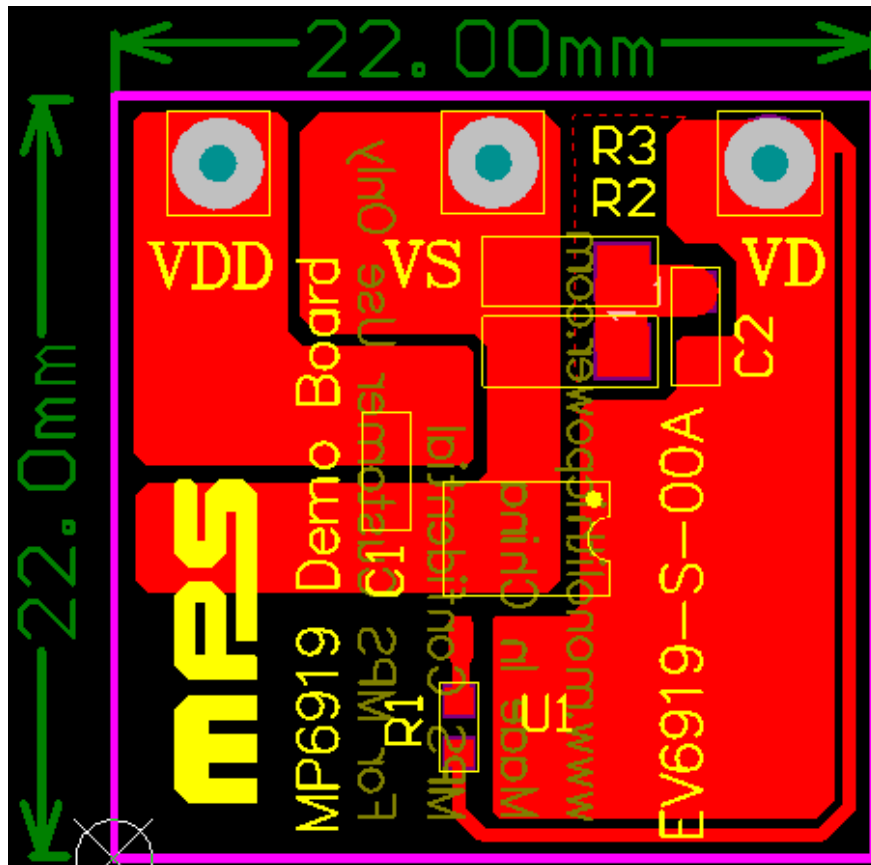

Figure 1: Top Layer

QUICK START GUIDE

1. Connect the VS and VD pin into the flyback circuit to replace the freewheel diode.
2. Turn the power supply on. The IC will start up and work as a freewheel diode automatically.

NOTICE: The information in this document is subject to change without notice. Users should warrant and guarantee that third party Intellectual Property rights are not infringed upon when integrating MPS products into any application. MPS will not assume any legal responsibility for any said applications.