

PART NO.	A99000-031	REV	ECO	DATE	APP
		C	104188	01-29-18	HV

MATERIALS

HOUSING:
ALUMINUM 6061, NICKEL PLATE
(500 MICROINCHES MINIMUM)
PER SAE-AMS-2404

INSULATOR:
LIQUID CRYSTAL POLYMER (LCP)
PER ASTM D5138

CONTACT/SOLDERCUP:
COPPER ALLOY PER MIL-DTL-
83513, GOLD PLATED PER ASTM
B488, (HARD GOLD) TYPE II
CODE C CLASS 1.27

INTERFACIAL SEAL:
SILICONE RUBBER PER A-A-
59588

HARDWARE:
AVAILABLE UPON REQUEST

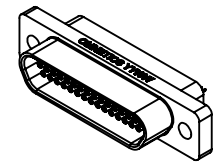
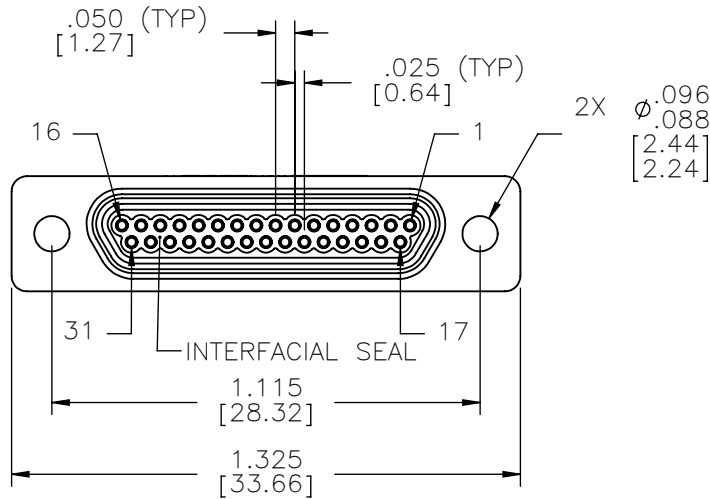
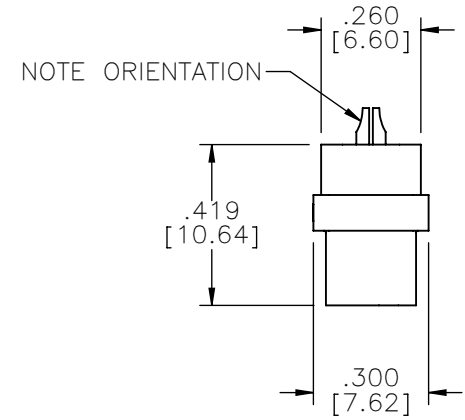
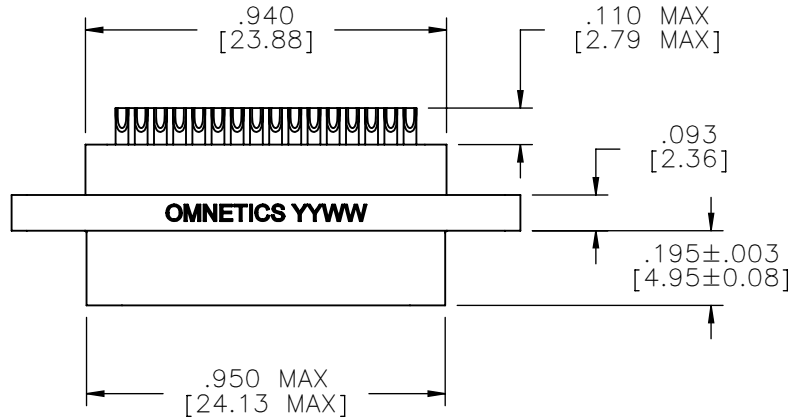

ACTUAL SIZE

RoHS

NOTE:

DIMENSIONS IN [] ARE IN MILLIMETERS UNLESS OTHERWISE NOTED AND ARE FOR REFERENCE ONLY

MGT'S SCHEM SLDW	THIRD ANGLE	THIS DRAWING CONTAINS CONFIDENTIAL AND PROPRIETARY INFORMATION WHICH IS THE PROPERTY OF OMNETICS CONNECTOR CORP. THIS DOCUMENT MAY NOT, IN WHOLE OR IN PART, BE DUPLICATED, OR DISCLOSED FOR ANY PURPOSE, WITHOUT WRITTEN PERMISSION FROM OMNETICS CONNECTOR CORP.	
	-TOLERANCES-	DFTM. NJS	DATE 01-13-10
	UNLESS OTHERWISE NOTED	CHK'D.	DATE
	DIMENSIONS IN INCHES	APP'D.	DATE
2 PL DEC± .01	TITLE: (31) SOCKET FEMALE MICRO-D CONNECTOR		
3 PL DEC± .005			
4 PL DEC± .0005			
ANGLES ± 1°			

OMNETICS
CONNECTOR CORPORATION
7260 COMMERCE CIRCLE EAST
MINNEAPOLIS, MN 55432
WWW.OMNETICS.COM

CAGE CODE 61873	
DWG NO. A99000-031	
SHEET 1 OF 1	REV C
SCALE: 2:1	