



The Infinite Bandwidth Company™

# MIC5400

Dual, 8-Output, 14-Bit LED Video Display Driver

## Preliminary Information

### General Description

The MIC5400 consists of 2 banks of 8 LED driver outputs, each output capable of sinking up to 30mA. Each bank is intended to drive 8 LED pixels of the same color. Most applications will use the MIC5400 to drive pixel clusters of 4 LEDs [RRGB] Typically two red LEDs are used for every one green and blue to compensate for red LED brightness.

A single external resistor sets maximum drive current. Use of an external resistor allows different color LED banks to be biased to the same intensity. Brightness control is digitally programmed through the serial interface. Coarse Brightness Control is determined by two 4 Bit DACs, one for each driver bank, limiting the full-scale output to a fraction of the maximum value. Additionally, each output has Fine Brightness Control using 10-bit resolution PWM.

Groups of drivers can be cascaded in Daisy Chain fashion. Open circuit output faults are detected and can be read back from the internal Status register.

### Features

- 2 Banks of 8 Outputs
- Output Characteristics:
- Current Sink: 30mA
- Programmable Brightness Control
  - Coarse: 4-Bit Resolution DAC
  - Fine: 10-Bit Resolution PWM
- Resistor sets Maximum LED Current to compensate . variation in LEDs
- Current Limit On Each Output
- Full Protection:
  - Over Temperature Shutdown
  - Watchdog Disables Output Under Fault Condition
  - Power-on Reset [all LEDs Off]
  - Soft-Start on Power Up and Watchdog Recovery
  - Output Open Fault Detection with Status register readback
- Output Transitions Are Staggered To Minimize Supply Transients

### Applications

- Outdoor Video Screen
- Large LED Display

### Ordering Information

Part Number	Ambient Temp. Range	Package
MIC5400CWM	-25°C to +70°C	28 Pin Wide SOIC

### Typical Application

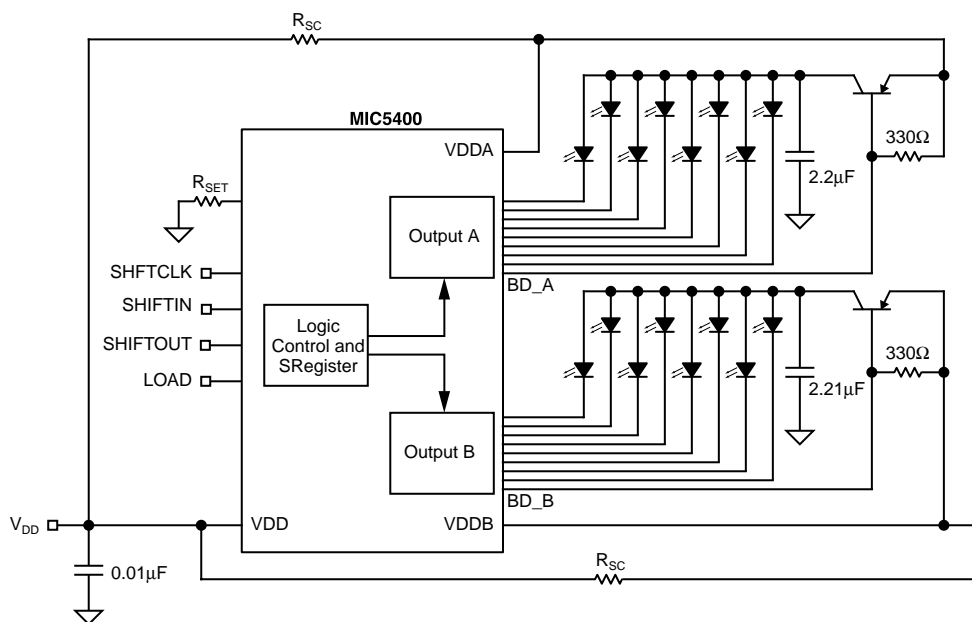

V<sub>DD</sub> decoupling: 10 nF [0.01 µF]

## Pin Configuration

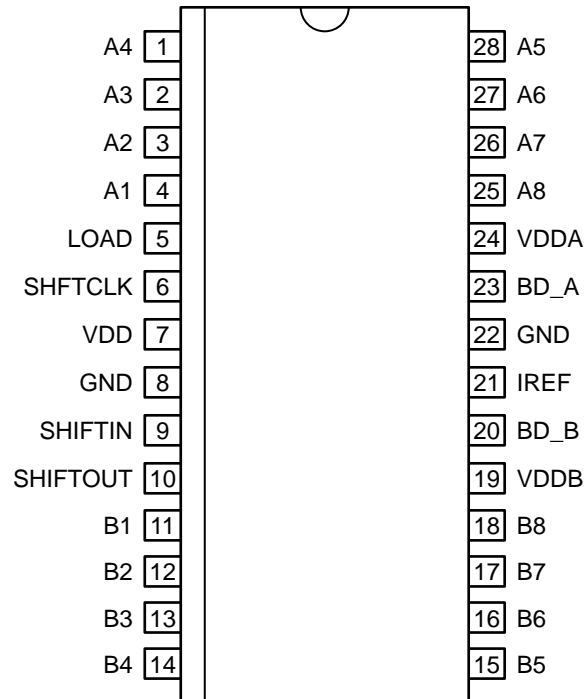

**28-Lead SOIC**

## Pin Description

Pin Number	Pin Name	Pin Function
Pin	Name	Function
1,2,3,4	A4,A3,A2,A1	Current Sink pins to be connected to LED cathodes
5	LOAD	If this pin is Low, the device acts as a shift register. When this pin is High, only the first falling edge of the clock transfers data from the Shift-Register to the Parallel Register. The next rising edge transfers data from the Status Register to the Shift Register
6	SHFTCLK	Shift-register Clock Input
7	VDD	Positive Supply Voltage
8,22	GND	Ground
9	SHIF TIN	Shift-register Data Input
10	SHIF TOUT	Shift-register Data Output
11,12,13,14	B1,B2,B3,B4	Current Sink pins to be connected to LED cathodes
15,16,17,18	B5,B6,B7,B8	Current Sink pins to be connected to LED cathodes
19	VDDB	Analog Power source pins which provide current sense points for Channel A and Channel B PNP emitter currents, independently.
20	BD_B	Base Drive Outputs for external PNP transistors. Feedback Loop compensation requires one external capacitor at each PNP transistor collector.
21	REF	Reference current output. Must be connected to an external resistor to set the maximum current for the current sink outputs.
23	BD_A	Base Drive Outputs for external PNP transistors. Feedback Loop compensation requires one external capacitor at each PNP transistor collector.
24	VDDA	Analog Power source pins which provide current sense points for Channel A and Channel B PNP emitter currents, independently.
25,26,27,28	A8,A7,A6,A5	Current Sink pins to be connected to LED cathodes

**Absolute Maximum Ratings (Note 1)**

Supply Voltage .....	7V
Input Voltage .....	-0.3V to $V_{CC} + 0.3V$
Base Drive Voltage .....	7V
Output Sink Current (per Output) .....	35mA
Lead Temperature (soldering, 5 sec) .....	260°C
$T_J(\text{max})$ .....	125°C
ESD Rating (Note 3) .....	[tbd]kV

**Operating Ratings (Note 2)**

Supply Voltage ( $V_{CC}$ ) .....	4.75V to 5.5V
Ambient Temperature Range .....	-25°C to +70°C
Thermal Resistance:	
( $\theta_{J-C}$ ) .....	28°C/Watt
( $\theta_{J-A}$ ) .....	100°C/Watt

**DC Electrical Characteristics**

$V_{DD} = 4.75V$  to  $5.5V$ ,  $T_A = 25^\circ C$ , **bold** values indicate  $-25^\circ C \leq T_A \leq +70^\circ C$ .  $R_{BIAS} = 500\Omega$ . Applies to all channels unless noted

Symbol	Parameter	Condition	Min	Typ	Max	Units
$I_{OUT}$	Output Sink Current		<b>26</b>		<b>35</b>	mA
$\Delta I_{OUT}$	Output Current Matching				<b>7</b>	%
$I_{OUT(OFF)}$	Output Off Leakage	$V_{OUT} = 5V$	<b>-1</b>		<b>1</b>	$\mu A$
$I_{DD}$	Supply current	$V_{DD} = 5.5V$	<b>0</b>		<b>2</b>	mA
$I_B$	PNP Base Drive Current	$V_{BD} = 4V$	<b>7</b>		<b>50</b>	mA
$V_{REF}$	Reference Output Voltage	$I_{REF} = -4mA$	<b>1.9</b>		<b>2.1</b>	V
$V_{IH}$	Logic 1 Input Threshold		<b>2.2</b>			V
$V_{IL}$	Logic 0 Input Threshold				<b>0.8</b>	V
$V_{OH}$	Logic 1 Output Level	$I_{LOAD} = 1mA$	<b>2.4</b>			V
$V_{OL}$	Logic 0 Output Level	$I_{LOAD} = 1mA$			<b>0.4</b>	V
$T_{SHUTDOWN}$	Thermal Shutdown Temperature			165		°C

**AC Electrical Characteristics**

$V_{DD} = 4.75V$  to  $5.5V$ ,  $T_A = 25^\circ C$ , **bold** values indicate  $-25^\circ C \leq T_A \leq +70^\circ C$ .  $R_{BIAS} = 500\Omega$ . Applies to all channels unless noted

Symbol	Parameter	Conditions	Min	Typ	Max	Units
$f_{SHIFT}$	Shift Frequency				<b>15</b>	MHz
$t_{SET-DATA}$	Set Up Time for Data In	Note 5	7			ns
$t_{HOLD-DATA}$	Hold Time for Data In	Note 5	13			ns
$t_{SET-LOAD}$	Set Up Time for Load	Note 5	20			ns
$t_{HOLD-LOAD}$	Hold Time for Load	Note 5	13			ns
$I_{OUT(tr)}$	Rise Time Iout	Note 4, 5			<b>125</b>	ns
$I_{OUT(tff)}$	Fall Time Iout	Note 4, 5			<b>50</b>	ns
$t_{D-SHIFT}$	Clock to Shift Out Delay	Rise and Fall, 50% Cload = 30 pF, Note 5			<b>23</b>	ns
$t_{r,f-OUT}$	Shift Out Rise and Fall Time	10% to 90%; $C_{LOAD} = 30pF$ , Note 5			<b>10</b>	ns
$t_{WD-TIMEOUT}$	Watch Dog Timeout Delay	No Shiftclock	<b>25</b>		<b>200</b>	$\mu s$
$t_{r,f[in]}$	Logic Input Rise and Fall Times				10	ns

**Note 1.** Exceeding the absolute maximum rating may damage the device.

**Note 2.** The device is not guaranteed to function outside its operating rating.

**Note 3.** Devices are ESD sensitive. Handling precautions recommended. Human body model, 1.5k in series with 100pF.

**Note 4.** Test circuit shown in Figure 1.

**Note 5.** Guaranteed by design; not production tested.

### Test Circuit

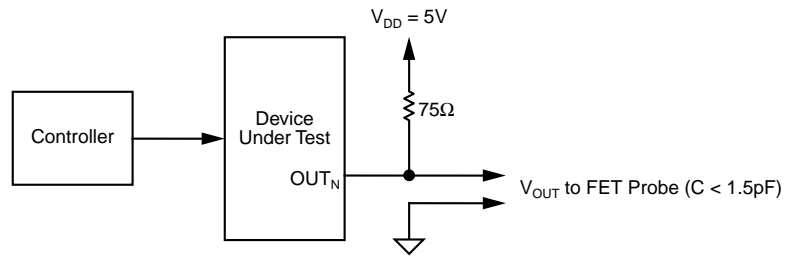

Figure 1. AC Output Test Circuit

### Timing Diagrams

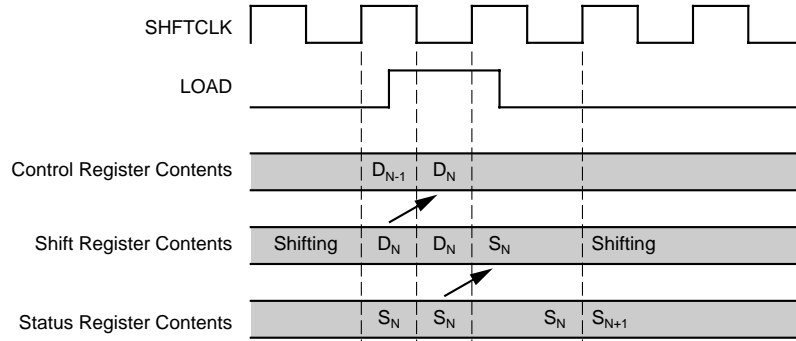
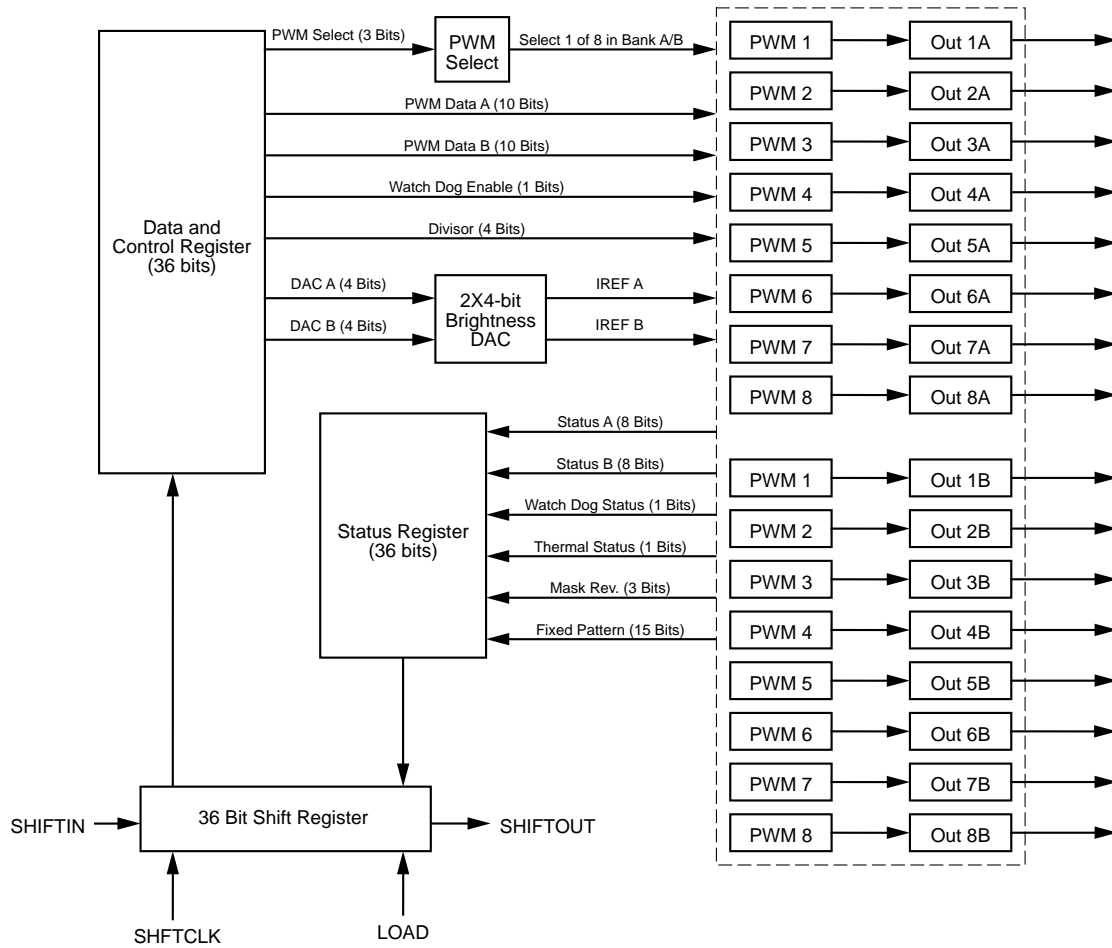

Figure 2. MIC5400 Timing Diagram

# Functional Diagram



**MIC5400 Functional Diagram**

Address	Data A	Data B	Watchdog	Divisor	DAC B	DAC B
3 Bits	10 bits	10 Bits	1 Bit	4 Bits	4 Bits	4 Bits
Q1 to Q3 [Q1 = LSB]	Q4 to Q13	Q14 to Q23	Q24	Q25 to Q28	Q29 to Q32	Q33 to Q36

Bit	Description
1	Address bit 1
2	Address Bit 2
3	Address Bit 3
4	Data A Bit 1
5	Data A Bit 2
6	Data A Bit 3
7	Data A Bit 4
8	Data A Bit 5
9	Data A Bit 6
10	Data A Bit 7
11	Data A Bit 8
12	Data A Bit 9
13	Data A Bit 10
14	Data B Bit 1
15	Data B Bit 2
16	Data B Bit 3
17	Data B Bit 4
18	Data B Bit 5
19	Data B Bit 6
20	Data B Bit 7
21	Data B Bit 8
22	Data B Bit 9
23	Data B Bit 10
24	Watchdog Bit [Disable = 1]
25	Divisor Bit 1
26	Divisor Bit 2
27	Divisor Bit 3
28	Divisor Bit 4
29	DAC A Bit 1
30	DAC A Bit 2
31	DAC A Bit 3
32	DAC A Bit 4
33	DAC B Bit 1
34	DAC B Bit 2
35	DAC B Bit 3
36	DAC B Bit 4

**Table 1. Shift Register Data Format**

Status A [1 = Open Circuit]	Status B [1 = Open Circuit]	Watchdog [1 = Timeout]	Thermal [1 = Overtemp]	Mask Revision	Alternating Bits
8 Bits	8 Bits	1 Bit	1 Bit	3 Bits	15 Fixed Bits
D1-D8	D9-D16	D17	D18	D19 to D21	D22 to D36

Bit	Description
1	Status A - Bit 1 (Output Open Circuit = 1)
2	Status A - Bit 2 (Output Open Circuit = 1)
3	Status A - Bit 3 (Output Open Circuit = 1)
4	Status A - Bit 4 (Output Open Circuit = 1)
5	Status A - Bit 5 (Output Open Circuit = 1)
6	Status A - Bit 6 (Output Open Circuit = 1)
7	Status A - Bit 7 (Output Open Circuit = 1)
8	Status A - Bit 8 (Output Open Circuit = 1)
9	Status B - Bit 1 (Output Open Circuit = 1)
10	Status B - Bit 2 (Output Open Circuit = 1)
11	Status B - Bit 3 (Output Open Circuit = 1)
12	Status B - Bit 4 (Output Open Circuit = 1)
13	Status B - Bit 5 (Output Open Circuit = 1)
14	Status B - Bit 6 (Output Open Circuit = 1)
15	Status B - Bit 7 (Output Open Circuit = 1)
16	Status B - Bit 8 (Output Open Circuit = 1)
17	Watchdog Status [0 = Normal, 1 = Time Out]
18	Thermal Status [0 = Normal, 1 = Overtemp]
19	Mask Revision Bit 1
20	Mask Revision Bit 2
21	Mask Revision Bit 3
22	0 [Fixed Pattern Filler Bits]
23	1
24	0
25	1
26	0
27	1
28	0
29	1
30	0
31	1
32	0
33	1
34	0
35	1
36	0

Table 2. Status Word Format

## Applications Information

### Output Current Drive

The MIC5400 includes several ways to program LED output current. These output current controls are superimposed and have an additive effect on LED output current as follows:

#### Global Full Scale Current Limit:

This function sets the Global Full Scale [GFS] current at each of the outputs.. The GFS value current is about 8.1 times ISET. ISET is the current through the single resistor, RBIAS, connected from VREF to Ground. VREF is regulated to 2V (nominal) so:

$$I_{SET} = \frac{V_{REF}}{R_{BIAS}} = \frac{(2V)}{R_{BIAS}} \text{ and } GFS = \frac{[8.1] \times [2V]}{R_{BIAS}}$$

$$\text{For } R_{BIAS} = 500\Omega, GFS = \approx 32.4\text{mA}$$

### Brightness Control

Brightness control is provided by two, 4-bit DACs, one DAC for each of the two output banks of 8-outputs. The output current is varied between 0\*GFS and (15/16)\*GFS in 15 equal steps based on the 4 Bit DAC code from the shift register Data Word; Bits Q29-Q32 control Output Bank A and Bits QA33-36 control Output Bank B. (See Table 1: Data Word Format).

### Output Intensity

Each LED Output intensity is further controlled by a Pulse Width Modulator providing 10-bit Resolution intensity variation. One LED Output per bank can be set up for each Data Word. A 3-bit address selects 1 of the 8 PWMs for each of the two output banks. Programming bits Q1-Q3 determine the PWM address, bits Q4-Q13 control the PWMs driving Bank A, bits Q14-Q23 control the PWMs driving Bank B. The PWM is created by comparing the Count of a 10 Bit Counter with the 10 Bit Programming Word. If the Count Output is greater than the Programming Word, the Output is "OFF".

The PWM frequency is also programmable, in ratio to the frequency of the shift register clock. The ratio value is set by the Divisor, loaded into bits Q25-Q28 of the Data Word. [See Table 3.]

### Watchdog and Thermal Shutdown

The MIC5400 incorporates both a watchdog and thermal shutdown.

The thermal shutdown activates when the die temperature exceeds typically 165°C. The shutdown function is internal to the device, there is no flag or output.

The watchdog generates a fault condition if Shift Clock is not present for more than 25µs. The watchdog is enabled by Data Word Bit Q24. As a result of the 25µs minimum Watchdog Timeout Delay, the lower limit of clock frequency is 40 kHz.

Watchdog Status is read back from Status Word Bit Q17. Thermal Status is read from Status Word Bit Q18.

### External PNP Transistors

The external PNP's have a dual role. As part of a voltage regulator loop they aid in limiting package power dissipation. Sensing current in the PNP emitters also allows setting an overall limit to the current available to one bank of 8 LEDs.

Power dissipation: The regulator loop controls the voltage at the LED Drive Output to limit power dissipation. The outputs are typically controlled to 1.1V. A 2.2 µF capacitor is required at the collector of each PNP for frequency compensation.

### PNP Current Limit

The current limit of the external PNP can be set by connecting a sense resistor R<sub>CS</sub> from VDD to VDDA and VDDDB respectively. The current limit is:

$$I_{LIM} = \frac{48\text{mV}}{R_{SC}}$$

If current limit is not used, short VDDA and VDDDB to VDD.

### Daisy Chains

Parts may be cascaded in groups of arbitrary size. The SHIFTOUT pin of one part is connected to the SHIFTIN pin of the following part. Data bit 36 is the first bit data to be shifted in. Status bit 36 is the first status bit to be shifted out. (See Table 1 and Table 2)

When loading the 36 Bit Data Words, the user must keep track of the number of SHIFTCLOCK cycles to determine when data is aligned for transfer to the Control and PWM registers. For example, if one daisy chains 10 parts, 360 SHIFTCLOCK cycles are required to clock in all the Data Words.

### LOAD and the Data/Control and Status Registers:

When LOAD is low, the MIC5400 acts as a 36 Bit shift register. When LOAD goes High, the part no longer shifts data. Data is transferred from the Shift Register to the parallel Control Registers on the first falling edge of SHIFTCLK after LOAD goes high. While LOAD remains High, the next rising edge of SHIFTCLOCK transfers data from the Status Registers to the Shift Register. The first Status Bit to appear on SHIFTOUT is Status A, bit 1. See Table 2 for description and Figure 2 for timing.

Status A or Status B = 1 if the output is Open Circuit, i.e. Open LED.

After LOAD returns Low, normal Shift Register operation resumes and Status Data is shifted out as new Data Words are shifted in on the rising edge of SHIFTCLK.

Divisor Code	0	1	2	3	4	5	6	7	8	9	A	B	C	D	E	F
Divide by R	1	2	3	4	5	6	7	8	9	10	11	12	13	14	15	16

Table 3. PWM clock Ratio to Shift Clock [PWM Clock Freq. = (Shift Clock Freq)/R]



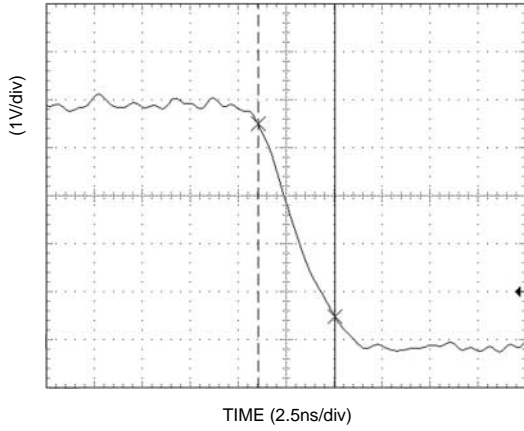

**Output Current Sink Rise Time**

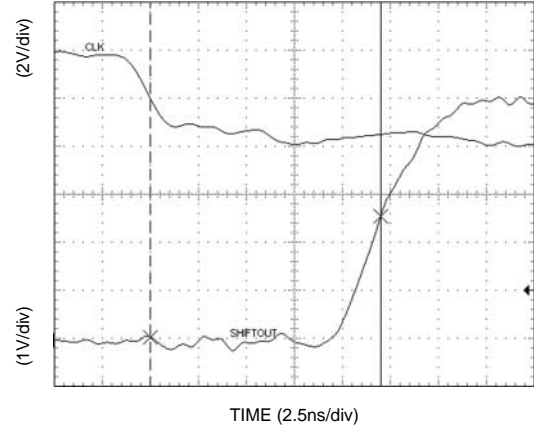

**Clock to Shiftout Delay Time**

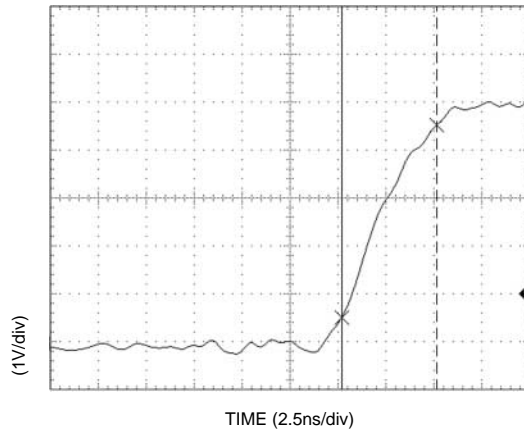

**Output Current Sink Fall Time**

Package Information

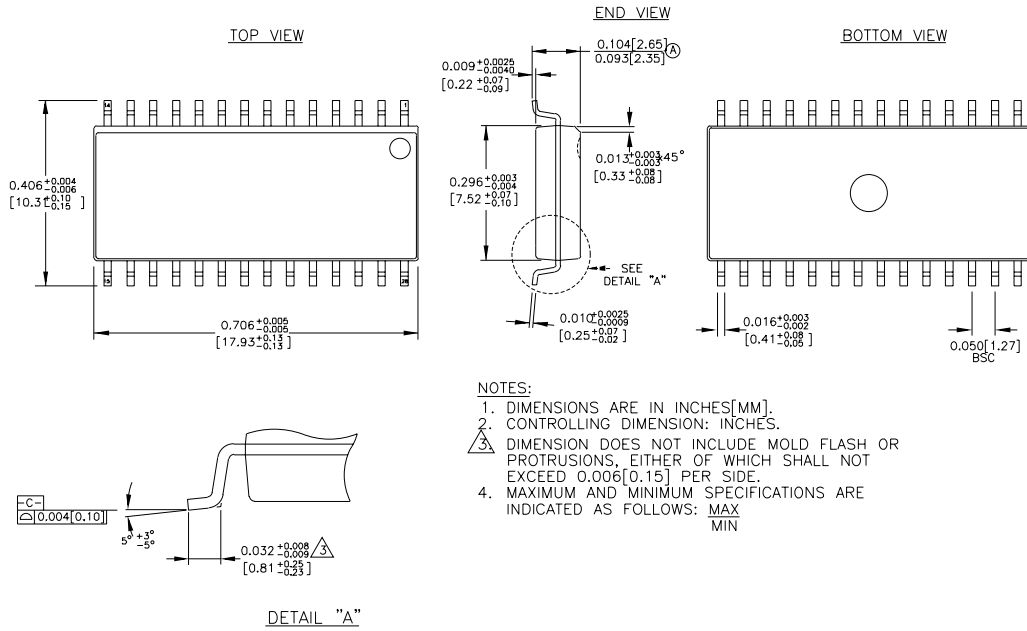

Rev. 02

28-Pin Wide SOIC

MICREL INC. 1849 FORTUNE DRIVE SAN JOSE, CA 95131 USA

TEL + 1 (408) 944-0800 FAX + 1 (408) 944-0970 WEB <http://www.micrel.com>

This information is believed to be accurate and reliable, however no responsibility is assumed by Micrel for its use nor for any infringement of patents or other rights of third parties resulting from its use. No license is granted by implication or otherwise under any patent or patent right of Micrel Inc.

© 2001 Micrel Incorporated