

DESCRIPTION

The EV6903DS-00A is an evaluation board for the MP6903DS. It is configured to provide synchronous rectification solution for LLC topology.

MP6903DS features a synchronous gate output which enables high efficiency rectification by relating the schottky rectifier with a low Ron MOSFET.

ELECTRICAL SPECIFICATIONS

Parameter	Symbol	Value	Units
Supply Voltage	V _{DD}	8–24	V

FEATURES

- Works with both Standard and Logic Level FETS
- Compatible with Energy Star, 1W Standby Requirements
- V_{DD} Range From 8V to 24V
- Fast Turn-off Total Delay of 20ns
- Max 400kHz Switching Frequency
- <300µA Quiescent Current at Light Load Mode
- Supports CCM, CrCM and DCM Operation Mode
- Supports High-side and Low-side Rectification

APPLICATIONS

- Industrial Power Systems
- Distributed Power Systems
- Battery Powered Systems

"MPS" and "The Future of Analog IC Technology" are Registered Trademarks of Monolithic Power Systems, Inc.

EV6903DS-00A EVALUATION BOARD



(L x W x H) 1.14" x 1.14" x 0.6"
2.9cm x 2.9cm x 1.4cm

Board Number	MPS IC Number
EV6903DS-00A	MP6903DS

EVALUATION BOARD SCHEMATIC

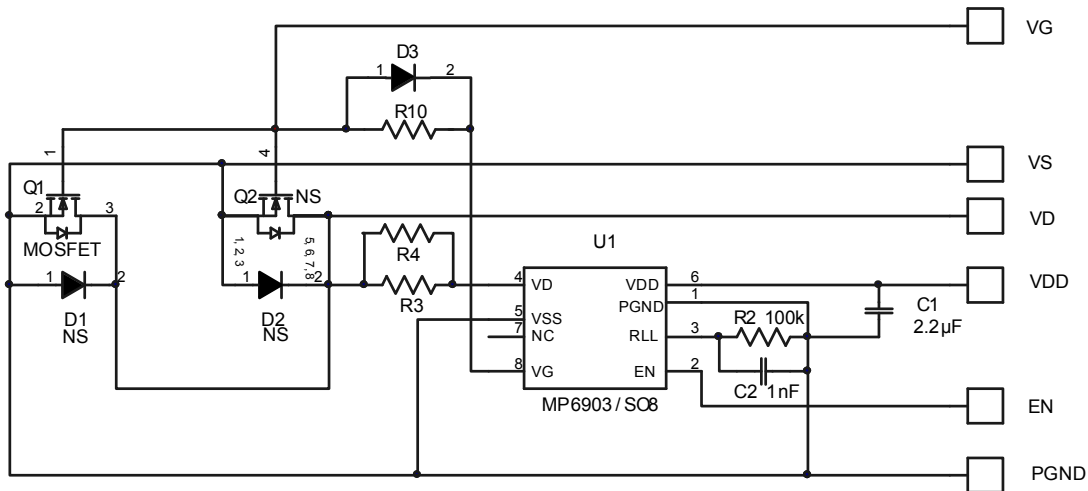

EV6903DS-00A BILL OF MATERIALS

Qty	RefDes	Value	Description	Package	Manufacturer	Manufacturer P/N
1	C1	2.2µF	Ceramic Cap., 25V, X7R	0805	muRata	GRM21BR71E225KA73L
1	C2	1nF	Ceramic Cap., 50V, X7R	0603	TDK	C1608X7R1H102K
1	R1	0	Film Res., 5%	0603	Yageo	RC0603JR-070RL
1	R2	100k	Film Res., 1%	0603	Yageo	RC0603FR-07100KL
1	R3	1k	Film Res., 1%	0603	Royalohm	0603F1001T5E
0	R4	NS				
1	Q1	MOSFET	N-CH 100V 8.8mΩ	TO220-AB	Vishay	SUP90N10-8M8P
			N-CH 100V 8mΩ	TO220	APEC	AP85T10GP
0	Q2	NS		PowerPAK-SO8		
0	D1	NS		SMC		
0	D2	NS		TO220		
1	D3	DIODES	75V/0.15A	SOD323	Diodes	IN4148WS-7-F
1	U1	MP6903DS	MP6903DS	SO-8	MPS	MP6903DS

PRINTED CIRCUIT BOARD LAYOUT

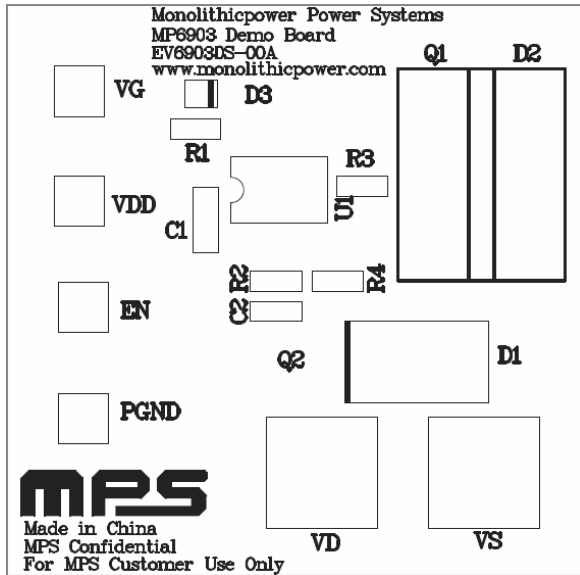

Figure 1—Top Silk Layer

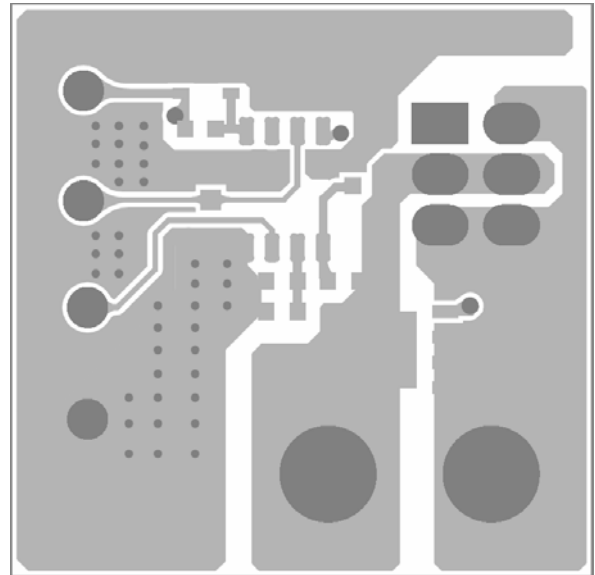

Figure 2—Top Layer

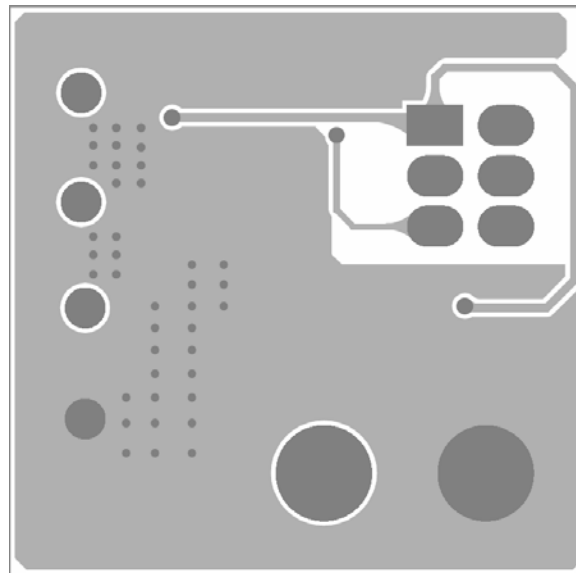

Figure 3—Bottom Layer

QUICK START GUIDE

1. Connect the positive and negative terminals of the output or the auxiliary winding to the VDD and VSS pins, respectively.
2. Connect the Drain and Source and Gate terminals of the synchronous power MOSFET to the VD and VS and VG pins, respectively (There is already a 100V power MOSFET Q1 connected on the board, if the customer do not want to use this MOS as synchronous MOSFET, you can remove this Q1 and use your own MOSFET instead).
3. Preset the input voltage of flyback converter to the normal input range, and then turn off the power supply.
4. Turn the power supply on. The IC will automatically startup and drive the synchronous MOSFET Q1 to work as an ideal diode.

NOTICE: The information in this document is subject to change without notice. Users should warrant and guarantee that third party Intellectual Property rights are not infringed upon when integrating MPS products into any application. MPS will not assume any legal responsibility for any said applications.