

## DESCRIPTION

The EV6601-U-00A is an evaluation board for the MP6601, a stepper motor driver with parallel inputs and current regulation.

The EV6601-U-00A operates from a supply voltage of up to 35V and can deliver motor current up to 2.5A. It can operate a bipolar stepper motor in full-, half- and quarter- step modes by setting corresponding inputs. The input control signals for the MP6601 are applied through the connectors or generated on board.

## ELECTRICAL SPECIFICATIONS

Parameter	Symbol	Value	Units
Input Voltage	V <sub>IN</sub>	4.5 - 35	V
Maximum Output Current	I <sub>OUT-L</sub>	2.5	A
Decay Mode	Automatic Decay		

## FEATURES

- Wide 4.5V to 35V Input Voltage Range
- Up to 2.5A Programmable Output Current
- Two Internal Full-bridge Drivers
- Internal Current Sensing and Regulator
- No Control Power Supply Required
- Operates from Full-step to 1/4-step
- Automatic Current Decay
- Over-current Protection
- Input OVP, UVLO Function
- Thermal Shutdown Protection
- Fault Indication Output

## APPLICATIONS

- Bipolar Stepper Motors
- Printers

All MPS parts are lead-free, halogen free, and adhere to the RoHS directive. For MPS green status, please visit MPS website under Quality Assurance.

"MPS" and "The Future of Analog IC Technology" are Registered Trademarks of Monolithic Power Systems, Inc.

## MP6601 EVALUATION BOARD

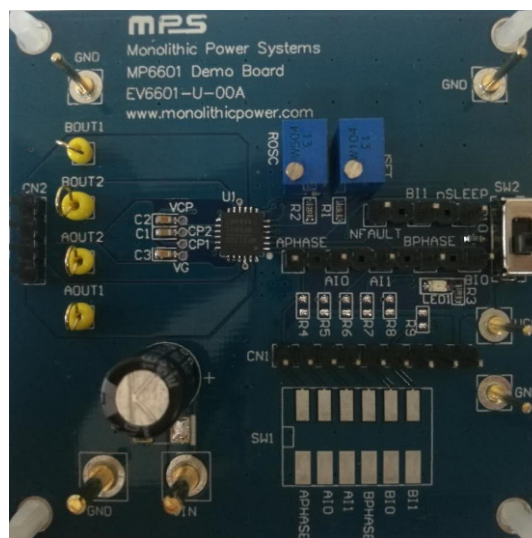

(L x W x H) 2.54" x 2.54" x 0.4"  
(6.35cm x 6.35cm x 1cm)

Board Number	MPS IC Number
EV6601-U-00A	MP6601GU

## MP6601 EVALUATION BOARD SCHEMATIC

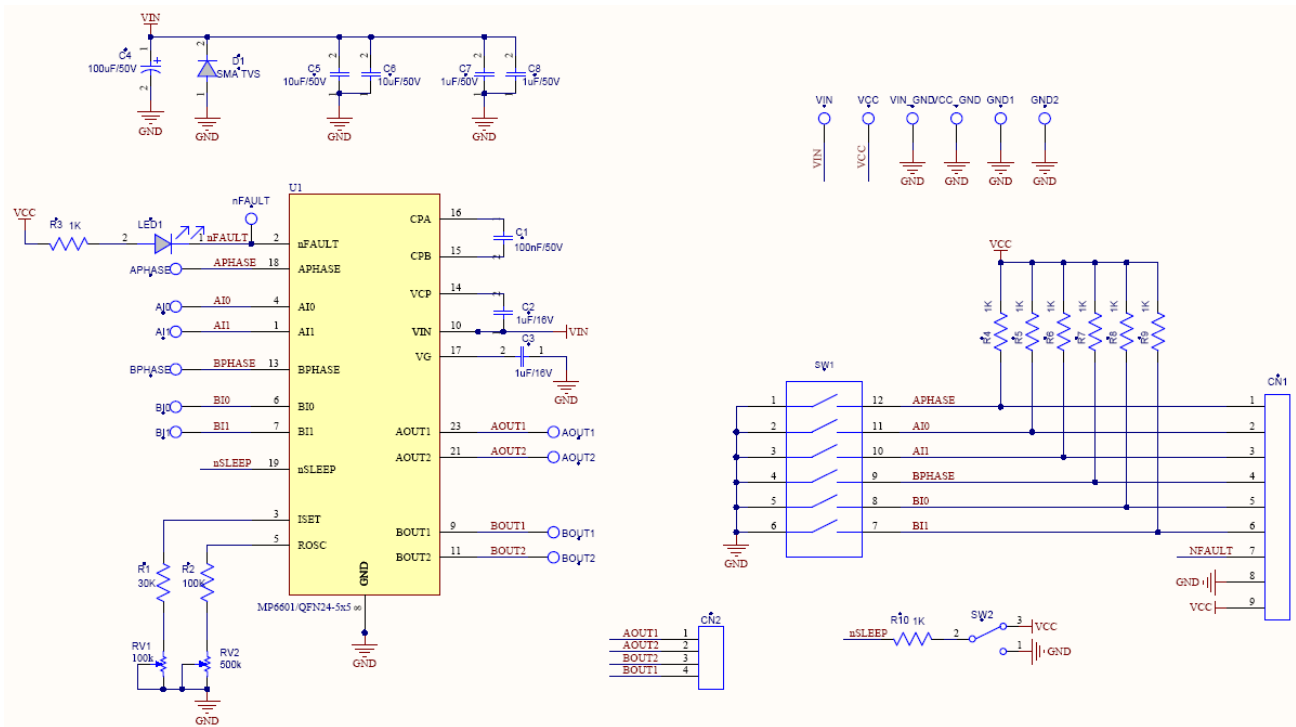

**MP6601 EVALUATION BOARD BILL OF MATERIALS**

Qty	RefDes	Value	Description	Package	Manufacturer	Manufacturer P/N
1	C1	100nF/50V	Ceramic Capacitor;50V;X7R	0603	muRata	GRM188R71H104KA93D
2	C2, C3	1µF/16V	Ceramic Capacitor;16V;X7R;	0603	muRata	GRM188R71C105KA12D
1	C4	100µF/50V	Electrolytic Capacitor;50V;Electrolytic	DIP	Rubycon	50YXF100MEFC
2	C5, C6	10µF/50V	Ceramic Capacitor;50V;X7R	1210	muRata	GRM32ER71H106KA12L
2	C7, C8	1µF/50V	Ceramic Capacitor;50V;X7R	0805	muRata	GRM21BR71H105KA12L
1	R1	30K	Film Resistor;1%	0603	Yageo	RC0603FR-0730KL
1	R2	100K	Film Resistor;1%	0603	Yageo	RC0603FR-07100KL
2	R3, R10	1K	Film Resistor;1%	0603	Yageo	RC0603FR-071KL
0	R4, R5, R6, R7, R8, R9	NS				
1	RV1	100k	Adjustable Resistor	DIP		3266W-1-104F
1	RV2	500k	Adjustable Resistor	DIP		3266W-1-504LF
1	LED1		LED;红光;	0805	佰鸿	BL-HUE35A-AV-TRB
0	SW1	NS	6-Bits Dial Switch	SMD	Würth	418121270806
1	SW2		Button			SS-12D01EG4
1	CN1		9PIN. 2.54MM Connector			
1	CN2		4PIN. 2.54MM Connector			
0	D1	NS				
8	nSLEEP, nFAULT, APHASE, AI0, AI1, BPHASE, BI0, BI1		Test Point			
2	VIN, VIN_GND		2.0 公针			
8	VCC, VCC_GND, AOUT1, AOUT2, BOUT1, BOUT2, GND1, GND2		1.0 公针			
1	U1		Stepper Motor Driver	QFN24 (5mmx5mm)	MPS	MP6601GU

EV6601-U-00A PRINTED CIRCUIT BOARD LAYOUT

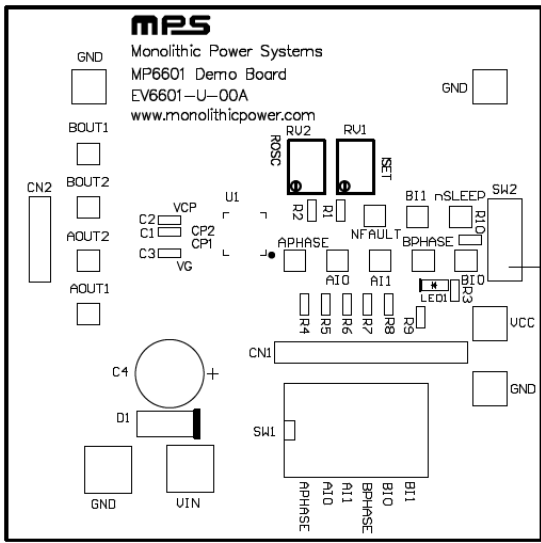

Figure 1—Top Silk Layer

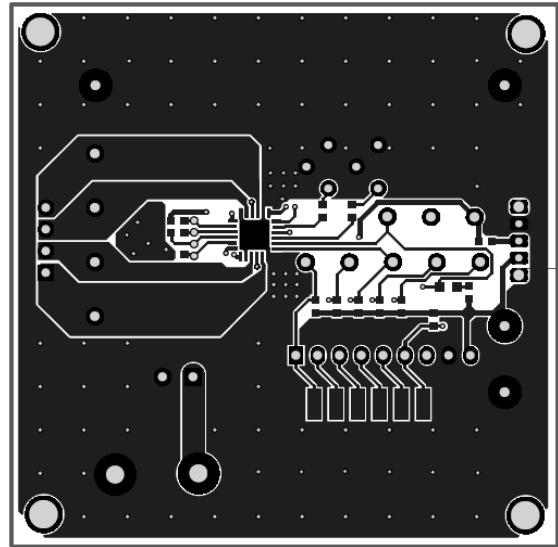

Figure 2—Top Layer

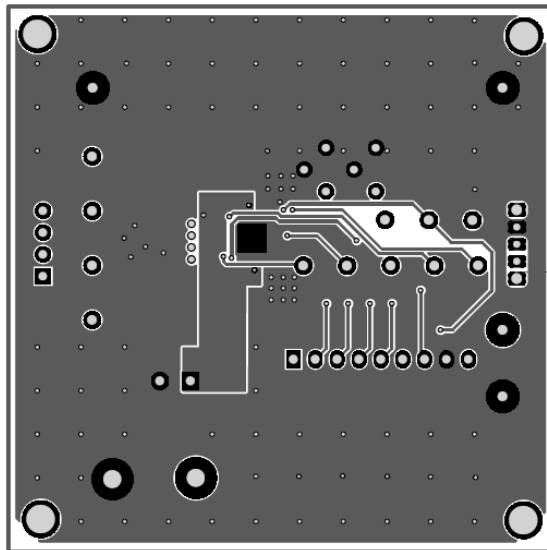

Figure 3—Bottom Layer

## QUICK START GUIDE

1. Attach the input voltage ( $4.5V \leq V_{IN} \leq 35V$ ) and input ground to the VIN and GND connectors respectively.
2. Attach the Vcc voltage (3.3V or 5V) and input ground to the Vcc and GND connectors respectively.
3. Switch the SW2 to the position 3 (downwards) to enable the part.
4. Input control and logic signals can be set either through the CN1 connector by external MCU inputs or through the SW1 by manual action. Manual action requires R4-R9 pull-up resistors.

The MP6601 contains two full H-bridges that operate independently. Each H-bridge has an input signal that controls the current flow direction in the H-bridge, as described in the table below:

xPHASE	xOUT1	xOUT2
0	L	H
1	H	L

In addition, each H-bridge has two input pins that are used to scale the current regulation point in the bridge. These pins function as follows:

xI1	xI0	Current
0	0	100%
0	1	71%
1	0	38%
1	1	0% (High impedance)

5. Adjust RV1 to program the full scale (100%) regulation current, it can be calculated with equation:  $I_{Max} = 71k\Omega / R_{SET}$
6. Adjust RV2 to program the constant off-time, it is approximated by:  $T_{off} (ns) = 190 \times R_t (k\Omega)$

**NOTICE:** The information in this document is subject to change without notice. Users should warrant and guarantee that third party Intellectual Property rights are not infringed upon when integrating MPS products into any application. MPS will not assume any legal responsibility for any said applications.