

5 V/3.3 V 5 A PoE PD with Buck Converter Evaluation Board User Guide

Introduction

Microchip’s EV59C37A evaluation board (see [Figure 2](#)) provides designers with the environment needed for evaluating the performance and implementation of non-isolated PD applications based on the PD70200 device.

The board uses a single PD device, PD70200, to support the detection, classification, and powering phases on the 2/4 pairs of the Cat 5 cable, and implements DC-DC converter with a synchronous buck regulator MIC28514. PD70200 supports a standard IEEE® 802.3af and IEEE 802.3at Type 2 interface. This document provides all the necessary steps and connection instructions required to install and operate this board. The EV59C37A evaluation board supports a 5 A load at 5 V and 3.3 V user-selectable outputs. The following figure shows the EV59C37A block diagram.

Figure 1. EV59C37A Block Diagram

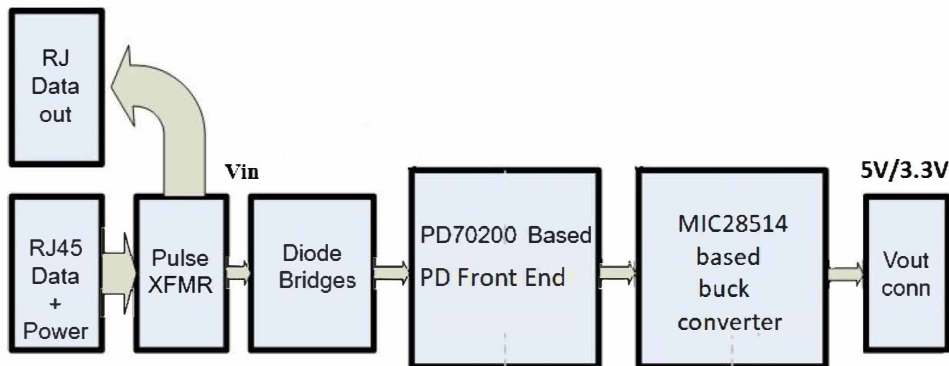
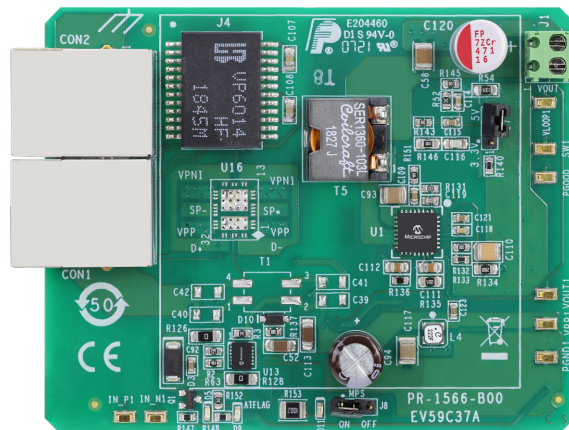


Figure 2. EV59C37A Evaluation Board—General View



Microchip’s PD70200 device is part of a family of devices that are targeted for realizing the IEEE 802.3at standard PD interface. The following table lists the PD interface family of devices.

Table 1. PoE PD Devices

P/N	Type	Package	IEEE 802.3af Support	IEEE 802.3at Support	HDBaseT Support	UPoE Support
PD70100	Front end	3 mm x 4 mm 12L DFN	x	—	—	—
PD70101	Front end + PWM	5 mm x 5 mm 32L QFN	x	—	—	—
PD70200	Front end	3 mm x 4 mm 12L DFN	x	x	—	—
PD70201	Front end + PWM	5 mm x 5 mm 32L QFN	x	x	—	—
PD70210	Front end	4 mm x 5 mm 16L DFN	x	x	x	x
PD70210A	Front end	4 mm x 5 mm 16L DFN	x	x	x	x
PD70210AL	Front end	5 mm x 7 mm 38L QFN	x	x	x	x
PD70211	Front end + PWM	6 mm x 6 mm 36L QFN	x	x	x	x
PD70224	Ideal Diode Bridge	6 mm x 8 mm 40L QFN	x	x	x	x

Reference Documents

- *PD70100/PD70200 Datasheet Power over Ethernet 802.3af/at PD Controller.*
- *AN3551 PD70101 and PD70201 PD Device Layout Guidelines.*
- *AN3471 Designing a Type 1/2 802.3 or HDBaseT Type 3 Powered Device Using PD702x1 and PD701x1 ICs.*
- *MIC28514 Datasheet 20005693E.*

Table of Contents

Introduction.....	1
1. Reference Documents.....	2
1. Overview.....	4
1.1. Ordering Information.....	4
1.2. Evaluation Board Features.....	4
1.3. Physical Characteristics.....	4
2. Physical Description.....	5
2.1. Package Contents.....	5
2.2. Connectors.....	5
2.3. Indications.....	7
3. Electrical Characteristics.....	8
4. Installation.....	9
4.1. Preliminary Considerations and Safety Precautions.....	9
4.2. Initial Configuration.....	9
5. Board Test Waveforms.....	10
6. Efficiency.....	13
6.1. Efficiency for 48 V Input at Input Connector.....	13
7. Schematic.....	14
8. Bill of Materials.....	16
9. Board Layout.....	19
10. Revision History.....	21
The Microchip Website.....	22
Product Change Notification Service.....	22
Customer Support.....	22
Microchip Devices Code Protection Feature.....	22
Legal Notice.....	23
Trademarks.....	23
Quality Management System.....	24
Worldwide Sales and Service.....	25

1. Overview

The following sections provide an overview of the EV59C37A evaluation board.

1.1 Ordering Information

Microchip supplies the following list of evaluation boards.

Table 1-1. Microchip Evaluation Boards

Ordering Number	Description
EV59C37A	IEEE 802.3at Type 2 PD, based on PD70200 and MIC28514 devices with non-isolated buck converter providing 5 V and 3.3 V at 5 A output.

1.2 Evaluation Board Features

The following features are supported in the EV59C37A evaluation board.

- Support for data and spare current by a single PD70200 device
- Two RJ45 connectors (Data and Power In, Data Out)
- Output voltage connector
- On-Board Power Good LED indicator
- On-Board AT detected LED indicator
- On-Board MPS LED indicator
- Pulse transformer for routing the data to PD application to enable full PD evaluation
- Evaluation board working temperature: $-30\text{ }^{\circ}\text{C}$ to $70\text{ }^{\circ}\text{C}$ (10% per $10\text{ }^{\circ}\text{C}$ load current derating above $50\text{ }^{\circ}\text{C}$)
- RoHS compliant

1.3 Physical Characteristics

The following table lists the physical characteristics of the evaluation board.

Table 1-2. Physical Characteristics

Parameter	Value (mm)
Mechanical dimensions	81 x 65 x 8 (L x W x H)

2. Physical Description

The following sections provide the physical description of the EV59C37A evaluation board.

2.1 Package Contents

Package content for standard shipments: EV59C37A Evaluation Board.

Note:

If it is damaged, contact your local Microchip CEM or ESE.

2.2 Connectors

The following sections provide information about the unit's connectors.

2.2.1 Connectors Table

The following table lists the evaluation board's connectors.

Table 2-1. Connectors List

#	Connector	Name	Description
1	CON1	RJ45 connector	RJ45 port for Data and Power Input for PSE connection
2	CON2	RJ45 connectors	RJ45 port for Data Out for PD data connection
3	J1	Converter output	Terminal blocks for connecting a load to the output
4	J7	Voltage select	Header for selecting output voltage with jumper (5 V or 3.3 V)
5	J8	MPS	Header for connecting and disconnecting MPS with jumper

2.2.2 Connectors Detailed Explanation

RJ45 Connectors

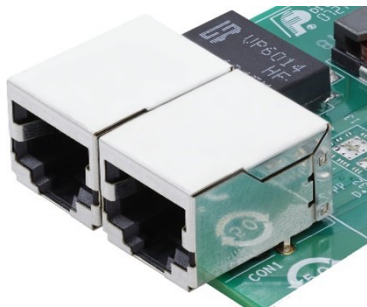
The following table lists the pin descriptions of the connectors listed in [Table 2-1](#).

Table 2-2. RJ45 Connectors

Connector	Pin Number	Signal Name	Description
CON2	1, 2, 3, 4, 5, 6, 7, and 8	Data Out	Data output to PD
CON1	1, 2, 3, 4, 5, 6, 7, and 8	Data and Power In	Data and power input to a powered device

The following figure shows the two dedicated RJ45 connectors.

Figure 2-1. Front RJ45



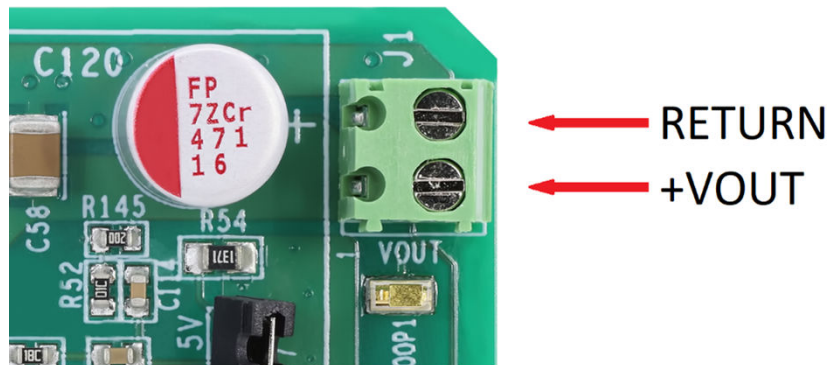
V_{out} Connectors

J1 is the DC-DC output connection used for connecting to an external load.

Pin Number	Signal Name	Description
J1 (Left)—Pin 1	V _{out}	Positive DC output voltage
J1 (Right)—Pin 2	V _{out_RTN}	Return of DC output voltage

The following figure shows the details of the V_{out} connectors.

Figure 2-2. V_{out} Connectors



2.3 Indications

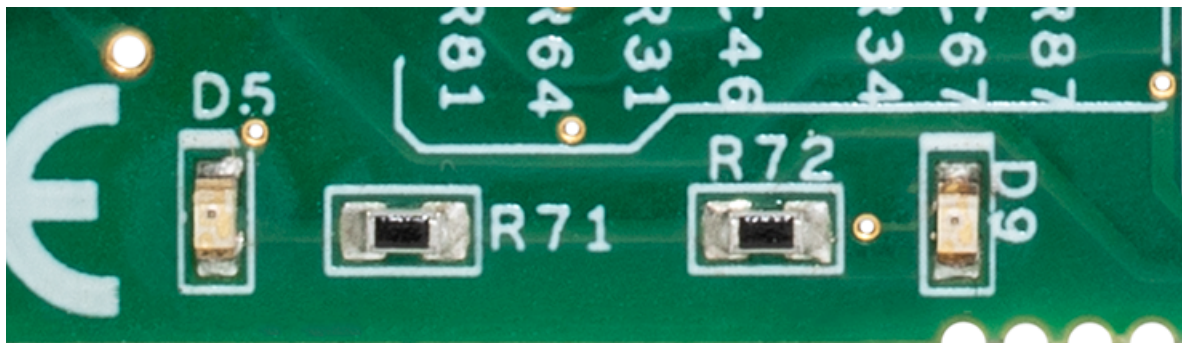
The following section provides general information about unit indications.

LED Indication

The following figure shows the LEDs on the evaluation board.

- D5 is the Power_GOOD indication LED. The MIC28514 device output signal indicates if the output voltage is within 90% of its setting.
- D9 is the AT flag indication LED. The PD70200 device output signal indicates that the device has detected two or more classification "fingers". Therefore, the PSE side is AT level capable. This signal is an indication to the PD environment that AT power level is supported.
- D11 is an MPS indicator. It provides an indication of optional on-board pre-load for keeping PSE connected at no output load.

Figure 2-3. LED Indications



3. Electrical Characteristics

The following table lists the EV59C37A evaluation board's electrical characteristics.

Table 3-1. Electrical Characteristics

Parameter	Min	Max	Unit
Main DC supply—CON1	42	57	V
Maximum available current	5	—	A
Port isolation to Earth Ground	—	1.5	kVrms

Note: Above 50 °C ambient temperature, reduce the load current by 10% per 10 °C.

4. Installation

The following sections describe the installation process of the EV59C37A evaluation board.

4.1 Preliminary Considerations and Safety Precautions

Verify if board's power supply is turned OFF before connecting all the peripheral devices are connected.

Note: In maximum power at the output, some of the devices might reach high temperatures (still less than 70 °C). Pay attention while testing these devices.

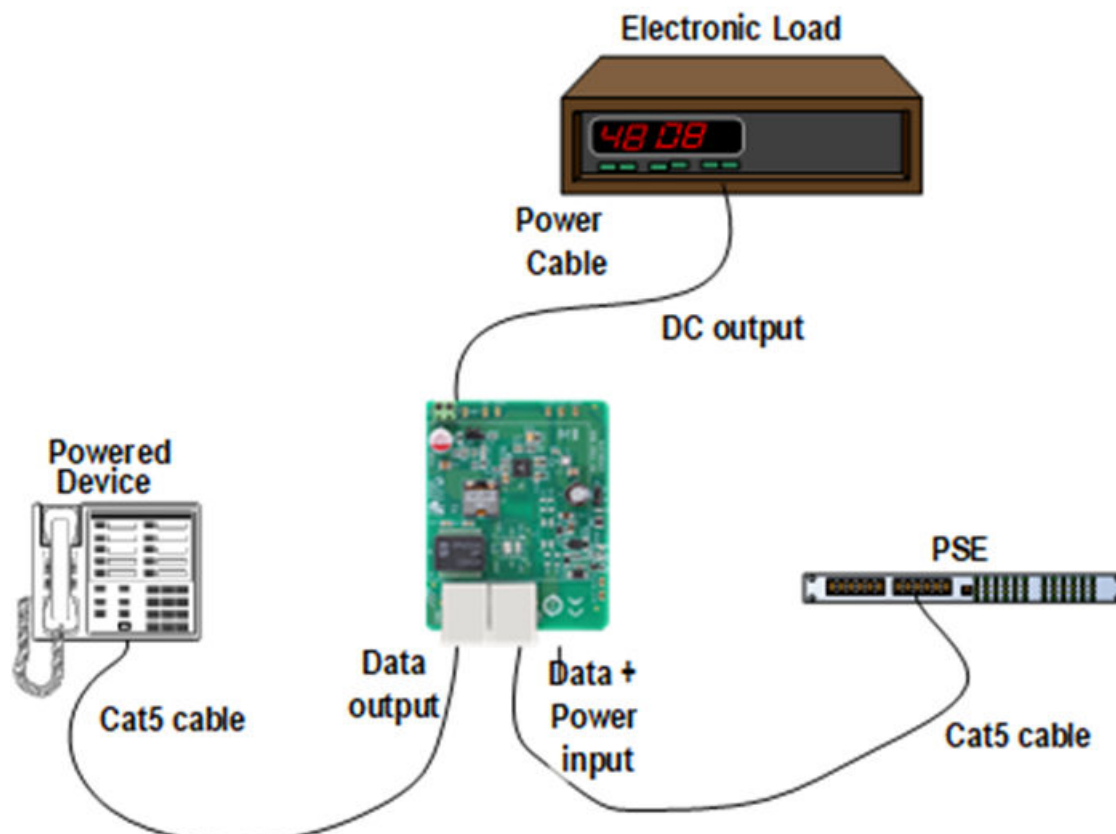
4.2 Initial Configuration

Prior to starting any operation, verify that the evaluation board is setup, as shown in the following figure.

Perform the following steps to verify the board set up.

1. Set the J7 jumper to select desired output (5 V or 3.3 V). Default factory output is 5 V.
2. Connect load to the main board (J1).
3. If external load is connected, move the J8 jumper to OFF position to disable MPS for higher efficiency.
4. Connect an Ethernet Cat 5 cable from PSE to the evaluation board (CON1).
5. When testing the Ethernet data (optional), connect another Ethernet Cat 5 cable from the evaluation board (CON2) to the PD Ethernet host.

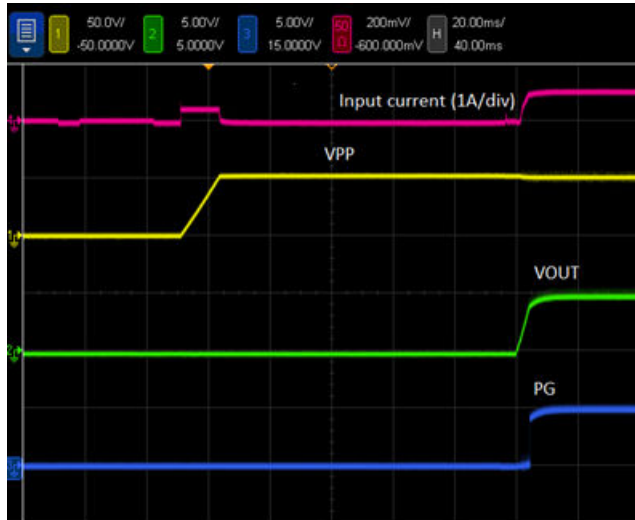
Figure 4-1. Test Setup



5. Board Test Waveforms

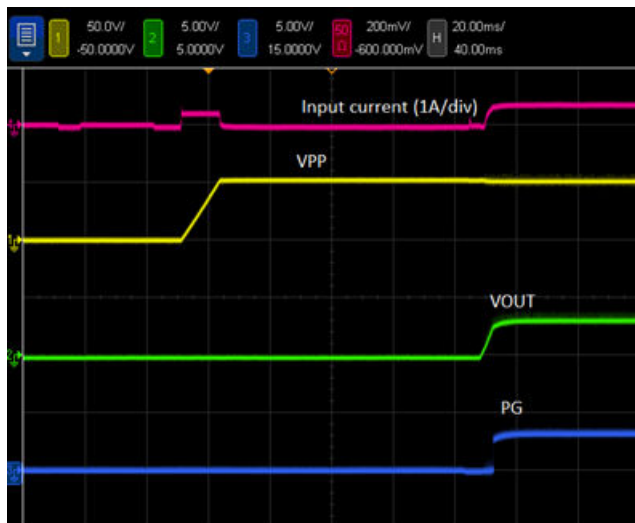
The following figures show the signals on the EV59C37 board. Waveforms were taken in Microchip’s lab on a single board and represent typical performance. There might be variations from board to board, based on test setup and devices variances.

Figure 5-1. 5 V Startup to 5 A Load



1—output of PD controller (VPP), 2—output voltage, 3—power good signal, and 4—input current in PoE cable

Figure 5-2. 3.3 V Startup to 5 A Load

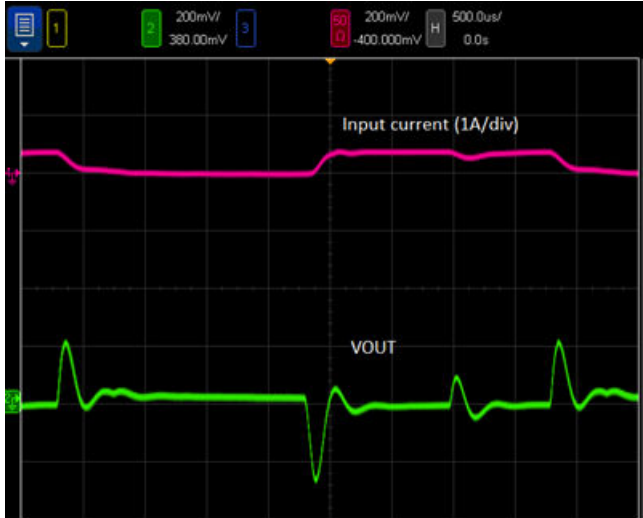


1—output of PD controller (VPP), 2—output voltage, 3—power good signal, and 4—input current in PoE cable

Figure 5-3. 5 V Output Voltage Transient Response from No Load to 5 A at 48 Vin.

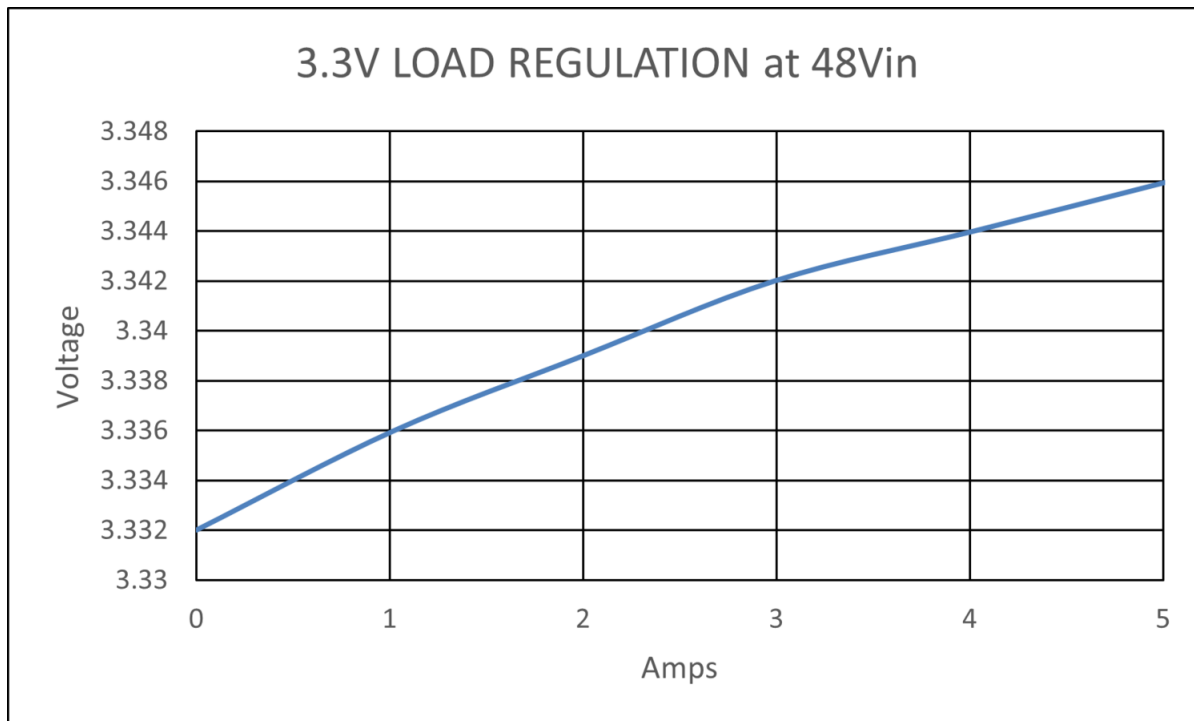
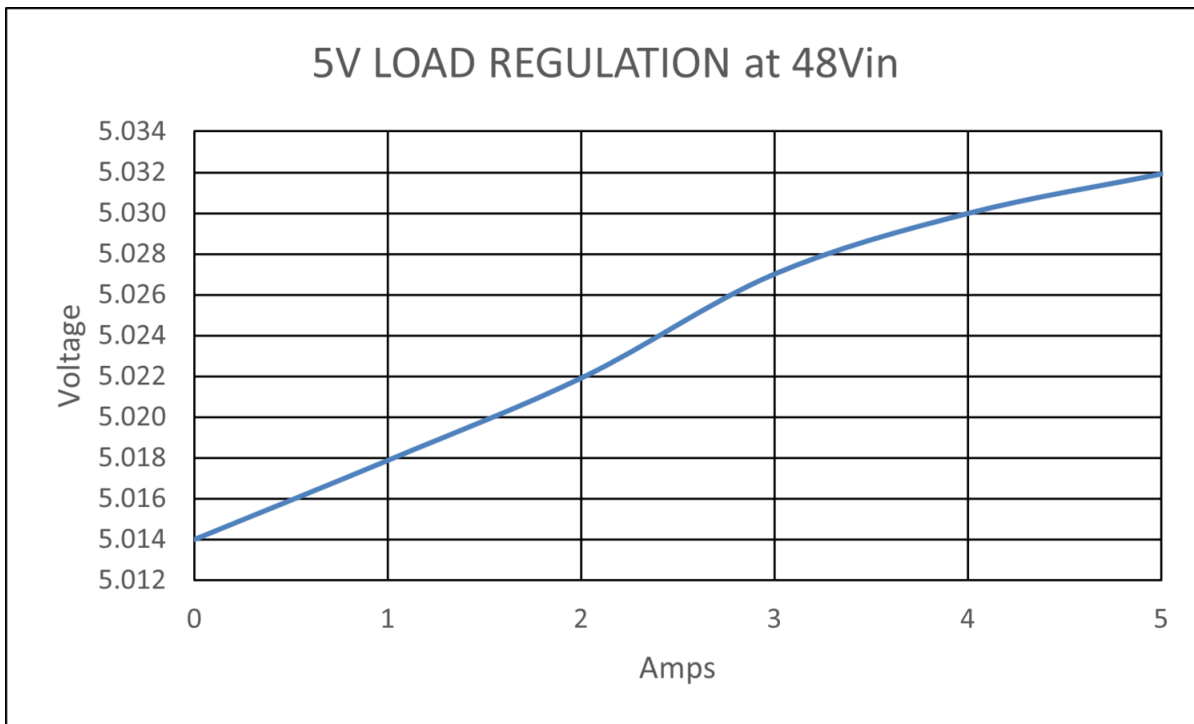


Figure 5-4. 3.3 V Output Voltage Transient Response from No Load to 5 A



The following figures show the typical output voltage load regulation.

Figure 5-5. Output Voltage as a Function of Load Current



6. Efficiency

The following section describes typical total EVB efficiency under various load levels.

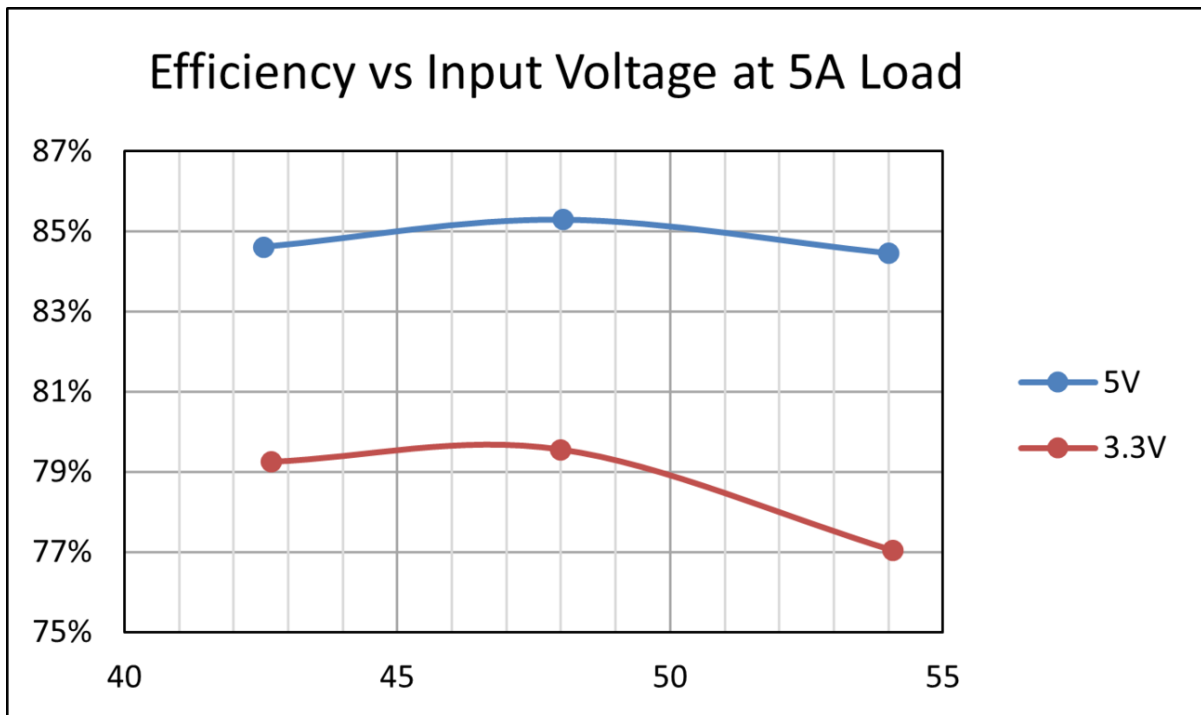
Total efficiency is measured between RJ45 input connector and output voltage connector. It includes losses in rectifier bridge, but does not include losses in the connectors.

$$\text{Total Eff} = (V_{\text{out}} \cdot I_{\text{out}}) / (V_{\text{in}} \cdot I_{\text{in}})$$

6.1 Efficiency for 48 V Input at Input Connector

The following figure shows the EV59C37A efficiency at 48 Vin.

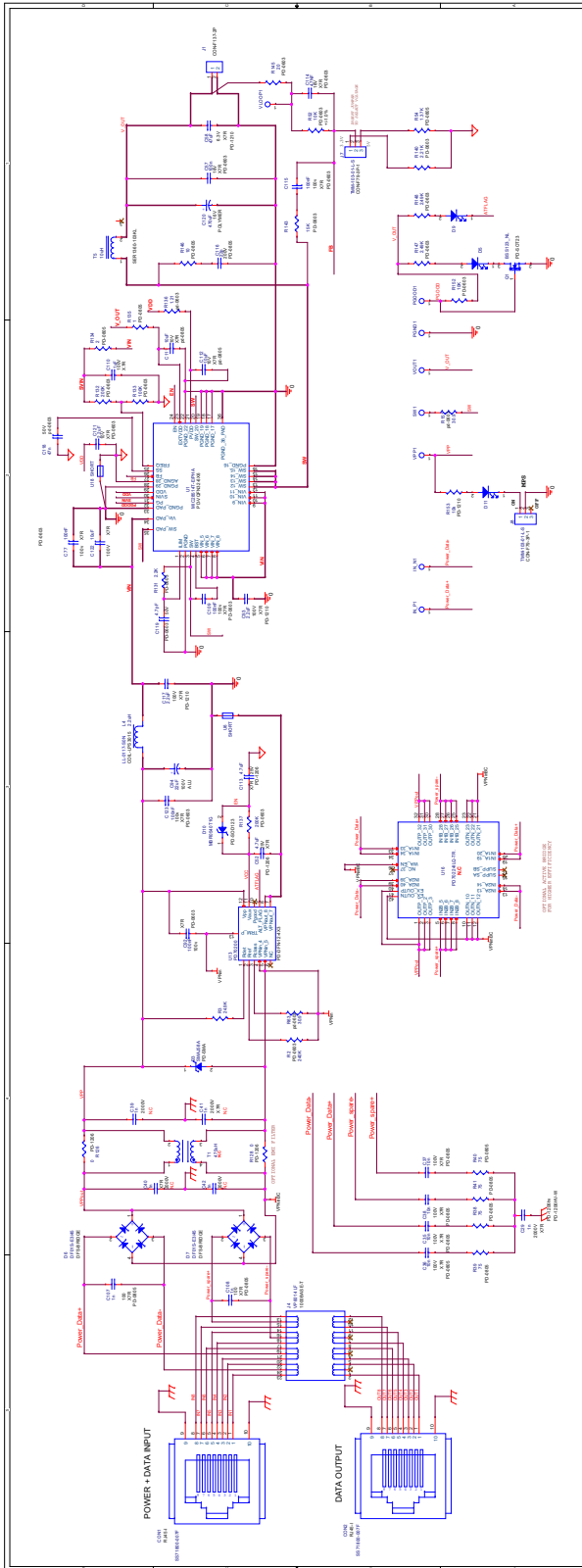
Figure 6-1. Overall EV59C37A Efficiency at 48 Vin



7. Schematic

The following figure shows the schematic of EV59C37A evaluation board.

Figure 7-1. Schematic of EV59C37A Evaluation Board



8. Bill of Materials

The following table lists the EV59C37A parts.

Table 8-1. EV59C37A Assembly

Item	Qty	Ref	VALUE	DESCRIPTION	Mfr. Part Number	Mfr. Name
1	2	CON1	RJ45	CON RJ45 SINGLE 8 POS. SHIELDED	SS71800-007F	Bel Stewart
—	—	CON2	RJ45	CON RJ45 SINGLE 8 POS. SHIELDED	SS71800-007F	Bel Stewart
2	1	C29	1 n	Capacitor 1 nF/2000 V 10% X7R 1206	1206GC102KAT1A	AVX
3	4	C35	10 n	Capacitor 10 nF 100 V 5% X7R 0805	C0805C103J1RAC	Kemet
—	—	C36	10 n	Capacitor 10 nF 100 V 5% X7R 0805	C0805C103J1RAC	Kemet
—	—	C37	10 n	Capacitor 10 nF 100 V 5% X7R 0805	C0805C103J1RAC	Kemet
—	—	C38	10 n	Capacitor 10 nF 100 V 5% X7R 0805	C0805C103J1RAC	Kemet
4	1	C52	4.7 µF	Capacitor X7R 4.7 µF 25 V 10% 1206	C1206C475K3RACTU	Kemet
5	1	C57	100 n	Capacitor 100 nF 16 V 10% X7R 0603	EMK107B7104KA-T	Taiyo Yuden
6	1	C58	47 µF	Capacitor 47 µF 6.3 V 20% X7R 1210	GRM32ER70J476ME20L	Murata
7	3	C77	100 nF	Capacitor X7R 100 nF,100 V, 10% 0603	06031C104KAT2A	AVX
—	—	C92	100 nF	Capacitor X7R 100 nF,100 V, 10% 0603	06031C104KAT2A	AVX
—	—	C123	100 nF	Capacitor X7R 100 nF,100 V, 10% 0603	06031C104KAT2A	AVX
8	2	C93	2.2 µF	Capacitor 2.2 µF 100 V 10% X7R 1210	C3225X7R2A225K	TDK
—	—	C117	2.2 µF	Capacitor 2.2 µF 100 V 10% X7R 1210	C3225X7R2A225K	TDK
9	1	C94	22 µF	Capacitor ALU 22 µF 100 V 20% 8X11.5 105C P = 3.5 mm	UPS2A220MPD1TD	Nichicon
10	2	C107	1 n	Capacitor 1 nF 100 V 5% X7R 0805	C2012X7R2A102K	TDK
—	—	C108	1 n	Capacitor 1 nF 100 V 5% X7R 0805	C2012X7R2A102K	TDK
11	2	C109	100 nF	Capacitor X7R 100 nF, 100 V, 10% 0603	CC0603KRX7R0BB104	Yageo
—	—	C115	100 nF	Capacitor X7R 100 nF, 100 V, 10% 0603	CC0603KRX7R0BB104	Yageo
12	1	C110	1 µF	Capacitor 1 µF 100 V 10% X7R 1210	12101C105KAT2A	AVX
13	2	C111	10 µF	Capacitor 10 µF 10 V 10% X7R 0805	GRM21BR71A106KE51L	Murata
—	—	C112	10 µF	Capacitor 10 µF 10 V 10% X7R 0805	GRM21BR71A106KE51L	Murata
14	1	C113	4.7 µF	Capacitor X7R 4.7 µF 25 V 10% 1206	12063C475KAT2A	AVX
15	1	C114	4.7 nF	Capacitor 4.7 nF 16 V 10% X7R 0603	C1608X7R1C472K	TDK
16	1	C116	22 p	Capacitor 22 pF 200 V 5% NPO 0805	C0805C220J2GACTU	Kemet
17	1	C118	47 n	Capacitor X7R 47 nF, 50 V, 10% 0603	CL10B473KB8NUNC	Samsung
18	1	C119	4.7 pF	Capacitor, COG, 4.7 pF, 50 V 0603	GRM1885C1H4R7CZ01D	Murata
19	1	C120	470 µF	CAP ALU POLYMER 470 UF 20% 16 V	RNE1C471MDN1PX	Nichicon
20	1	C121	2.2 µF	Capacitor X7R 2.2 µF, 10 V, 10% 0603	C1608X7R1A225K080AC	TDK
21	1	C122	10 µF	Capacitor 10 µF 100 V 20% X7R 2220	22201C106MAT2A	AVX

EV59C37A

Bill of Materials

.....continued						
Item	Qty	Ref	VALUE	DESCRIPTION	Mfr. Part Number	Mfr. Name
22	1	D3	SMAJ58A	Diode TVS 58 V 40 A SRG400WPK SMA	SMAJ58A	Vishay
23	3	D5	LED	LED SuperYelGrn 100-130o 20-40 mcd 0603 SMD	19-21-SYGCS530E3TR8	Everlight
—	—	D9	LED	LED SuperYelGrn 100-130o 20-40 mcd 0603 SMD	19-21-SYGCS530E3TR8	Everlight
—	—	D11	LED	LED SuperYelGrn 100-130o 20-40 mcd 0603 SMD	19-21-SYGCS530E3TR8	Everlight
24	2	D6	DF01S	Diode BRIDGE 100 V 1 A	DF01S-E3/45	Vishay
—	—	D7	DF01S	Diode BRIDGE 100 V 1 A	DF01S-E3/45	Vishay
25	1	D10	MBR0540	Diode SCHOTTKY 40 V 500 mA SOD123	MBR0540T1G	ON Semi
26	8	VPP1	TEST POINT	TEST POINT TIN PLATED HEAD 1.7 mm x 3 mm	HK-2-G-S05	MAC-8
—	—	VOUT1	TEST POINT	TEST POINT TIN PLATED HEAD 1.7 mm x 3 mm	HK-2-G-S05	MAC-8
—	—	VLOO P1	TEST POINT	TEST POINT TIN PLATED HEAD 1.7 mm x 3 mm	HK-2-G-S05	MAC-8
—	—	SW1	TEST POINT	TEST POINT TIN PLATED HEAD 1.7 mm x 3 mm	HK-2-G-S05	MAC-8
—	—	PGOOD1	TEST POINT	TEST POINT TIN PLATED HEAD 1.7 mm x 3 mm	HK-2-G-S05	MAC-8
—	—	PGND1	TEST POINT	TEST POINT TIN PLATED HEAD 1.7 mm x 3 mm	HK-2-G-S05	MAC-8
—	—	IN_P1	TEST POINT	TEST POINT TIN PLATED HEAD 1.7 mm x 3 mm	HK-2-G-S05	MAC-8
—	—	IN_N1	TEST POINT	TEST POINT TIN PLATED HEAD 1.7 mm x 3 mm	HK-2-G-S05	MAC-8
27	1	J1	MB332-350M02	Terminal block 2 Pole interlocking 3.5 mm pitch	MB332-350M02	Deca
28	1	J4	VP6014 LF	1000 BASE-T SINGLE PORT VOIP MAG	VP6014 LF	BOTHHAND
29	2	J7	Header	Con Male PIN Header 3P 2 mm Vertical SR TH	TMM-103-01-L-S	Samtec
—	—	J8	Header	Con Male PIN Header 3P 2 mm Vertical SR TH	TMM-103-01-L-S	Samtec
30	1	L4	2.2 µH	CAP CRM 10 nF 100 V 10% X7R 0603 SMT	C0603C103K1RACTU	Kemet
31	1	Q1	BSS123	Diode Switching 200 V 500 mA SOD123	EGL34D	Vishay
32	1	R2	240K	TVS DIODE 58VWM 93.6VC SMA	SMAJ58CA	Diodes Inc.
33	1	R3	24.9K	TVS DIODE 58VWM 93.6VC SMA	SMAJ58CA	Diodes Inc.
34	4	R38	75	Resistor 75R 125 mW 1% 0805	CR0805-FX-75R0-E	Bourns
—	—	R39	75	Resistor 75R 125 mW 1% 0805	CR0805-FX-75R0-E	Bourns
—	—	R40	75	Resistor 75R 125 mW 1% 0805	CR0805-FX-75R0-E	Bourns
—	—	R41	75	Resistor 75R 125 mW 1% 0805	CR0805-FX-75R0-E	Bourns
35	1	R52	10K	Resistor 10K 62.5 mW 1% 0603	RC1608F1002CS	Samsung
36	1	R54	1.37K	Resistor 1.37K 125 mW 1% 0805	CRCW08051K37FKEA	Vishay
37	2	R63	30.9	Resistor 30.9R 1%, 1/10 W 0603	ERJ3EKF30R9V	Panasonic
—	—	R151	30.9	Resistor 30.9R 1%, 1/10 W 0603	ERJ3EKF30R9V	Panasonic
38	2	R126	0	Resistor 0R 250 mW 5% 1206 JUMPER <0.05R	RC3216J000CS	Samsung
—	—	R128	0	Resistor 0R 250 mW 5% 1206 JUMPER <0.05R	RC3216J000CS	Samsung

EV59C37A

Bill of Materials

.....continued						
Item	Qty	Ref	VALUE	DESCRIPTION	Mfr. Part Number	Mfr. Name
39	1	R131	2.2K	Resistor 2.2K 1/10 W 5% 0603	CRCW06032K20JNEA	Vishay
40	1	R132	200K	Resistor 200K 62.5 mW 1% 0603	CRCW0603200KFKEA	Vishay
41	1	R133	100K	Resistor 100K 62.5 mW 1% 0603	CR16-1003FL	ASJ
42	1	R134	2	Resistor 2 Ω , 125 mW 1% 0805	D12002RFCS-E3	Vishay
43	1	R135	1	Resistor 1 Ω , 125 mW 5% 0805	RC2012J1R0CS	Samsung
44	1	R136	1.21	Resistor 1.21 Ω , 1%, 1/10 W 0603	RK73H1JTTD1R21F	KOA
45	1	R137	200K	Resistor 200 K 62.5 mW 1% 0603	RC0603FR-07200KL	Yageo
46	1	R140	2.21K	Resistor 2.21 K, 1%, 1/16 W 0603	RC1608F2211CS	Samsung
47	1	R143	15K	Resistor 15 K 62.5 mW 1% 0603	RC0603FR-0715KL	Yageo
48	1	R145	20	Resistor 20 Ω 5% 1/10 W 0603	ERJ3GEYJ200V	Panasonic
49	1	R146	10	Resistor 10 Ω 5% 1/8 W 0805	RC2012J100CS	Samsung
50	2	R147	2.49K	Resistor 2.49 K 62.5 mW 1% 0603	CR16-2491FL	ASJ
—	—	R148	2.49K	Resistor 2.49 K 62.5 mW 1% 0603	CR16-2491FL	ASJ
51	1	R152	10K	Resistor 10 K 62.5 mW 1% 0603	RC0603FR-0710KL	Yageo
52	1	R153	10K	Resistor 10 K 1/2 W 1% 1210	RC1210FR-0710KL	Yageo
53	1	T5	10 μ H	Inductor 10 μ H 6.2A 9.8 m Ω	SER1360-103KL	Coilcraft
54	1	U1	MIC28514T	IC Regulator 75 V/5 A w/Soft Start 32VQFN	MIC28514T-E/PHA	Microchip
55	1	U13	PD70200	AT PD IC front end PD70200	PD70200ILD	Microchip

Note:

1. Third party parts might be replaced by equivalent alternatives.

9. Board Layout

EV59C37A is a two-layer board. The layers use two-ounce copper. The following figures show the two copper layers and the silk board for tracking the device placements.

Figure 9-1. Top Layer

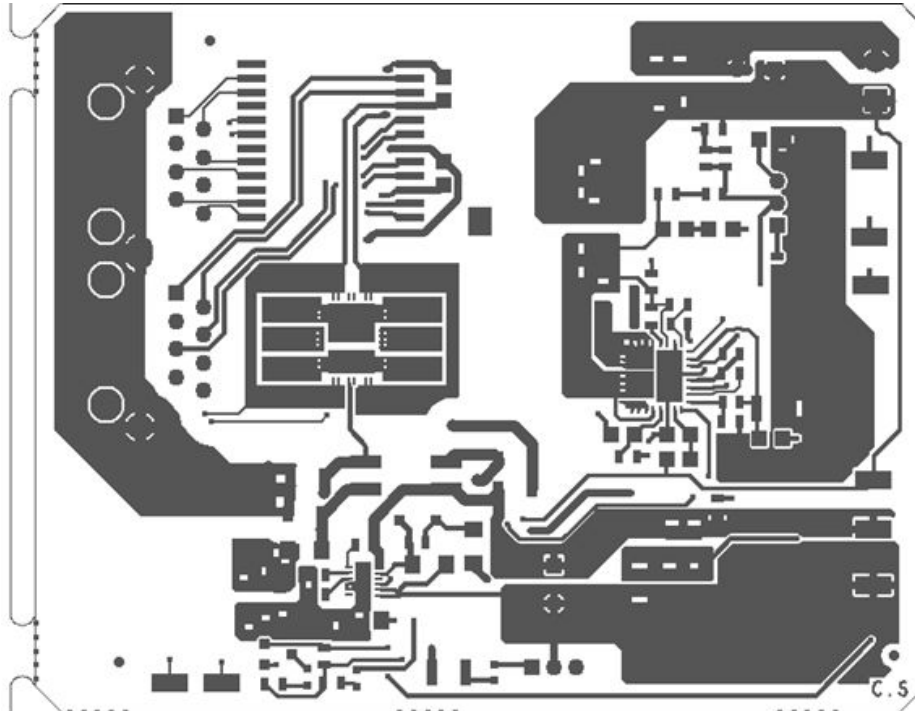


Figure 9-2. Top Silk

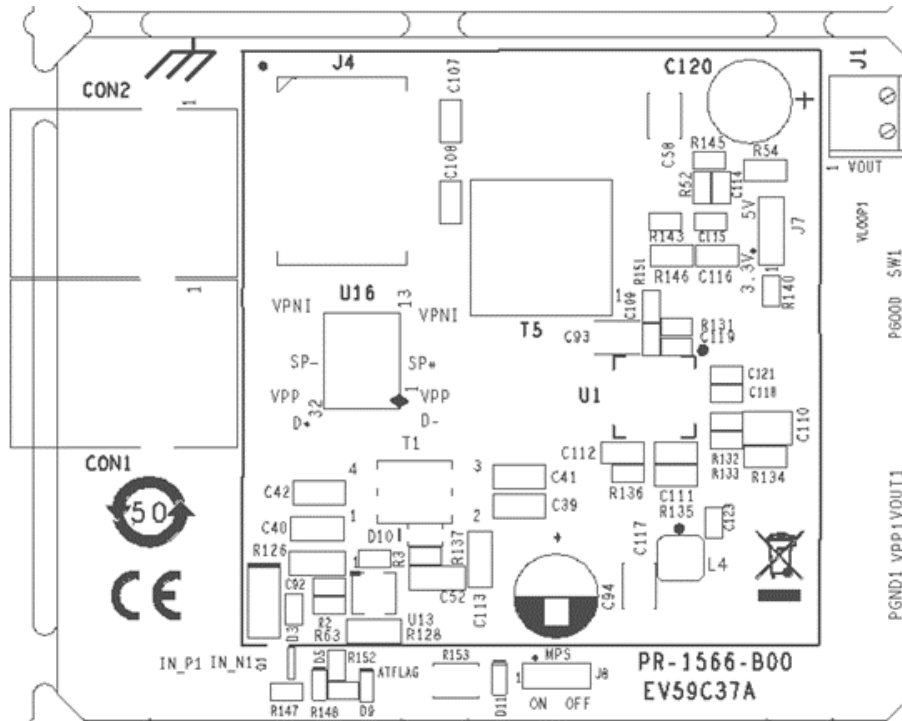


Figure 9-3. Bottom Layer

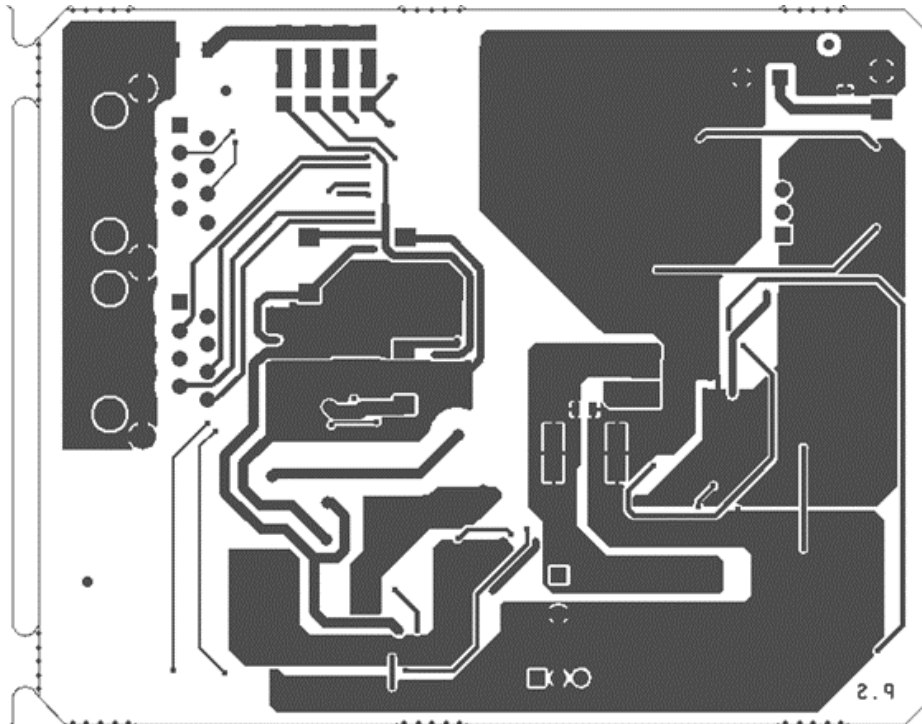
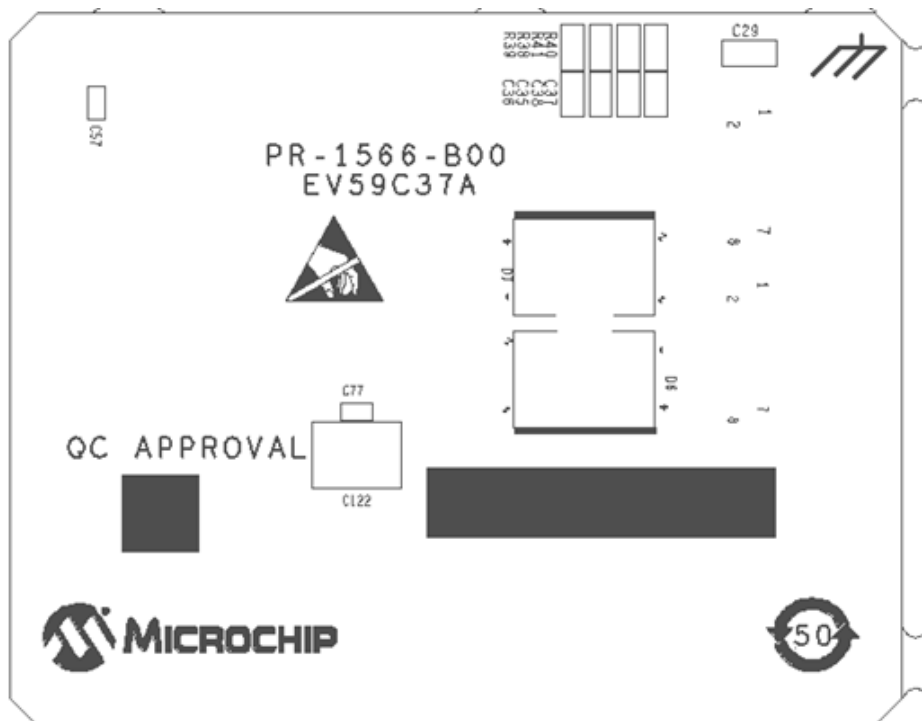


Figure 9-4. Bottom Silk



10. Revision History

Revision	Date	Description
A	05/2021	This is the initial release of the document.

The Microchip Website

Microchip provides online support via our website at www.microchip.com/. This website is used to make files and information easily available to customers. Some of the content available includes:

- **Product Support** – Data sheets and errata, application notes and sample programs, design resources, user's guides and hardware support documents, latest software releases and archived software
- **General Technical Support** – Frequently Asked Questions (FAQs), technical support requests, online discussion groups, Microchip design partner program member listing
- **Business of Microchip** – Product selector and ordering guides, latest Microchip press releases, listing of seminars and events, listings of Microchip sales offices, distributors and factory representatives

Product Change Notification Service

Microchip's product change notification service helps keep customers current on Microchip products. Subscribers will receive email notification whenever there are changes, updates, revisions or errata related to a specified product family or development tool of interest.

To register, go to www.microchip.com/pcn and follow the registration instructions.

Customer Support

Users of Microchip products can receive assistance through several channels:

- Distributor or Representative
- Local Sales Office
- Embedded Solutions Engineer (ESE)
- Technical Support

Customers should contact their distributor, representative or ESE for support. Local sales offices are also available to help customers. A listing of sales offices and locations is included in this document.

Technical support is available through the website at: www.microchip.com/support

Microchip Devices Code Protection Feature

Note the following details of the code protection feature on Microchip devices:

- Microchip products meet the specifications contained in their particular Microchip Data Sheet.
- Microchip believes that its family of products is secure when used in the intended manner and under normal conditions.
- There are dishonest and possibly illegal methods being used in attempts to breach the code protection features of the Microchip devices. We believe that these methods require using the Microchip products in a manner outside the operating specifications contained in Microchip's Data Sheets. Attempts to breach these code protection features, most likely, cannot be accomplished without violating Microchip's intellectual property rights.
- Microchip is willing to work with any customer who is concerned about the integrity of its code.
- Neither Microchip nor any other semiconductor manufacturer can guarantee the security of its code. Code protection does not mean that we are guaranteeing the product is "unbreakable." Code protection is constantly evolving. We at Microchip are committed to continuously improving the code protection features of our products. Attempts to break Microchip's code protection feature may be a violation of the Digital Millennium Copyright Act. If such acts allow unauthorized access to your software or other copyrighted work, you may have a right to sue for relief under that Act.

Legal Notice

Information contained in this publication is provided for the sole purpose of designing with and using Microchip products. Information regarding device applications and the like is provided only for your convenience and may be superseded by updates. It is your responsibility to ensure that your application meets with your specifications.

THIS INFORMATION IS PROVIDED BY MICROCHIP “AS IS”. MICROCHIP MAKES NO REPRESENTATIONS OR WARRANTIES OF ANY KIND WHETHER EXPRESS OR IMPLIED, WRITTEN OR ORAL, STATUTORY OR OTHERWISE, RELATED TO THE INFORMATION INCLUDING BUT NOT LIMITED TO ANY IMPLIED WARRANTIES OF NON-INFRINGEMENT, MERCHANTABILITY, AND FITNESS FOR A PARTICULAR PURPOSE OR WARRANTIES RELATED TO ITS CONDITION, QUALITY, OR PERFORMANCE.

IN NO EVENT WILL MICROCHIP BE LIABLE FOR ANY INDIRECT, SPECIAL, PUNITIVE, INCIDENTAL OR CONSEQUENTIAL LOSS, DAMAGE, COST OR EXPENSE OF ANY KIND WHATSOEVER RELATED TO THE INFORMATION OR ITS USE, HOWEVER CAUSED, EVEN IF MICROCHIP HAS BEEN ADVISED OF THE POSSIBILITY OR THE DAMAGES ARE FORESEEABLE. TO THE FULLEST EXTENT ALLOWED BY LAW, MICROCHIP'S TOTAL LIABILITY ON ALL CLAIMS IN ANY WAY RELATED TO THE INFORMATION OR ITS USE WILL NOT EXCEED THE AMOUNT OF FEES, IF ANY, THAT YOU HAVE PAID DIRECTLY TO MICROCHIP FOR THE INFORMATION. Use of Microchip devices in life support and/or safety applications is entirely at the buyer's risk, and the buyer agrees to defend, indemnify and hold harmless Microchip from any and all damages, claims, suits, or expenses resulting from such use. No licenses are conveyed, implicitly or otherwise, under any Microchip intellectual property rights unless otherwise stated.

Trademarks

The Microchip name and logo, the Microchip logo, Adaptec, AnyRate, AVR, AVR logo, AVR Freaks, BesTime, BitCloud, chipKIT, chipKIT logo, CryptoMemory, CryptoRF, dsPIC, FlashFlex, flexPWR, HELDO, IGLOO, JukeBlox, KeeLoq, Klear, LANCheck, LinkMD, maXStylus, maXTouch, MediaLB, megaAVR, Microsemi, Microsemi logo, MOST, MOST logo, MPLAB, OptoLyzer, PackeTime, PIC, picoPower, PICSTART, PIC32 logo, PolarFire, Prochip Designer, QTouch, SAM-BA, SenGenuity, SpyNIC, SST, SST Logo, SuperFlash, Symmetricom, SyncServer, Tachyon, TimeSource, tinyAVR, UNI/O, Vectron, and XMEGA are registered trademarks of Microchip Technology Incorporated in the U.S.A. and other countries.

AgileSwitch, APT, ClockWorks, The Embedded Control Solutions Company, EtherSynch, FlashTec, Hyper Speed Control, HyperLight Load, IntelliMOS, Libero, motorBench, mTouch, Powermite 3, Precision Edge, ProASIC, ProASIC Plus, ProASIC Plus logo, Quiet-Wire, SmartFusion, SyncWorld, Temux, TimeCesium, TimeHub, TimePictra, TimeProvider, WinPath, and ZL are registered trademarks of Microchip Technology Incorporated in the U.S.A.

Adjacent Key Suppression, AKS, Analog-for-the-Digital Age, Any Capacitor, AnyIn, AnyOut, Augmented Switching, BlueSky, BodyCom, CodeGuard, CryptoAuthentication, CryptoAutomotive, CryptoCompanion, CryptoController, dsPICDEM, dsPICDEM.net, Dynamic Average Matching, DAM, ECAN, Espresso T1S, EtherGREEN, IdealBridge, In-Circuit Serial Programming, ICSP, INICnet, Intelligent Paralleling, Inter-Chip Connectivity, JitterBlocker, maxCrypto, maxView, memBrain, Mindi, MiWi, MPASM, MPF, MPLAB Certified logo, MPLIB, MPLINK, MultiTRAK, NetDetach, Omniscient Code Generation, PICDEM, PICDEM.net, PICKit, PICtail, PowerSmart, PureSilicon, QMatrix, REAL ICE, Ripple Blocker, RTAX, RTG4, SAM-ICE, Serial Quad I/O, simpleMAP, SimpliPHY, SmartBuffer, SMART-I.S., storClad, SQL, SuperSwitcher, SuperSwitcher II, Switchtec, SynchroPHY, Total Endurance, TSHARC, USBCheck, VariSense, VectorBlox, VeriPHY, ViewSpan, WiperLock, XpressConnect, and ZENA are trademarks of Microchip Technology Incorporated in the U.S.A. and other countries.

SQTP is a service mark of Microchip Technology Incorporated in the U.S.A.

The Adaptec logo, Frequency on Demand, Silicon Storage Technology, and Symmcom are registered trademarks of Microchip Technology Inc. in other countries.

GestIC is a registered trademark of Microchip Technology Germany II GmbH & Co. KG, a subsidiary of Microchip Technology Inc., in other countries.

All other trademarks mentioned herein are property of their respective companies.

© 2021, Microchip Technology Incorporated, Printed in the U.S.A., All Rights Reserved.

ISBN: 978-1-5224-8287-1

Quality Management System

For information regarding Microchip's Quality Management Systems, please visit www.microchip.com/quality.

Worldwide Sales and Service

AMERICAS	ASIA/PACIFIC	ASIA/PACIFIC	EUROPE
<p>Corporate Office 2355 West Chandler Blvd. Chandler, AZ 85224-6199 Tel: 480-792-7200 Tel: 480-792-7277 Technical Support: www.microchip.com/support Web Address: www.microchip.com</p> <p>Atlanta Duluth, GA Tel: 678-957-9614 Fax: 678-957-1455</p> <p>Austin, TX Tel: 512-257-3370</p> <p>Boston Westborough, MA Tel: 774-760-0087 Fax: 774-760-0088</p> <p>Chicago Itasca, IL Tel: 630-285-0071 Fax: 630-285-0075</p> <p>Dallas Addison, TX Tel: 972-818-7423 Fax: 972-818-2924</p> <p>Detroit Novi, MI Tel: 248-848-4000</p> <p>Houston, TX Tel: 281-894-5983</p> <p>Indianapolis Noblesville, IN Tel: 317-773-8323 Fax: 317-773-5453 Tel: 317-536-2380</p> <p>Los Angeles Mission Viejo, CA Tel: 949-462-9523 Fax: 949-462-9608 Tel: 951-273-7800</p> <p>Raleigh, NC Tel: 919-844-7510</p> <p>New York, NY Tel: 631-435-6000</p> <p>San Jose, CA Tel: 408-735-9110 Tel: 408-436-4270</p> <p>Canada - Toronto Tel: 905-695-1980 Fax: 905-695-2078</p>	<p>Australia - Sydney Tel: 61-2-9868-6733</p> <p>China - Beijing Tel: 86-10-8569-7000</p> <p>China - Chengdu Tel: 86-28-8665-5511</p> <p>China - Chongqing Tel: 86-23-8980-9588</p> <p>China - Dongguan Tel: 86-769-8702-9880</p> <p>China - Guangzhou Tel: 86-20-8755-8029</p> <p>China - Hangzhou Tel: 86-571-8792-8115</p> <p>China - Hong Kong SAR Tel: 852-2943-5100</p> <p>China - Nanjing Tel: 86-25-8473-2460</p> <p>China - Qingdao Tel: 86-532-8502-7355</p> <p>China - Shanghai Tel: 86-21-3326-8000</p> <p>China - Shenyang Tel: 86-24-2334-2829</p> <p>China - Shenzhen Tel: 86-755-8864-2200</p> <p>China - Suzhou Tel: 86-186-6233-1526</p> <p>China - Wuhan Tel: 86-27-5980-5300</p> <p>China - Xian Tel: 86-29-8833-7252</p> <p>China - Xiamen Tel: 86-592-2388138</p> <p>China - Zhuhai Tel: 86-756-3210040</p>	<p>India - Bangalore Tel: 91-80-3090-4444</p> <p>India - New Delhi Tel: 91-11-4160-8631</p> <p>India - Pune Tel: 91-20-4121-0141</p> <p>Japan - Osaka Tel: 81-6-6152-7160</p> <p>Japan - Tokyo Tel: 81-3-6880-3770</p> <p>Korea - Daegu Tel: 82-53-744-4301</p> <p>Korea - Seoul Tel: 82-2-554-7200</p> <p>Malaysia - Kuala Lumpur Tel: 60-3-7651-7906</p> <p>Malaysia - Penang Tel: 60-4-227-8870</p> <p>Philippines - Manila Tel: 63-2-634-9065</p> <p>Singapore Tel: 65-6334-8870</p> <p>Taiwan - Hsin Chu Tel: 886-3-577-8366</p> <p>Taiwan - Kaohsiung Tel: 886-7-213-7830</p> <p>Taiwan - Taipei Tel: 886-2-2508-8600</p> <p>Thailand - Bangkok Tel: 66-2-694-1351</p> <p>Vietnam - Ho Chi Minh Tel: 84-28-5448-2100</p>	<p>Austria - Wels Tel: 43-7242-2244-39 Fax: 43-7242-2244-393</p> <p>Denmark - Copenhagen Tel: 45-4485-5910 Fax: 45-4485-2829</p> <p>Finland - Espoo Tel: 358-9-4520-820</p> <p>France - Paris Tel: 33-1-69-53-63-20 Fax: 33-1-69-30-90-79</p> <p>Germany - Garching Tel: 49-8931-9700</p> <p>Germany - Haan Tel: 49-2129-3766400</p> <p>Germany - Heilbronn Tel: 49-7131-72400</p> <p>Germany - Karlsruhe Tel: 49-721-625370</p> <p>Germany - Munich Tel: 49-89-627-144-0 Fax: 49-89-627-144-44</p> <p>Germany - Rosenheim Tel: 49-8031-354-560</p> <p>Israel - Ra'anana Tel: 972-9-744-7705</p> <p>Italy - Milan Tel: 39-0331-742611 Fax: 39-0331-466781</p> <p>Italy - Padova Tel: 39-049-7625286</p> <p>Netherlands - Druenen Tel: 31-416-690399 Fax: 31-416-690340</p> <p>Norway - Trondheim Tel: 47-72884388</p> <p>Poland - Warsaw Tel: 48-22-3325737</p> <p>Romania - Bucharest Tel: 40-21-407-87-50</p> <p>Spain - Madrid Tel: 34-91-708-08-90 Fax: 34-91-708-08-91</p> <p>Sweden - Gothenberg Tel: 46-31-704-60-40</p> <p>Sweden - Stockholm Tel: 46-8-5090-4654</p> <p>UK - Wokingham Tel: 44-118-921-5800 Fax: 44-118-921-5820</p>