



The Future of Analog IC Technology®

EV26053DQ-00A

Single-Cell 1A Linear Li-Ion Battery Charger Evaluation Board

DESCRIPTION

The EV26053DQ-00A is an evaluation board for the MP26053, a linear, high-performance single cell Li-Ion battery charger.

By integrating high voltage input protection into the charger IC, the MP26053 can tolerate an input surge up to 28V.

The MP26053 features constant current (CC) and constant voltage (CV) charging modes with programmable charge currents (200mA to 1A), Time out control battery full terminated control, thermal protection, battery temperature monitoring, reverse current blocking and trickle charge. The device also provides AC adapter power good and charge status indications to the system.

ELECTRICAL SPECIFICATION

Parameter	Symbol	Value	Units
Input Voltage	V_{IN}	5	V
Charge Current	I_{CHG}	0.8	A

FEATURES

- Input Surge up to 28V
- Adapter or USB Input
- Programmable Charge Current: 200mA to 1A
- Proprietary Over-Voltage Protection
- 0.75% V_{BATT} Accuracy
- Battery Temperature Monitoring
- AC Adapter Power Good Indicator
- Charge Status Indicator
- Battery full terminated control
- Timer off control
- Fully Assembled and Tested

APPLICATIONS

- Cell Phones
- MP3 Players
- Smart Phones
- PDAs
- Digital Cameras

"MPS" and "The Future of Analog IC Technology" are Registered Trademarks of Monolithic Power Systems, Inc.

EV26053DQ-00A EVALUATION BOARD



(L x W x H) 2.0" x 1.9" x 0.5"
(5.0cm x 4.8cm x 1.2cm)

Board Number	MPS IC Number
EV26053DQ-00A	MP26053DQ

I-V Charge Curve

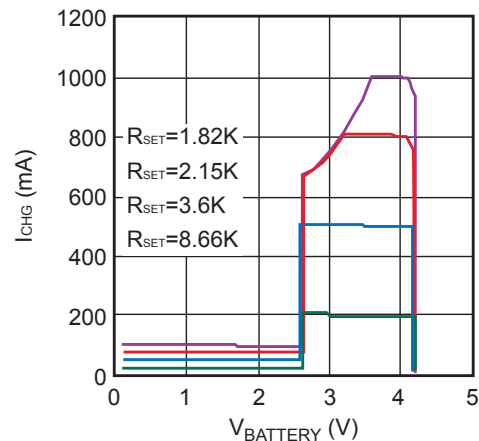

EVALUATION BOARD SCHEMATIC

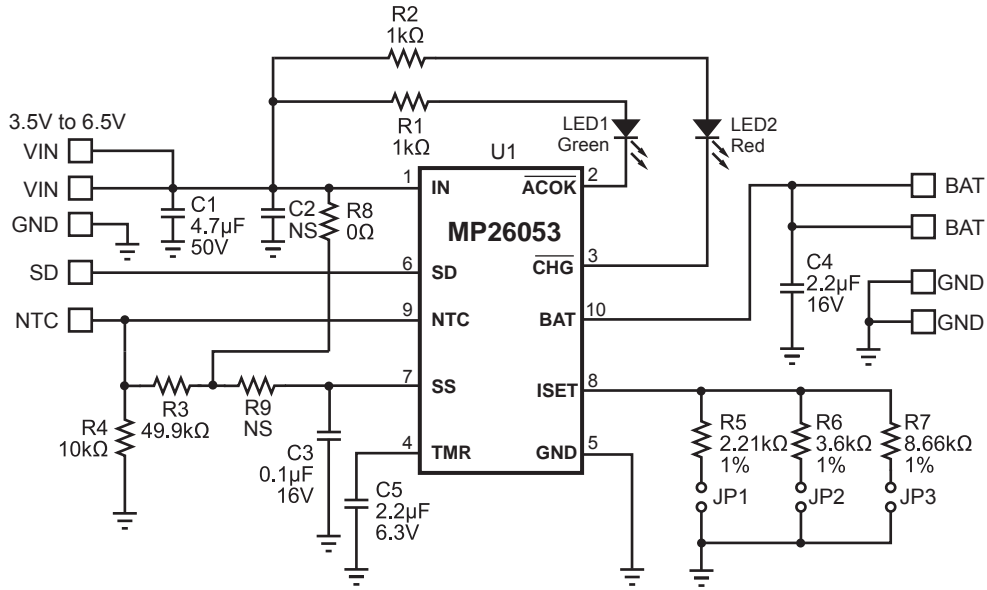

EV26053DQ-00A BILL OF MATERIALS

Qty	Ref	Value	Description	Package	Manufacturer	Manufacturer P/N
1	C1	4.7μF	Ceramic Cap, 50V, X7R	1210	Murata	GRM32ER71H475K
					Holystone	C1210B475M035T
	C2	NS		1206		
1	C3	0.1μF	Ceramic Cap, 16V, X7R	0603	Murata	GRM188R71C104K
1	C4	2.2μF	Ceramic Cap, 16V, X7R	1210	Murata	GRM32MR71C225K
1	C5	2.2μF	Ceramic Cap, 6.3V, X7R	0805	Murata	GRM21BR70J225K
1	JP1,2,3		3x2-Pin Connector Header, 0.100"		Molex	10-89-1601
1	LED1		Led Green, Surface Mount	0805	Panasonic	LNJ306G5URA
1	LED2		Led Red, Surface Mount	0805	Panasonic	LNJ206R5RRX
2	R1, R2	1kΩ	Film Res, 5%	0603	Panasonic	ERJ-3GEYJ102V
1	R3	49.9kΩ	Film Res, 1%	0603	Panasonic	ERJ-3EKF4992V
1	R4	10kΩ	Film Res, 1%	0603	Panasonic	
1	R5	2.21kΩ	Film Res, 1%	0603	Panasonic	ERJ-3EKF2211V
1	R6	3.6kΩ	Film Res, 1%	0603	YAGEO	9C06031A3601FKHFT
1	R7	8.66kΩ	Film Res, 1%	0603	Panasonic	ERJ-3EKF8661V
1	R8	0Ω	Film Res, 5%	0603	YAGEO	9C06031A0000FKHFT
	R9	NS				
1	U1		Linear Charger	QFN10	MPS	MP26053DQ

PRINTED CIRCUIT BOARD LAYOUT

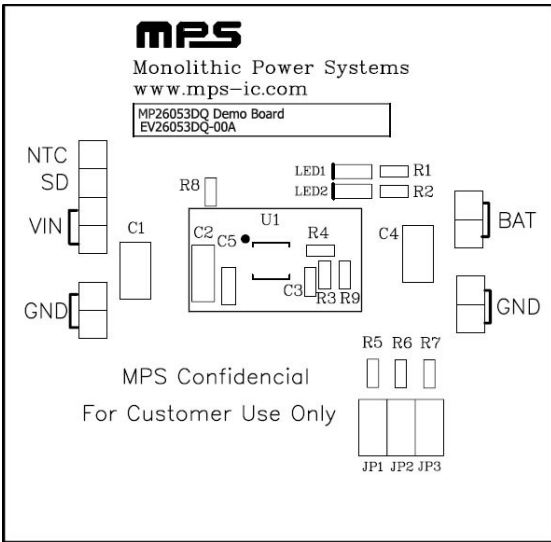

Figure 1—Top Silk Layer

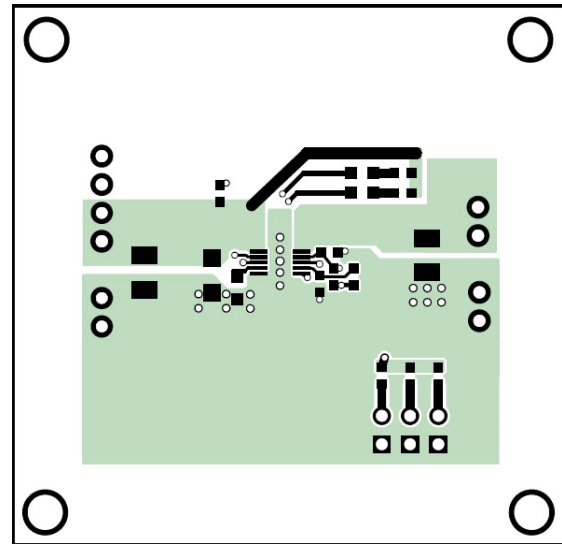

Figure 2—Top Layer

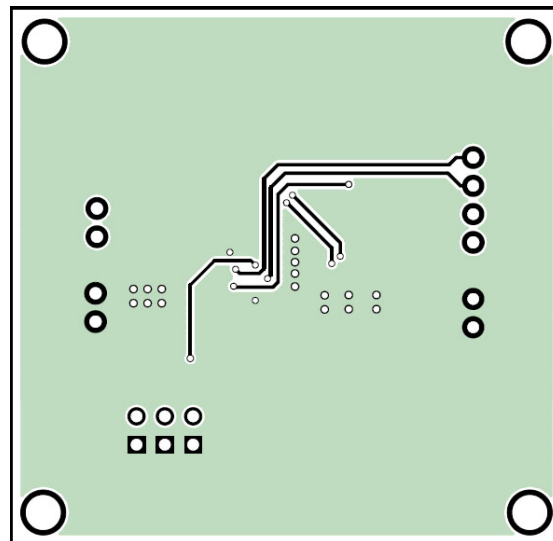

Figure 3—Bottom Layer

QUICK START GUIDE

The output voltage on this board is preset to 4.2V (for a single cell battery). The board layout accommodates most commonly used capacitors.

The LEDs are power indicators. When LED1 is on, the 5V input is present (LED1 is off when the input is disconnected). When LED2 is on, the battery is charging, and when the battery is full or there is no battery connected, LED 2 will turn off.

1. Set the charge current I_{CHG} using the jumpers JP1, JP2 and JP3 per the following table:

JP1	JP2	JP3	I_{CHG}
X		X	1000mA
X			800mA
	X	X	700mA
	X		500mA
		X	200mA

Where "X" indicates a connection.

2. Attach the positive and negative ends of the load to the VOUT and GND pins, respectively.
3. Attach the input voltage ($V_{IN}=5V$) and the input ground to the VIN and GND pins, respectively.
4. Set the Timer C5 (μF):

$$T_{(SEC)} = 22 \times 10^3 \times C_5$$

NOTICE: The information in this document is subject to change without notice. Please contact MPS for current specifications. Users should warrant and guarantee that third party Intellectual Property rights are not infringed upon when integrating MPS products into any application. MPS will not assume any legal responsibility for any said applications.