

## BIAS DRIVER

MECL MC350 series

### MC354

Bias driver that compensates for changes in circuit parameters with temperature.

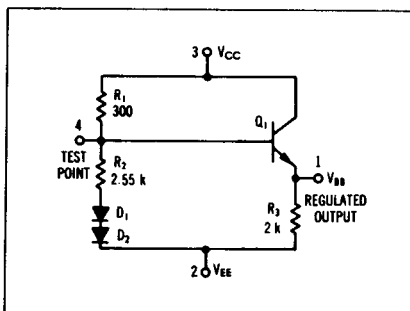

## ELECTRICAL CHARACTERISTICS

Characteristic	V <sub>EE</sub> Pin No	I <sub>L</sub> Pin No	Ground Pin No	Symbol Pin No in ( )	Test Conditions						Unit
					V <sub>dc</sub> ± 1%						
					0°C		+25°C		+75°C		
Power Supply Brake Current	2	—	3	I <sub>S</sub> (2)	—	4.8	—	4.4	—	4.0	mAdc
Output Voltage	2	1 ⊕	3	V <sub>out</sub>	-1.14	-1.27	-1.09	-1.22	-1.04	-1.18	V <sub>dc</sub>

Pins not listed are left open.

⊕ Current test conditions: no load = 0; full load = -2.5 mAdc ± 5%.

## CIRCUIT DESCRIPTION

### Circuit Operation:

The divider network  $R_1$ ,  $R_2$ ,  $D_1$ ,  $D_2$  compensates for temperature variations of the base-emitter voltages of  $Q_1$ , and of the driven gates, producing a bias voltage for the MECL logic circuits that maintains a constant set of dc operating conditions over the temperature range of 0 to +75°C. In addition, compensation for power supply variations is achieved, since the bias output voltage is derived from the system supply.

Either of the supply voltage nodes may be used as ground, however the ground potential of the bias driver must coincide with that of the logic system. Thus, if  $V_{CC}$  is grounded in the logic system, then —

$$V_{CC} = 0; \quad V_{EE} = -5.2 \text{ V}; \\ V_{out} = -1.15 \text{ nominal output voltage at } 25^\circ\text{C}$$