



Draft Copy for Review

Microsystems for Biometrics

FingerTIP™

FTF 1100 MF1 V2.0

CMOS Chip and System



This document contains information on a new product. Details are subject to change without notice.

Important Further information is confidential and may be obtained on request.
Please contact:
Infineon Technologies AG, Germany,
Security and Chip Card ICs
Fax +49 (0)89 234-22308, E-Mail: fingertip.tm@infineon.com

**Published by Infineon Technologies AG, CC Applications Group
St.-Martin-Straße 76, D-81541 München**

© Infineon Technologies AG 2000 All Rights Reserved.

Attention please!

As far as patents or other rights of third parties are concerned, liability is only assumed for components, not for applications, processes and circuits implemented within components or assemblies.

The information describes the type of component and shall not be considered as assured characteristics.

Terms of delivery and rights to change design reserved.

For questions on technology, delivery, and prices please contact Infineon Technologies Group Offices in Germany or the Infineon Technologies Representatives world-wide (see address list).

Due to technical requirements components may contain dangerous substances. For information on the types in question please contact your nearest Infineon Technologies Office.

Infineon Technologies AG is an approved CECC manufacturer.

Packing

Please use the recycling operators known to you. We can also help you – get in touch with your nearest sales office. By agreement we will take packing material back, if it is sorted. You must bear the costs of transport.

For packing material that is returned to us unsorted or which we are not obliged to accept, we shall have to invoice you for any costs incurred.

Components used in life-support devices or systems must be expressly authorized for such purpose!

Critical components ¹⁾ of Infineon Technologies AG, may only be used in life-support devices or systems ²⁾ with the express written approval of the Infineon Technologies AG.

- 1) A critical component is a component used in a life-support device or system whose failure can reasonably be expected to cause the failure of that life-support device or system, or to affect its safety or effectiveness of that device or system.
- 2) Life support devices or systems are intended (a) to be implanted in the human body, or (b) to support and/or maintain and sustain human life. If they fail, it is reasonable to assume that the health of the user may be endangered.

Contents

1	INTRODUCTION	6
1.1	Validity of the Manual	6
1.2	Revision History	6
1.3	Related Documentation	6
2	OVERVIEW	7
2.1	Features of the FingerTIP™	7
2.2	Functional Block Diagram of the FingerTIP™	8
2.3	Dynamics of the Sensor	9
2.4	Fingerprint Image Readout	11
2.5	Sleep Mode	12
2.6	Selecting EPP 1.9 or SPI Mode	12
2.7	Switch-on Sequence of the FingerTIP™	12
2.8	Defect Rate	12
3	THE PARALLEL INTERFACE EPP 1.9	13
3.1	Basic Information on the Parallel Interface	13
3.2	EPP Register Definitions	14
3.3	EPP 1.9 Signal Definitions	14
3.4	Timing of the EPP 1.9 Protocol Used by the FingerTIP™	15
3.5	Selecting the EPP Mode	16
3.6	Resetting the Pixel Pointer and Changing the Dynamics in EPP Mode	16
3.7	Set the FingerTIP™ into Sleep Mode in EPP Mode	16
3.8	Fingerprint Image Readout	17
3.9	Pinout of the FingerTIP™ in EPP Mode	18
3.10	Recommended Electrical Connection of the FingerTIP™ in EPP Mode	20
4	THE SERIAL INTERFACE SPI	21
4.1	Basic Information on the Serial Interface SPI	21
4.2	Pin Description of the SPI Interface	22
4.2.1	EPP/SPI	22

4.2.2	Chip Select (/CS)	22
4.2.3	Serial Input (SI)	22
4.2.4	Serial Output (SO)	23
4.2.5	Serial Clock (SCK)	23
4.3	SPI Protocol and Timing	24
4.4	The FingerTIP™ SPI Commands	26
4.4.1	Command: Set Mode	27
4.4.2	Command: Reset Pointer	27
4.4.3	Command: Read Status	28
4.4.4	Command: Read Data	28
4.5	Fingerprint Image Readout	29
4.6	Pinout of the FingerTIP™ in SPI Mode	30
4.7	Recommended Electrical Connection of the FingerTIP™ in SPI Mode	32
5	ELECTRICAL CHARACTERISTICS AND PIN DESCRIPTION	33
5.1	FingerTIP™ Electrical Characteristics	33
5.2	Static Pad Characteristics	34
5.3	Pin Description	35
6	MODULE	36
6.1	Module Dimensions and Material	36
7	FINGERTIP™ SDK SOFTWARE AND BIOMETRIC ALGORITHMS	37
7.1	Enrollment	37
7.2	Verification	37
8	LITERATURE	38
9	INDEX	39

1 Introduction

This document describes the FingerTIP™ and its features. Chapter 2 describes the function of the FingerTIP™. The following chapters explain the EPP and SPI interface of the sensor and its timing characteristics. Chapter 5 outlines the electrical characteristics. The module dimensions are shown in chapter 6. The last chapter contains general information on the SDK software package for fingerprint recognition available from Infineon Technologies.

1.1 Validity of the Manual

This *FingerTIP™ Data Book* is valid for sensor devices FTF 1100 MF1.

1.2 Revision History

Date	Revision	
04.00	3.3	Added revision history
		Changed ESD references from 8kV to 12kV maximum
		Added section 3.10 Recommended connection in EPP mode
		Added section 4.7 Recommended connection in SPI mode
		Changed section 2.1 to reference enhanced sensor surface process

1.3 Related Documentation

The *Design-In Guideline /2/* of the FingerTIP™ contains information on the electrical and mechanical design-in and describes for example how to minimize the influence of ESD air discharge. We strongly recommend reference to this document in your design for precautionary measures and attributes.

2 Overview

The FingerTIP™ is available as a module. The module consists of the sensor chip in a plastic package with a metal frame and a flexible PCB (Printed Circuit Board). Biometric algorithms are also available on request.

2.1 Features of the FingerTIP™

Measuring technique	capacitive sensor in CMOS technology
Resolution	224 x 288 pixels (513 dpi); data format: 8 bit/pixel
Image capture and readout time ¹	< 100ms (in EPP mode @ $V_{CC} = 4.5V - 5.5V$; $T = 25^{\circ}C$) < 110ms (in SPI mode @ $V_{CC} = 4.5V - 5.5V$; $T = 25^{\circ}C$) < 140ms (in SPI mode @ $V_{CC} = 3.3V - 4.5V$; $T = 25^{\circ}C$)
Usable gray levels (dynamics)	approx. 70 or approx. 40 (programmable)
Interface	parallel interface $\leq 1MHz$ (EPP 1.9 protocol) serial interface (SPI $\leq 5MHz$ [$V_{CC} = 4.5V - 5.5V$] res. $\leq 4MHz$ [$V_{CC} = 3.3V - 4.5V$])
Supply voltage	EPP: $V_{CC} = 4.5V - 5.5V$ SPI: $V_{CC} = 3.3V - 5.5V$
Power consumption	EPP: < 5mW / typ. 50mW (sleep/readout mode, 1MHz, $V_{CC}=5V$) SPI: < 5mW / typ. 50mW (sleep/readout mode, 5MHz, $V_{CC}=5V$)
ESD protection ²	12kV air discharge on the sensor surface
Mechanical resistance ³	ultra hard surface provides protection against 'ruboff' and scratches on the sensor surface
Chemical resistance ³	Enhanced resistance against most liquids, gases and sweat with advanced surface fabrication process
Size	sensor area: 11.1mm x 14.3mm module: 21.0mm x 18.0mm x 1.5mm, flexible PCB: 45.9mm
Module package	PPS plastic housing with metal frame and a PI PCB interconnect (meets flammability standard UL94V0)
Module connector	flexible 21-wire PCB with 0.5 mm pitch
Life cycle	> 100,000 tips > 0.8 years readout mode, 3 years sleep mode and 10 years storage
Operating temperature	- 40°C < T < +85°C (non condensing)
Storage temperature	- 40°C < T < +125°C (non condensing)

¹ The total system reaction time would including the image capture and readout time as well as fingerprint identification. Therefore this time depends mainly on the processor performance, the algorithms used for identification and the image capture speed. With the Infineon FingerTIP™ SDK running on an 400MHz PC this time is usually less than 500ms.

² This value is guaranteed only for the FingerTIP™ module if the notes of the Design-In Guideline are observed.

³ Details see qualification report.

2.2 Functional Block Diagram of the FingerTIP™

The block diagram (**figure 1**) shows the structure of the FingerTIP™. The sensor surface is made of an environmental resistant material that protects a matrix of 224 x 288 metal electrode pixels. The measurement technology used is capacitive and outputs an 8-bit value per pixel.

Figure 2 illustrates the capacitive measurement technology: The capacitance C_P is formed by a single metal electrode (pixel) and the finger that constitutes the second electrode. Valleys and ridges on the finger will yield varying C_P values. C_P is too small for direct measurement, therefore C_P is measured indirectly. C_P is charged (SW1 is closed and SW2 is open) and discharged (SW1 is open and SW2 is closed) up to 255 times. The voltage of C_C increases with each charge cycle. The charge stored in C_P is proportional to the capacitance of C_P .

The voltage of C_C is compared with the reference voltage V_{ref} . If both values are equal, the value of the 8-bit counter, which counts the number of charge cycles, is stored and the charge cycle ends. This value represents the gray level of the pixel of a fingerprint. Two values of V_{ref} can be selected to allow different ranges of usable gray levels (section 2.3).

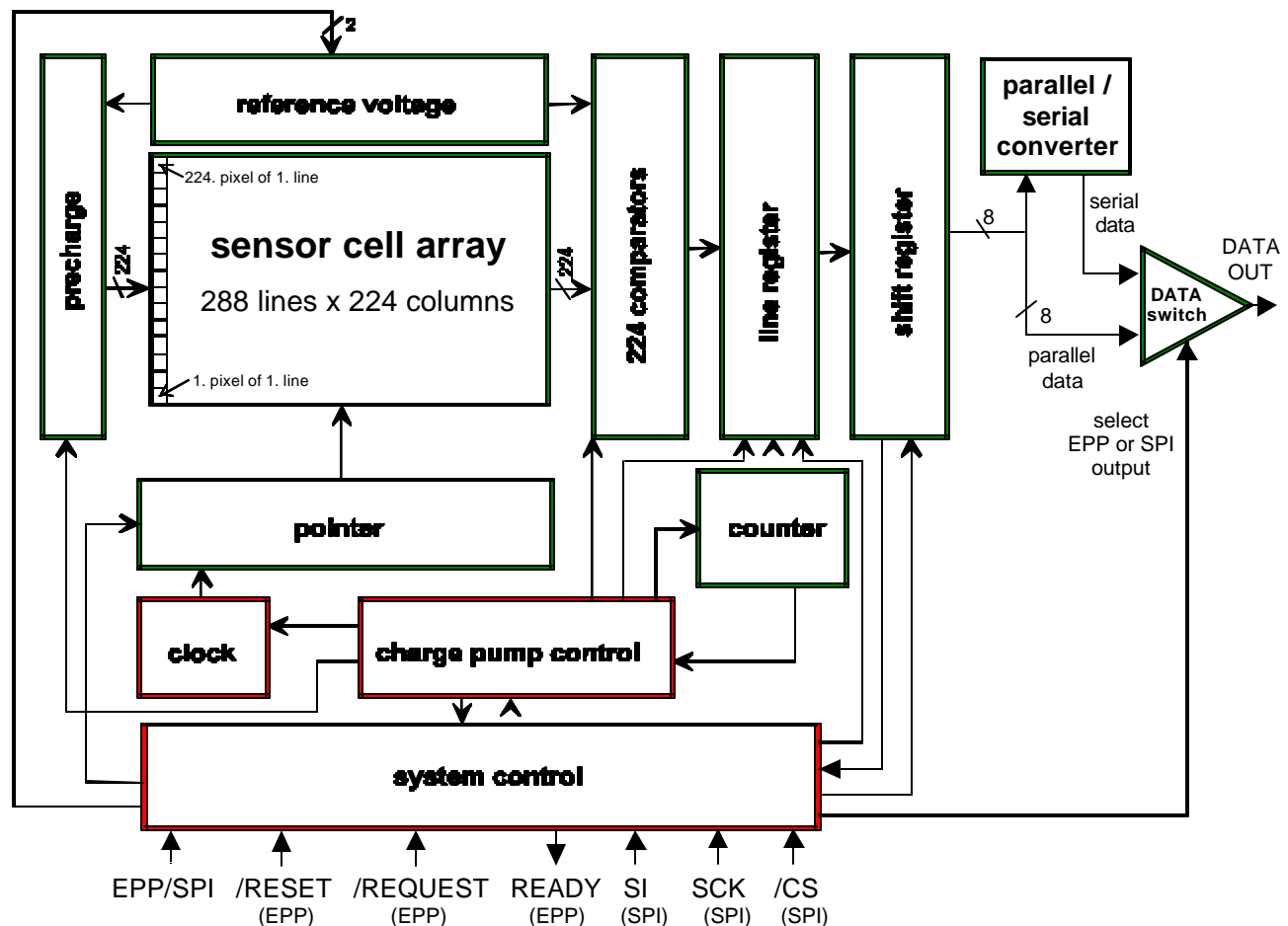

Figure 1: Functional Block Diagram FingerTIP™

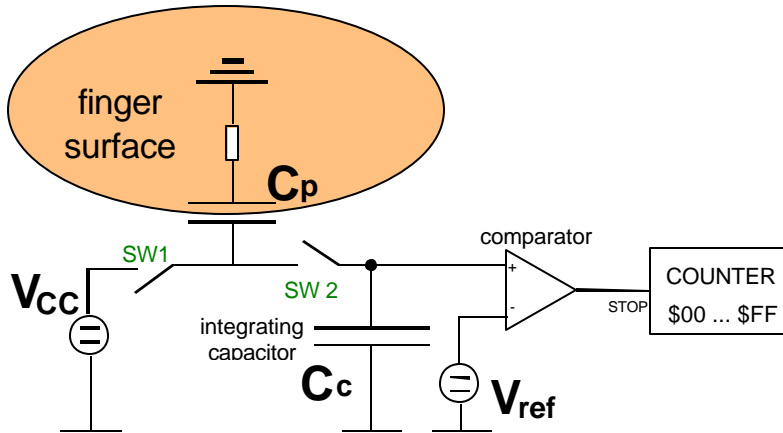

Figure 2: FingerTIP™: Capacitive Measurement Technique

In each charge cycle one line with 224 pixels is acquired. These 224 8-bit values are first stored in the line register. In a second step the data is transferred to the shift register. The output lines of the shift register are connected to the data switch and the parallel to serial converter. Depending on the selected mode – EPP or SPI – the DATA switch unit connects the corresponding input line to the output line (EPP: parallel output, SPI: serial output). While the values are being transferred from the shift register to the output unit, the next line is evaluated. Once the shift register has output all the 224 bytes, a 225th byte with the value 00h is added to signal the line end. When all the lines are output the FingerTIP™ continues to output a sequence of 225 bytes (224 x FFh and 1 x 00h).

2.3 Dynamics of the Sensor

The FingerTIP™ provides an 8-bit representation of the gray levels for each pixel. In terms of image processing, the value 0 represents black and the value 255 white. In reality, the gray level representation of a fingerprint will be limited by the so called *water line* and *air line* as shown in the schematic histogram (**figure 3**).

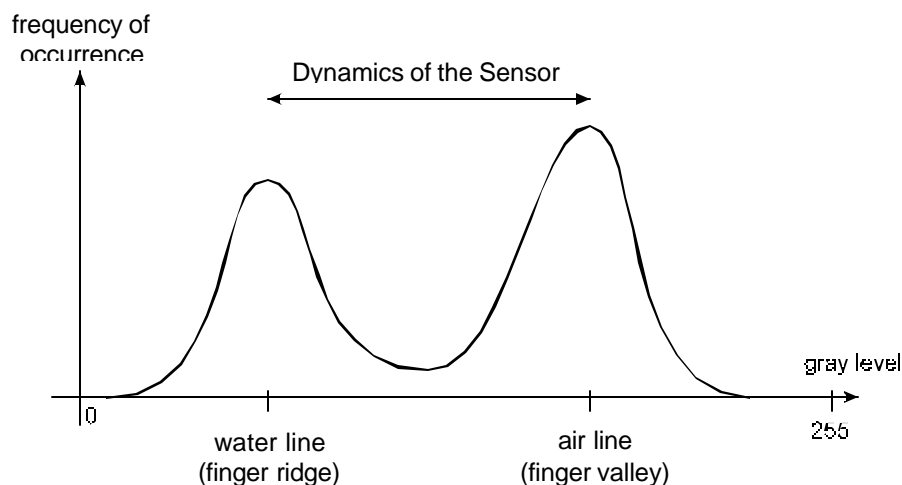

Figure 3: Schematic Histogram of the FingerTIP™

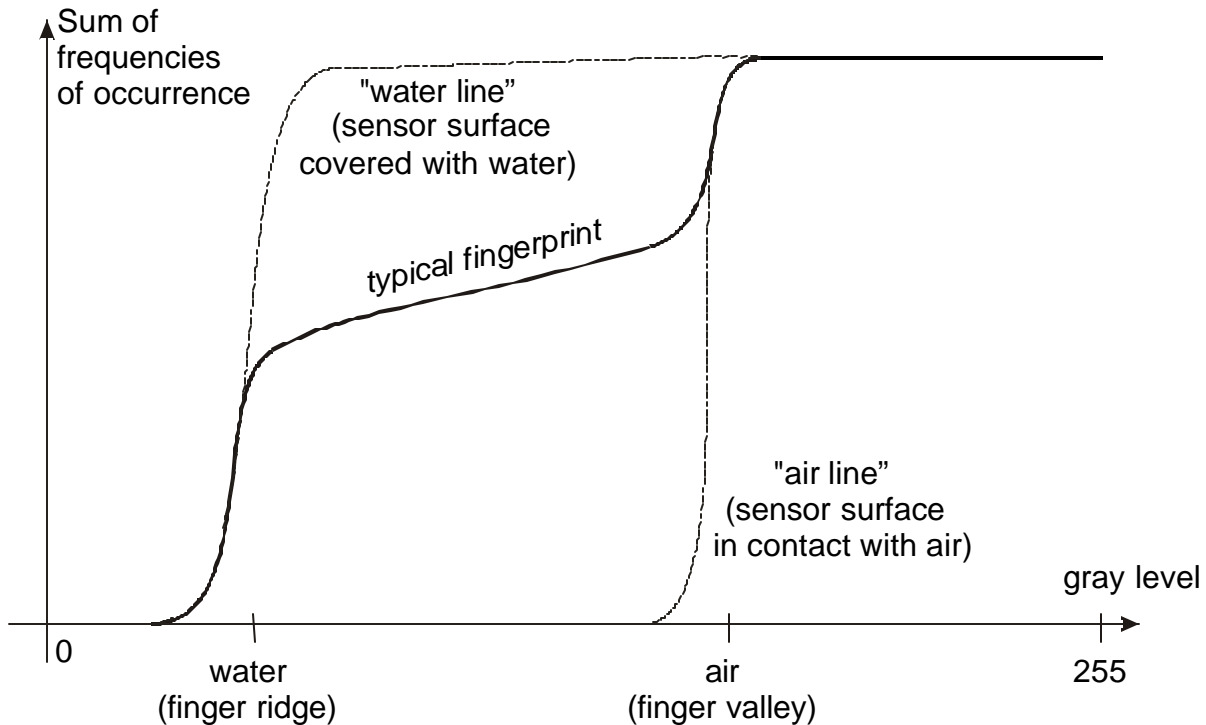

Figure 4: The Corresponding Sum-Histogram

The maximum obtainable local contrast is determined by the maximum difference between the gray levels of finger valleys (air) and finger ridges (skin moisture). This local contrast is called *dynamics*.

An alternative representation of the gray levels is the so-called sum-histogram, which is generated from the fingerprint histogram (shown in **figure 3**) by integration over all gray levels. A diagram of the sum-histogram is shown in **figure 4**.

The so-called *water line* appears when the sensor surface is covered with water. If the surface is in contact with air, the *air line* appears. A typical fingerprint will be somewhere between these two characteristic lines and is illustrated in **figure 4**.

The dynamics of the sensor depends on the internal reference voltage V_{ref} (**figure 2**). Two values of V_{ref} are selectable to allow the sensor to be adapted to different requirements. **Table 1** shows the number of usable gray levels. The procedure to change the dynamics is shown in section 3.6 for EPP mode and section 4.41 for SPI mode.

Supply voltage V_{CC}	High dynamics		Low dynamics	
	V_{ref}	usable gray levels	V_{ref}	usable gray levels
5.0 V	3.6 V	approx. 70	2.5 V	approx. 40

Table 1: Reference Voltages and the Resulting Values for Dynamics

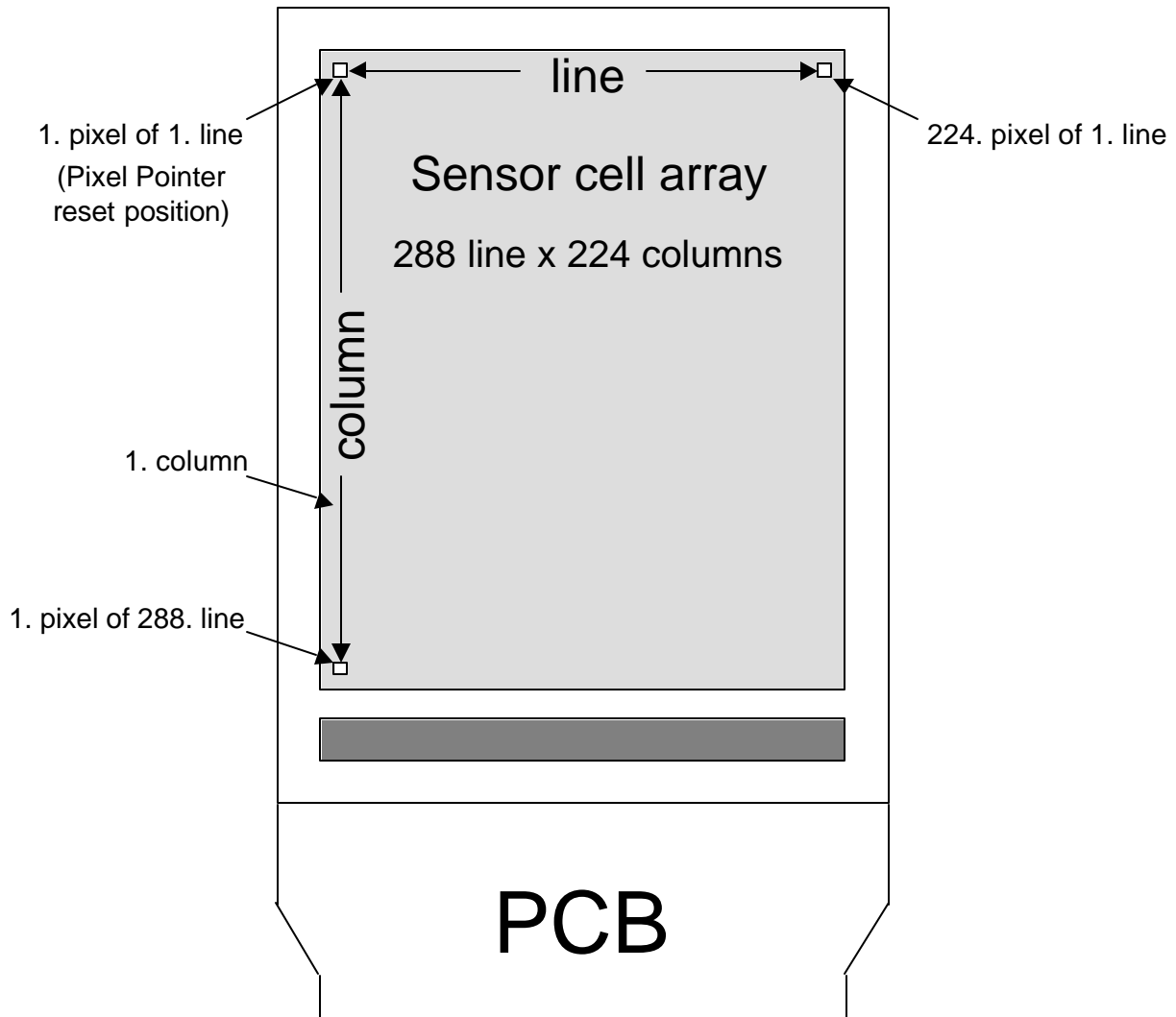

Figure 5: Pixel Position on the FingerTIP™

2.4 Fingerprint Image Readout

The fingerprint image consists of 288 x 224 pixels. Each pixel is represented by an 8-bit value. **Figure 5** shows the position of pixel (1,1) and the definition of lines and columns in the sensor field. When the readout is started (see chapter 3 and 4 for details), the image is transferred line by line starting with the first line. Each line is read out byte by byte (a pixel is represented by one byte) starting with pixel 1. An extra byte with the value 00h is added to each line, signaling the end of the line. This byte is called *LineEndMark*. Once the whole image is read out, the FingerTIP™ continuously outputs a sequence of 225 bytes (224 x FFh and 1 x 00h). The complete procedure for resetting the pixel pointer and reading out the image is explained in chapters 3 and 4.

It is recommended to check the *LineEndMark* after every line read. Chapters 3 and 4 gives some hints for a failure analysis.

2.5 Sleep Mode

The FingerTIP™ offers a power saving mode called *sleep mode*. In this mode the power consumption of the sensor is reduced to about 10% of the power consumption in *readout mode* (chapter 5.1, table 13). The life time of the sensor will be extended if it is switched to this mode (see section 2.1). Therefore it is recommended to switch the sensor to *sleep mode* whenever no readout of an image is necessary. When the sensor is switched back to *readout mode*, a new fingerprint can be acquired immediately. Section 3.7 (for EPP) and section 4.4 (for SPI) explain how to switch the sensor to sleep mode.

2.6 Selecting EPP 1.9 or SPI Mode

The EPP/SPI input pin of the FingerTIP™ is used for selecting the EPP 1.9 or SPI mode. Before power-on, the EPP/SPI pin must be set to GND to select SPI mode. Accordingly, the EPP/SPI pin must be set to V_{CC} to select EPP 1.9 mode by using a pull-up resistor. The mode can not be changed after power-on. Therefore the logic level of this input must not be changed over the time of power on.

2.7 Switch-on Sequence of the FingerTIP™

The FingerTIP™ has a built-in power-on reset. Therefore no external reset signal is needed for a sensor reset. The RESET pin of the FingerTIP™ is only active in EPP mode and is needed for resetting the pixel pointer of the sensor cell field to pixel position (1,1) and for changing the dynamics.

2.8 Defect Rate

Usually all biometric software including our *FingerTIP™ Software Package* can handle line and column defects of captured fingerprints. Up to three line or column defects and up to 50 single pixel defects are allowed in the cell field of the FingerTIP™.

3 The Parallel Interface EPP 1.9

This chapter describes the parallel interface of the FingerTIP™ and how to read out an image, change the dynamics and set sleep mode. First the data transfer protocol, electrical and timing parameters of the sensor's EPP mode, which is compatible to the IEEE 1284 standard, is described. Next the readout procedure will be explained using a block diagram. Finally, the pinout of the sensor's parallel port is shown.

For further information for design-in the sensor, please refer to the *Design-In Guideline /2/*.

3.1 Basic Information on the Parallel Interface

The FingerTIP™ offers an EPP 1.9 compatible parallel interface according to the IEEE 1284 standard. The IEEE 1284 defines five different data transfer modes: Standard Mode (SPP), Nibble Mode, Byte Mode, Extended Capabilities Port Mode (ECP) and Enhanced Parallel Port Mode (EPP). Only the ECP and EPP modes use a hardware-implemented handshake for data transfer. This leads to high data rates of at least 1MByte/s. The FingerTIP™ has an EPP 1.9 compatible interface which is easy to implement on the PC side and which can easily be emulated by a microcontroller/processor. Please note that the older version EPP 1.7, which does not meet the IEEE 1284 standard, is not supported by the FingerTIP™.

If not already done, the EPP 1.9 mode can be enabled on the PC by entering the BIOS setup menu or by using a BIOS setup utility program. The FingerTIP™ cannot be used on printer ports which do not support EPP 1.9.

The sensor represents a level-two EPP device, which is designed for high data rates according to IEEE 1284.

The IEEE 1284 standard specifies four different modes for EPP 1.9: Read data, write data, write address and read address. The FingerTIP™ only supports the read data cycle. Therefore the sensor uses only two handshake lines (nDataStb/REQUEST and nWait/READY) and 8 data lines. An additional line (nReset/RESET) is used for resetting the sensor's pixel pointer, selecting the sleep mode and for changing the dynamics. The following sections describe the timing, signal definition and protocol.

More background information on the EPP parallel port protocol can be found, for example, in the book *Parallel Port Complete /3/*

3.2 EPP Register Definitions

The PC printer port uses five I/O addresses in EPP mode. As the EPP can emulate an SPP the first three addresses 0,1 and 2 (offset to the base_address of the printer port, for example 378h for LPT1) are used by SPP. The addresses 3 and 4 are used by the EPP. As the FingerTIP™ only supports read cycles, address 4 is needed. By executing a single I/O read instruction on [base_address + 4], the PC EPP controller will generate the necessary handshake signals to transfer one data byte from the sensor to the PC. For more information please refer to the *Design-In Guideline /2/*.

3.3 EPP 1.9 Signal Definitions

Table 2 describes the EPP signals and shows their corresponding SPP signals used by the FingerTIP™.

FingerTIP Signal	SPP Signal	EPP Signal	Direction	Description
/RESET	nInit	nReset	PC → FTIP	Reset pixel pointer Activate sleep mode Change dynamics
/REQUEST	nAutoLF	nDataStrb	PC → FTIP	Start read cycle (low active)
READY	Busy	nWait	FTIP → PC	Data valid (low active)
DA0-DA7	D1-D8	AD1-AD8	FTIP → PC	Data Lines
Vss	Ground	Ground		Ground

Table 2: Signal Definition of the FingerTIP™ (FTIP) in EPP 1.9 Mode

Table 3 shows the EPP pin names and the connection between the FingerTIP™ and the printer port. Note that a one by one connection of the sensor and the printer port is not recommended. Some PCs use weak output drivers for the handshake lines. This results in poor signal quality if long cables are used between sensor and printer port. For more information please refer to the *Design-In Guideline /2/*.

FingerTIP Signal	Pin No. Sensor	SPP Signal	Pin No. EPP Port
/RESET	4	nInit	16
/REQUEST	5	nAutoLF	14
READY	6	Busy	11
DA0-DA7	9-16	D1-D8	2-9
Vss	2,19	Ground	18-25

Table 3: Pin Connection Between the FingerTIP™ and the Printer Port

3.4 Timing of the EPP 1.9 Protocol Used by the FingerTIP™

Figure 6 shows the EPP protocol for a data read cycle and the timing. **Table 4** shows the values of the timing parameters. The pad characteristics are described in chapter 5.

After a reset, which sets the pixel pointer to position (1,1), readout of the first byte can be started. A readout cycle is started when the /REQUEST line switches to low. The sensor outputs the data byte and switches the READY line to high if the data is valid. In the next step the PC reads the data byte and afterwards sets the /REQUEST line to high. Now the sensor switches the READY line to low and the data lines change to tristate. Now a new readout cycle can be started. During readout of the image no reset is needed.

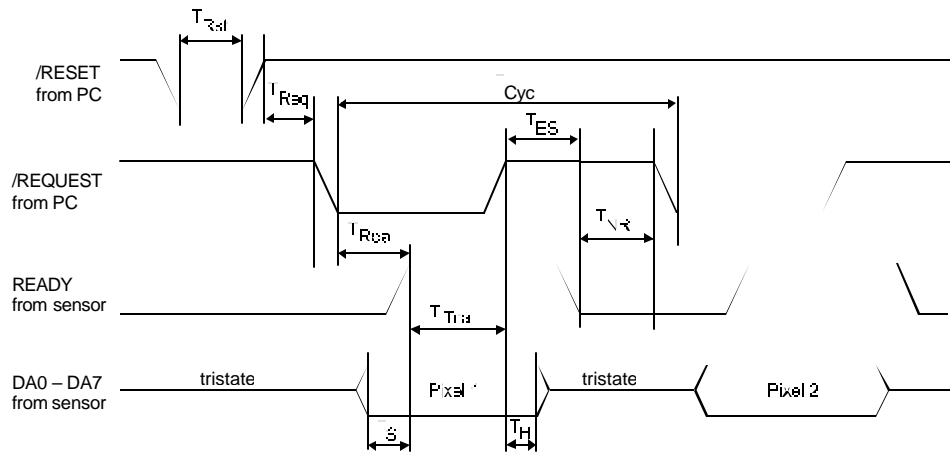

Figure 6: EPP Timing Diagram of the FingerTIP™. I/O Level: TTL Compatible

Interval	Name	Min.	Typ.	Max.	Dependency [PC or Sensor]
	Power-on reset			80 μ s	
T_{Rst}	Reset impulse	2 μ s			Reset [PC]
T_{Req}	Reset to request	300 μ s			[PC]
T_S	Data setup time	10 ns	50 ns	100 ns	Data setup time [Sensor]
T_H	Data hold time			100 ns	Data hold time [Sensor]
T_{Rea}	Request to ready		600 ns	700 ns	Response time valid data [Sensor]
T_{Tra}	Transfer time		200 ns		Transfer data to PC [PC]
T_{ES}	Deadlock time		50 ns	125 ns	[Sensor]
T_{NR}	Next read	30 ns			[Sensor]
T_{Cyc}	Transfer of 1 Byte		$\leq 1.0 \mu$ s		[PC / Sensor]
t_{RO}/t_{FO}	Output Rise/Fall Time	0.20 V/ns	0.50 V/ns	0.80 V/ns	@ $C_{I/O_Line} = 50$ pF
t_{RI}/t_{FI}	Input Rise/Fall Time	0.05 V/ns	0.50 V/ns	0.80 V/ns	@ $C_{I/O_Line} = 50$ pF

Table 4: Timing Parameters; Typical Values for 1MHz EPP Clock Frequency ($V_{CC} = 5V$)

3.5 Selecting the EPP Mode

When power is switched on, the EPP/SPI pin must be set to V_{CC} for selecting the EPP mode. It is recommended to connect the EPP/SPI pin to V_{CC} by using a pull-up resistor. It is not possible to change from SPI to EPP mode without switching power off and on. If the sensor is in EPP mode, the EPP/SPI pin must be at high level all the time.

3.6 Resetting the Pixel Pointer and Changing the Dynamics in EPP Mode

In EPP mode the dynamics can only be changed using the /RESET line. Please note that via the /RESET signal the dynamics can be changed only from low to high but not vice versa. To change the dynamics to low, the complete image must be read out. After the last byte of the image has been read out, the sensor resets its internal dynamics register. Now the dynamics is set to low by default. With the following reset only the pixel pointer is set to position (1,1) – the dynamics is still low. The next (optional) reset also sets the pixel pointer to position (1,1) and additionally changes the dynamics to high (**figure 7**). Further resets only set the pixel pointer to position (1,1) but do not change the dynamics which remains high.

Note that switching on the sensor while reset is low can be interpreted as the first reset. In this case, the next reset will change the dynamics to high. If the images must be read out in low dynamics, the image from the first readout should not be used.

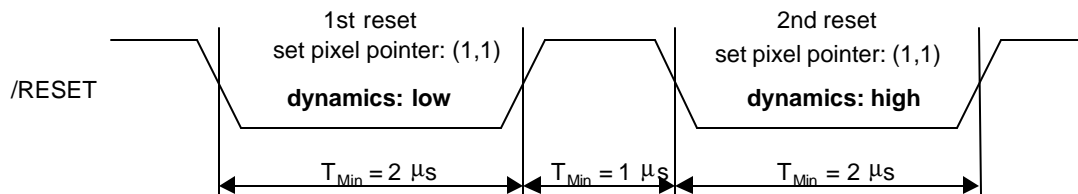

Figure 7: Changing the Dynamics to high after Readout of the Complete Image

3.7 Set the FingerTIP™ into Sleep Mode in EPP Mode

The FingerTIP™ offers a *sleep mode* to save power and increase the life time of the sensor. In EPP mode the sensor can be switched to *sleep mode* by pulling down the reset line for more than $2 \mu s$ as shown in **figure 8**. Therefore it is recommended to switch the sensor to *sleep mode* whenever there is no readout of an image. When the sensor is switched back to *readout mode*, a new fingerprint can be acquired immediately.

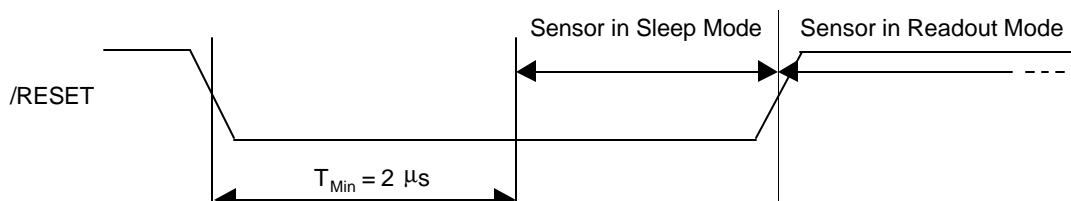

Figure 8: Set the Sensor to Sleep Mode

3.8 Fingerprint Image Readout

The following **figure 9** shows the block diagram for a readout of the sensor in EPP mode.

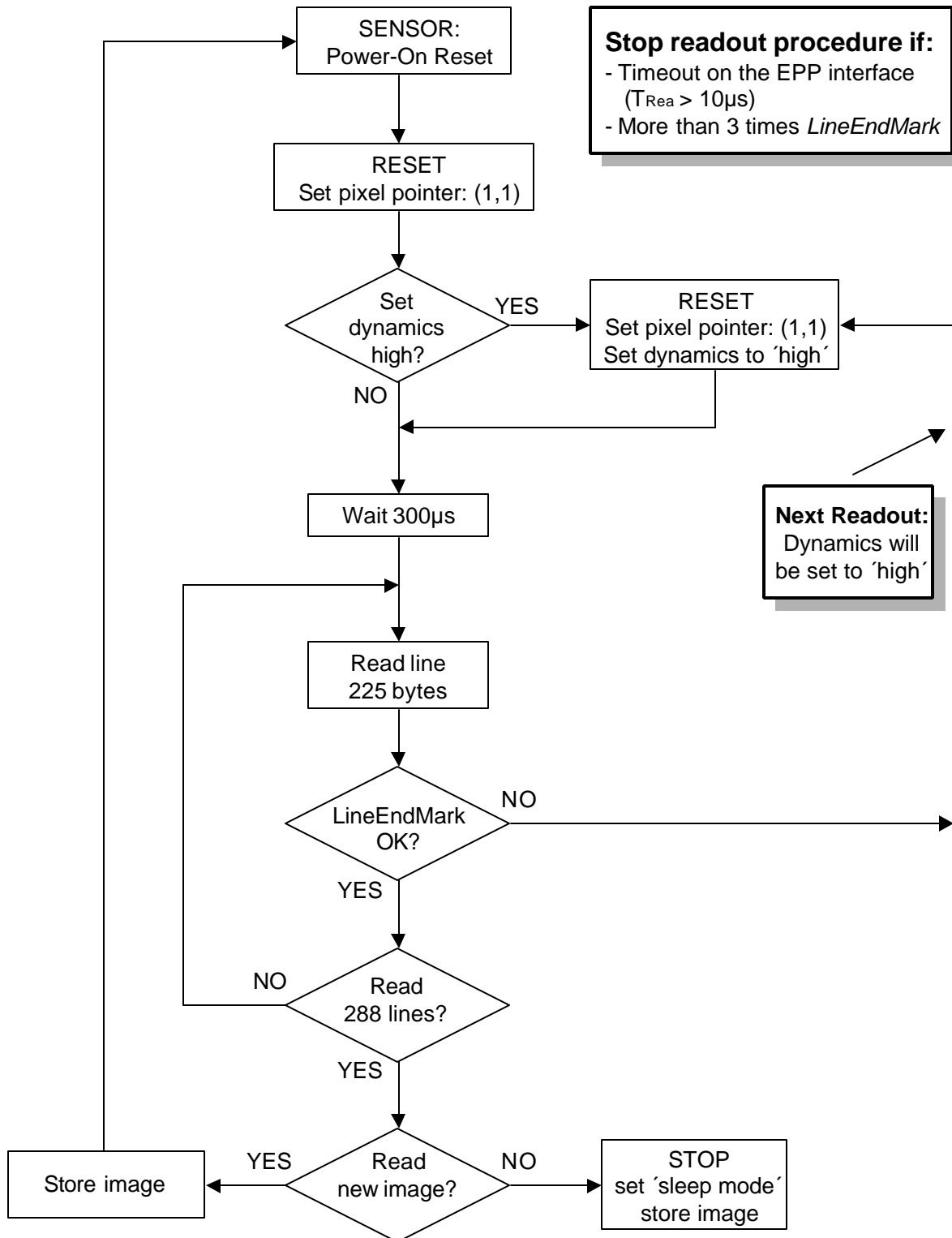

Figure 9: Block Diagram for Image Readout in EPP Mode

Once the sensor has completed its power-on reset (see **table 4**), the readout of the fingerprint image can be started. Before the first byte is read, the pixel pointer must be set to position (1,1) (see **figure 7**). This is done by a reset impulse (low active) with T_{Rst} length (see **table 4**). With a second reset the sensor can be set into high dynamics mode (see section 3.6). Then the first byte of the image can be read out. 225 EPP read cycles are needed for reading a complete line. The 225th byte of each line is the *LineEndMark* and must be 00h. Interference such as ESD air discharge and alike can force double clocking on the sensor under special conditions and the *LineEndMark* may not be 00h. Usually this kind of interference is singular and temporary. Therefore it is recommended to start reading a new image. Note that the dynamics is now high because the image was not read out completely (see section 3.6). After 64800 (225 x 288) EPP read cycles the whole image is read out.

If more than three readouts have failed because of *LineEndMark* error, the read out should be stopped in order to analyze the error. It is also recommended to check for timeout errors of the EPP port. If $T_{EL} > 10\mu s$ the readout should be stopped and the error should be analyzed. For more information and error handling please see the *Design-In Guideline /2/*.

Once the image readout is finished and the sensor is not needed for the moment, the sensor should be set to *sleep mode*.

3.9 Pinout of the FingerTIP™ in EPP Mode

In **figure 10**, the pinout of the FingerTIP™ module is shown. **Table 5** shows the pin names, the pin direction and gives a short description of the pins.

Some of the pins are multi-functional pins, depending on the selected interface mode – EPP or SPI. Chapter 5 gives a complete overview of the pins for EPP and SPI mode. The pad characteristics are also shown in chapter 5.

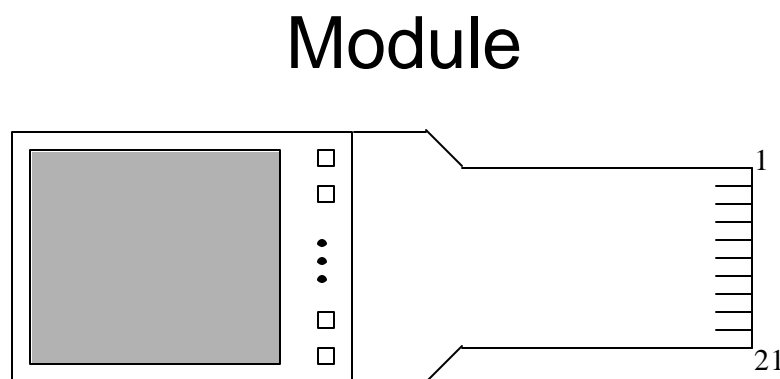

Figure 10: Pinout of the FingerTIP™ Module

Pad no.	Signal Direction	Signal Name	Active	Description
1		Prot. GND		Protective Ground
2		V _{SS}		Signal Ground
3	Input	EPP/SPI		Select Interface Mode: V _{CC} *: EPP 1.9; V _{SS} : SPI
4	Input	/RESET	Low	Reset pixel pointer to position (1,1) Change the Dynamics
5	Input	/REQUEST	Low	Start a Readout of a Byte
6	Output	READY	High	Indicates valid data on DA0 to DA7 (tristate in sleep mode)
7		Not used		Do not connect
8		Not used		Do not connect
9	Output	DA0		Data line DA0 (tristate if not active)
10	Output	DA1		Data line DA1 (tristate if not active)
11	Output	DA2		Data line DA2 (tristate if not active)
12	Output	DA3		Data line DA3 (tristate if not active)
13	Output	DA4		Data line DA4 (tristate if not active)
14	Output	DA5		Data line DA5 (tristate if not active)
15	Output	DA6		Data line DA6 (tristate if not active)
16	Output	DA7		Data line DA7 (tristate if not active)
17		Not used		Do not connect
18		Not used		Do not connect
19		V _{SS}		Signal Ground
20		V _{CC}		Supply voltage
21		Prot. GND		Protective Ground

* using a 22K pull-up resistor

Table 5: Module Pin Description for EPP 1.9 Mode

3.10 Recommended Electrical Connection of the FingerTIP™ in EPP Mode

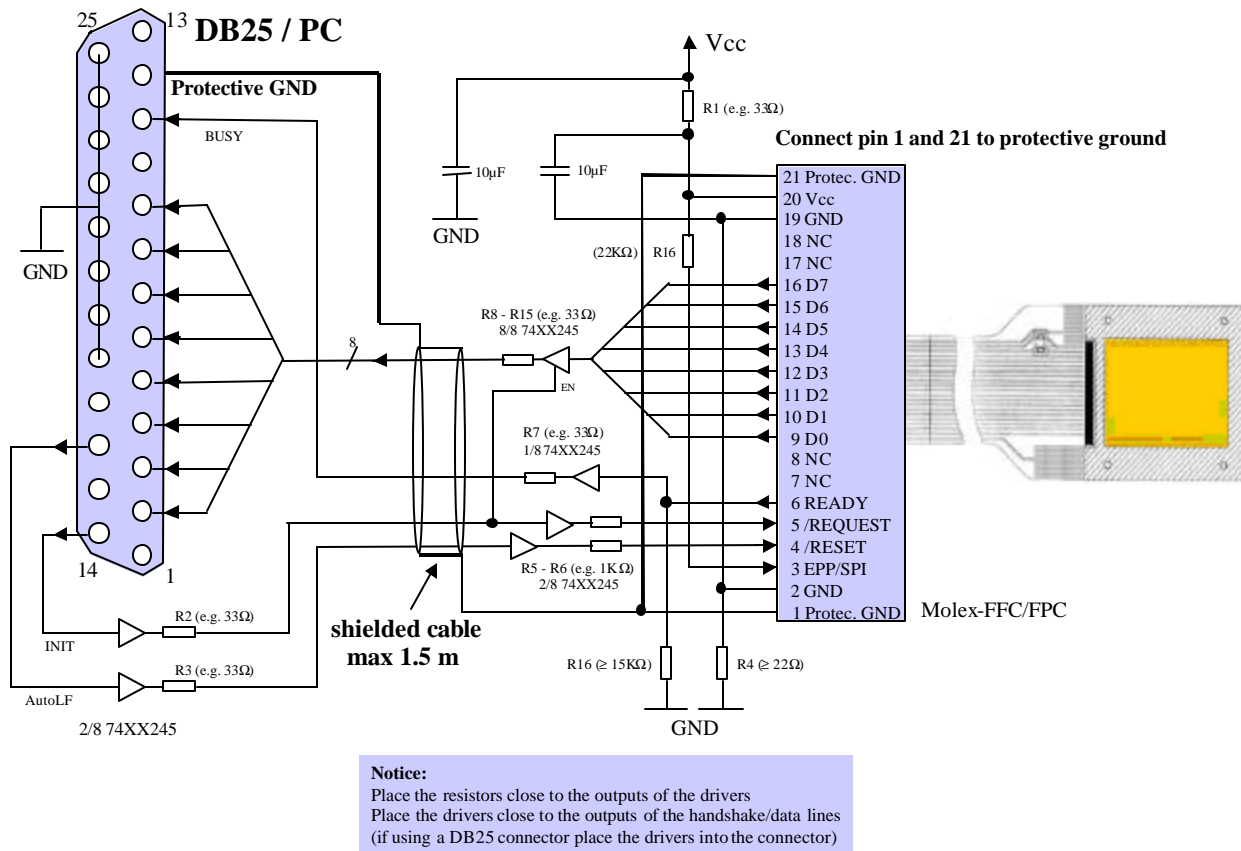

Figure 11: Recommended circuit for interfacing the FingerTIP™ to an EPP Printer Port

The recommended circuit consists of 3 parts. The first consists of the drivers and resistors between the DB-25 connector and the cable. The drivers are required to buffer the RESET (AutoLF) and REQUEST (Init) handshake lines in the case of weak PC output drivers. This is done to compensate for any potential PC signal issues. The serial resistors after the drivers are required to reduce signal ringing. The value of these resistors is dependent on the drivers used, but typical values are 330hm.

The second part is the cable. For a proper data transfer the cable must be shielded, and the maximum length should be less than 1.5 meters. To guarantee clean signal quality it is recommended to use several ground path wires to the PC chassis. On the sensor side of the cable, the shield must be connected to pin 1 and 21 (protective ground) with a dedicated line. Never connect the signal ground to protective ground on sensor side. This connection configuration of the shield is required for optimal ESD protection.

The third part of the recommended circuit is consists of the drivers and resistors between the cable and the 21-pin sensor-connector. The resistors R1 and R4 are required for both supply current limitation and ESD protection. The drivers in the data and ready lines decouple these lines from the EPP port. The combination of driver and resistor in the RESET and REQUEST line limits a possible supply current of the sensor via these I/O pins. The values of R5 and R6 will be dependent on the maximum output current of the drivers, so it is recommended to choose such a combination of driver and resistor such that the maximum current per handshake line is $< 5\text{mA}$.

For stabilising the sensor power supply, capacitors C1 and C2 are required.

4 The Serial Interface SPI

This chapter describes the serial interface of the FingerTIP™ and how to read out an image, change the dynamics and set sleep mode. First the basic interface information, the data transfer protocol and electrical and timing parameters of the sensor's SPI mode are described. Then the readout procedure is illustrated by a block diagram. Finally, the pinout of the sensor's SPI mode is shown.

For further information to design-in the sensor, please refer to the *Design-In Guideline /2/*.

4.1 Basic Information on the Serial Interface SPI

The FingerTIP™ Serial Peripheral Interface (SPI) can be operated with a clock rate of up to 5 MHz depending on the supply voltage (see **table 7**). Every command sent by the master is confirmed with a response from the sensor. The on-chip SPI interface allows bus protocols for the SPI modes (0,0) and (1,1). With the rising edge of the clock the SPI interface reads data from the SI pin while the SPI interface outputs data on the SO pin with the falling edge of the clock. The data format of the commands, the corresponding responses and the image data is 8-bit with LSB first. The SPI interface is implemented as a 3-line bus consisting of input, output and clock signals plus a chip-select line. This allows Multi-Master and Slave operation with bus-compliant systems.

4.2 Pin Description of the SPI Interface

The following table (**table 6**) shows the SPI pin names and their corresponding pins on the FingerTIP™ side.

SPI Pin Name	FingerTIP™ Pin Name	Direction	Function
	EPP/SPI	Master → FTIP	SPI Mode: Set to V_{SS}
/CS	DA2/CS	Master → FTIP	Chip Select
SO	DA3/SO	FTIP → Master	Serial Output
SI	DA0/SI	Master → FTIP	Serial Input
SCK	DA1/SCK	Master → FTIP	Serial Clock

Table 6: SPI Pin Names

4.2.1 EPP/SPI

When power is switched on, the EPP/SPI pin must be set to ground for selecting the SPI mode. It is not possible to change from EPP to SPI mode without switching power off and on. If the sensor is in SPI mode, the EPP/SPI pin must be at low level all the time.

4.2.2 Chip Select (/CS)

With the *Chip Select* (/CS) the FingerTIP™ can be selected (low active). Therefore this input must be set to low to select the sensor. After power-on and before a command can be sent, the sensor must be selected with a high-to-low transition on pin /CS. Otherwise no instructions are accepted. The sensor must be selected throughout the entire command cycle. Between two command sequences the sensor must be deselected with a high level on the /CS input. Before the sensor is selected, the *Serial Clock* (SCK) must be set to low for a minimum of t_{LCS} (see **table 7**). Otherwise the sensor will not be selected.

If the sensor is deselected, the *Serial Output* SO is tristate. This allows more than one SPI devices on the same bus.

4.2.3 Serial Input (SI)

The *Serial Input* (SI) is used to receive data from the master. The data will be accepted with the rising edge of the clock. The data format is 8-bit, starting with the LSB.

4.2.4 Serial Output (SO)

The *Serial Output* (SO) is used to send data to the master. Data will be output with the falling edge of the clock in an 8-bit format, starting with the LSB for the command response and the image data. If the sensor is not selected the *Serial Output* is set to tristate mode.

4.2.5 Serial Clock (SCK)

The *Serial Clock* (SCK) synchronizes data transfer between the master and the FingerTIP™. Before the sensor can be selected, the *Serial Clock* (SCK) must be low for a minimum of t_{LCS} (see **table 7**). Otherwise the sensor will not be selected.

4.3 SPI Protocol and Timing

The following **figures 11a** and **11b** show the SPI protocol and timing for sending a command and receiving the response. The timing parameters are shown in **table 7**.

The FingerTIP™ must be selected, otherwise no commands will be accepted. To select the sensor, first set SCK to low and than set *Chip Select* (/CS, low active) to low.

With the rising edge of the SCK, the sensor reads in the command data on the *Serial Input* (SI). The command data format is 8-bit, starting with the LSB. With the 8th clock cycle, the MSB of the command data will be read in and the first bit (LSB) of the response will be output with the falling edge. Every new clock cycle outputs a new bit of the response (8 bits long) with the falling edge of SCK. If the MSB is output, SO is set to low. After /CS is set to high, *Serial Output* (SO) is set to tristate. Between a command and its response it is not allowed to deselect the sensor. Deselecting the FingerTIP™ interrupts the command/response sequence.

Before a new command can be sent by the master, the sensor must be deselected and then selected again.

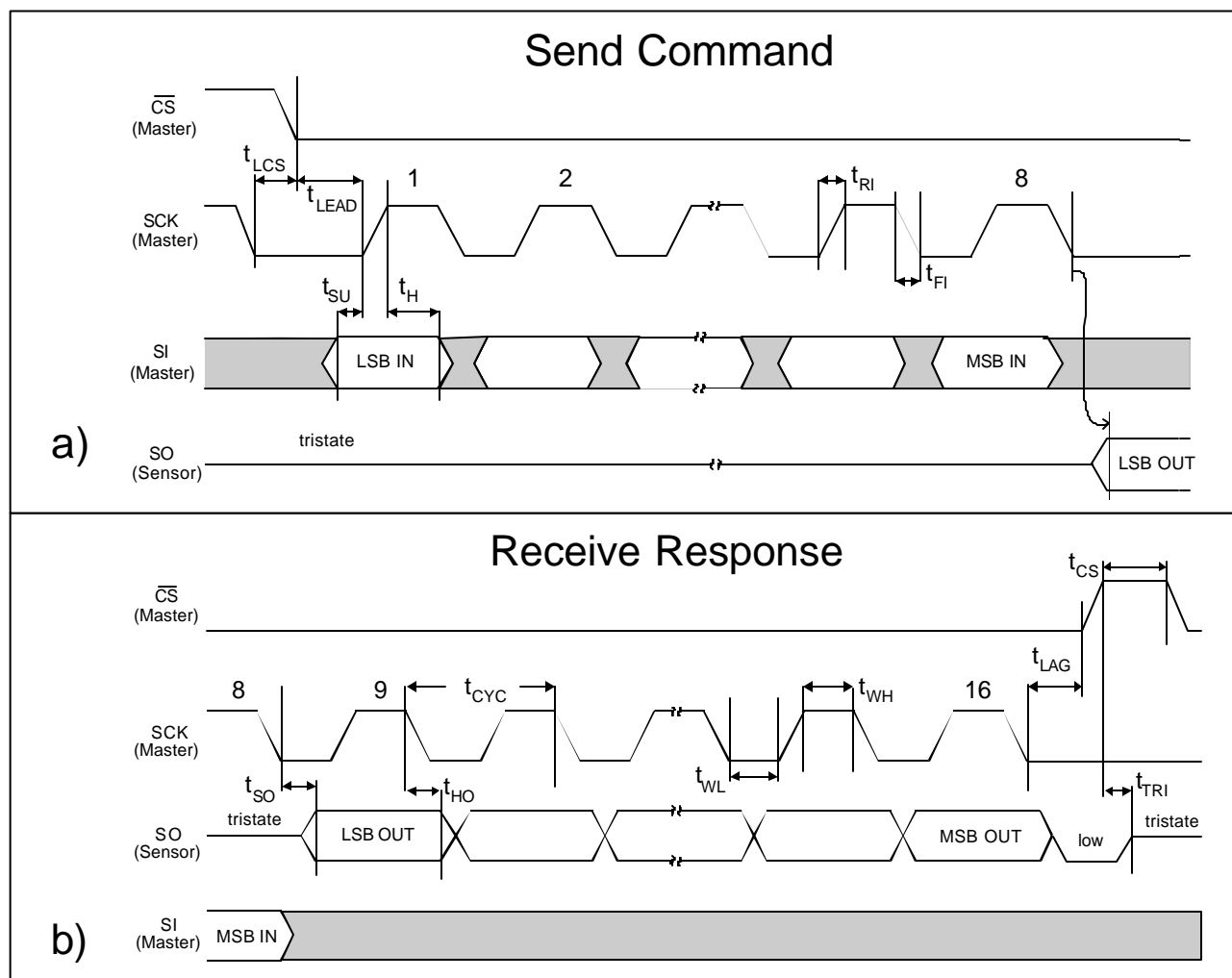

Figure 11: SPI Protocol and Timing: (a) Send a Command (b) Receive the Response

Interrupt of the Data Transfer

To interrupt the data transfer (sending or receiving data) the sensor must be deselected by setting /CS to high (SCK must be low before setting /CS to high). This can be done at any time. In this case, the sensor status could be undefined. Therefore the dynamics and pixel pointer must be set again. After the sensor is selected again, a new command can be sent.

Symbol	Parameter	Min.	Max.	Units
f_{SCK}	Clock Frequency ($V_{CC} = 4.5V - 5.5V$)		5	MHz
f_{SCK}	Clock Frequency ($V_{CC} = 3.3V - 4.5V$)		4	MHz
t_{LCS}	SCK before /CS	50		ns
t_{CYC}	Cycle Time $V_{CC} = 4.5V - 5.5V$	200		ns
t_{LEAD}	/CS Lead Time	100		ns
t_{LAG}	/CS Lag Time	100		ns
t_{WH}	Clock HIGH Time	80		ns
t_{WL}	Clock LOW Time	80		ns
t_{SU}	Data Setup Time	20		ns
t_H	Data Hold Time	20		ns
t_{RI}	Data In Rise Time	5	200	ns
t_{FI}	Data In Fall Time	5	200	ns
t_{CS}	/CS Deselect Time	100		ns
t_{TRI}	Change to Tristate Time		100	ns
t_{SO}	Output Setup Time		70	ns
t_{HO}	Output Hold Time	0		ns
t_{RO}^*	Output Rise Time		20	ns
t_{FO}^*	Output Fall Time		20	ns
	Power-On Reset Time		80	μs

* $C_{VO_Line} = 50 \text{ pF}$

Table 7: Timing Figures for the SPI '3-line bus' Protocol

4.4 The FingerTIP™ SPI Commands

In SPI mode the FingerTIP™ accepts four commands (**table 8**). These commands are used to read out the sensor status, reset the sensor, set the sensor to sleep mode, change the dynamics and read out the image data. Each command sent to the sensor will be answered by a response indicating the status of the sensor (**table 9**). A detailed description of commands and responses is given in the next sections.

COMMAND		
Name	Coding	Function
Set Mode	11XAXXXX LSB MSB	Set the FingerTIP™ to sleep mode Bit 4 (A) sets the dynamics: A = '0' low dynamics A = '1' high dynamics
Reset Pointer	10XXXXXX LSB MSB	Reset the pixel pointer to (1,1) Set the sensor into readout mode
Read Status	00XXXXXX LSB MSB	Read sensor status Set the sensor into readout mode
Read Data	01XXXXXX LSB MSB	Data read-out of the sensor array Set the sensor into readout mode

Table 8: SPI Commands (LSB first), X: Reserved for Future Use

RESPONSE (Status Byte)	
Bit No.	Function
0 (LSB)	Repetition of the last received FingerTIP™ SPI command
1	
2	0: Image data not valid
	1: Image data valid
3	0: Low dynamics selected
	1: High dynamics selected
4, 5, 6, 7 (MSB)	Reserved for internal use

Table 9: Contents of the Response (Status Byte)

4.4.1 Command: Set Mode

The *Set Mode* command sets the dynamics of the sensor, depending on bit 3 of the command word. Once this command has been sent and the complete response received, sleep mode is automatically activated for power saving. As every other command deselects sleep mode, there is no extra command for deselecting this mode.

The response echoes the command bits 0 and 1 and returns control information on the selected dynamics and on whether the image data is valid (**table 9**).

As opposed to EPP mode, the dynamics can be switched from high to low and vice versa at any time by using the *Set Mode* command.

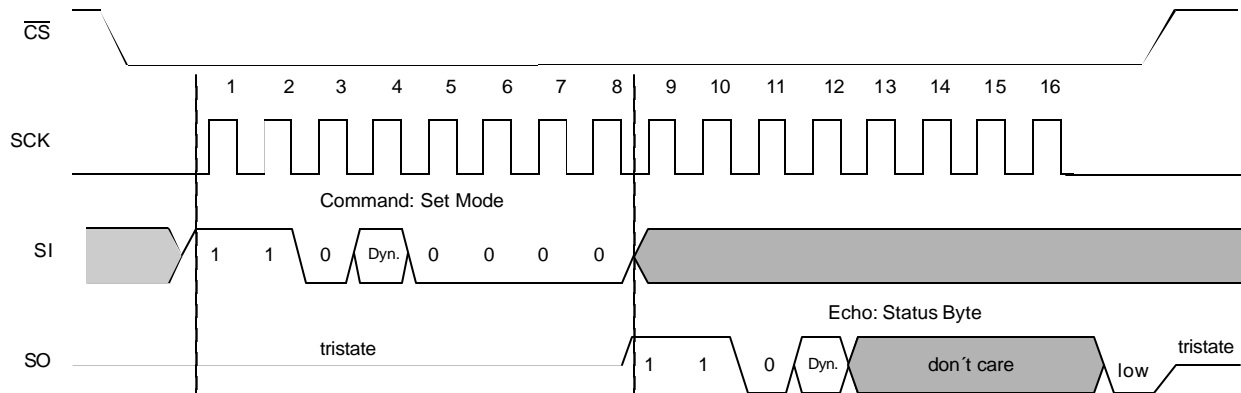

Figure 12: SPI Command *Set Mode* and its Response

4.4.2 Command: Reset Pointer

The *Reset Pointer* command sets the pixel pointer to position (1,1). Before a new image can be read, this command must be sent.

The response echoes the command bits 0 and 1 and returns control information on the selected dynamics and on whether the image data is valid (**table 9**).

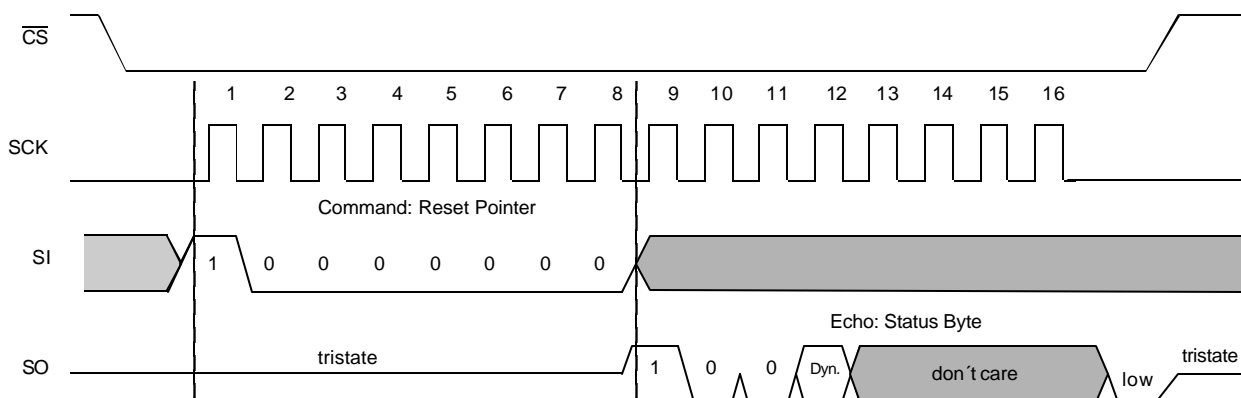

Figure 13: SPI Command *Reset Pointer* and its Response

4.4.3 Command: Read Status

The *Read Status* command forces the sensor to send the status byte. This command is helpful for analyzing the sensor status without changing the internal sensor state. Usually, this command is sent after the *Reset Pointer* command until the *image data valid bit* changes from '0' to '1'. Then the readout of the image can be started. In addition, the current dynamics mode is shown (**table 9**).

The response echoes the command bits 0 and 1 and returns control information on the selected dynamics and on whether the image data is valid (**table 9**).

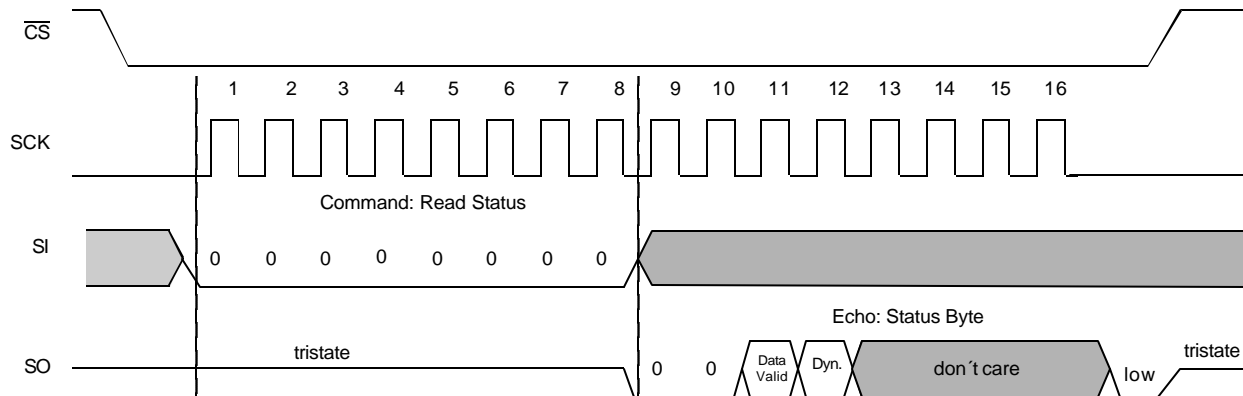

Figure 14: SPI Command *Read Status*

4.4.4 Command: Read Data

This command starts the readout of the image data. This command can only be sent if the image data valid bit is '1' (checked with the Read Status command). Once the sensor sends its response, the image data are continuously output, controlled by SCK. The image output data has an 8-bit format, starting with the LSB.

The response echoes the command bits 0 and 1 and returns control information on the selected dynamics and on whether the image data is valid (**table 9**).

A low-to-high transition on the /CS line is sufficient to interrupt the data transfer.

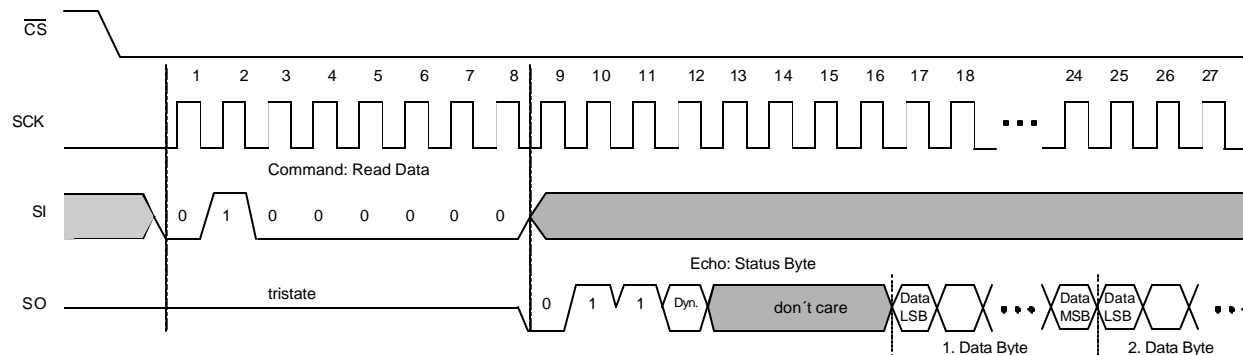

Figure 15: SPI Command *Read Data*

4.5 Fingerprint Image Readout

The following **figure 16** shows the block diagram for readout of the sensor in SPI mode.

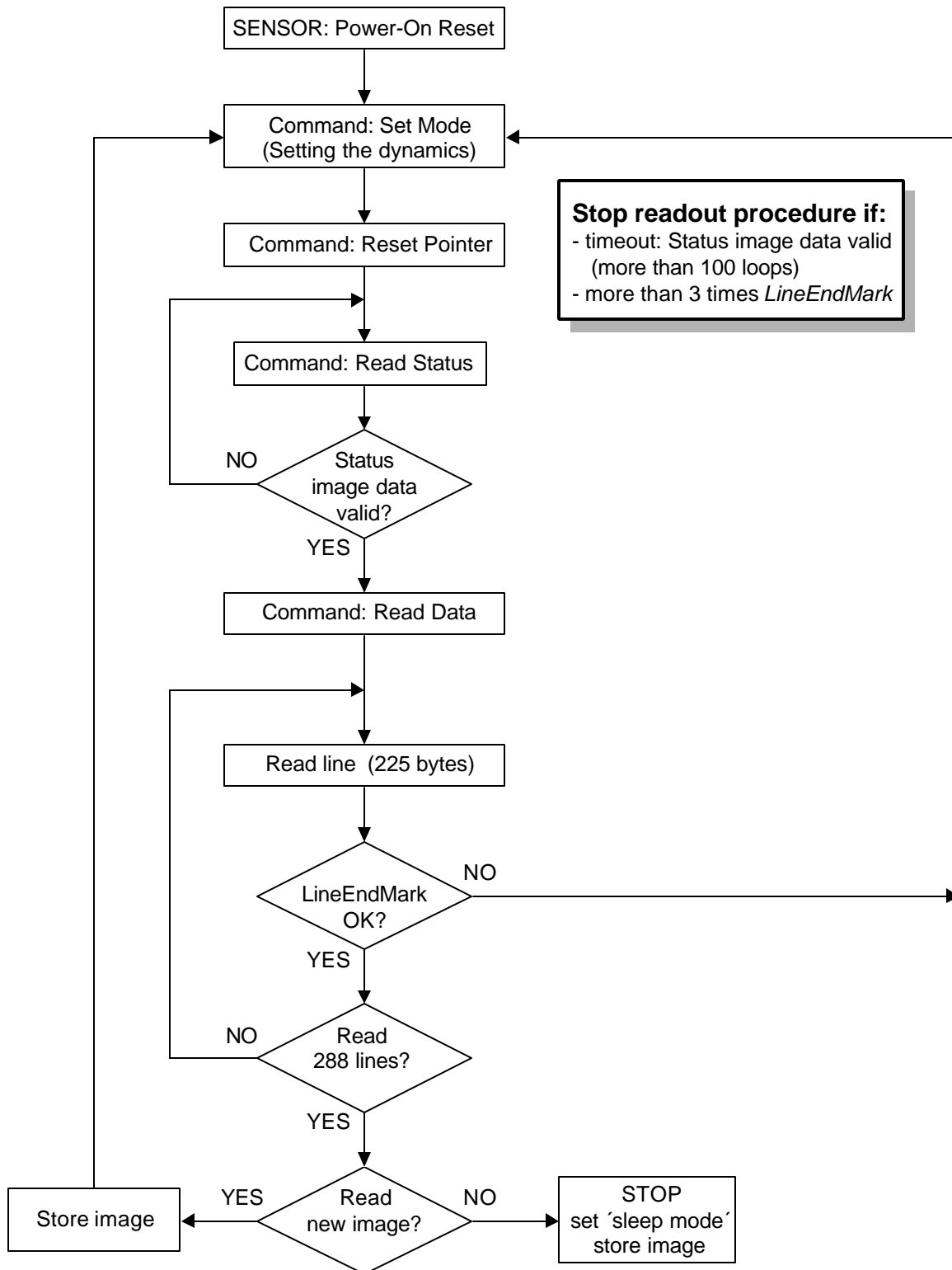

Figure 16: Block Diagram for Readout of the Image in SPI Mode

Once the sensor has completed its power-on reset (see **table 7**), first the dynamics must be set with the *Set Mode* command. The *Set Mode* command must be sent before every image readout. Next, the pixel pointer must be reset to position (1,1) with the *Reset Pointer* command. Then the status byte is read out until the image data is. This is done with the *Read Status* command. A timeout condition should be used for this test loop. It is recommended to stop after 100 loops.

Now the image data can be read out. The *Read Data* command starts the readout. After sending the *Read Data* command, the first byte output by the sensor is the command response. The next bytes are the image data. 225 SPI byte read cycles are needed for reading a complete line. The 225th byte of each line is the *LineEndMark* and must be 00h. Sometimes, interference such as ESD air discharge and alike can force double clocking on the sensor and the *LineEndMark* may not be 00h. Usually this kind of interference is singular and temporary. Therefore it is recommended to start reading a new image. After 64800 (225 x 288) SPI byte read cycles the whole image is read out.

If more than three readouts have failed because of *LineEndMark* error, the read out should be stopped in order to analyze the error. For more information and error handling please see the *Design-In Guideline /2/*.

Once the image readout is finished and the sensor is not needed for the moment, the sensor should be set to *sleep mode*.

4.6 Pinout of the FingerTIP™ in SPI Mode

In **figure 17**, the pinout of the FingerTIP™ module is shown. **Table 12** shows the pin names and the pin direction, including a short description.

Some of the pins are multi-function pins, depending on the selected interface mode – EPP or SPI. Chapter 5 gives a complete overview of the pins for EPP and SPI mode. The pad characteristics are also shown in chapter 5.

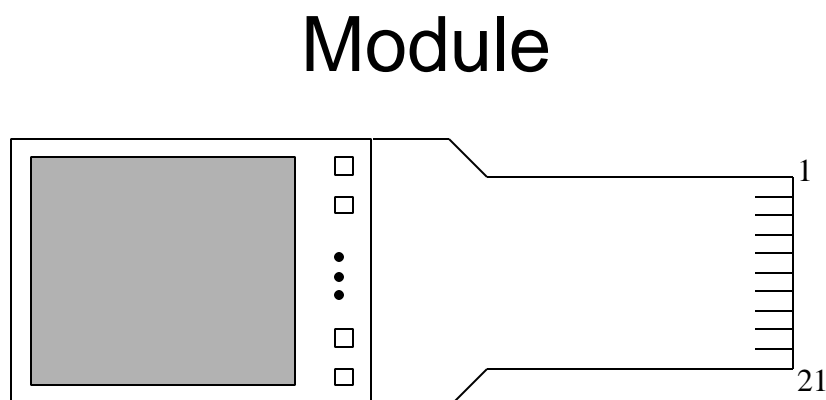

Figure 17: Pinout of the FingerTIP™ Sensor Module

Pad	Signal Direction	Signal Name	Active	Description
1		Prot. GND		Protective Ground
2		V _{SS}		Signal Ground
3	Input	EPP/SPI		Select Interface Mode: V _{CC} * : EPP 1.9; V _{SS} : SPI
4		Not used in SPI		Tristate in SPI mode, do not connect
5		Not used in SPI		Tristate in SPI mode, do not connect
6		Not used in SPI		Tristate in SPI mode, do not connect
7		Not used		Do not connect
8		Not used		Do not connect
9	Input	SI		Serial Input
10	Input	SCK		Clock
11	Input	/CS	low	Chip Select (low active)
12	Output	SO		Serial Output (tristate if not active)
13		Not used in SPI		Tristate in SPI mode, do not connect
14		Not used in SPI		Tristate in SPI mode, do not connect
15		Not used in SPI		Tristate in SPI mode, do not connect
16		Not used in SPI		Tristate in SPI mode, do not connect
17		Not used		Do not connect
18		Not used		Do not connect
19		V _{SS}		Signal Ground
20		V _{CC}		Supply voltage
21		Prot. GND		Protective Ground

* using a 22K pull-up resistor

Table 12: Module Pin Description for SPI Mode

4.7 Recommended Electrical Connection of the FingerTIP™ in SPI Mode

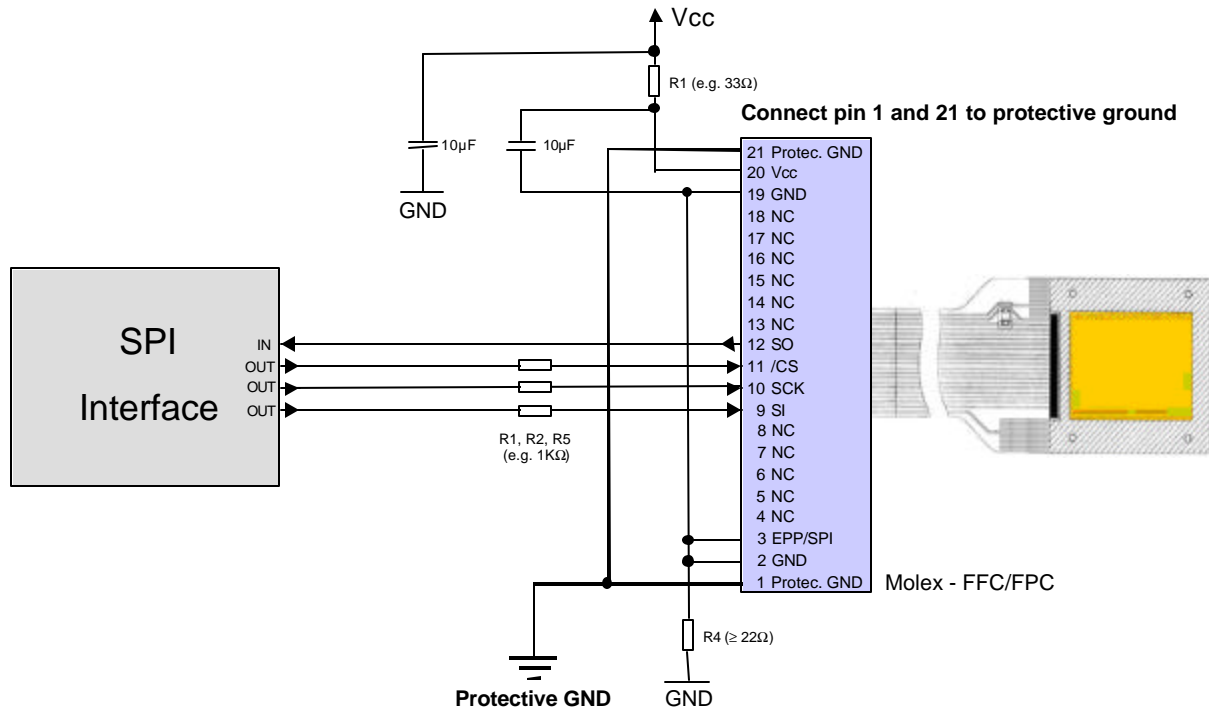

Figure 18: Typically circuit for Interfacing the FingerTIP™ to an SPI Interface

The serial resistors in the micro-controller output lines are used for current limitation and should be placed close to the sensor. The value of these resistors is dependent on the maximum output current, and supply voltage of the micro-controller. It is recommended to select values of the resistors such that the maximum current flowing into the sensor via the I/O lines is less than 15mA.

The resistors in the V_{CC} and GND line are also required for limiting the maximum supply current to the sensor and ESD protection. The nominal voltage shift induced on the sensor output signals is typically not an issue, but if required, a line driver can be employed for shifting the signals back to TTL levels.

If using additional SPI devices on the same SPI bus it must be guaranteed that the maximum current supplying the sensor via the I/O pins is limited to 15mA. Buffers can achieve decoupling of the FingerTIP from other SPI devices. If using a cable between the sensor and a micro-controller it must be shielded and have a maximum length of 1.5meters. The sensor side of the cable shield must be connected with a dedicated line directly to pins 1 and 21 of the sensor connector. Never connect signal ground with protective ground at sensor side of the cable. At the micro-controller side of the cable, the shield must be connected to protective ground. It is critical to isolate the sensor protective ground from the device power ground for optimum ESD performance.

5 Electrical Characteristics and Pin Description

This chapter summarizes the electrical characteristics, pad characteristics and gives a pin description.

5.1 FingerTIP™ Electrical Characteristics

The following **table 13** shows the electrical FingerTIP™ characteristics. Items such as supply voltage and current are listed separately for EPP 1.9 and SPI mode. All other chip features (e.g. output driver capacitance or ESD) are independent of the interface mode.

Parameter	Symbol	Limit value			Unit	Conditions
		Min.	Typ.	Max.		
Supply voltage	V_{CC}	4.5	5.0	5.5	V	EPP
	V_{CC}	3.3	5.0	5.5	V	SPI
Supply current (readout mode)	I_{CC}		10	12	mA	EPP 1 MHz, $V_{CC} = 5\text{ V}$, 25°C
	I_{CC}		10	12	mA	SPI 5 MHz, $V_{CC} = 5\text{ V}$, 25°C
Sleep mode current	I_{CCS}			1	mA	EPP / SPI, $V_{CC} = 5\text{ V}$, 25°C
ESD						
Air discharge		12			kV	ISO/EN 61000-4-2
Pads		2			kV	ANSI EOS/ESD S5.1-1993 (HBM)
Output driver and line capacitance	C_{I/O_Line}			50	pF	
Operating temperature	T_A	- 40	25	+ 85	$^\circ\text{C}$	
Storage temperature	T_S	- 40	25	+ 125	$^\circ\text{C}$	

Table 13: General FingerTIP™ Electrical Characteristics

5.2 Static Pad Characteristics

The following **table 14** shows the static characteristics of the FingerTIP™. Because of the limited number of pads the EPP and SPI mode use the same pads, so that the pad characteristics are the same.

Symbol	Parameter	Test condition	Min.	Typ.	Max.	Unit
V_{CC}	Supply voltage EPP mode		4.5	5.0	5.5	V
V_{CC}	Supply voltage SPI mode		3.3	5.0	5.5	V
V_{IL}	Input low level	$V_{CC} = 5V$	-0.5		0.8	V
	Low level input ¹ leakage current	$V_{IL} = +0.8V$ $V_{CC} = 5V$			20	μA
V_{IH}	Input high level	$V_{CC} = 5V$	2.0			V
	High level input ¹ leakage current	$V_{IH} = +2.0V$ $V_{CC} = 5V$			20	μA
	Peak input voltage transients		-2.0		7.0	V
V_{OL}	Output low level	$I_{OL} = 10\text{ mA}$; $V_{CC} = 5V$	-0.5		0.4	V
V_{OH}	Output high level	$I_{OH} = 10\text{ mA}$; $V_{CC} = 5V$	2.4			V
I_{OL}^2	Output current low	$V_{OL} = 0.8V$; $V_{CC} = 5V$	10			mA
I_{OH}^2	Output current high	$V_{OH} = 2.4V$; $V_{CC} = 5V$	10			mA
$C_{I/O}$	Pad capacitance (including flexible PCB)				15	pF

¹ The EPP/SPI input has an internal pull up resistor. Therefore the input leakage current is higher for this pad.

² The pads are designed for low power consumption. Therefore the output current is limited to values lower than those specified in the EPP 1.9 specification.

Table 14: Static Characteristics

5.3 Pin Description

The following **table 15** shows the pin description of the FingerTIP™.

Pad No.	I / O	Signal Name	Active	Description
1		Prot. GND		Protective Ground
2		V _{SS}		Signal Ground
3	Input	EPP/SPI		Select Interface Mode: V _{CC} * : EPP 1.9; V _{SS} : SPI
4	Input	/RESET	Low	EPP: Set pixel pointer to position (1,1) and change the dynamics SPI: No function (tristate)
5	Input	/REQUEST	Low	EPP: Start readout of a byte SPI: No function (tristate)
6	Output	READY	High	EPP: Indicates valid data on DA0 to DA7 (tristate in sleep mode) SPI: No function (tristate)
7		Not used		Do not connect
8		Not used		Do not connect
9	EPP: Output SPI: Input	DA0/SI		EPP: Data line DA0 (tristate) SPI: Serial In (SI)
10	EPP: Output SPI: Input	DA1/SCK		EPP: Data line DA1 (tristate) SPI: Serial Clock (SCK)
11	EPP: Output SPI: Input	DA2/CS		EPP: Data line DA2 (tristate) SPI: Chip Select (CS)
12	EPP: Output SPI: Output	DA3/SO		EPP: Data line DA3 (tristate) SPI: Serial Out (SO)
13	Output	DA4		EPP: Data line DA4 (tristate) SPI: No function (tristate)
14	Output	DA5		EPP: Data line DA5 (tristate) SPI: No function (tristate)
15	Output	DA6		EPP: Data line DA6 (tristate) SPI: No function (tristate)
16	Output	DA7		EPP: Data line DA7 (tristate) SPI: No function (tristate)
17		Not used		Do not connect
18		Not used		Do not connect
19		V _{SS}		Signal Ground
20		V _{CC}		Supply voltage
21		Prot. GND		Protective Ground

* using a 22K pull-up resistor

Table 15: Pin Description

6 Module

6.1 Module Dimensions and Material

The following **figure 18** shows schematic views and dimensions of the FingerTIP™ module. The material of the module is PPS with a copper metal frame. The PCB interconnect consists of PI. The materials meets flammability standard UL94V0.

The 21 pin connector with 0.5 mm pitch is available from Molex, part name 52435-2191 (FPC connector), or from JST, part name 21FLZ-SM1-TB.

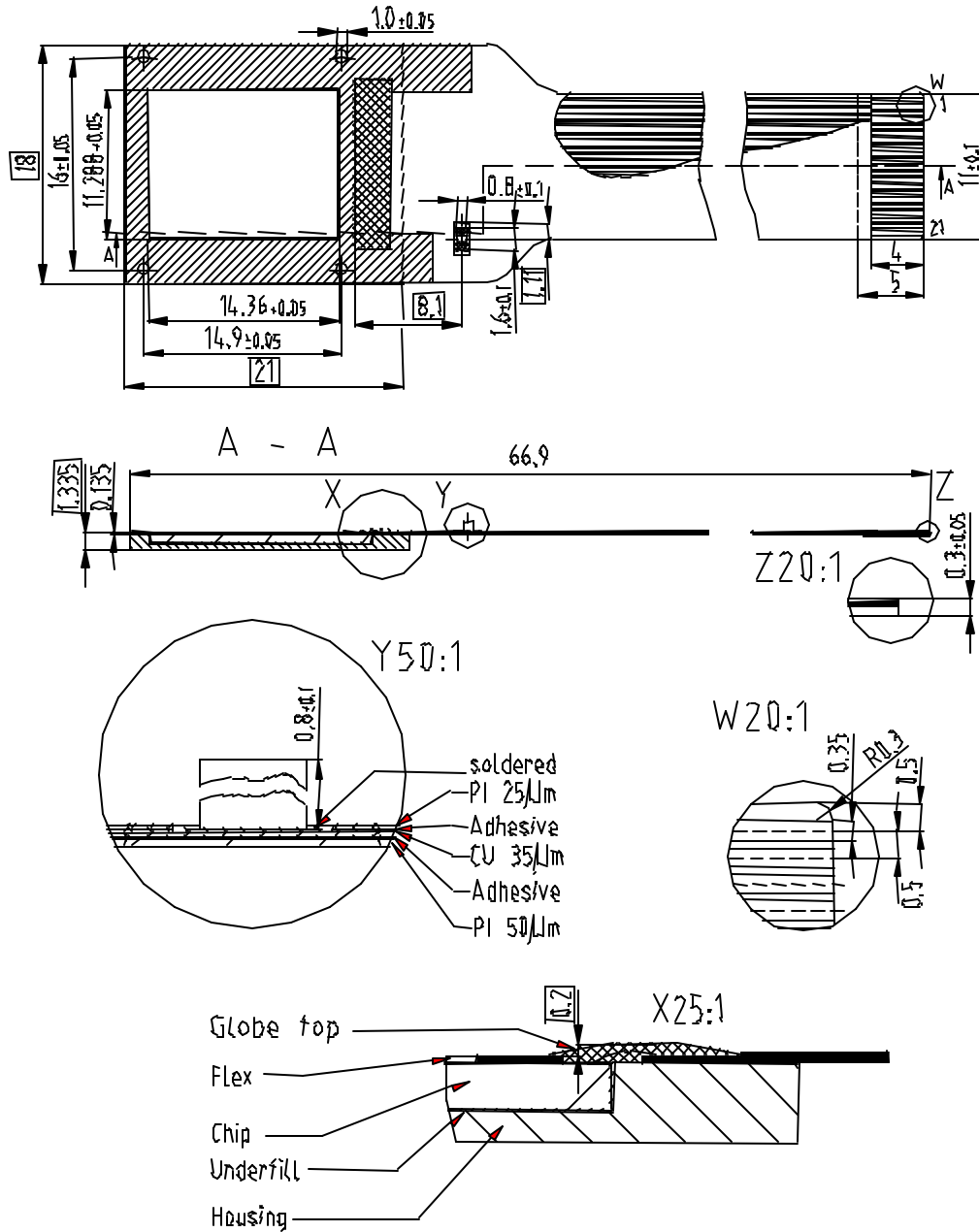

Figure 18: Module Dimensions, Top and Side View

7 FingerTIP™ SDK Software and Biometric Algorithms

This chapter is intended to give users a brief overview (see **figure 19**) of the biometric algorithms delivered optionally with the FingerTIP™. These algorithms are part of the FingerTIP™ SDK software package. Though the flow chart is simplified, it shows the principles of the underlying signal processing performed on a processor engine. The major software blocks of the biometric algorithms are the Encoder and the Matcher module.

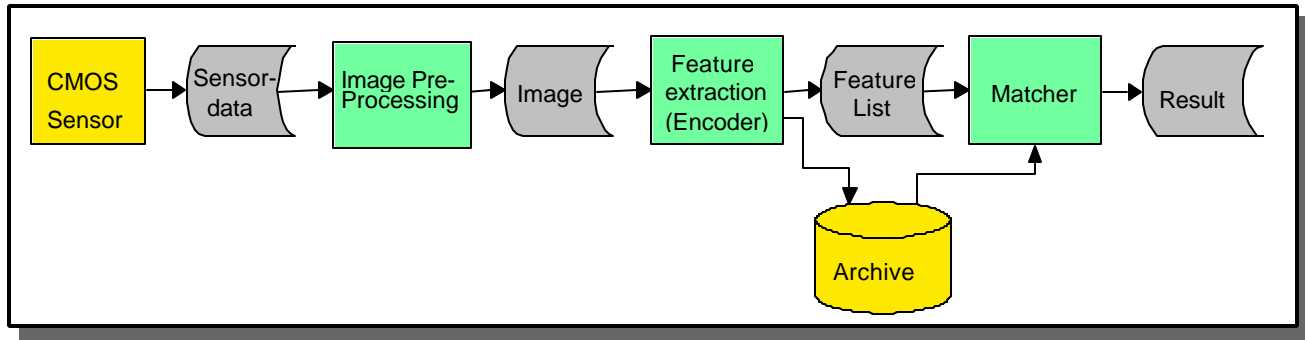

Figure 19: Principle Software Data Flow

7.1 Enrollment

Enrollment is the process of generating the reference data set of a fingerprint. This data set is used as the reference pattern which has to be matched for identification or verification.

7.2 Verification

Verification refers to the process of comparing a fingerprint which has just been transferred from the FingerTIP™ to the background processing engine with a set of reference data. As a prerequisite the claimed user's identity must be known to the system. The system verifies this identity by comparing the current fingerprint with the fingerprint of the reference image.

For detailed information on the software structure and its functionality refer to the Infineon documentation: *FingerTIP™ Software Package User's Guide /4/* and *FingerTIP™ Software Package Programmer's Guide /5/*.

At the moment there is no exclusive international application programming interface standard (API) for biometric applications. Actually several standards are being developed right now, and the unification process is underway. Thus the FingerTIP™ algorithms come as the easy to use SDK, that has been created – where reasonable - in most compliance with the respective versions of BAPI and HA-API standards. Infineon is a BioAPI member and, once finished, the FingerTIP™ SDK will be compliant with the BioAPI standard.

8 Literature

/1/ Mechanical Design in Guide of the FingerTIP™

/2/ Electrical Design in Guide of the FingerTIP™

/3/ Parallel Port Complete by Jan Alexson, published by Lakeview Research 1997

/4/ *FingerTIP™ Software Package User's Guide*

/5/ *FingerTIP™ Software Package Programmer's Guide.*

9 Index

- air line 8, 9
- biometric algorithms 36
- capacitive measurement technique 7, 8
- capture time 6
- characteristics 32
- chip select 21
- column 10
- connector 34
- defect rate 11
- dimensions 35
- dynamics 9, 15
- electrical characteristics 32
- EPP 1.9 11, 12
- EPP pin description 18
- EPP pin names 13
- EPP protocol 14
- EPP readout 16
- EPP timing 14
- error handling 17, 29
- features 6
- finger ridges 9
- finger valleys 9
- fingerprint readout 10
- flexible PCB 6
- functional block diagram 7
- gray level 7, 8
- histogram 8
- IEEE 1284 standard 12
- lifetime 6
- line 10
- LineEndMark 10, 17, 29
- module 6, 35
- pad characteristics 33
- parallel interface 12
- pin description 31
- pinout: module / chip 17, 30
- pixel pointer 10, 15
- power on reset 11
- power saving mode 11, 26
- printer port 13
- read data 27
- read status 27
- reference voltage 7, 9
- reset pointer 25, 26
- resolution 6
- response 23
- SDK software package 36
- sensor surface 7
- serial clock 22
- serial input 21
- serial interface 20
- serial output 22
- set mode 26
- sleep mode 11, 15, 26
- SPI 11, 20
- SPI commands 25
- SPI mode 21
- SPI pin description 30
- SPI pin names 21
- SPI protocol 23
- SPI readout 28
- SPI timing 21, 26
- status byte 27
- water line 8, 9