

DESCRIPTION

The EV2607DL-00A is an evaluation board for the MP2607, a linear, high-performance single cell Li-Ion battery charger integrated system power path management. It takes power input from either AC adapter or USB port to power the system and charge the battery independently.

The charger section features trickle charge, constant current (CC) and constant voltage (CV) charging modes with programmable charge current, charging termination and charge status.

The system power path management function ensures continuous supply to the system. It features a low drop-out regulator from input to system and a switch from battery to system. If the input is valid, the power path management separates charging function and powering system load. If the input is removed, the system load will be powered by battery.

ELECTRICAL SPECIFICATION

Parameter	Symbol	Value	Units
Input Voltage	V_{IN}	4.5 to 5.9	V
Charge Current	I_{CHG}	650	mA

FEATURES

- 12V maximum Voltage for the input source
- Selectable Input Power Sources from AC Adapter or USB Port
- Programmable Charge Current
- Built-in current limit for USB port
- Complete Power Path Management for Simultaneously Powering the System and Charging the Battery.
- 0.75% V_{BATT} Accuracy
- Thermal Protection
- Fault and Charge Status Indicator
- Built-in Timer for Charge Termination

APPLICATIONS

- Smart Handheld Devices
- Cell Phones, PDAs, MP3 Players
- Digital Cameras, GPS
- Handheld Test Equipment

"MPS" and "The Future of Analog IC Technology" are Registered Trademarks of Monolithic Power Systems, Inc.

EV2607DL-00A EVALUATION BOARD



(L x W x H) 2.0" x 1.9" x 0.5"
(5.0cm x 4.8cm x 1.2cm)

Board Number	MPS IC Number
EV2607DL-00A	MP2607DL

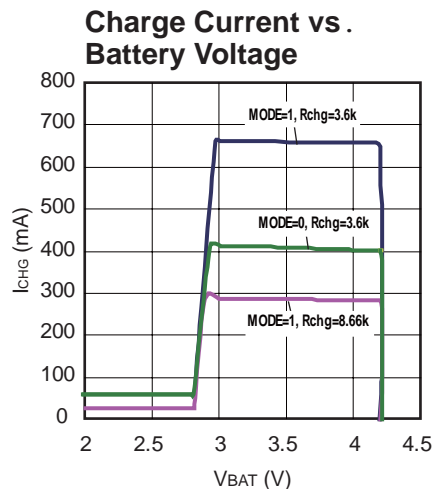

EVALUATION BOARD SCHEMATIC

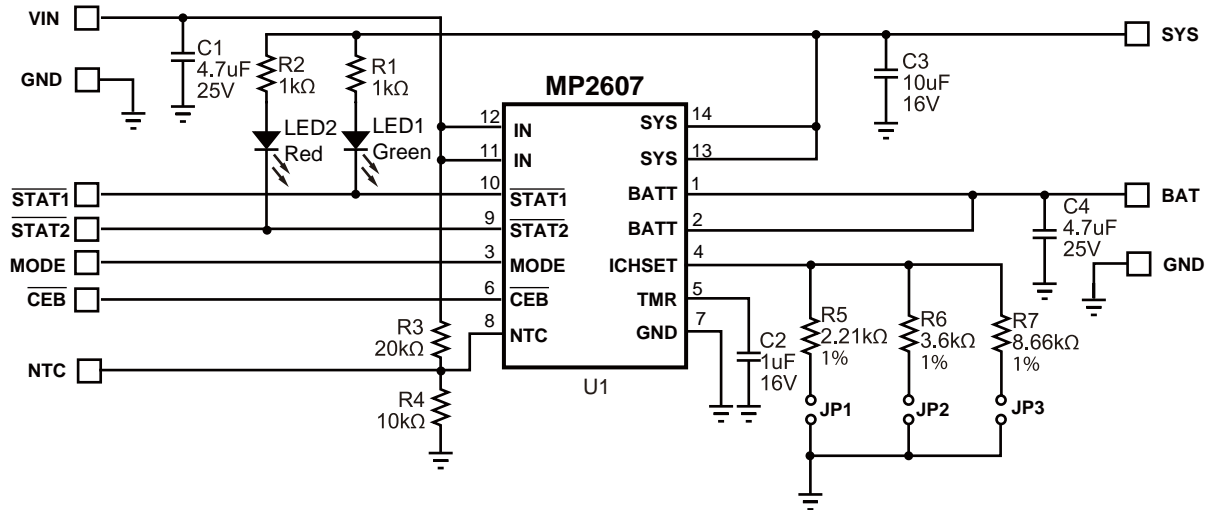

EV2607DL-00A BILL OF MATERIALS

Qty	Ref	Value	Description	Package	Manufacturer	Manufacturer P/N
2	C1, C4	4.7uF	Ceramic Cap, 25V, X7R	1206	Murata	GRM31DR71E475K
1	C2	1uF	Ceramic Cap, 16V, X7R	0805	Murata	GRM21BR71C105K
1	C3	10uF	Ceramic Cap, 16V, X7R	1210	Murata	GRM32DR71C106K
3	JP1, JP2, JP3		2-Pin Connector Header, 0.100"		Molex	10-89-1601
1	LED1	Green	Led Green, Surface Mount	0805	Panasonic	LNJ306G5URA
1	LED2	Red	Led Red, Surface Mount	0805	Panasonic	LNJ206R5RRX
2	R1, R2	1K	Film Res, 5%	0603	Panasonic	ERJ-3GEYJ102V
1	R3	20k	Film Res, 1%	0603	Panasonic	ERJ-3EKF2002V
1	R4	10k	Film Res, 1%	0603	Panasonic	ERJ-3EKF1002V
1	R5	2.21K	Film Res, 1%	0603	Panasonic	ERJ-3EKF2211V
1	R6	3.6K	Film Res, 1%	0603	Panasonic	ERJ-3EKF3601V
1	R7	8.66K	Film Res, 1%	0603	Panasonic	ERJ-3EKF8661V
1	U1		Linear Charger	QFN14	MPS	MP2607DL

PRINTED CIRCUIT BOARD LAYOUT

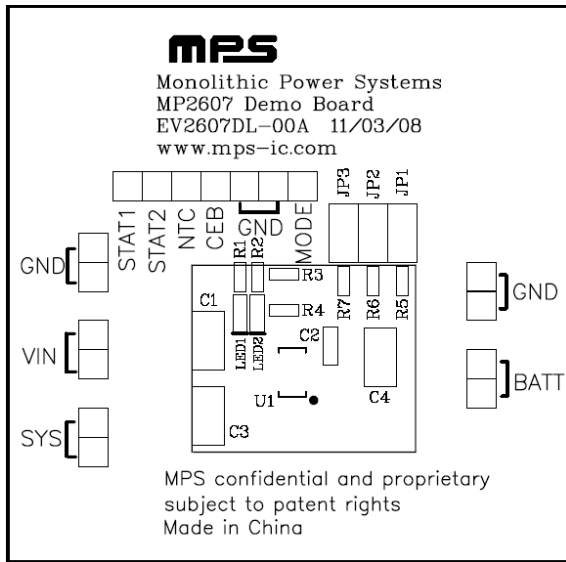

Figure 1—Top Silk Layer

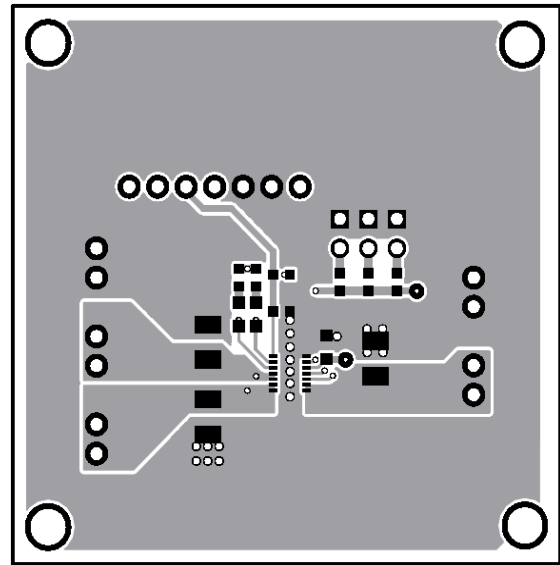

Figure 2—Top Layer

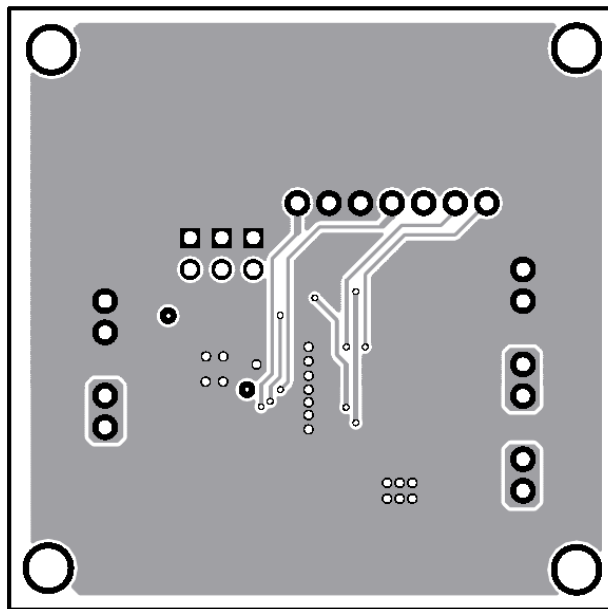

Figure 3—Bottom Layer

QUICK START GUIDE

The BATT output voltage on this board is preset to 4.2V (for a single cell battery). The SYS output voltage is regulated to 4.9V internally for AC Adapter Input. The board layout accommodates most commonly used capacitors.

The LEDs are fault and charge indicators. The states of LED1 and LED2 under different operation are as follow:

Charger Status	LED1	LED2
Charging	On	On
End of Charge	On	Off
Charge Suspended (due to battery supplement mode or NTC out of range)	Off	On
Fault/disable (due to timer-out, internal thermal shutdown)	Off	Off

Attach the input to the IN pin, Set the charge current I_{CHG} using the jumpers JP1, JP2 and JP3 per the following table:

JP1	JP2	JP3	I_{CHG}
X		X	1250mA
X			1000mA
	X	X	900mA
	X		650mA
		X	250mA

where “X” indicates a connection.

1. Attach the positive and negative ends of the load to the SYS and GND pins, respectively.
2. Attach the positive and negative ends of the battery to the BATT and GND pins, respectively.
3. Attach the input voltage ($V_{IN}=5V$) and the input ground to the VIN and GND pins, respectively.
4. Set V_{CEB} lower than 0.4V to enable the device and higher than 1.5V to disable it.
5. Set Mode=1 to choose AC adapter input and Vin supplies the current for the system and charging the battery.
6. Set Mode=0 to choose USB input, and the input current limit is set internally. Increase the system load up to 1A, during which period, the charge current decreased first, and then supply the system load (supplement mode).

NOTICE: The information in this document is subject to change without notice. Please contact MPS for current specifications. Users should warrant and guarantee that third party Intellectual Property rights are not infringed upon when integrating MPS products into any application. MPS will not assume any legal responsibility for any said applications.