



The Future of Analog IC Technology®

EV26058DQ-00A

28V, 1A Li + Linear Battery Charger With Trickle Charge Timer and LDO Mode EV Board

DESCRIPTION

The EV26058DQ-00A is an evaluation board for the MP26058, a linear, high-performance single cell Li-Ion battery charger.

By integrating high voltage input protection into the charger IC, the MP26058 can tolerate an input surge up to 28V.

The MP26058 features constant current (CC) and constant voltage (CV) charging modes with programmable charge currents (200mA to 1A), Time out control battery full terminated control, thermal protection, battery temperature monitoring, reverse current blocking and trickle charge. The device also provides AC adapter power good and charge status indications to the system.

ELECTRICAL SPECIFICATION

Parameter	Symbol	Value	Units
Input Voltage	V _{IN}	5	V
Charge Current	I _{CHG}	0.8	A

FEATURES

- Input Surge Up to 28V
- Input polarity reverse protection to - 16V
- Wide input operating range 2.8V – 7V
- Adapter or USB Input
- Programmable Charge Current: 100mA to 1A
- Programmable timer
- 7V Input Over Voltage Protection
- Battery Temperature Monitoring
- Automatic die temperature limiting
- Fault and Charge Status Indicators
- Soft-Start to limit inrush current
- Fully Assembled and Tested

APPLICATIONS

- Cell Phones
- Digital Cameras
- Smart Phones
- PDAs
- MP3 Players

"MPS" and "The Future of Analog IC Technology" are Registered Trademarks of Monolithic Power Systems, Inc.

EV26058DQ-00A EVALUATION BOARD



(L x W x H) 2.0" x 1.9" x 0.5"
(5.0cm x 4.8cm x 1.2cm)

Board Number	MPS IC Number
EV26058DQ-00A	MP26058DQ

EVALUATION BOARD SCHEMATIC

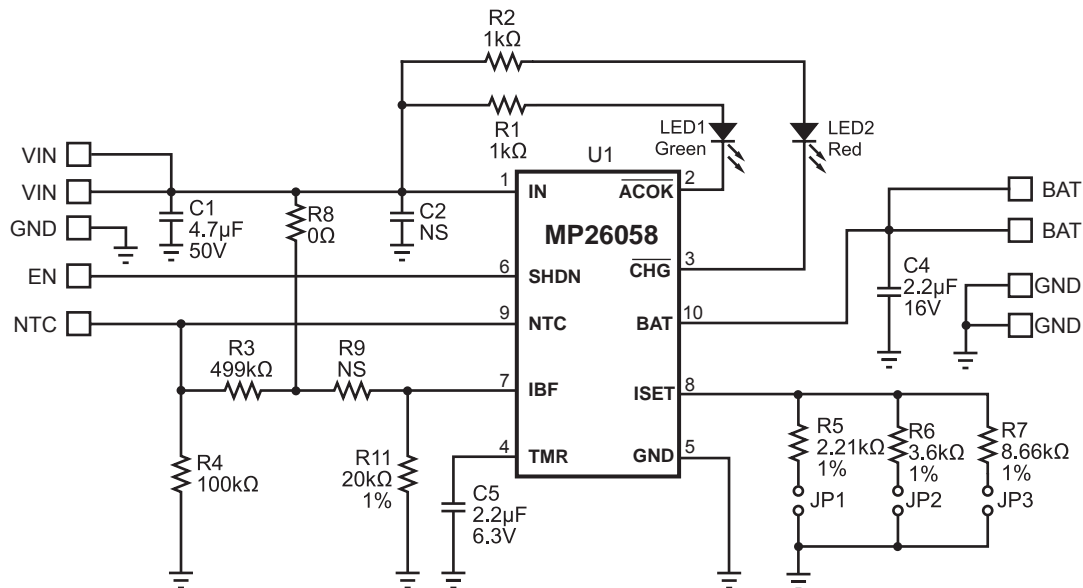

EV26058DQ-00A BILL OF MATERIALS

Qty	Ref	Value	Description	Package	Manufacturer	Manufacturer P/N
1	C1	4.7μF	Ceramic Cap., 50V, X7R	1210	Murata	GRM32ER71H475K
					Holystone	C1210B475M035T
1	C2	NS	Not Stuffed	1206		
1	C4	2.2μF	Ceramic Cap., 16V, X7R	1210	Murata	GRM32MR71C225MC01L
1	C5	2.2μF	Ceramic Cap., 6.3V, X7R	0805	Murata	GRM219C70J225K
3	JP1, JP2, JP3		3x2-Pin Connector Header, 0.100"		Molex	10-89-1601
1	LED1		Led Green, Surface Mount	0805	Panasonic	LNJ306G5URA
1	LED2		Led Red, Surface Mount	0805	Panasonic	LNJ206R5RRX
2	R1, R2	1kΩ	Film Res., 5%	0603	Panasonic	ERJ-3GEYJ102V
1	R3	499kΩ	Film Res., 1%	0603	Panasonic	ERJ-3EKF4993V
1	R4	100kΩ	Film Res., 1%	0603	Panasonic	ERJ-3EKF1003V
1	R5	2.21kΩ	Film Res., 1%	0603	Panasonic	ERJ-3EKF2211V
1	R6	3.6kΩ	Film Res., 1%	0603	YAGEO	9C06031A3601FKHFT
1	R7	8.66kΩ	Film Res., 1%	0603	Panasonic	ERJ-3EKF8661V
1	R8	0Ω	Film Res., 5%	0603	YAGEO	9C06031A0000FKHFT
	R9	NS	Not Stuffed			
1	R11	20kΩ	Film Res., 1%	0603	Panasonic	ERJ-3EKF2002V
1	U1		Linear Charger	QFN10	MPS	MP26058DQ

Note:

(1) R11's position is as same as C3.

PRINTED CIRCUIT BOARD LAYOUT

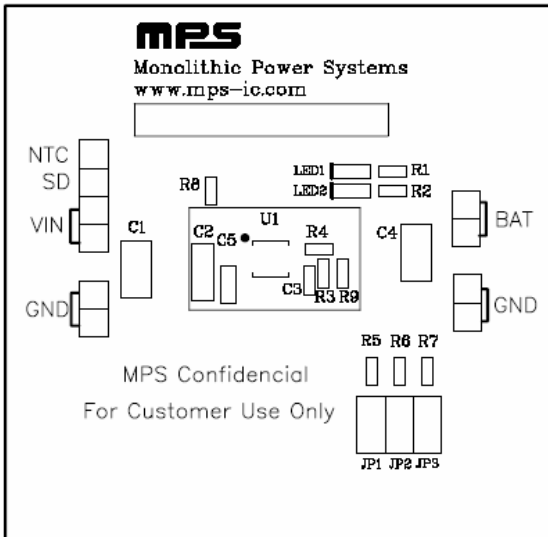

Figure 1—Top Silk Layer

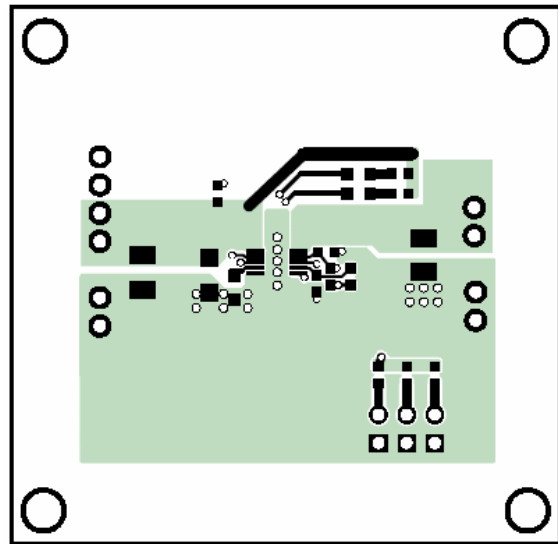

Figure 2—Top Layer

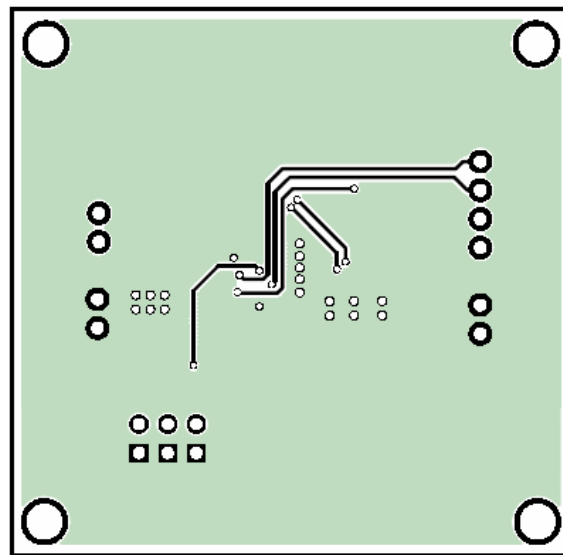

Figure 3—Bottom Layer

QUICK START GUIDE

The output voltage on this board is preset to 4.2V (for a single cell battery). The board layout accommodates most commonly used capacitors.

The LEDs are power indicators. When LED1 is on, the 5V input is present (LED1 is off when the input is disconnected). When LED2 is on, the battery is charging, and when the battery is full or there is no battery connected, LED 2 will turn off.

1. Set the charge current I_{CHG} using the jumpers JP1, JP2 and JP3 per the following table:

JP1	JP2	JP3	I_{CHG}
X		X	1000mA
X			800mA
	X	X	700mA
	X		500mA
		X	200mA

Where “X” indicates a connection.

2. Attach the positive and negative ends of the load to the VOUT and GND pins, respectively.
3. Attach the input voltage ($V_{IN}=5V$) and the input ground to the VIN and GND pins, respectively.
4. Set the Timer C5:

$$T(\text{min}) = 196 \times 10^{-6} \times C_5$$

5. Set the battery full threshold I_{BF} using R11:

$$I_{BF} = 1700/R11.$$

NOTICE: The information in this document is subject to change without notice. Please contact MPS for current specifications. Users should warrant and guarantee that third party Intellectual Property rights are not infringed upon when integrating MPS products into any application. MPS will not assume any legal responsibility for any said applications.