



The Future of Analog IC Technology®

MP6907

Fast Turn-off Flyback Synchronous Rectifier that Supports CCM, DCM and QR Operation Modes

DESCRIPTION

The MP6907 is a low-drop diode emulator controller IC that, when combined with an external MOSFET, can replace Schottky diodes in high-efficiency flyback converters. The MP6907 regulates the forward drop of an external switch to about 70mV, which switches off once the voltage becomes negative.

The MP6907 provides a SYNC interface to receive an external signal to shut down the gate driver for reliable continuous conduction mode (CCM) operation. A programmable light-load sleep mode can reduce the IC's quiescent current to ~150µA.

The MP6907 is available in compact SOIC8 and TSOT23-6 packages.

FEATURES

- Works with 12V Standard and 5V Logic Level MOSFETS
- Compatible with Energy Star 1W Standby Requirements
- Fast Turn-Off Total Delay of 25ns
- 4.2V~35V Wide VDD Operating Range
- ~150µA Quiescent Current in Light-Load Mode⁽¹⁾
- Supports CCM, DCM, and Quasi-Resonant Operation
- SYNC Interface for CCM Operation
- Supports High-Side and Low-Side Rectification
- Power Savings of up to 1.5W in a Typical Notebook Adapter
- Available in SOIC8 and TSOT23-6 Packages

APPLICATIONS

- Industrial Power Systems
- Distributed Power Systems
- Battery Powered Systems
- Flyback Converters

All MPS parts are lead-free, halogen-free, and adhere to the RoHS directive. For MPS green status, please visit the MPS website under Quality Assurance. "MPS" and "The Future of Analog IC Technology" are registered trademarks of Monolithic Power Systems, Inc.

NOTE:

1) Related issued patent: US Patent US8,067,973; US8,400,790. CN Patent ZL201010504140.4; ZL200910059751.X. Other patents pending.

TYPICAL APPLICATION

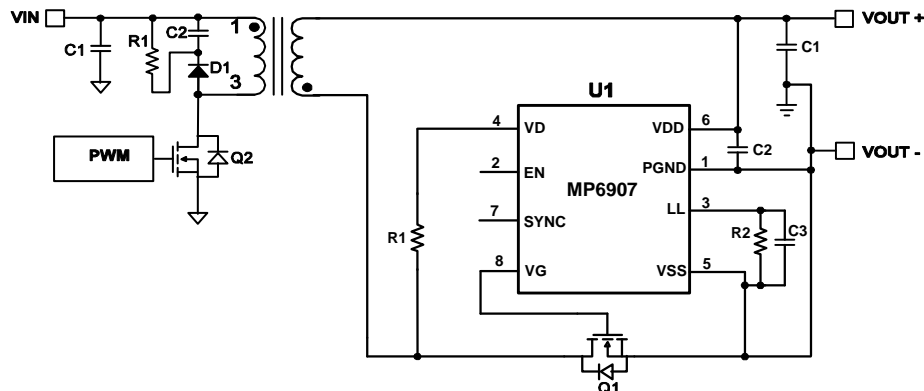

ORDERING INFORMATION

Part Number*	Package	Top Marking
MP6907GS	SOIC8	<i>See Below</i>
MP6907GJ	TSOT23-6	<i>See Below</i>

* For Tape & Reel, add suffix -Z (e.g. MP6907GS-Z)

* For Tape & Reel, add suffix -Z (e.g. MP6907GJ-Z)

TOP MARKING (MP6907GS)

MP6907
LLLLLLLLL
MPSYWW

MP6907: Part number
LLLLLLLLL: Lot number
MPS: MPS prefix
Y: Year code
WW: Week code

TOP MARKING (MP6907GJ)

|ATPY

ATP: Product code of MP6907GJ
Y: Year code

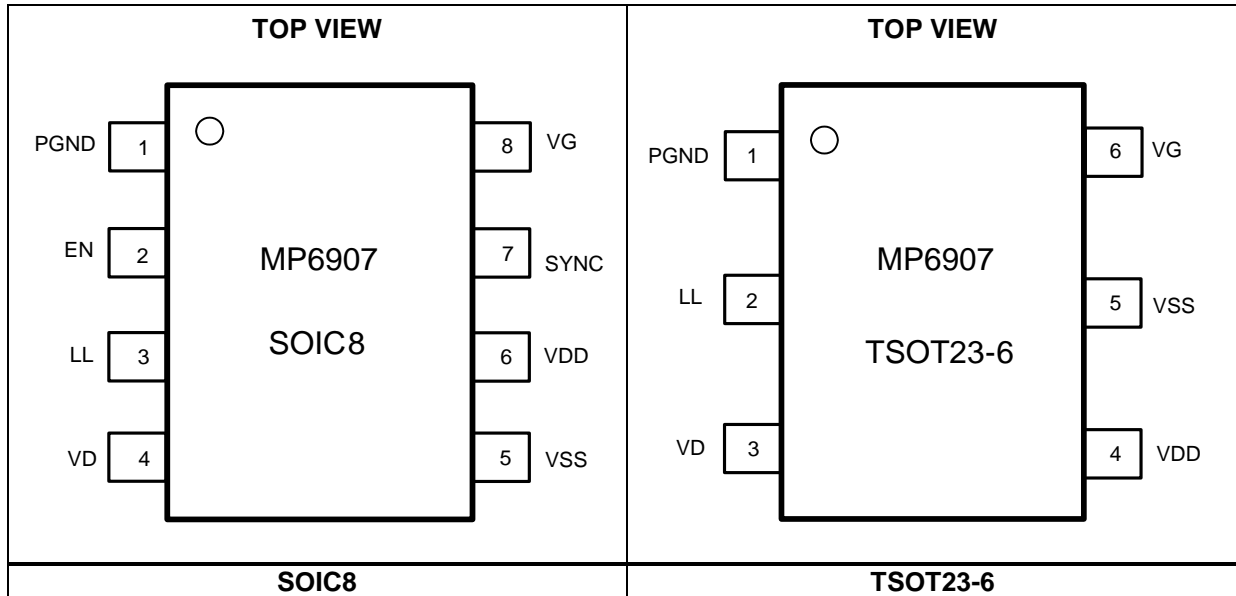
PACKAGE REFERENCE

ABSOLUTE MAXIMUM RATINGS ⁽¹⁾

VDD to VSS.....	-0.3V to +38V
PGND to VSS	-0.3V to +0.3V
VG to VSS	-0.3V to +20V
VD to VSS	-1V to +180V
SYNC, LL, EN to VSS.....	-0.3V to +6.5V
Continuous power dissipation (T _A = +25°C)	

(2)

SOIC8.....	1.4W
Junction temperature.....	150°C
Lead temperature (solder)	260°C
Storage temperature.....	-55°C to +150°C

Recommended Operation Conditions ⁽³⁾

VDD to VSS.....	4.2V to 35V
Maximum junction temp. (T _J).....	+125°C

Thermal Resistance ⁽⁴⁾ θ_{JA} θ_{JC}

SOIC8.....	90	45	°C/W
TSOT23-6.....	220	110	°C/W

NOTES:

- 1) Exceeding these ratings may damage the device.
- 2) The maximum allowable power dissipation is a function of the maximum junction temperature T_J(MAX), the junction-to-ambient thermal resistance θ_{JA}, and the ambient temperature T_A. The maximum allowable continuous power dissipation at any ambient temperature is calculated by P_D(MAX)=(T_J(MAX)-T_A)/θ_{JA}. Exceeding the maximum allowable power dissipation produces an excessive die temperature, causing the regulator to go into thermal shutdown. Internal thermal shutdown circuitry protects the device from permanent damage.
- 3) The device is not guaranteed to function outside of its operating conditions.
- 4) Measured on JESD51-7, 4-layer PCB.

ELECTRICAL CHARACTERISTICS

$V_{DD} = 12V$, $-40^{\circ}C \leq T_J \leq +125^{\circ}C$, unless otherwise noted.

Parameter	Symbol	Conditions	Min	Typ	Max	Units
VDD voltage range			4.2		35	V
VDD UVLO rising			3.7	3.97	4.2	V
VDD UVLO hysteresis			0.13	0.185	0.24	V
Operating current	I_{CC}	$C_{LOAD} = 4.7nF$, $F_{SW} = 100kHz$		8.5	10	mA
Quiescent current	I_Q	$V_{SS} - V_D = 0.5V$		2.5	3.2	mA
Shutdown current		$V_{DD} = 4V$, $EN = 0V$		105	150	μA
		$V_{DD} = 20V$, $EN = 0V$		120	200	
		$V_{DD} = 4V$, $LL = 0V$			400	
		$V_{DD} = 20V$, $LL = 0V$			450	
Light-load mode current				155	210	μA
Thermal shutdown ⁽⁵⁾				150		$^{\circ}C$
Thermal shutdown hysteresis ⁽⁵⁾				10		$^{\circ}C$
Enable UVLO rising	V_{EN-R}		1.4	1.74	2.1	V
Enable UVLO hysteresis			0.1	0.27	0.45	V
Internal pull-up current on EN				12	21	μA
Control Circuitry Section						
VSS - VD forward voltage	V_{fwd}		48	65	82	mV
Turn-off threshold (VSS - VD)			5	15	28	mV
Turn-on delay	T_{Don}	$C_{LOAD} = 4.7nF$, $V_{GS} = 2V$		60	105	ns
	T_{Don}	$C_{LOAD} = 10nF$, $V_{GS} = 2V$		85	150	ns
Input bias current on VD		$V_D = 180V$			1	μA
Turn-on blanking time	T_{B_ON}	$C_{LOAD} = 4.7nF$	0.85	1.55	2.35	μs
Turn-off blanking time ⁽⁵⁾	T_{B_OFF}	$C_{LOAD} = 4.7nF$		160		ns
Turn-off blanking V_{DS} threshold	V_{B_OFF}		1.2	1.7	2.2	V
Turn-off threshold on SYNC	V_{SYN}		1.8	2.12	2.5	V
Internal pull-down current on SYNC		$V_{SYN} = 5V$		10	15	μA
Light-load enter SYNC duration	T_{SYN}		70	95	125	μs
Light-load enter pulse width	T_{LL}	$R_{LL} = 100k\Omega$	1.4	1.95	2.5	μs
Light-load enter pulse width hysteresis	T_{LL-H}	$R_{LL} = 100k\Omega$		0.25		μs
Gate disable threshold on LL	V_{LL_DIS}		0.1	0.2	0.3	V
Turn-on threshold (VDS)	V_{LL-DS}	$V_{DD} = 12V$	-320	-220	-120	mV
Gate Driver Section						
VG (low)	V_{G-L}	$I_{LOAD} = 1mA$			0.1	V
VG (high)	V_{G-H}	$V_{DD} > 10V$	10	11.7	13	V
		$V_{DD} \leq 10V$		V_{DD}		
SYNC turn-off propagation delay				45	90	ns
Turn-off propagation delay		$V_D = V_{SS}$		15		ns
Turn-off total delay	T_{Doff}	$V_D = V_{SS}$, $C_{LOAD} = 4.7nF$, $R_{GATE} = 0\Omega$, $V_{GS} = 2V$		40	80	ns
	T_{Doff}	$V_D = V_{SS}$, $C_{LOAD} = 10nF$, $R_{GATE} = 0\Omega$, $V_{GS} = 2V$		50	100	ns
Maximum source current ⁽⁵⁾				0.5		A
Pull-down impedance				0.8	1.6	Ω

NOTE:

5) Guaranteed by characterization or design.

PIN FUNCTIONS

Pin # (SOIC8)	Pin # (TSOT23-6)	Name	Description
1	1	PGND	Power ground. PGND is the return for the driver switch.
2	-	EN	Enable. Active high.
3	2	LL	Light-load timing setting. Connect a resistor to LL to set the light load timing. If LL is not left open, the IC will not enter light-load mode. Pull LL low to disable the gate driver.
4	3	VD	FET drain voltage sense.
5	5	VSS	Ground. VSS is also used as a reference for VD.
6	4	VDD	Supply voltage.
7	-	SYNC	Interface for external signal control. Pull SYNC high to shut down the gate driver immediately.
8	6	VG	Gate driver output.

TYPICAL PERFORMANCE CHARACTERISTICS

$V_{DD} = 12V$, unless otherwise noted.

Operation Current vs. Temperature

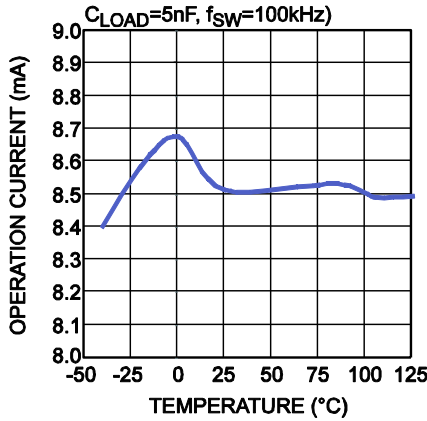

Light-Load Mode Current vs. Temperature

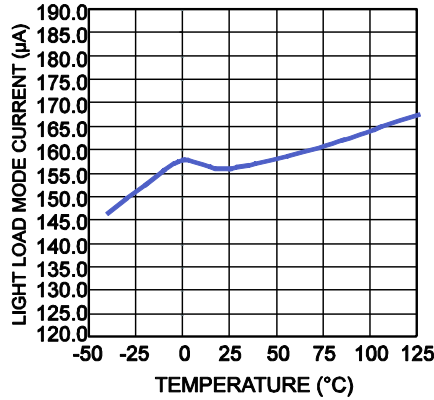

EN UVLO Rising vs. Temperature

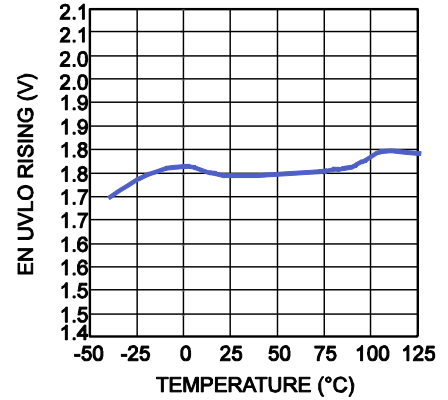

Turn-On Delay vs. Temperature

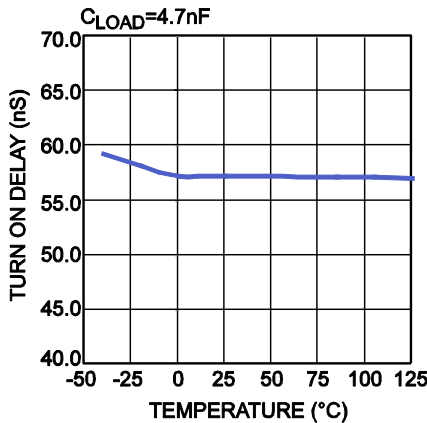

Turn-On Delay vs. Temperature

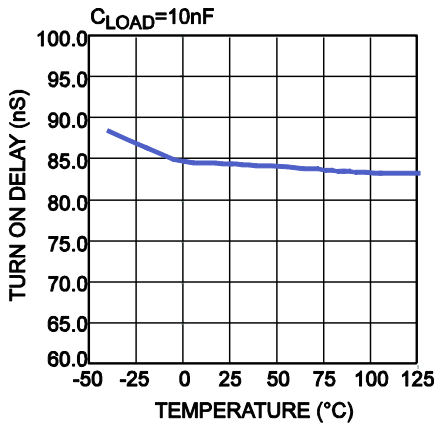

Turn-Off Delay vs. Temperature

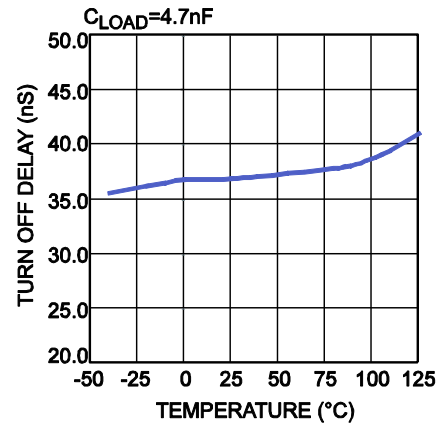

Turn-Off Delay vs. Temperature

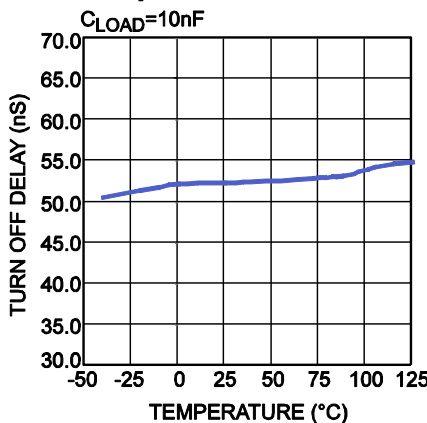

Minimum On Time vs. Temperature

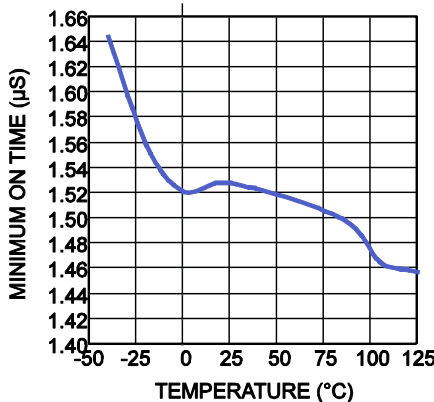

Light-Load Enter Pulse Width vs. Temperature

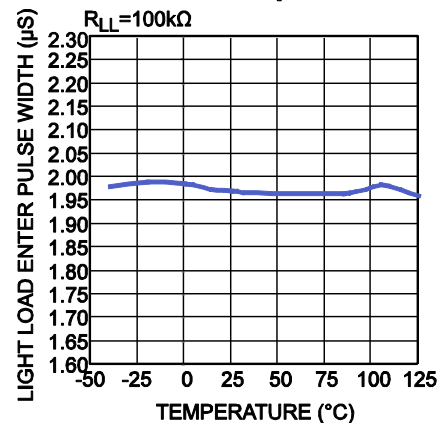

TYPICAL PERFORMANCE CHARACTERISTICS *(continued)*

$V_{DD} = 12V$, unless otherwise noted.

$V_{SS}-V_D$ Forward Voltage vs. Temperature

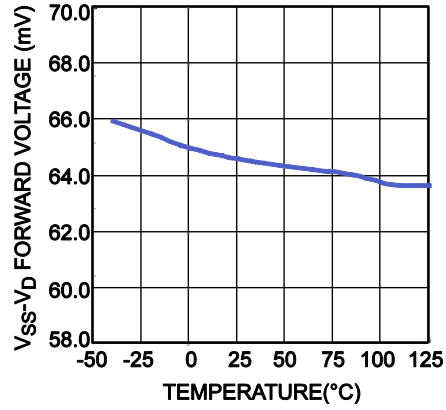

TYPICAL PERFORMANCE CHARACTERISTICS (continued)
 $V_{DD} = 12V$, unless otherwise noted.

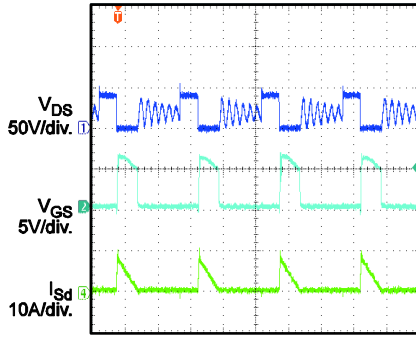
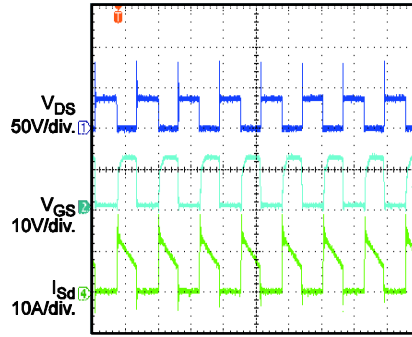
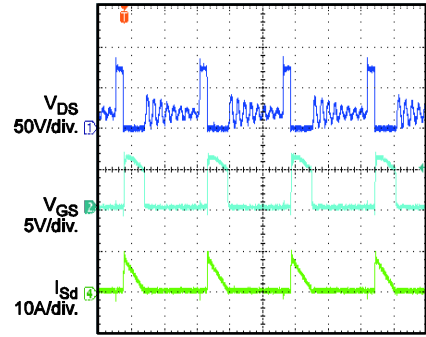
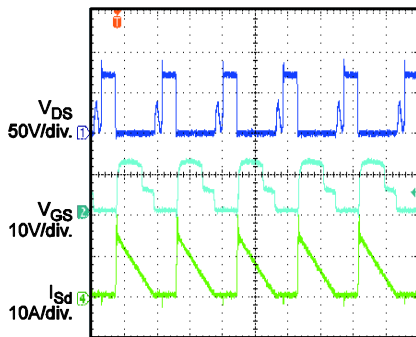
Operation in 90W Flyback Application
 $V_{IN}=90Vac$ $I_{OUT}=1A$

 $10\mu s/div.$
Operation in 90W Adapter Application
 $V_{IN}=90Vac$ $I_{OUT}=4.7A$

 $10\mu s/div.$
Operation in 90W Flyback Application
 $V_{IN}=250Vac$ $I_{OUT}=1A$

 $10\mu s/div.$
Operation in 90W Adapter Application
 $V_{IN}=250Vac$ $I_{OUT}=4.7A$

 $10\mu s/div$
NOTE:

6) See Figure 20 for the test circuit.

BLOCK DIAGRAM

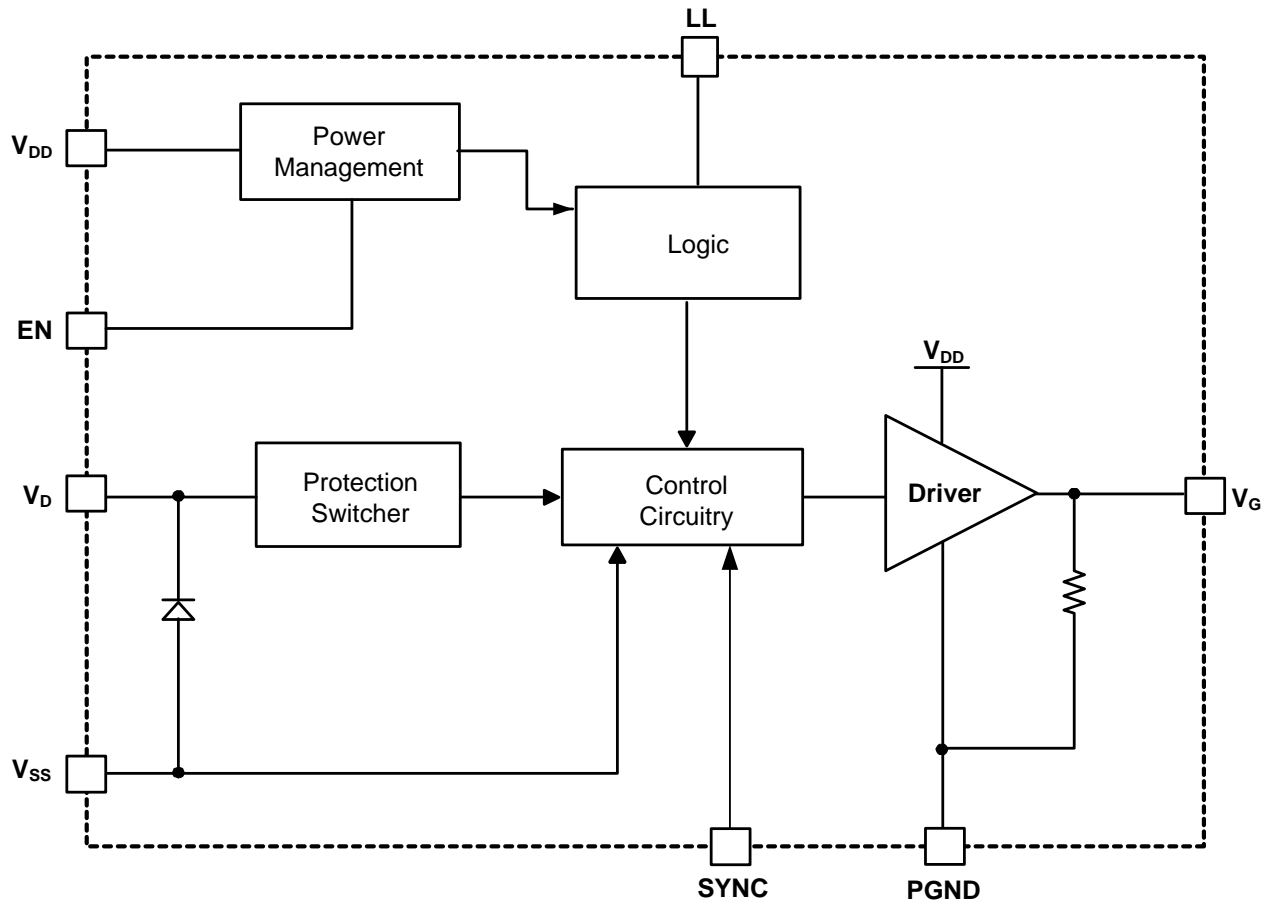

Figure 1: Functional Block Diagram

OPERATION

The MP6907 supports flyback converter operation in continuous conduction mode (CCM), discontinuous conduction mode (DCM), and quasi-resonant mode. The control circuitry controls the gate in forward mode and turns the gate off when the MOSFET current is fairly low.

VD Clamp

Because VD can rise as high as 180V, a high-voltage JFET is used at the input. To avoid excessive currents when VG drops below -0.7V, a 1kΩ resistor is recommended between VD and the drain of the external MOSFET.

Under-Voltage Lockout (UVLO)

When VDD is below the 4.2V UVLO threshold, the MP6907 enters sleep mode, and VG remains at a low level.

Enable (EN)

If EN is pulled low, the MP6907 is in shutdown mode, which consumes ~150μA of shutdown current. If EN is pulled high during the rectification cycle, the gate driver will not start until the next rectification cycle begins (see Figure 2).

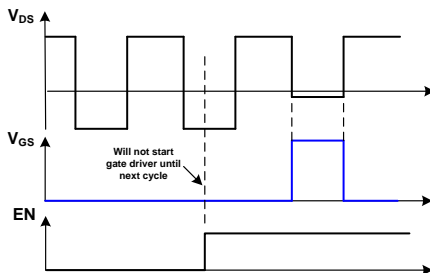

Figure 2: EN Control Scheme

Thermal Shutdown

If the junction temperature of the chip exceeds 150°C, VG is pulled low, and the MP6907 stops switching. The MP6907 resumes normal operation after the junction temperature drops to 140°C.

Turn-On Phase

When the switch current flows through the body diode of the MOSFET, there is negative V_{DS} ($V_D - V_{SS}$) across the MOSFET. The V_{DS} is much lower than the forward voltage drop of the control circuitry (-70mV), which then turns on the MOSFET after a turn-on delay (see Figure 3).

Turn-On Blanking

The control circuitry contains a blanking function. When the MOSFET turns on, the control circuit ensures that the on state lasts for a specific period of time. The turn on blanking time is ~1.6μs, during which the turn-off threshold is blanked (see Figure 3).

Conduction Phase

When V_{DS} rises above the forward voltage drop (-70mV) according to the decrease of the switching current, the MP6907 pulls down the gate voltage level to make the on resistance of the synchronous MOSFET larger to ease the rise of V_{DS} .

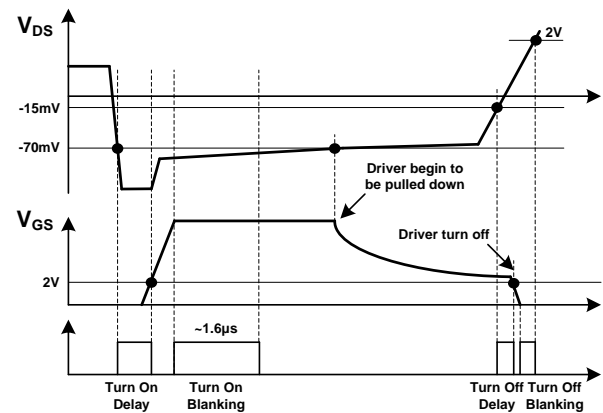

Figure 3: Turn On/Off Timing Diagram

With this control scheme, V_{DS} is adjusted to be around -70mV, even when the current through the MOSFET is fairly low. The function keeps the driver voltage at a very low level when the synchronous MOSFET is turned off, which boosts the turn-off speed.

Turn-Off Phase

When V_{DS} rises to trigger the turn off threshold (-15mV), the gate voltage is pulled to zero after a very short turn-off delay (see Figure 3).

SYNC Turn-Off for CCM Operation

An external turn-off signal can be applied on SYNC to turn off the gate driver signal, which can provide a more reliable operation in CCM.

A rising edge that exceeds 2V applied on SYNC turns off the gate driver signal immediately (see Figure 4).

The gate driver of the MP6907 remains low for as long as the SYNC voltage is high.

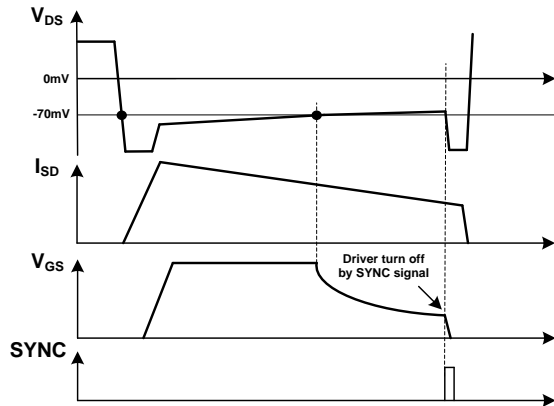

Figure 4: SYNC Turn-Off for CCM

Turn-Off Blanking

After the gate driver is pulled to zero by V_{DS} reaching the turn-off threshold (-15mV), a turn-off blanking time is applied, during which the gate driver signal is latched off. The turn-off blanking is removed when V_{DS} rises above 2V (see Figure 3)

Light-Load Latch-Off Function

The gate driver of the MP6907 is latched off to save driver loss and improve efficiency during light-load condition.

When the synchronous MOSFET conducting period stays lower than T_{LL} for longer than the light-load enter delay ($T_{LL-Delay}$), the MP6907 enters light-load mode and latches off the gate driver (see Figure 5). The synchronous MOSFET conducting period lasts from the time the gate driver turns on to when V_{GS} drops below 1V (V_{LL-GS}).

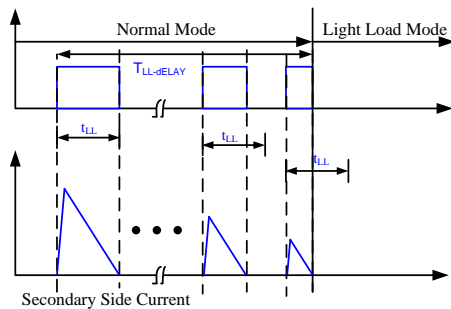

Figure 5: MP6907 Entering Light-Load Mode

The light-load enter time (T_{LL}) is programmable by connecting a resistor (R_{LL}) to LL. By monitoring the LL current, T_{LL} is set. The LL voltage remains at ~2V internally. Calculate T_{LL} with Equation (1):

$$T_{LL} = R_{LL}(k\Omega) \cdot \frac{1.95\mu s}{100k\Omega} \quad (1)$$

During light-load mode, the MP6907 monitors the synchronous MOSFET body diode conducting period by sensing the time duration when V_{DS} is below -250mV (V_{LL-DS}). If it is longer than $T_{LL} + T_{LL-H}$ (the light-load enter pulse-width hysteresis), light-load mode ends, and the gate driver is unlatched to restart synchronous rectification (see Figure 6).

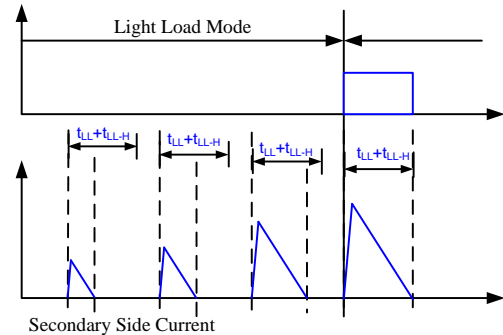

Figure 6: MP6907 Exiting Light-Load Mode

The MP6907 also enters light-load mode when the SYNC voltage is pulled high (>2V) for more than 100µs. Light-load mode ends once the SYNC voltage is pulled low (see Figure 7).

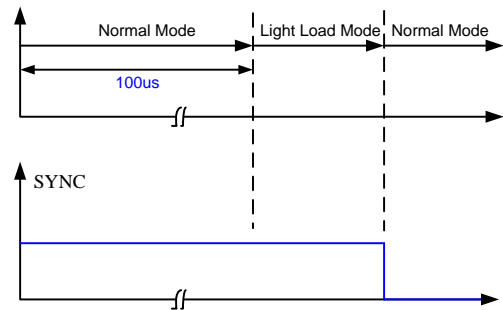

Figure 7: Light-Load Mode Controlled by SYNC

If light-load mode ends during the rectification cycle, the gate driver signal will not appear until the next rectification cycle begins (see Figure 8)

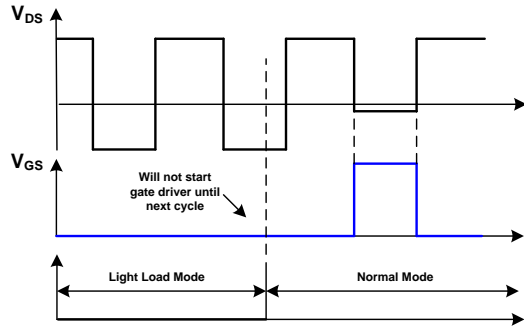

Figure 8: Gate Driver Starts after Exiting Light-Load Mode

Typical System Implementations

Figure 9 shows the typical system implementation for the IC power supply directly derived from the output voltage, which is available in low-side rectification.

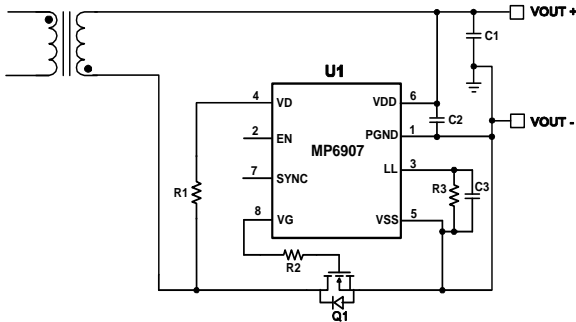

Figure 9: IC Power Derived from Output Voltage

The IC benefits from a wide VDD operating range (4.2V to 35V). The MP6907 supports most application fields with low-side rectification by deriving the supply power from the system output directly.

If the output voltage is out of the VDD operating range or high-side rectification is used, an auxiliary winding solution for the IC's power supply is recommended (see Figure 10 and Figure 11). The auxiliary winding turn count (N_{au}) can be set using Equation (2):

$$N_{au} = \frac{V_{DD}}{V_{OUT}} \cdot N_s \quad (2)$$

Where N_s is the secondary winding turn count.

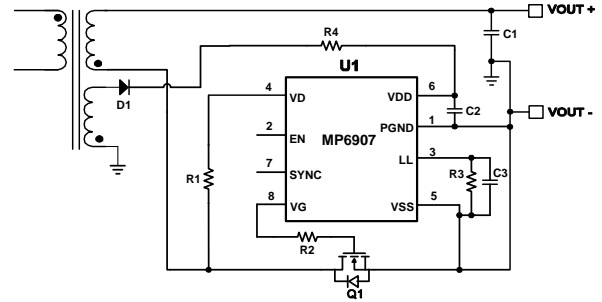

Figure 10: IC Power Derived from the Auxiliary Winding in Low-Side Rectification

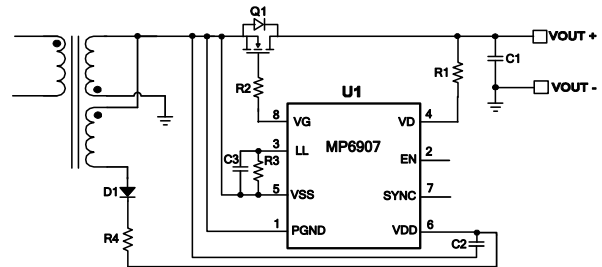

Figure 11: IC Power Derived from the Auxiliary Winding in High-Side Rectification

A simple non-auxiliary winding solution for the IC's power supply is shown in Figure 12 and Figure 13. The IC power is derived from the secondary transformer winding through a diode. When using this power solution, ensure that the winding voltage is lower than the higher limit of the VDD operating range (35V).

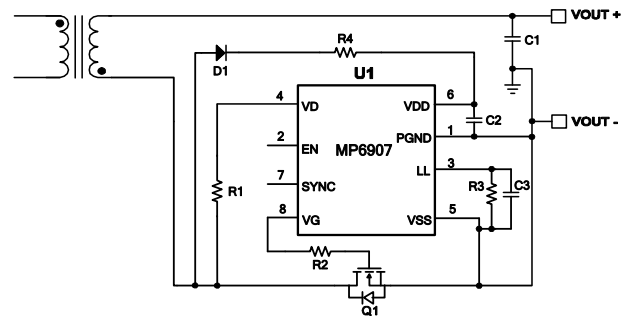

Figure 12: IC Power Derived from the Secondary Winding in Low-Side Rectification

In Figure 12, the winding voltage is $V_s = V_{OUT} + V_{IN_MAX}/n$, where V_{OUT} is the output voltage, V_{IN_MAX} is the maximum input voltage, and n is the transformer turn ratio.

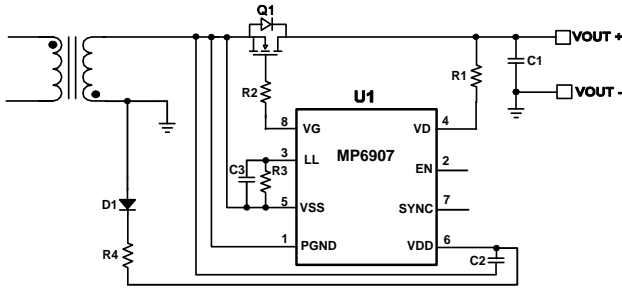

Figure 13: IC Power Derived from the Secondary Winding in High-Side Rectification

In Figure 13, $V_S = V_{IN_MAX}/n$.

If the secondary winding voltage exceeds the higher limit of the VDD operating range (35V), then an external LDO circuit with a Zener diode is needed for the non-auxiliary winding solution (see Figure 14 and Figure 15).

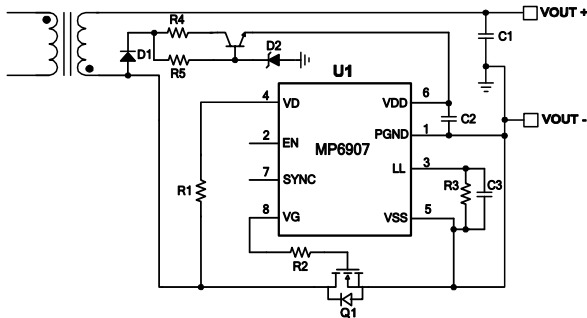

Figure 14: IC Power Derived from the Secondary Winding through an External LDO in Low-Side Rectification

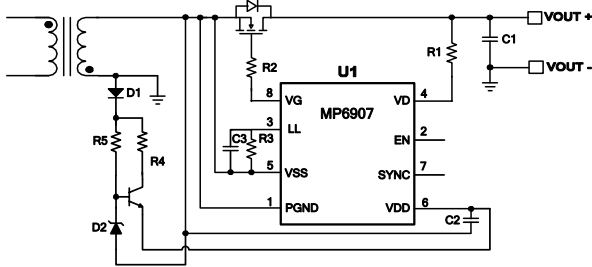

Figure 15: IC Power Derived from the Secondary Winding through an External LDO in High-Side Rectification

SR MOSFET Selection

Power MOSFET selection is a trade-off between $R_{DS(ON)}$ and Q_G . To achieve higher efficiency, a MOSFET with a smaller $R_{DS(ON)}$ is preferred. Typically, Q_G is larger when the $R_{DS(ON)}$ is smaller, which makes the turn-on/off speed lower and leads to larger power loss,

including driver loss. Because V_{DS} is adjusted at about $-70mV$ during the driving period when the switching current is fairly small, a MOSFET with an $R_{DS(ON)}$ that is too low is not recommended because the gate driver will be pulled low when $V_{DS} = -I_{SD} \times R_{DS(ON)}$ becomes larger than $-70mV$. The $R_{DS(ON)}$ of the MOSFET does not contribute to conduction loss. The conduction loss is $P_{CON} = -V_{DS} \times I_{SD} \approx I_{SD} \times 70mV$.

Figure 16 shows the typical waveform of a Q_R flyback, assuming a 50% duty cycle and where I_{OUT} is the output current.

To achieve a fairly high use of the MOSFET's $R_{DS(ON)}$, the MOSFET should be turned on completely for at least 50% of the SR conduction period. Calculate V_{DS} with Equation (3):

$$V_{ds} = -I_c \times R_{on} = -2 \cdot I_{OUT} \times R_{on} \leq -V_{fwd} \quad (3)$$

Where V_{DS} is the drain-source voltage of the MOSFET, and V_{fwd} is the forward voltage threshold ($\sim 70mV$).

The MOSFET's $R_{DS(ON)}$ is recommended to be no lower than $\sim 35/I_{OUT}$ (m Ω). For example, for a 5A application, the $R_{DS(ON)}$ of the MOSFET is recommended to be no lower than 7m Ω .

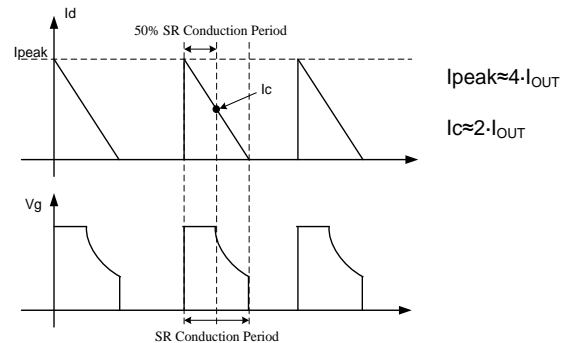

Figure 16: Synchronous Rectification Typical Waveforms in Q_R Flyback

PCB Layout Guidelines

Efficient PCB layout is critical for stable operation. For best results, refer to Figure 17, Figure 18, and Figure 19, and follow the guidelines below.

Sensing for VD/VSS

- 1) Make the sensing connection (VD/VSS) as close as possible to the MOSFET (drain/source).
- 2) Make the sensing loop as small as possible
- 3) Place the VD resistor close to VD.
- 4) Keep the IC out of the power loop to prevent the sensing loop and power loop from interrupting each other (see Figure 17).

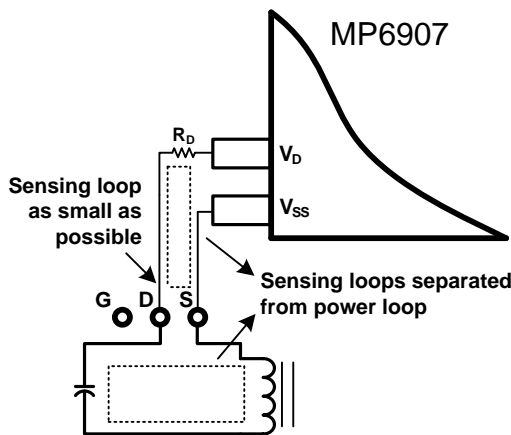

Figure 17: Voltage Sensing for V_D/V_{SS} on MP6907

- 5) Place a decoupling ceramic capacitor no smaller than $1\mu\text{F}$ from VDD to PGND close to the IC for adequate filtering.

Gate Driver Loop

- 1) Make the gate driver loop as small as possible to minimize parasitic inductance.
- 2) Keep the driver signal far away from the VD sensing trace on the layout.

Layout Example

Figure 18 shows a layout example of a single layer with a through-hole transformer and a TO220 package SR FET. R_{SN} and C_{SN} are the RC snubber network for the SR FET.

The sensing loop (VD and VSS to the SR FET) is minimized and kept separate from the power loop. The VDD decoupling capacitor (C_4) is placed beside VDD.

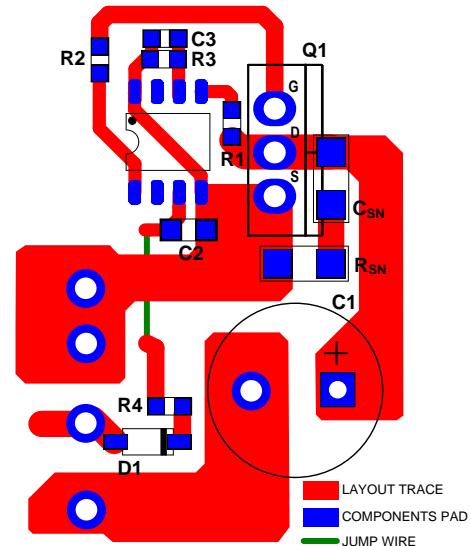

Figure 18: Layout Example with TO220 Package SR FET

Figure 19 shows another layout example of a single layer with a PowerPAK/SO8 package SR FET, which also has a minimized sensing loop and power loop to prevent the loops from interfering with one another.

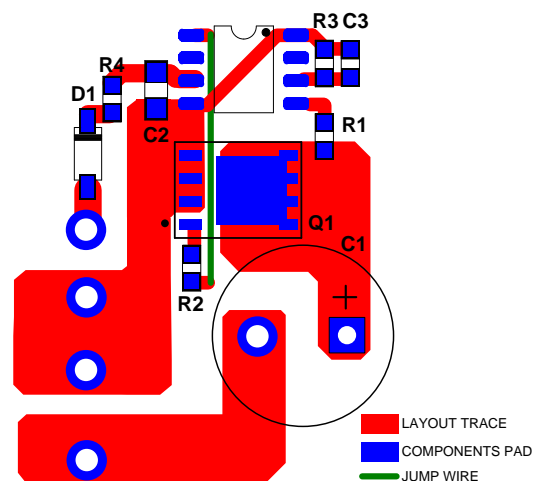

Figure 19: Layout Example with PowerPAK/SO8 Package SR FET

TYPICAL APPLICATION CIRCUIT

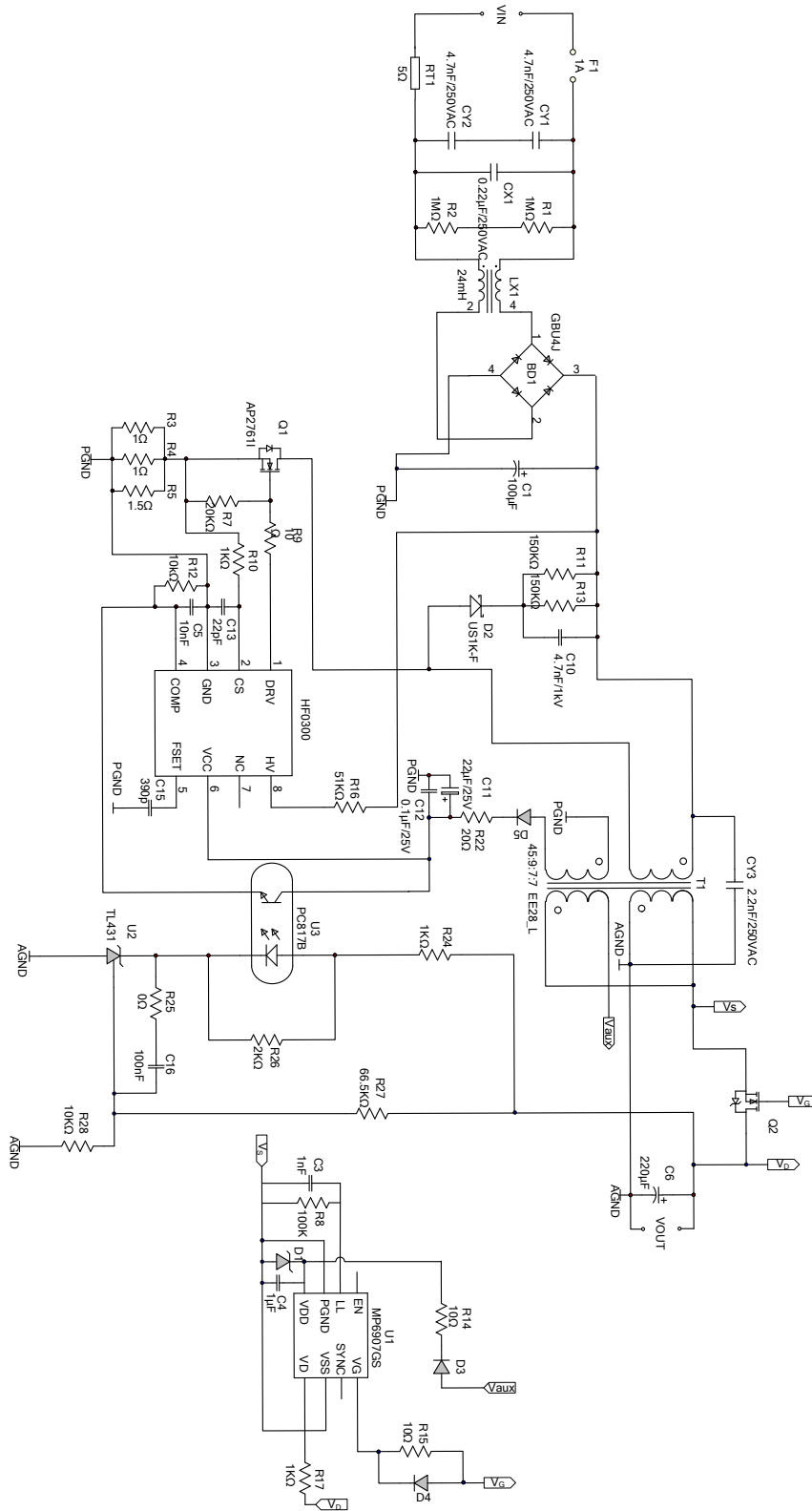
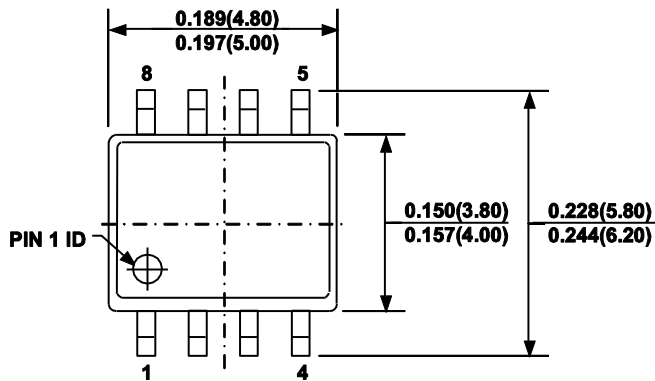

Figure 20: MP6907 for a Secondary Synchronous Controller in a 90W Flyback Application

PACKAGE INFORMATION

SOIC8



TOP VIEW

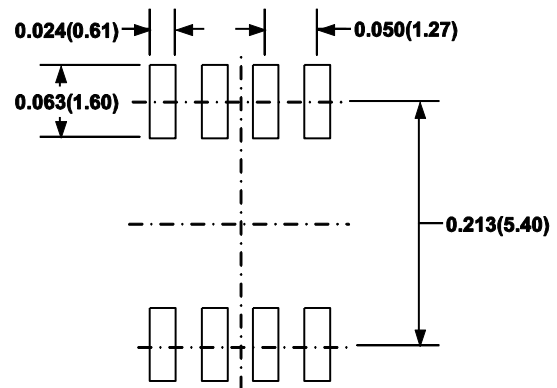

RECOMMENDED LAND PATTERN

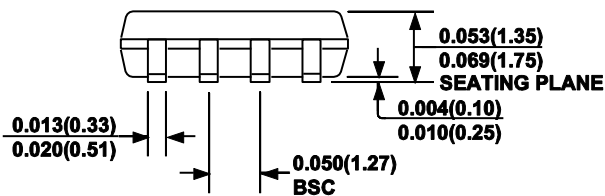

FRONT VIEW

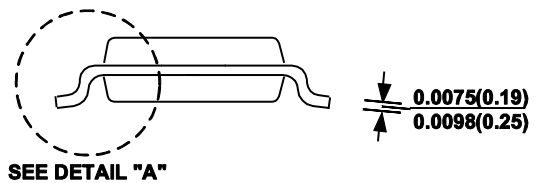

SIDE VIEW

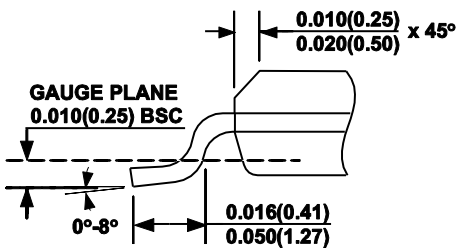

DETAIL "A"

NOTE:

- 1) CONTROL DIMENSION IS IN INCHES. DIMENSION IN BRACKET IS IN MILLIMETERS.
- 2) PACKAGE LENGTH DOES NOT INCLUDE MOLD FLASH, PROTRUSIONS OR GATE BURRS.
- 3) PACKAGE WIDTH DOES NOT INCLUDE INTERLEAD FLASH OR PROTRUSIONS.
- 4) LEAD COPLANARITY (BOTTOM OF LEADS AFTER FORMING) SHALL BE 0.004" INCHES MAX.
- 5) DRAWING CONFORMS TO JEDEC MS-012, VARIATION AA.
- 6) DRAWING IS NOT TO SCALE.

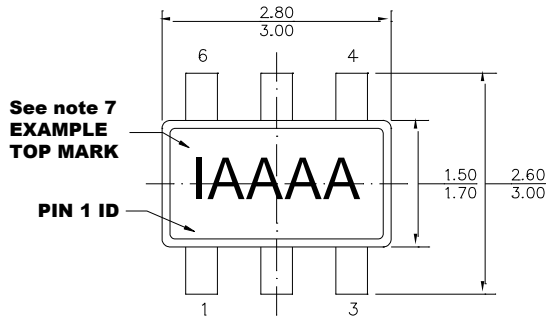
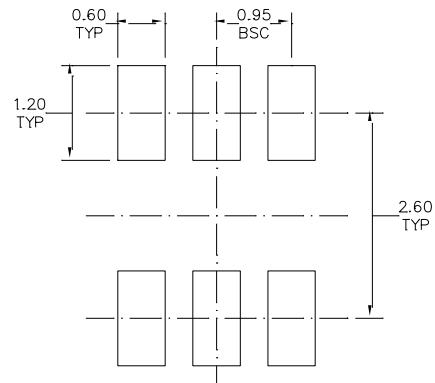
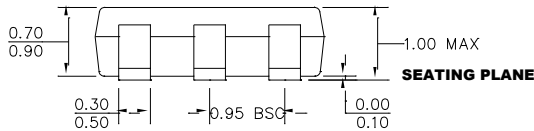
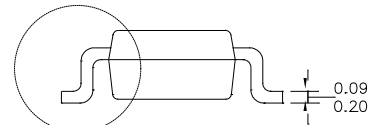
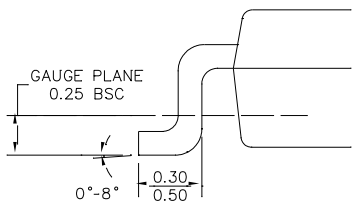
PACKAGE INFORMATION (continued)
TSOT23-6

TOP VIEW

RECOMMENDED LAND PATTERN

FRONT VIEW

SIDE VIEW
NOTE:

DETAIL "A"

- 1) ALL DIMENSIONS ARE IN MILLIMETERS.
- 2) PACKAGE LENGTH DOES NOT INCLUDE MOLD FLASH, PROTRUSION OR GATE BURR.
- 3) PACKAGE WIDTH DOES NOT INCLUDE INTERLEAD FLASH OR PROTRUSION.
- 4) LEAD COPLANARITY (BOTTOM OF LEADS AFTER FORMING) SHALL BE 0.10 MILLIMETERS MAX.
- 5) DRAWING CONFORMS TO JEDEC MO-193, VARIATION AB.
- 6) DRAWING IS NOT TO SCALE.
- 7) PIN 1 IS LOWER LEFT PIN WHEN READING TOP MARK FROM LEFT TO RIGHT, (SEE EXAMPLE TOP MARK)

NOTICE: The information in this document is subject to change without notice. Users should warrant and guarantee that third party Intellectual Property rights are not infringed upon when integrating MPS products into any application. MPS will not assume any legal responsibility for any said applications.