



# EV2639C-R-00A

## Reference Design for MP2639C, 2- Cell Li-ion or Li-polymer Switching Charger with 5V input Integrated Bidirectional Charge/Discharge

### DESCRIPTION

The EV2639C-R-00A is the reference design board for MP2639C, a highly-integrated, flexible switch-mode battery charge management for 2-cell series Li-ion and Li-Polymer battery used in a wide range of applications.

The demo board uses two operating modes—charge mode and discharge mode—to allow management of system and battery power based on the state of the input.

When input power is present, the board charges a 2-cell series battery with 2.5A charge current.

In the absence of an input source, the board switches to discharge mode through the PB pin to power the system from the battery with 5A.

The evaluation board provides 4-LED drivers to achieve the voltage based fuel gauge indication and distinguish charge mode from discharge mode.

To guarantee safe operation, the EV2639C-R-00A has input-over-voltage protection, battery over-voltage protection, thermal shutdown, battery-temperature monitoring, and a charge timer to prevent prolonged charging a dead battery.

### FEATURES

- 4V-to-5.75V Operating Input Voltage Range
- Charge 2-cell Battery With 5V Input
- Power Management Function Integrated Input-Current-Limit and Input Voltage Regulation
- 2.5A Charge Current
- 8.4V Charge Voltage with 0.5% Accuracy
- Battery Temperature Monitoring
- 4-LED drivers for battery fuel gauge indication
- Charge Timer Back-Up Protection
- Battery-Reverse-Leakage Blocking
- Reverse-Buck Operation for Powering System
- 92.5% 5V discharge Mode Efficiency @ 5A with BATT=8.4V
- 5A Output Current Limit in discharge Mode

### APPLICATIONS

- Sub-battery Applications
- Power-bank Applications for Smart-Phone, Tablet and Other Portable Devices

All MPS parts are lead-free, halogen free, and adhere to the RoHS directive. For MPS green status, please visit MPS website under Quality Assurance.

"MPS" and "The Future of Analog IC Technology" are Registered Trademarks of Monolithic Power Systems, Inc.

### ELECTRICAL SPECIFICATION

Parameter	Symbol	Value	Units
<b>Charge Mode</b>			
Input Voltage Range	$V_{IN}$	4 – 5.75	V
Charge-Full Voltage	$V_{BATT\_Full}$	8.4	V
Charge Current	$I_{CHG}$	2.5	A
Input Current Limit	$I_{IN\_LIM}$	2.7	A
<b>Discharge Mode</b>			
Battery Voltage	$V_{BATT}$	5.75-8.4	V
Output Voltage Regulation	$V_{OUT}$	5	V
Output Current Limit	$I_{OUT}$	5	A

## EV2639C-R-00A EVALUATION BOARD

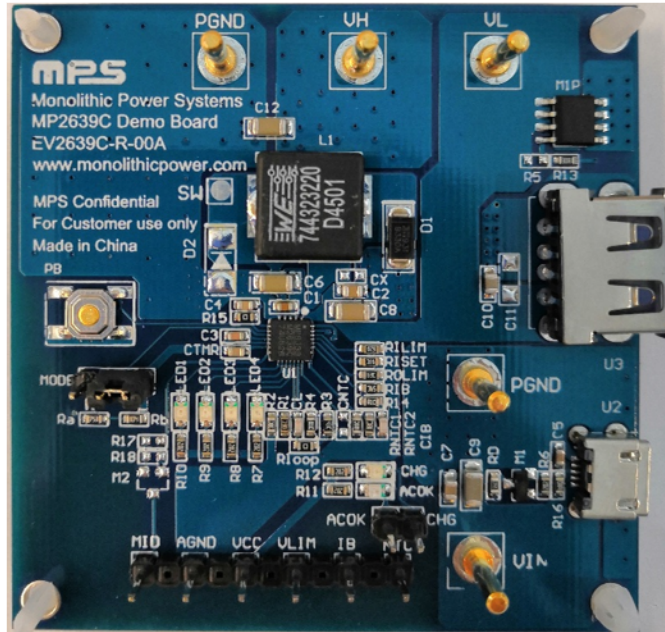

(L x W x H)  
(63.5mm x 63.5mm x 0.16cm)

Board Number	MPS IC Number
EV2639C-R-00A	MP2639CGR

**EVALUATION BOARD SCHEMATIC**

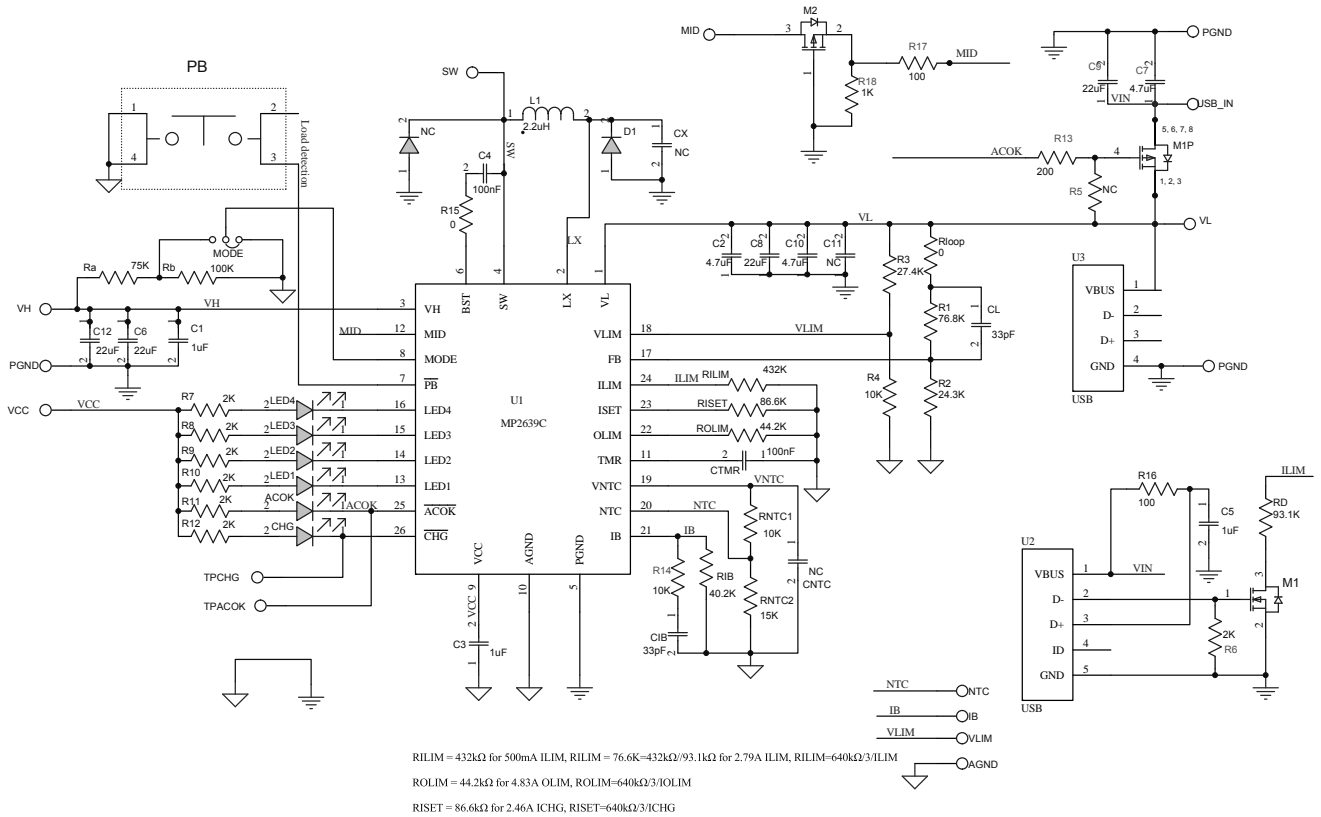



EV2639C-R-00A –2.5A BOOST CHARGER, 5A DISCHARGE  
2-CELL SERIES SWITCH MODE BATTERY CHARGER

EV2639C-R-00A BILL OF MATERIALS

Qty	Ref	Value	Description	Package	Manufacturer	Part Number
5	CHG, LED1, LED2, LED3, LED4	BL-HUF35A- TRB	LED; green;	0805	BRIGHT LED	BL-HUF35A-TRB
1	ACOK	BL-HGB35A- TRB	LED; red;	0805	BRIGHT LED	BL-HGB35A-TRB
4	C1, C3, C5,	1 $\mu$ F	Ceramic Capacitor; 25V;X7R;0603;	0603	Murata	GRM188R71E105KA12D
3	C2, C7, C10	4.7 $\mu$ F	Ceramic Capacitor; 25V;X5R;0805;	0805	Murata	GRM21BR61E475KA12L
2	C4, CTMR	100nF	Ceramic Capacitor; 50V;X7R;0603;	0603	Murata	GRM188R71H104KA93D
4	C6, C8, C9, C12	22 $\mu$ F	Capacitor;25V;X5R	1206	Murata	GRM31CR61E226KE15L
1	C11,Cx	NC	Capacitor;25V;X5R	1206	Murata	GRM31CR61E226KE15L
2	C1B, CL	33pF	Ceramic Capacitor; 50V;C0G;0603	0603	TDK	C1608C0G1H330J
1	CNTC	NC	Ceramic Capacitor; 25V;X7R;0603;	0603	Murata	GRM188R71E105KA12D
1	D1	B330A	Schottky Diode; 30V;3A;	SMA	Diodes	B330A
1	D2	NC				
1	L1	2.2 $\mu$ H	Inductor;2.2 $\mu$ H; 9A	SMD	Wurth	744323220
1	M1	2N7002-F	N-Channel Mosfet; 60V;7500;115m	SOT-23		2N7002-F
1	M1P		P Channel MOSFET	SO-8		AM4825-P
1	PB	Push Switching button	Button; SM 4x10mm; 1.5mm Height			
1	R1	76.8k $\Omega$	Film Resistor;1%	0603	Yageo	RC0603FR-0776K8L
1	R2	24.3k $\Omega$	Film Resistor;1%	0603	Yageo	RC0603FR-0724K3L
1	R3	27.4k $\Omega$	Film Resistor;1%	0603	Yageo	RC0603FR-0727K4L
2	R4, RNTC1,R14	10k $\Omega$	Film Resistor;1%;	0603	Yageo	RC0603FR-0710KL
2	Rb	100k $\Omega$	Film Resistor;5%;	0603	Yageo	RC0603JR-07100KL
8	R6, R7, R8, R9, R10, R11, R12	2k $\Omega$	Film Resistor;5%;	0603	Yageo	RC0603JR-072KL
3	R5,R17,R18	NC				
1	R13	200	Film Resistor;5%;	0603	Yageo	RC0603JR-07200RL
2	R15, Rloop	0	Film Resistor;5%;	0603	Yageo	RC0603JR-070RL
1	R16	100	Film Resistor;5%;	0603	Yageo	RC0603JR-07100RL
1	Ra	75k $\Omega$	Film Resistor;5%;	0603	Yageo	RC0603JR-0775KL
1	RD	93.1k $\Omega$	Film Resistor;1%	0603	Yageo	RC0603FR-0793K1L
1	RIB	40.2k $\Omega$	Film Resistor;1%;	0603	Yageo	RC0603FR-0740K2L
1	RILIM	432k $\Omega$	Film Resistor;1%	0603	Yageo	RC0603FR-07432KL
1	RISET	86.6k $\Omega$	Film Resistor;1%	0603	Yageo	RC0603FR-0786K6L
1	RNTC2	15k $\Omega$	Film Resistor;1%;	0603	Yageo	RC0603FR-0715KL



**EV2639C-R-00A BILL OF MATERIALS** *(continued)*

Qty	Ref	Value	Description	Package	Manufacturer	Part Number
1	ROLIM	44.2kΩ	Film Resistor;1%;	0603	Yageo	RC0603FR-0744K2L
1	U1		MP2639CGR	QFN4x4-26	MPS	MP2639CGR
1	U2	629105136821	micro-USB		Wurth	629105136821
1	U3	USB'				

## PRINTED CIRCUIT BOARD LAYOUT

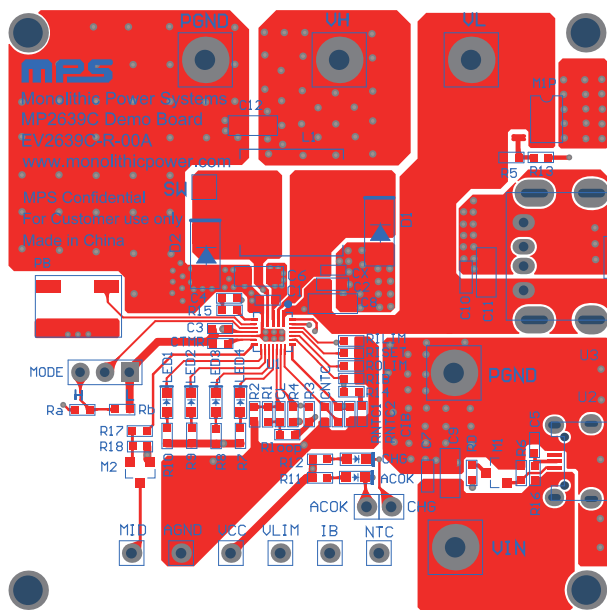

Figure1: Top Layer

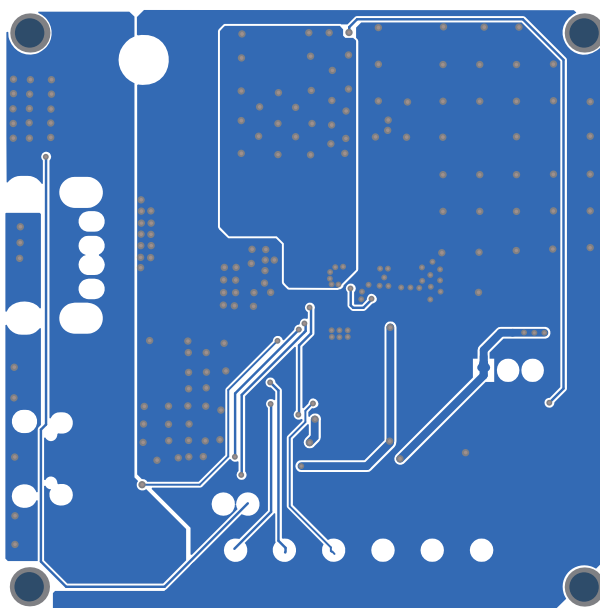

Figure 2: Bottom Layer

## QUICK START GUIDE

This demo board is reference design for MP2639C, flexible switch-mode battery charging management device for 2-cell series Li-ion and Li-Polymer battery pack used in a wide range of portable applications through the boost converter from VL to VH. This part could also works in discharging mode which could discharge the 2 cell battery to the load, from VH to VL.

The board's layout accommodates most commonly-used capacitors. The default function of this board is preset at charge mode, and the charge full voltage is preset to 8.4V for a 2-cell series Li-Ion battery.

### Charge Mode Setting

#### 1. Input Current Limit

The input current limit can be set slightly below the input source's maximum current rating. When the input current hits this limit, the charge current could decrease to keep the input current constant at the limit value to initially power the system.  $R_{ILIM}$ —the resistor connected to the ILIM pin—programs this limit. To set the input current limit at 2.7A, use an  $R_{ILIM}$  of 79k $\Omega$ .

$$I_{INLIMIT} = \frac{640k}{3 \times R_{ILIM}} \quad (1)$$

#### 2. Charge Current

The charge current can be programmed via  $R_{ISET}$ . Determine the charge current using the following formula:

$$I_{CHG} = \frac{640k}{3 \times R_{ISET}} \quad (2)$$

For 2.5A charge current, the given  $R_{ISET}$  is 85.3k $\Omega$ .

#### 3. Input Voltage Limit

The input voltage clamp threshold can programmable by the VLIM pin. The internal reference of the input voltage loop is 1.2V, so the input voltage clamp limit would be,

$$V_{INLIMIT} = 1.2 \times \frac{R_3 + R_4}{R_4} \quad (3)$$

Here,  $R_3=27.4k\Omega$ ,  $R_4=10k\Omega$ , the input voltage clamp value is 4.49V.

### Discharge Mode Setting

#### 1. System-Output-Current Limit

Set the system-output-current limit in buck mode for the EV2639C to operate like a standard adapter. Set the output current limit as per the following equation:

$$I_{OLIM} = \frac{640k}{3 \times R_{OLIM}} \quad (4)$$

For 5A output current limit, the given  $R_{OLIM}$  is 42.6k $\Omega$ .



## EQUIPMENT REQUIREMENT

Evaluation requires the following equipments:

1. For the charge input, USB cable with an adaptor or any USB port with load capability can be directly used for the reference design board. In case some operation state can't be tested, external wire can be added to connect a power source with 6V/3A capability.
2. Battery simulator or 2-cell battery pack. The battery simulator's output rating should exceed 9V/7.0A. When using a real battery pack, please observe all precautions on the battery manufacturer's data sheet first and ensure the charger's setting doesn't exceed the battery's absolute maximum specifications.
3. E-load or real smart phone. The E-load capability should exceed 5V/5A.
4. An oscilloscope. A single voltage probe and a single current probe.
5. Multi-meter.

### Charge Function

- 1 Attach the positive(VH) and negative ends(PGND) of the board to the "+" and "-" terminals of the battery or battery simulator, respectively. If it's a battery simulator, please preset the voltage to 7.6V (typical value for 2-cell) first.
- 2 Connect Mode pin to L for Charge mode selection.
- 3 Present the DC source or the USB cable with 5V output.

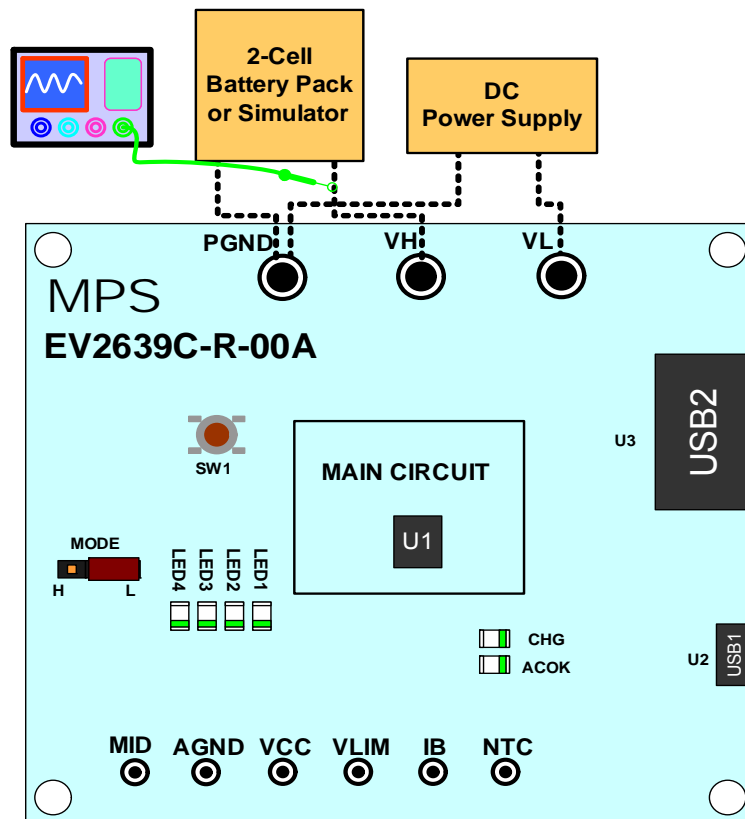

Figure 3: Setup for Charge Mode from DC source



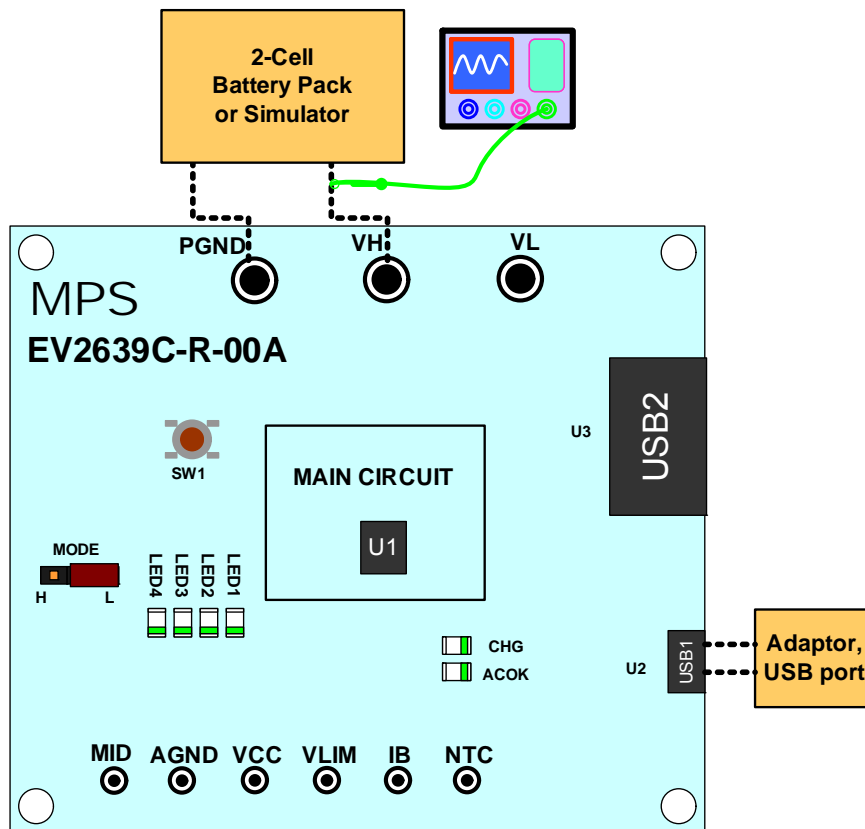

Figure 4: Setup for Charge Mode from USB cable

- 4 Turn on DC source or connect the adaptor or USB port to the demo board, the charge starts. Use the oscilloscope to verify that the charge current is being delivered to the battery, the charge current could be a different value under following conditions:

- a. The charge current could be limited by input current limit.

The IC features the input source detection to decide the input current limit according to the input source (USB or adaptor). The IC sets the input current limit through the ILIM pin. When the input current hits this limit and battery voltage continue to increase, the charge current could decrease to keep the input current constant at the limit value.

- b. The charge current could be limited by the input voltage regulation.

If the input power supply has lower current capability (such as USB port with 500mA only) than the setting input current limit or the voltage drop on USB cable is too big, the input voltage may approach the input voltage regulation threshold (4.49V) preset by R3 and R4. Once the input voltage approaches the input voltage regulation threshold, charge current is reduced to allow priority of system power and maintain the input voltage avoid dropping further.

### Discharge Function

- 1 Connect the E-load to the USB2 or VL on demo board.
- 2 Attach the VH and PGND of the board to the “+” and “-” terminals of the battery or battery simulator respectively. If it’s a battery simulator, please preset the voltage to 7.6V (typical value) firstly.
- 3 Connect Mode pin to high for discharge mode selection.
- 4 Turn on the battery simulator, push the button for shorter than 2.5s, the discharge function is enabled. Then, push the button for longer than 2.5s can shutdown the discharge mode. During discharging mode, push the button for short than 2.5s could lighten LED1-4 for 5s to indicate battery’s voltage.
- 5 Remove the load from USB2, the discharge operation terminates after 16s.

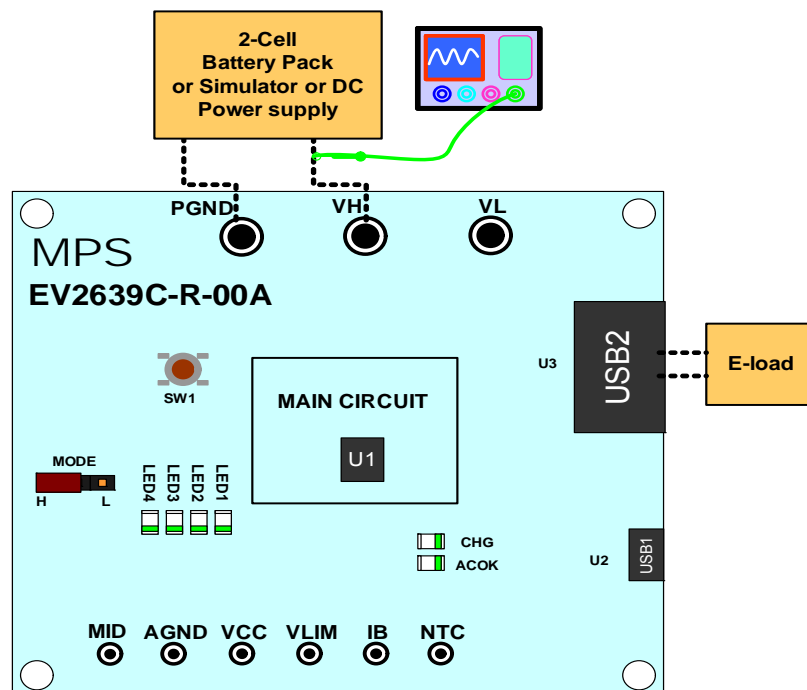

Figure 5: Setup for Discharge Mode with USB2 connected to load

For the other detailed description on the operation of the MP2639C, please refer to the datasheet.

**NOTICE:** The information in this document is subject to change without notice. Users should warrant and guarantee that third party Intellectual Property rights are not infringed upon when integrating MPS products into any application. MPS will not assume any legal responsibility for any said applications.