

DESCRIPTION

The EV2611-L-00A is an evaluation board for MP2611, a 2A/1.5MHz 1-cell switching charger with dual inputs for USB and AC adapter.

For AC mode, MP2611 regulates the charge current and battery voltage using two control loops to realize high accuracy CC and CV charge. The charge current can be set by sensing the current through a sense resistor. And due to the integrated high-side P-MOSFET, 100% duty cycle can be achieved when battery voltage is close to input voltage.

For USB mode, the input current limit can be programmed to 450mA and 810mA via the USBM-pin to cover both the USB2.0 and USB3.0.

ELECTRICAL SPECIFICATION

Parameter	Symbol	Value	Units
AC Input Voltage	V _{ACIN}	4.5 to 6	V
Charge Current	I _{CHG}	0 to 2	A
USB Input Voltage	V _{USBIN}	4.5 to 6	V
USB Input Current Limit	I _{USB LIM}	0 to 2	A
Battery Voltage	V _{BATT}	0 to 4.2	V

FEATURES

- Charge Single-Cell Li-Ion Batteries
- Up to 100% Duty Operation.
- Up to 2A Programmable Charge Current
- ±0.5% Battery Voltage Accuracy
- Dual Separate Inputs for USB and AC Adapter
- Fully Integrated Power Switches
- Programmable Input Current Limit for USB Port
- Charging Operation Indicators
- No External Reverse Blocking Diode Required
- Built-in Programmable Charging Timer
- Thermal Shutdown
- Battery Temperature Monitor and Protection

APPLICATIONS

- Smart Phones
- Portable Hand-Held Terminals
- PDAs
- Media Players

For MPS green status, please visit MPS website under Quality Assurance. "MPS" and "The Future of Analog IC Technology" are Registered Trademarks of Monolithic Power Systems, Inc.

EV2611-L-00A EVALUATION BOARD



(L x W x H) 2.48" x 2.48" x 0.063"
(6.3cm x 6.3cm x 0.16cm)

Board Number	MPS IC Number
EV2611-L-00A	MP2611GL

EVALUATION BOARD SCHEMATIC

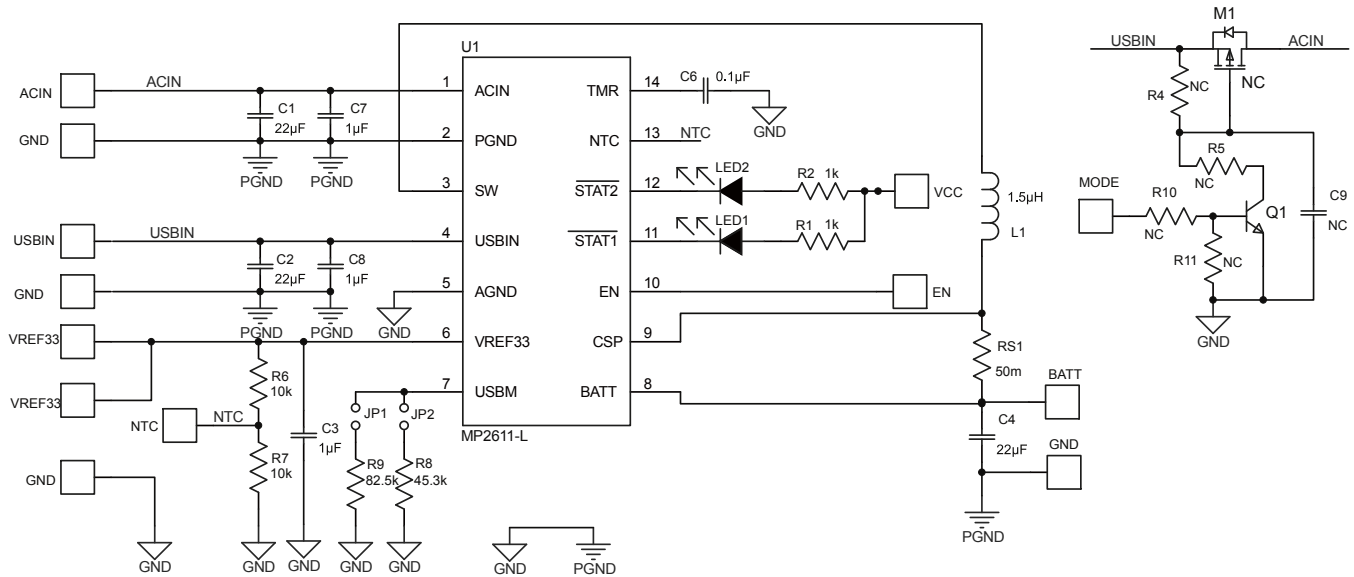

EV2611-L-00A BILL OF MATERIALS

Qty.	Ref.	Value	Description	Package	Manufacturer	Manufacturer P/N
3	C1, C2, C4	22 μ F	Ceramic Capacitor;25V;X7R	1206	Murata	GRM31CR61E226KE15
3	C3, C7, C8	1 μ F	Ceramic Capacitor; 16V;X7R;0603;	0603	muRata	GRM188R71C105KA12D
1	C6	0.1 μ F	Ceramic Capacitor; 16V;X7R;0603	0603	muRata	GRM188R71C104KA01D
1	L1	1.5 μ H	Inductor;1.5 μ H;28mOhm;3.6A	SMD	TDK	LTF5022T-1R5N3N6-LC
			Inductor;1.5 μ H;27.4mOhm;3.23A	SMD	Cooper	SD25-1R5-R
1	LED1	BL-HUF35A-TRB	LED;红光;	0805	BRIGHT LED	BL-HUF35A-TRB
1	LED2	BL-HGE35A-TRB	LED;绿色;	0805	BRIGHT LED	BL-HGE35A-TRB
2	R1, R2	1k	Film Resistor;5%	0603		0603SAJ0102T5E
2	R6, R7	10k	Film Resistor;1%	0603	Yageo	RC0603FR-0710KL
1	R8	45.3k	Film Resistor;1%	0603	Yageo	RC0603FR-0745K3L
1	R9	82.5k	Film Resistor;1%;	0603	Yageo	RC0603FR-0782K5L
1	RS1	50m	Resistor;1%;	1206	Yageo	RL1206FR-070R05L
2	JP1, JP2		2.54mm 短接块			
7	EN, MODE, NTC, VCC, VREF33, GND		1*40 180 度 2.54mm 排针			
5	ACIN, BATT, GND		2.0 公针			
1	USBIN		1.0 公针			
1	U1		Switching Charger IC	QFN14 (3mm x 4mm)	MPS	MP2611GL
1	C9	NC				
4	R4, R5, R10, R11	NC				
1	M1	NC				
1	Q1	NC				

PRINTED CIRCUIT BOARD LAYOUT

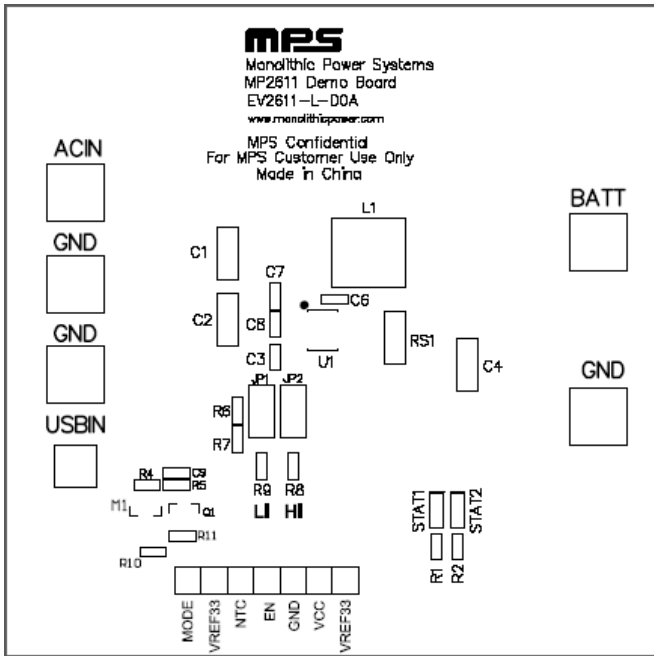

Figure 1— Top Silk Layer

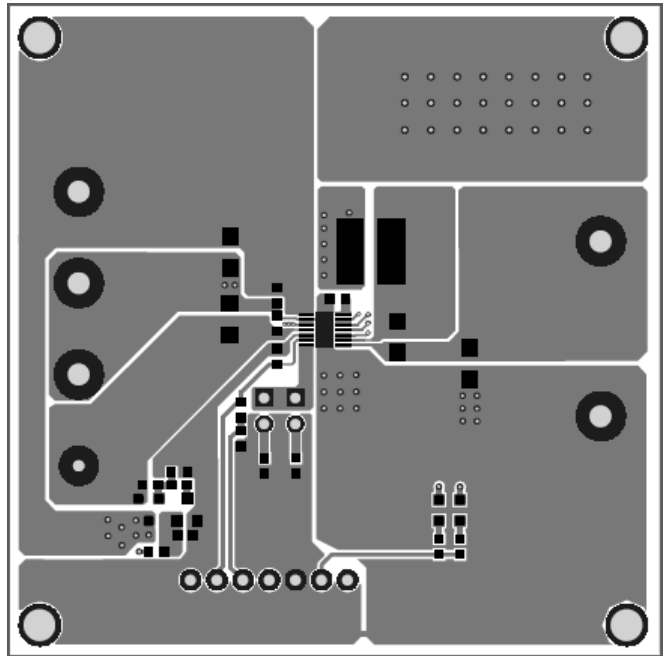

Figure 2—Top Layer

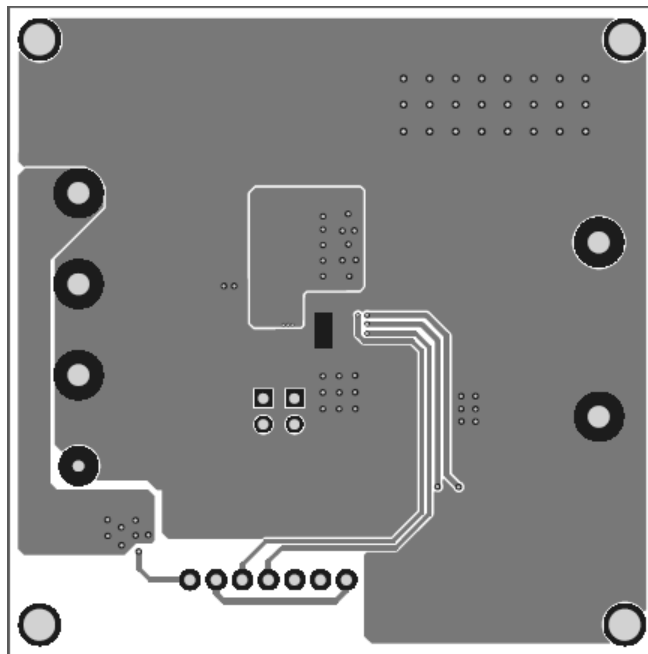

Figure 3—Bottom Layer

QUICK START GUIDE

This board is used for the application of USB/AC compatible battery chargers which can charge a single-cell Li-ion battery. The board layout accommodates most commonly used capacitors.

The EV2611-L-00A evaluation board can work in two modes: AC input mode and USB input mode. For the AC input mode, connect the power source (AC adapter) to “ACIN” and keep “USBIN” float. The charge current can be set by the sense resistor RS1. For the USB input mode, connect the power source (USB port) to “USBIN” and keep “ACIN” float. The USB input current limit loop is implemented and the threshold can be programmed by connecting a resistor (R8 or R9 in the EVB) from USBM-pin to AGND.

Note that if supply for both of “ACIN” and “USBIN”, the “ACIN” will be selected as the power supply of the charger. However, it is not recommended to use like this.

EQUIPMENT REQUIREMENT

Before the evaluation, the following equipments should be prepared:

1. A DC power source. The output voltage range should be greater than 6V, and output current greater than 2A.
2. A battery simulator or a single-cell battery pack. The output rating of battery simulator should be greater than 4.5V/2.5A. While use the real battery pack, please observe all precautions on the battery manufacturer’s data sheet first and then make sure the charger’s setting doesn’t exceed the absolute maximum specification of the battery.
3. An oscilloscope. A single voltage probe and a single current probe are required at least.
4. A multi-meter.

PROCEDURE

1. AC Input Mode Demonstration

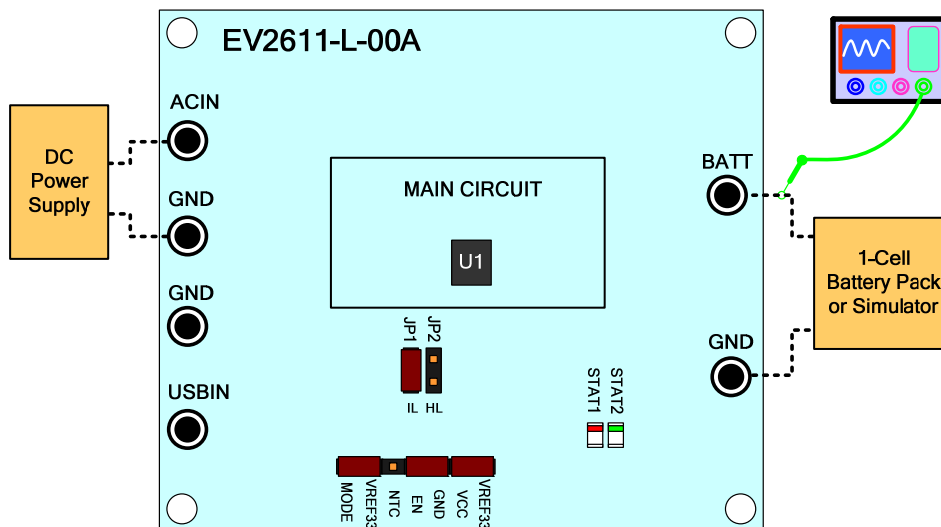

Figure 4—Setup for AC Input Mode

- (1) Connect the jumper “EN” to “GND” and the “VCC” to “VREF33” with a shunt respectively!
- (2) Attach the positive and negative ends of the battery to the “BATT” and “GND” terminals respectively. If it’s a battery simulator, please preset the voltage to 3.8V (typical value) firstly.
- (3) Preset the DC power source to 5V. Then attach the DC output port and ground to the “ACIN” and “GND” terminals, respectively.
- (4) Turn on the DC power source. The charger will start to work. Verify the 2A charge current is being delivered to the battery with the oscilloscope.
- (5) Remove the shunt between the “EN” and “GND” to disable charging.
- (6) Re-insert the shunt between the “EN” and “GND” to enable charging.

2. USB Input Mode Demonstration

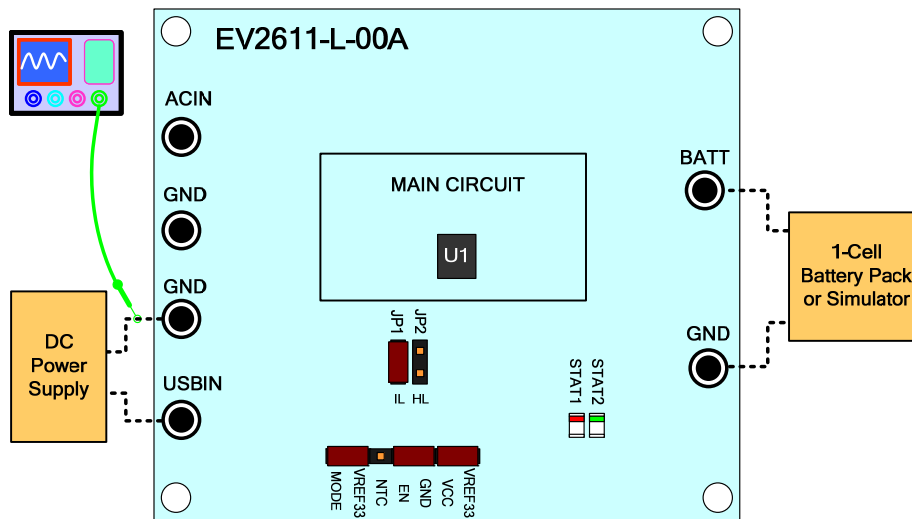

Figure 5—Setup for USB Input Mode

- (1) Connect the jumper “EN” to “GND” and the “VCC” to “VREF33” with a shunt respectively!
- (2) Install a shunt on the jumper JP1.
- (3) Attach the positive and negative ends of the battery to the “BATT” and “GND” terminals respectively. If it’s a battery simulator, please preset the voltage to 3.8V (typical value) firstly.
- (4) Preset the DC power source to 5V. Then attach the DC output port and ground to the “USBIN” and “GND” terminals, respectively.
- (5) Turn on the DC power source. The charger will start to work. Verify the USB input current is limited to 450mA.
- (6) Remove the shunt of JP1 and install it on the neighbor JP2. Verify the USB input current is limited to 900mA.
- (7) Remove the shunt between the “EN” and “GND” to disable charging.
- (8) Install the shunt between the “EN” and “GND” to enable charging.

3. Single Input Application Demonstration

In some applications, the charger has only one input port and identifies the input source (AC adapter or USB port) via a logic signal from MODE-pin. MODE pulled high indicates an AC adapter is connected, low indicates a USB port source.

The EV2611-L-00A demo board offers a single input application solution with an optional “mode control circuit”. Users can experience the function via the following steps.

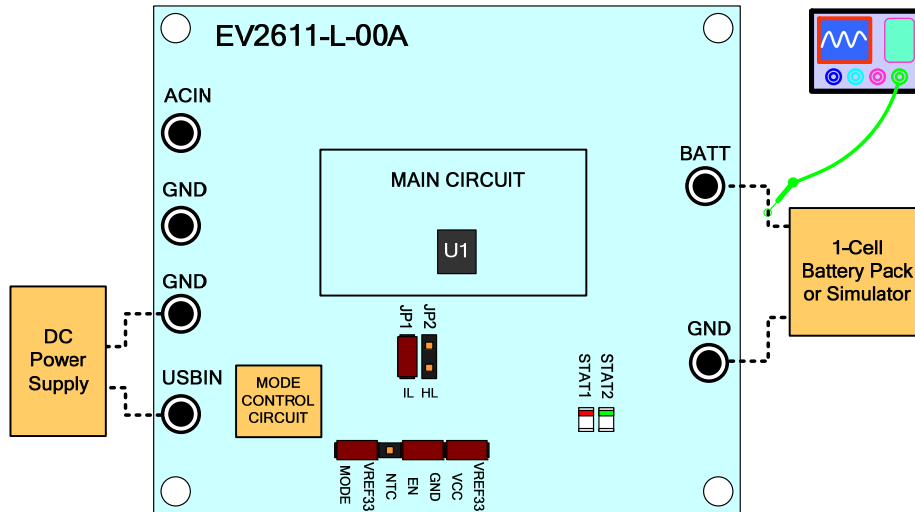

Figure 6—Setup for Single Input Application

- (1) Install the components of “mode control circuit” based on the BOM below:

Table 1—BOM of the Mode Control Circuit

Qty	Ref	Value	Description	Package	Manufacturer	Manufacturer P/N
2	R4, R11	200k	Film Resistor;1%;	0603	Yageo	RC0603FR-07200KL
2	R5, R10	20.5k	Film Resistor;1%;	0603	Yageo	RC0603FR-0720K5L
1	C9	2.2 μ F	Ceramic Capacitor; 10V;X7R;0603	0603	muRata	GRM188R71A225KE15
1	M1	AM2341P	P-Channel MOSFET; -40V V_{DS} ;130m Ω ; 15V V_{GS} ;3.2A	SOT-23	Analog Power	AM2341P
1	Q1	S8050	Transistor;25V;0.5A;	SOT-23	长电	S8050

- (2) Connect the jumper “EN” to “GND” and the “VCC” to “VREF33” with a shunt respectively!
- (3) Install a shunt on the jumper JP1.
- (4) Connect the jumper “MODE” and “VREF33” with a shunt.
- (5) Attach the positive and negative ends of the battery to the “BATT” and “GND” terminals respectively. If it’s a battery simulator, please preset the voltage to 3.8V (typical value) firstly.
- (6) Preset the DC power source to 5V. Then attach the DC output port and ground to the “USBIN” and “GND” terminals, respectively.

- (7) Turn on the DC power source. The charger enters the AC input mode that charges the battery with 2A current.
- (8) Remove the shunt between the jumper “MODE” and “VREF33”. The charger enters the USB input mode that limits the input current to 450mA.
- (9) Remove the shunt of JP1 and install it on the neighbor JP2. Verify the USB input current is limited to 900mA.
- (10) Remove the shunt between the “EN” and “GND” to disable charging.
- (11) Install the shunt between the “EN” and “GND” to enable charging.

Please see the datasheet of MP2611 for further detailed information.

NOTICE: The information in this document is subject to change without notice. Users should warrant and guarantee that third party Intellectual Property rights are not infringed upon when integrating MPS products into any application. MPS will not assume any legal responsibility for any said applications.