

## DESCRIPTION

The EV2610ER-00A is an evaluation board for the MP2610, a switching, high-performance 1~2 cell Li-Ion battery charger with built in internal power MOSFET.

MP2610 achieves up to 2A charge current over a wide input supply range. The charge current can be programmed by sensing the current through an accurate sense resistor.

MP2610 regulates the battery voltage and charge current using two control loops to realize high accuracy CC charge and CV charge.

Fault condition protection includes time out control, battery full terminated control, thermal protection, battery temperature monitoring and protection. The board also indicates AC adapter power good and charge status indications to the system.

## ELECTRICAL SPECIFICATION

Parameter	Symbol	Value	Units
Input Voltage	$V_{IN}$	5.5~24	V
Charge Current	$I_{CHG}$	2	A

## FEATURES

- Charge 1-, 2- cell Li-Ion Battery Packs
- Wide Operating Input Range
- Up to 2A Programmable Charging Current
- $\pm 0.75\%$   $V_{BATT}$  Accuracy
- Up to 90% Efficiency
- Fixed 1.1MHz Frequency
- Preconditioning for fully depleted batteries
- Charging Operation Indicator
- Input Supply and battery fault indicator
- Thermal Shutdown
- Battery Temperature Monitor and Protection

## APPLICATIONS

- Distributed Power Systems
- Chargers for 1-Cell or 2-Cell Li-Ion Batteries
- Pre-Regulator for Linear Regulators
- Smart Phones
- Net-book

"MPS" and "The Future of Analog IC Technology" are Registered Trademarks of Monolithic Power Systems, Inc.

## EV2610ER-00A EVALUATION BOARD



(L x W x H) 2.5" x 2.5" x 0.5"  
(6.35cm x 6.35cm x 1.2cm)

Board Number	MPS IC Number
EV2610ER-00A	MP2610ER

### 2 Cells Battery Charge Curve

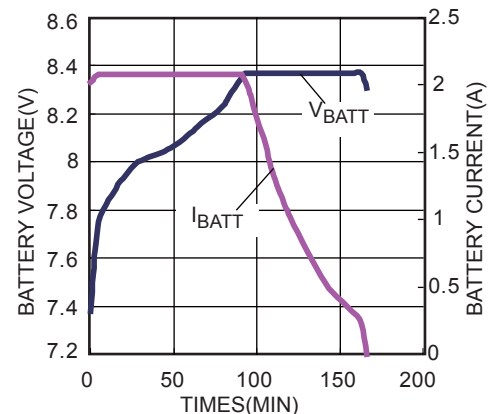

## EVALUATION BOARD SCHEMATIC

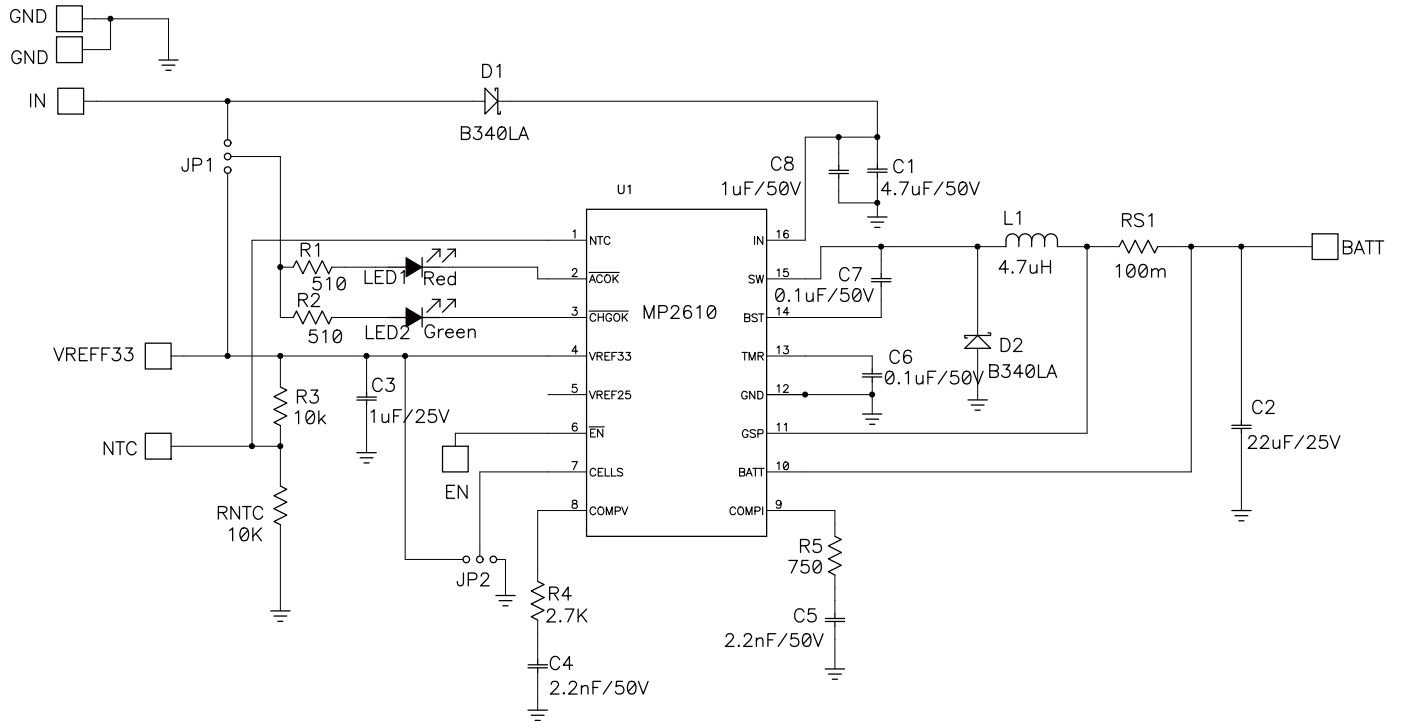

**EV2610ER-00A BILL OF MATERIALS**

Qty	Ref	Value	Description	Package	Manufacturer	Manufacturer P/N
1	C1	4.7uF	Ceramic Cap., 50V, X7R	1210	Murata	GRM32ER71H475KA88L
1	C2	22µF	Ceramic Cap., 25V, X5R	1210	Murata	GRM32ER61E226KE15L
1	C3	1uF	Ceramic Cap., 25V, X5R	0603	TDK	C1608X5R1E105K
2	C4,C5	2.2nF	Ceramic Cap., 50V, X7R	0603	TDK	C1608X7R1H222K
2	C6,C7	0.1uF	Ceramic Cap., 50V, X7R	0603	Murata	GRM188R71H104KA93D
1	C8	1uF	Ceramic Cap., 50V, X7R	0805	Murata	GRM21BR71H105KA12L
2	R1,R2	510Ω	Film Res., 5%	0805	LIZ	0805J510R
1	R3	10kΩ	Film Res., 1%	0603	Yageo	RC0603FR-0710KL
1	R4	2.7kΩ	Film Res., 5%	0603	LIZ	CR0603JA0272K
1	R5	750Ω	Film Res., 1%	0603	Yageo	RC0603FR-07750RL
1	RS1	100m	Film Res., 1%	2512	Vishay	WSL2512
1	NTC	10kΩ	Film Res., 1%	0603	Yageo	RC0603FR-0710KL
2	JP1, JP2		3-Pin Connector Header, 0.100"		Sullins	PTC03SAAN
1	LED1	Green	Led Green, Surface Mount	0805		
1	LED2	Red	Led Red, Surface Mount	0805		
1	D1,D2		Diode Schottky, 80V, 3A	SMA	Diodes Inc	B340LA-13F
1	L1	4.7uH	Inductor, 6A, 19.5mΩ	SMD	Würth	744311470
			Inductor, 3.8A, 38mΩ	SMD	Toko	DS84LC-B1015AS-4R7N
			Inductor, 5.2A, 18mΩ	SMD	muRata	LQH88PN4R7N38
			Inductor, 3.78A, 29.7mΩ	SMD	Cooper	DR73-4R7-R
1	U1		Switching Charger	QFN16	MPS	MP2610

### PRINTED CIRCUIT BOARD LAYOUT

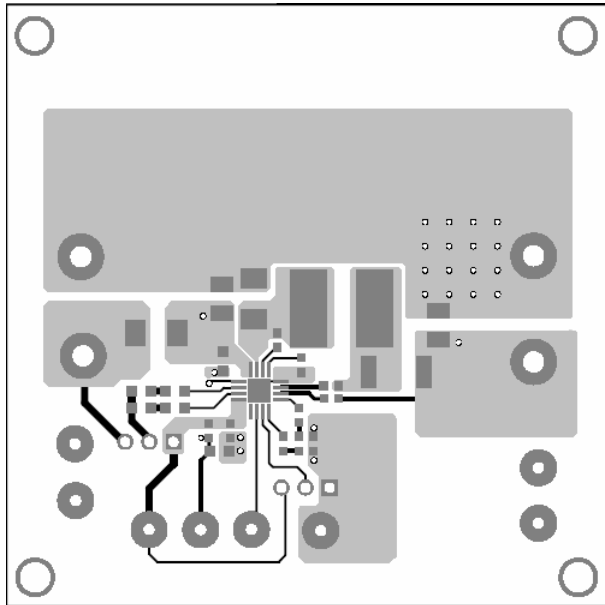

Figure 1—Top Layer

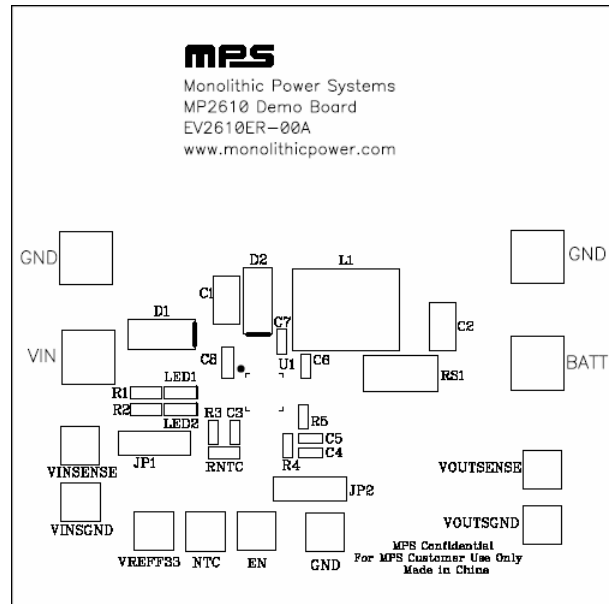

Figure 2—Top Silk Layer

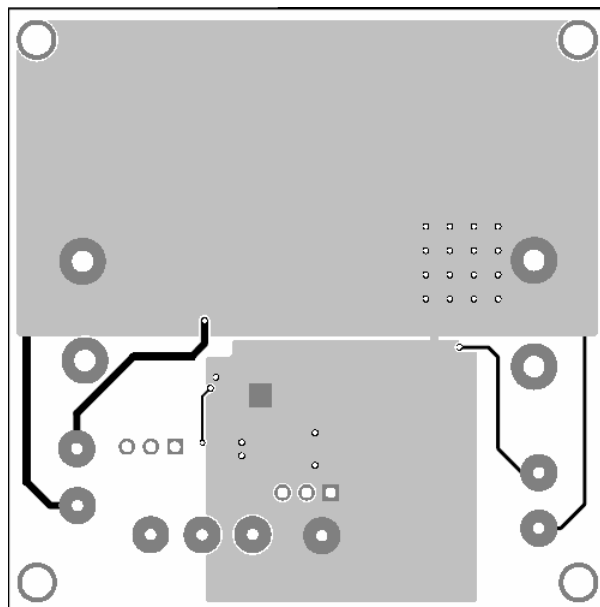

Figure 3—Bottom Layer

## QUICK START GUIDE

This board is MP2610 used as a standalone switching charger, and layout accommodates most commonly used capacitors.

The default output voltage on this board is preset to 4.2V for 1 cell Li-Ion battery. Change Cell pin connecting to VREF33, the output is regulated to 8.4V for 2 cell Li-Ion batteries.

The two LEDs are charger status indicators. When the input is OK for charging the battery load, LED1 will turn on. Otherwise it is off. When the charging operation is normal, the LED2 is on. And after the battery full or no battery connected, LED 2 will turn off.

1. Charge current setting:

For a standalone switching charger, the charge current can be programmed by the sense resistor RS1, the formula is as:

$$I_{\text{CHG}} (\text{A}) = \frac{200\text{mV}}{\text{RS1}(\text{m}\Omega)}$$

2. For a standalone switching charger, LED1 and LED2 is powered by VREF33.
3. Attached the input voltage ( $V_{\text{IN}}=19\text{V}$ ) and the input ground to the VIN and GND pins, respectively.
4. Attach the positive and negative ends of the battery to the BATT and GND pins, respectively.

**NOTICE:** The information in this document is subject to change without notice. Please contact MPS for current specifications. Users should warrant and guarantee that third party Intellectual Property rights are not infringed upon when integrating MPS products into any application. MPS will not assume any legal responsibility for any said applications.