



# EVQ1922-V-00A

## 100V, Half-Bridge Pre-Driver with Internal Current-Sense Amplifier Evaluation Board, AEC-Q100 Qualified

### DESCRIPTION

The EVQ1922-V-00A is an evaluation board designed for the MPQ1922, a half-bridge gate driver that can be used in motor driver and other power control applications. The device drives two N-channel power MOSFETs in a half-bridge configuration, and operates on power supplies up to 100V.

To prevent shoot-through in the output MOSFETs, the MPQ1922 generates an adaptive dead time by monitoring the gate

driver output voltages. This ensures that each MOSFET gate has been fully discharged before the opposing MOSFET turns on. A longer dead time can be generated by providing a delay between the INH and INL input signals.

The EVQ1922-V-00A is confirmed for a buck converter. The INH and INL signals are independent of one another.

The MPQ1922 is available in a QFN-22 (4mmx5mm) package.

### PERFORMANCE SUMMARY

Parameters	Conditions	Value
Input voltage ( $V_{IN}$ ) range		5V to 100V
Gate drive supply voltage ( $V_G$ ) range		5V to 15V
Logic power supply voltage ( $V_{CC}$ )		3.3V or 5V
CSEN voltage ( $V_{CSEN}$ )		3.3V or 5V

### EVALUATION BOARD

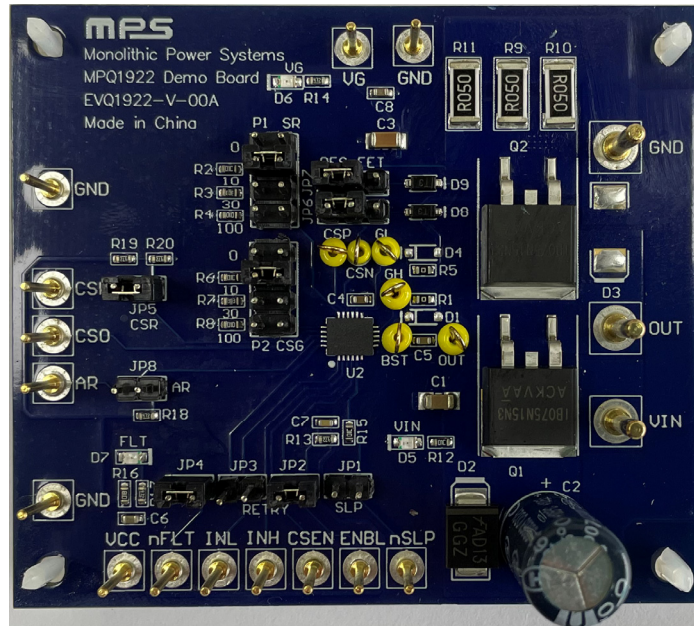

(LxW) 7.5cmx6.5cm

Board Number	MPS IC Number
EVQ1922-V-00A	MPQ1922GVE-AEC1

## QUICK START GUIDE

The EVQ1922-V-00A is configured for a buck converter. Follow the steps below to evaluate the device.

1. Preset the gate drive power supply ( $V_G$ ) between 5V and 15V (12V is recommended).
2. Preset the input power supply ( $V_{IN}$ ) between  $V_G$  and 100V.
3. Connect the gate driver power supply terminals to:
  - a. Positive (+):  $V_G$
  - b. Negative (-): GND
4. Connect the input power supply terminals to:
  - a. Positive (+):  $V_{IN}$
  - b. Negative (-): GND
5. Connect the logic power supply ( $V_{CC}$ ) terminals to:
  - a. Positive (+):  $V_{CC}$
  - b. Negative (-): GND
6. Connect the load to:
  - a. Positive (+): OUT
  - b. Negative (-): GND
7. Set the INH signal settings:
  - a. Logic high: 3.3V or 5V
  - b. Logic low: 0V
  - c. The recommended switching frequency is 20kHz.  
Set the INL control signal to the reverse INH signal, with a sufficient dead time.
8. Set the current-sense gain using the CSG resistor.
9. Set the output rising/falling edge slew rate using the SR resistor.
10. Turn on the input power supply ( $V_{IN}$ ) first, then turn on the gate driver power supply ( $V_G$ ).
11. To turn off the board, follow the steps below:
  - a. Turn off the load.
  - b. Turn off the gate driver power supply ( $V_G$ ).
  - c. Turn off the input power supply ( $V_{IN}$ ).

# EVALUATION BOARD SCHEMATIC

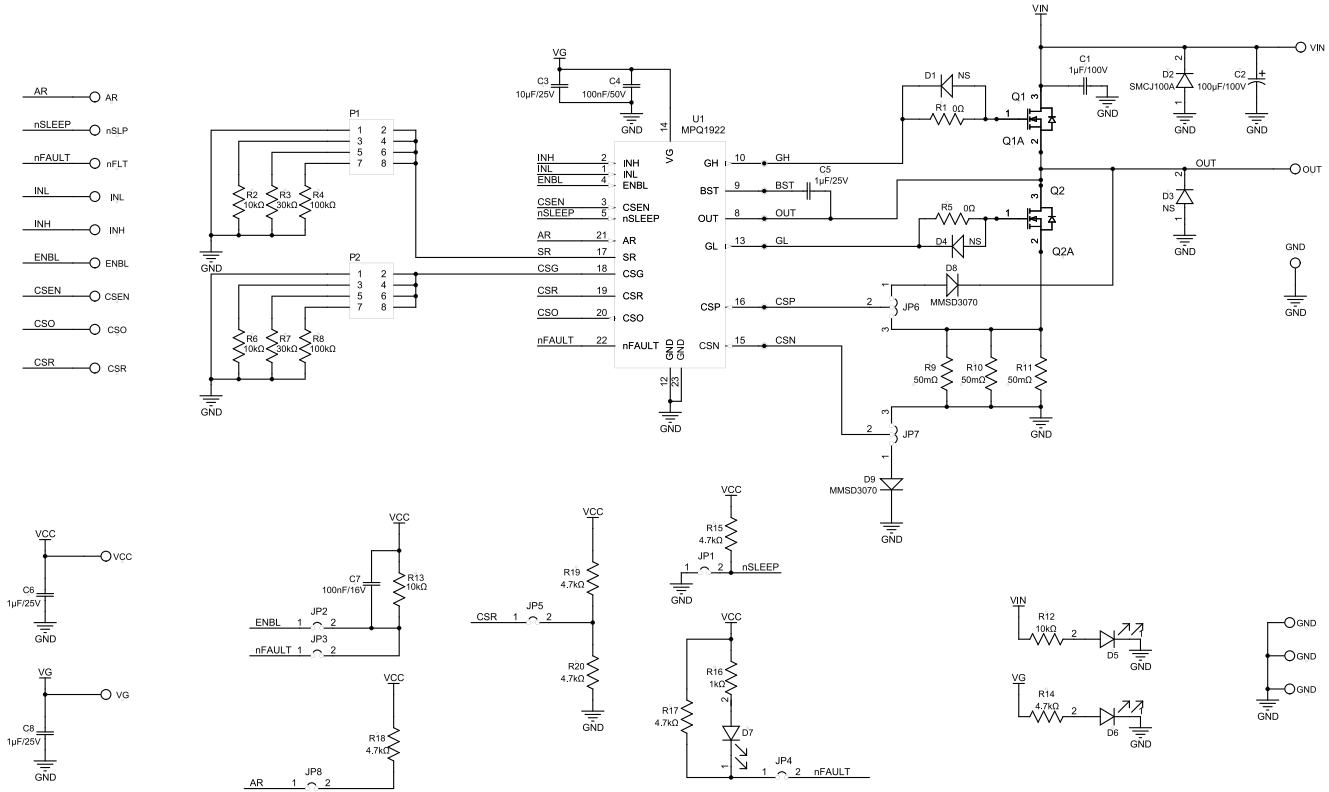

Figure 1: Evaluation Board Schematic

**EVQ1922-V-00A BILL OF MATERIALS**

Qty	Ref	Value	Description	Package	Manufacturer	Manufacturer PN
1	C1	1 $\mu$ F	Ceramic capacitor, 100V, X7R	1206	Murata	GRM31CR72A105KA01L
1	C2	100 $\mu$ F	Electrolytic capacitor, 100V	DIP	Jianghai	CD263-100V100
1	C3	10 $\mu$ F	Ceramic capacitor, 25V, X7R	1206	Murata	GRM31CR71E106KA12
1	C4	100nF	Ceramic capacitor, 50V, X7R	0603	Murata	GCJ188R71H104KA12D
3	C5, C6, C8	1 $\mu$ F	Ceramic capacitor, 25V, X5R	0603	Wurth	885012106022
1	C7	100nF	Ceramic capacitor, 16V, X7R	0603	Murata	GRM188R71C104KA01D
2	R1, R5	0 $\Omega$	Film resistor, 1%	0603	Yageo	RC0603FR-070RL
4	R2, R6, R12, R13	10k $\Omega$	Film resistor, 1%	0603	Yageo	RC0603FR-0710KL
2	R3, R7	30k $\Omega$	Film resistor, 1%	0603	Yageo	RC0603FR-0730KL
2	R4, R8	100k $\Omega$	Film resistor, 1%	0603	Yageo	RC0603FR-07100KL
3	R9, R10, R11	50m $\Omega$	Film resistor, 1%	2512	Yageo	RL2512FK-070R05L
6	R14, R15, R17, R18, R19, R20	4.7k $\Omega$	Film resistor, 1%	0603	Yageo	RC0603FR-074K7L
1	R16	1k $\Omega$	Film resistor, 1%	0603	Yageo	RC0603FR-071KL
3	D1, D3, D4	NS				
1	D2	100V, 9.3A	TVS	DO-214AB	Fairchild	SMCJ100A
3	D5, D6, D7	Red	LED	0805	Baihong	BL-HUE35A-AV-TRB
2	D8, D9	200V, 0.2A	Small signal diode	SOD-123	Fairchild	MMSD3070
2	Q1, Q2	150V, 90A	N-channel MOSFET, 150V, 90A, R <sub>ON</sub> = 12m $\Omega$ , Q <sub>G</sub> = 55nC	TO-263	Analog power	AMIB075N15N3-T1-PF
2	Q1A, Q2A	NS				

**EVQ1922-V-00A BILL OF MATERIALS (continued)**

Qty	Ref	Value	Description	Package	Manufacturer	Manufacturer PN
1	U1	MPQ1922	100V, half-bridge pre-driver	QFN-22 (4mmx5mm)	MPS	MPQ1922GVE-AEC1
6	JP1, JP2, JP3, JP4, JP5, JP8	2 bits/ 2.54mm	Connector	DIP	Any	
7	JP2, JP4, JP5, JP6(RES), JP7(RES), P1(second row), P2(second row)	2.54mm	Short jumper	DIP	Any	
2	JP6, JP7	3 bits/ 2.54mm	Connector	DIP	Any	
2	P1, P2	4 bits/ 2.54mm	Double row connector	DIP	Any	
3	VIN, OUT, GND	$\Phi = 2\text{mm}$	Connector	DIP	Any	
14	VG, CSR, CSO, AR, VCC, nFLT, INL, INH, CSEN, ENBL, nSLP, GND, GND, GND	$\Phi = 1\text{mm}$	Connector	DIP	Any	
6	CSP, CSN, GL, GH, BST, OUT	Yellow	Test point	DIP	Any	

### PCB LAYOUT

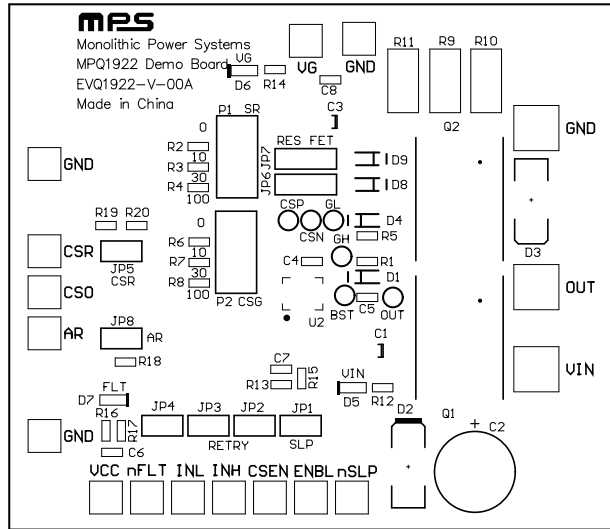

Figure 2: Top Silk

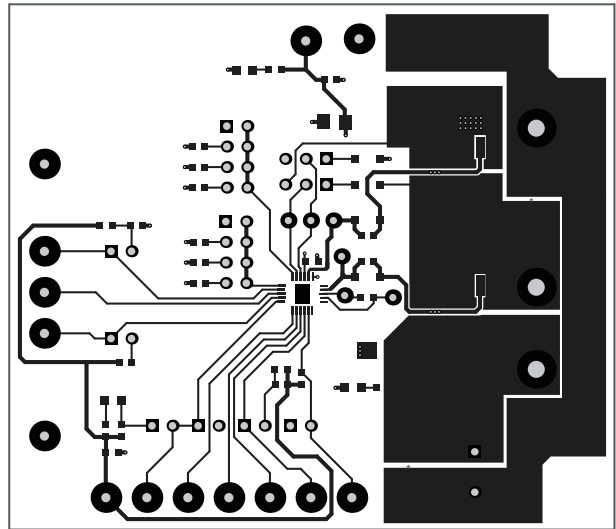

Figure 3: Top Layer

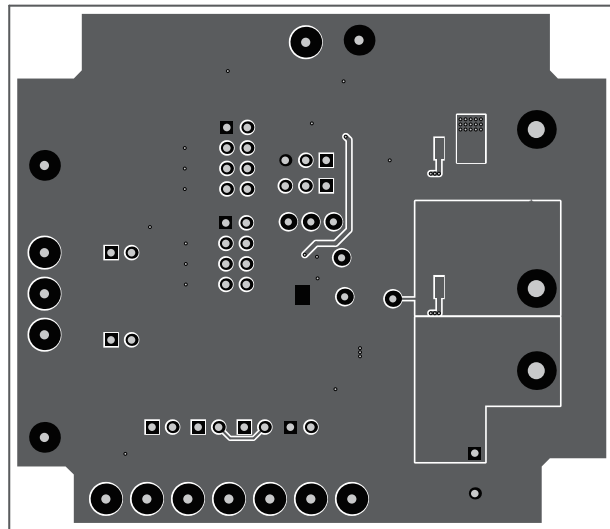

Figure 4: Bottom Layer

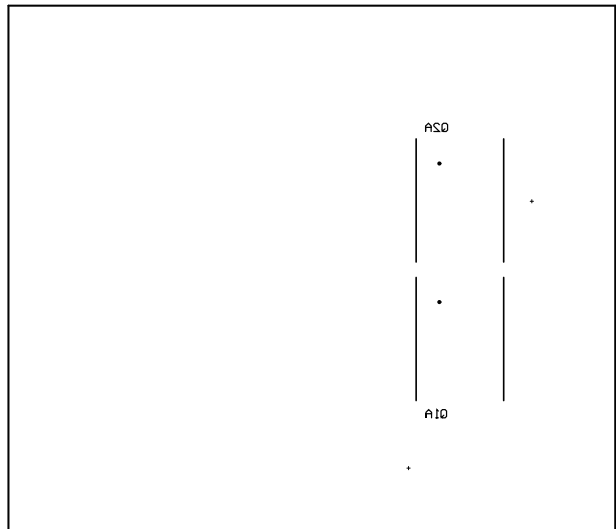

Figure 5: Bottom Silk



## REVISION HISTORY

Revision #	Revision Date	Description	Pages Updated
1.0	10/08/2021	Initial Release	-

**Notice:** The information in this document is subject to change without notice. Please contact MPS for current specifications. Users should warrant and guarantee that third-party Intellectual Property rights are not infringed upon when integrating MPS products into any application. MPS will not assume any legal responsibility for any said applications.