

**Product Specification**

---

# NHD-2.7-12864WDY3

## Graphic OLED Display Module

<b>NHD-</b>	Newhaven Display
<b>2.7-</b>	2.7" Diagonal Size
<b>12864-</b>	128x64 Pixel Resolution
<b>WD-</b>	Model
<b>Y-</b>	Emitting Color: Yellow
<b>3-</b>	3.3V Power Supply

## Table of Contents

Document Revision History.....	2
Mechanical Drawing.....	3
Pin Description.....	4
Interface Selection.....	5
On-Board Jumper Options.....	5
Electrical Characteristics.....	6
Optical Characteristics.....	7
Controller Information.....	7
Table of Commands.....	8
Timing Characteristics – OLED.....	11
Example Software Routines.....	15
Quality Information.....	16

---

## Additional Resources

- **Support Forum:** <https://support.newhavendisplay.com/hc/en-us/community/topics>
- **GitHub:** <https://github.com/newhavendisplay>
- **Example Code:** <https://support.newhavendisplay.com/hc/en-us/categories/4409527834135-Example-Code/>
- **Knowledge Center:** [https://www.newhavendisplay.com/knowledge\\_center.html](https://www.newhavendisplay.com/knowledge_center.html)
- **Quality Center:** [https://www.newhavendisplay.com/quality\\_center.html](https://www.newhavendisplay.com/quality_center.html)
- **Precautions for using LCDs/LCMs:** <https://www.newhavendisplay.com/specs/precautions.pdf>
- **Warranty / Terms & Conditions:** <https://www.newhavendisplay.com/terms.html>

## Document Revision History

Revision	Date	Description	Changed By
-	06/02/2017	Initial Release	ML
1	07/25/2017	Update Storage Temperature Range	ML
2	06/21/2019	Updated 6800 Mode Control and Added Timing Diagrams	TM
3	03/30/2020	Updated Brightness	SB
4	05/12/2020	Included Additional Dimensions on Mechanical Drawing	AS
5	02/04/2021	Bezel Redesign; Updated 2D Mechanical Drawing	AS
6	02/26/2020	Rectified Error in MPU Pin Assignment Summary	AS
7	08/17/2023	Minimum Supply Voltage Updated from 2.8V to 3.0V	KL

# Mechanical Drawing

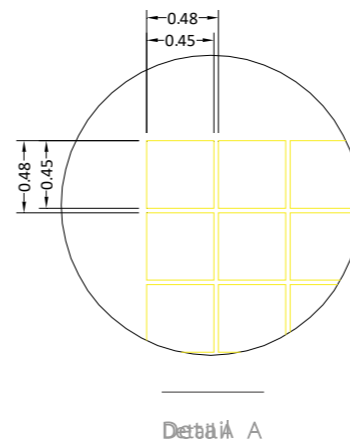
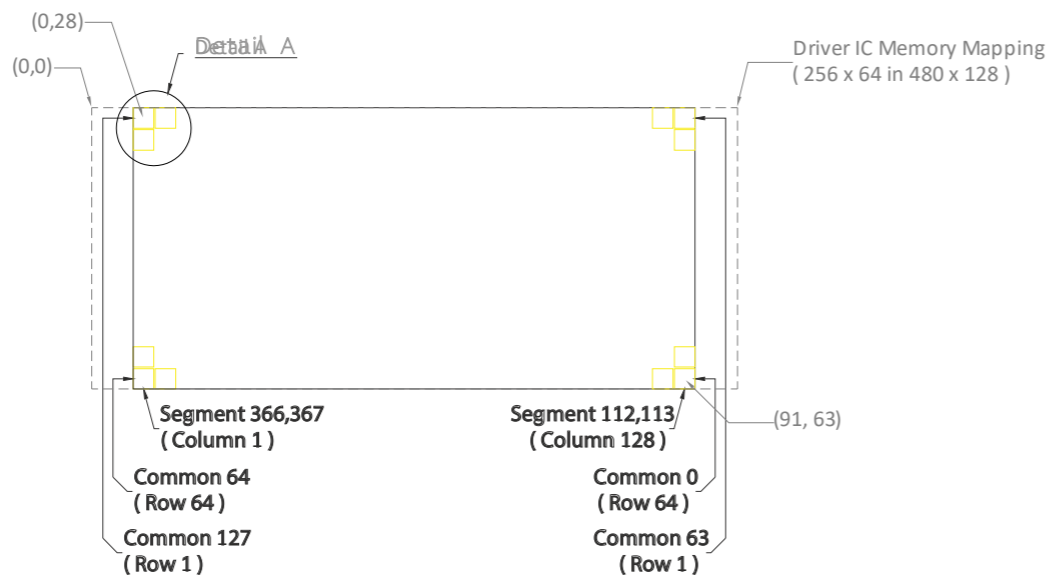
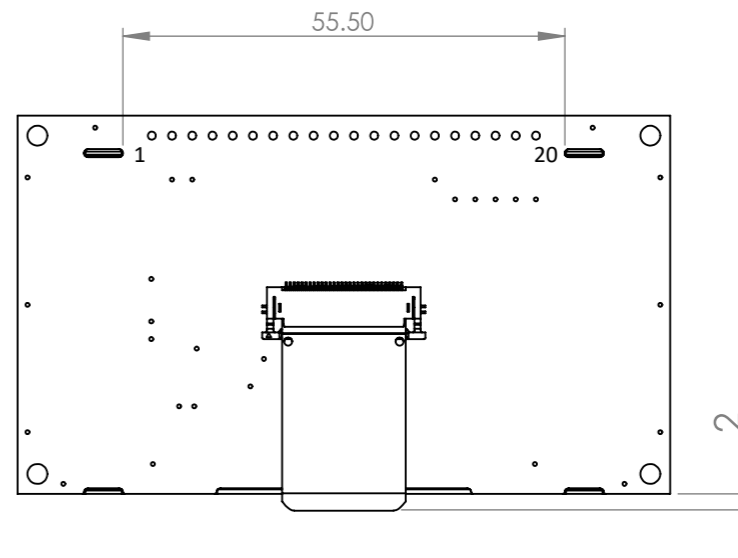
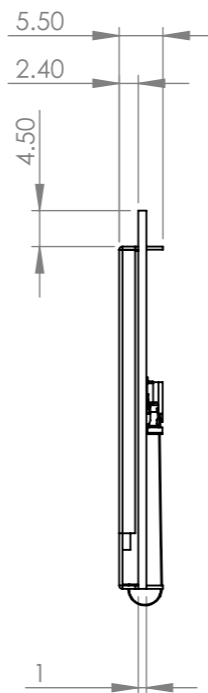
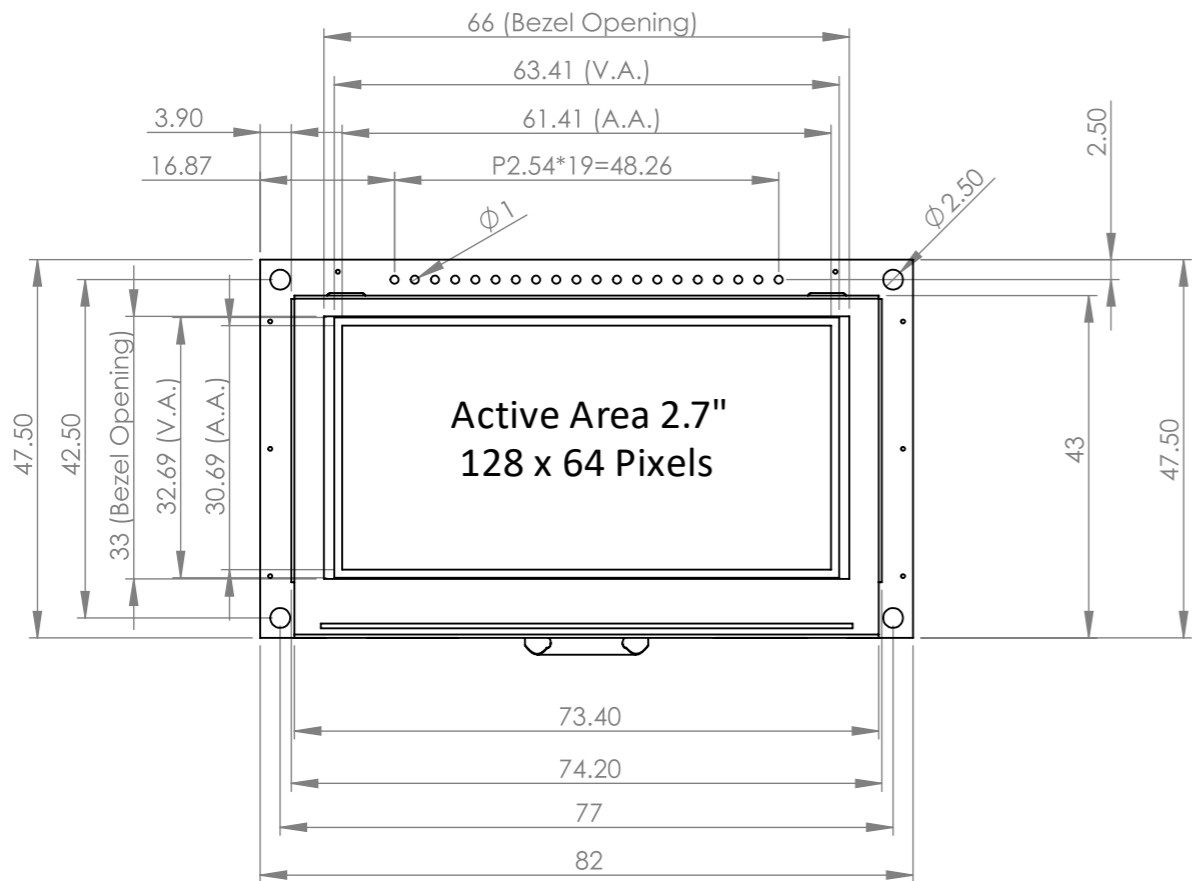

Pin No.	Symbol
1	Vss
2	Vdd
3	NC (BC_VDD)
4	D/C
5	R/W
6	E
7	DB0
8	DB1
9	DB2
10	DB3
11	DB4
12	DB5
13	DB6
14	DB7
15	N.C. (Vcc)
16	/RES
17	/CS
18	/SHDN (N.C.)
19	BS1
20	BS0

Product Description: 2.7" 128x64 Graphic OLED

1. Driver IC: SSD1322
2. Interface: 8-bit 6800/8080 Parallel, 3/4-wire SPI
3. Power Requirement: 3.3V OLED
4. Optical Features: Yellow Color, Anti-Glare, Full View
5. Recommended Pin Header: 1x20pin 2.54mm pitch

<b>Standard Tolerance:</b> (Unless otherwise specified)  Linear: ±0.3mm		
	Drawing/Part Number: <b>NHD-2.7-12864WDY3</b>	Revision: -
<b>Unless otherwise specified:</b> • Dimensions are in Millimeters • Third Angle Projection	Drawn By: K. Lewis	Approved By: K. Lewis
	Drawn Date: 08/17/2023	Approved Date: 08/17/2023
This drawing is solely the property of Newhaven Display International, Inc. The information it contains is not to be disclosed, reproduced or copied in whole or part without written approval from Newhaven Display.		

## Pin Description

### Parallel Interface:

Pin No.	Symbol	External Connection	Function Description
1	V <sub>SS</sub>	Power Supply	Ground
2	V <sub>DD</sub>	Power Supply	Supply Voltage for OLED module
3	NC (BC_V <sub>DD</sub> )	-	No Connect by default. Can be configured to power the boost converter independently. (refer to On-Board Jumper Options section)
4	D/C	MPU	Data/Command select signal, D/C=0: Command; D/C=1: Data
5	R/W /WR	MPU	<b>6800 mode:</b> Read/Write select signal, R/W=1: Read, R/W=0: Write <b>8080 mode:</b> Active LOW Write signal
6	E /RD	MPU	<b>6800 mode:</b> Operation Enable signal. Falling edge triggered. <b>8080 mode:</b> Active LOW Read signal
7-14	DB0 – DB7	MPU	8-bit bi-directional Data Bus
15	NC (V <sub>CC</sub> )	-	No Connect by default. Can be configured to power V <sub>CC</sub> independently. (refer to On-Board Jumper Options section)
16	/RES	MPU	Active LOW Reset signal
17	/CS	MPU	Active LOW Chip Select signal
18	/SHDN	MPU	Active LOW Shutdown signal for boost converter (internally pulled HIGH).
19	BS1	MPU	MPU Interface select signal
20	BS0	MPU	MPU Interface select signal

### Serial Interface:

Pin No.	Symbol	External Connection	Function Description
1	V <sub>SS</sub>	Power Supply	Ground
2	V <sub>DD</sub>	Power Supply	Supply Voltage for OLED module
3	NC (BC_V <sub>DD</sub> )	-	No Connect by default. Can be configured to power the boost converter independently. (refer to On-Board Jumper Options section)
4	D/C	MPU	Data/Command select signal, D/C=0: Command; D/C=1: Data Tie LOW for 3-wire SPI
5-6	V <sub>SS</sub>	Power Supply	Ground
7	SCLK	MPU	Serial Clock signal
8	SDIN	MPU	Serial Data Input signal
9	NC	-	No Connect
10-14	V <sub>SS</sub>	Power Supply	Ground
15	NC (V <sub>CC</sub> )	-	No Connect by default. Can be configured to power V <sub>CC</sub> independently. (refer to On-Board Jumper Options section)
16	/RES	MPU	Active LOW Reset signal
17	/CS	MPU	Active LOW Chip Select signal
18	/SHDN	MPU	Active LOW Shutdown signal for boost converter (internally pulled HIGH).
19	BS1	MPU	MPU Interface select signal
20	BS0	MPU	MPU Interface select signal

# Interface Selection

## MPU Interface Pin Selections

Pin Name	6800 Parallel 8-bit interface	8080 Parallel 8-bit interface	3-wire Serial Interface	4-wire Serial Interface
BS1	1	1	0	0
BS0	1	0	1	0

## MPU Interface Pin Assignment Summary

Bus Interface	Data/Command Interface								Control Signals				
	D7	D6	D5	D4	D3	D2	D1	D0	E	R/W	/CS	D/C	/RES
8-bit 6800	D[7:0]								E	R/W	/CS	D/C	/RES
8-bit 8080	D[7:0]								/RD	/WR	/CS	D/C	/RES
3-wire SPI	Tie LOW					NC	SDIN	SCLK	Tie LOW		/CS	Tie LOW	/RES
4-wire SPI	Tie LOW					NC	SDIN	SCLK	Tie LOW		/CS	D/C	/RES

# On-Board Jumper Options

## Default Jumper Setting

R4	R5	R7	Description
<b>Close</b>	Open	Open	OLED controller + Boost converter + OLED panel are powered from V <sub>DD</sub> (pin #2). This allows the full module to be powered by a single low-voltage supply.

## Jumper Option #1 - Independent Supply Voltage for Boost Converter (BC\_VDD)

R4	R5	R7	Description
Open	<b>Close</b>	Open	Boost converter + OLED panel are powered from BC_V <sub>DD</sub> (pin #3). OLED controller is still powered from V <sub>DD</sub> (pin #2). This allows for increased efficiency through the boost converter by allowing a higher supply voltage at its input, BC_V <sub>DD</sub> (pin #3).

## Jumper Option #2 – External Supply Voltage for OLED Panel (VCC)

R4	R5	R7	Description
Open	Open	<b>Close</b>	OLED panel is powered from V <sub>CC</sub> (pin #15) – boost converter is not used. OLED controller is still powered from V <sub>DD</sub> (pin #2). This allows for maximum module efficiency, and drastically reduced total current consumption.

**Default Jumper Setting**

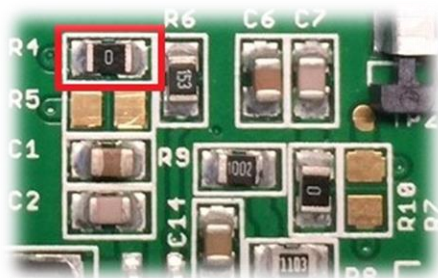

**Jumper Option #1**

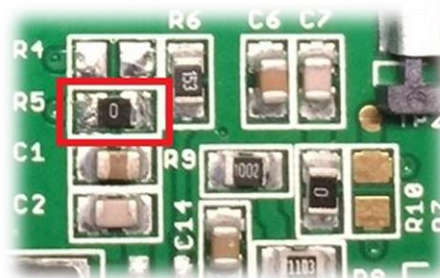

**Jumper Option #2**

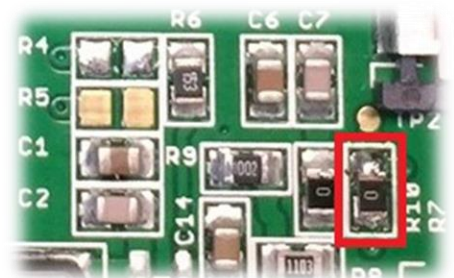

For detailed electrical information on each jumper option, please see the Electrical Characteristics table below.

## Electrical Characteristics

Item	Symbol	Condition	Min.	Typ.	Max.	Unit
Operating Temperature Range	T <sub>OP</sub>	Absolute Max	-40	-	+85	°C
Storage Temperature Range	T <sub>ST</sub>	Absolute Max	-40	-	+85	°C
<b>Default Jumper Setting</b>						
<b>Supply Voltage for Module</b>	<b>V<sub>DD</sub></b>	-	<b>3.0</b>	<b>3.3</b>	<b>3.5</b>	<b>V</b>
<b>Supply Current for Module</b>	<b>I<sub>DD</sub></b>	<b>V<sub>DD</sub>=3.3V, 100% ON</b>	-	<b>330</b>	<b>360</b>	<b>mA</b>
Jumper Option #1						
Supply Voltage for Module	V <sub>DD</sub>	-	3.0	3.3	3.5	V
Supply Current for Module	I <sub>DD</sub>	V <sub>DD</sub> =3.3V	-	180	295	μA
Supply Voltage for Boost Converter	BC_V <sub>DD</sub>	-	3.0	5.0	12	V
Supply Current for Boost Converter	I <sub>DD_BC</sub>	BC_V <sub>DD</sub> =5.0V, 100% ON	-	190	205	mA
Supply Current for Boost Converter	I <sub>DD_BC</sub>	BC_V <sub>DD</sub> =12.0V, 100% ON	-	70	80	mA
Jumper Option #2						
Supply Voltage for Module	V <sub>DD</sub>	-	3.0	3.3	3.5	V
Supply Current for Module	I <sub>DD</sub>	V <sub>DD</sub> =3.3V	-	180	300	μA
Supply Voltage for OLED Panel	V <sub>CC</sub>	-	14.5	15	15.5	V
Supply Current for OLED Panel	I <sub>CC</sub>	V <sub>CC</sub> =15V, 100% ON	-	60	70	mA
Sleep Mode Current	I <sub>DD_SLEEP</sub>	-	-	25	120	μA
"H" Level input	V <sub>IH</sub>	-	0.8 * V <sub>DD</sub>	-	V <sub>DD</sub>	V
"L" Level input	V <sub>IL</sub>	-	V <sub>SS</sub>	-	0.2 * V <sub>DD</sub>	V
"H" Level output	V <sub>OH</sub>	-	0.9 * V <sub>DD</sub>	-	V <sub>DD</sub>	V
"L" Level output	V <sub>OL</sub>	-	V <sub>SS</sub>	-	0.1 * V <sub>DD</sub>	V

**Note:** The electrical characteristics shown above for Jumper Option #1 and Jumper Option #2 apply only when the on-board jumpers are configured accordingly. By default, only Default Jumper Setting supply voltage and current (in bold) need to be considered. For details, see On-Board Jumper Options section on previous page.

## Optical Characteristics

Item		Symbol	Condition	Min.	Typ.	Max.	Unit
Optimal Viewing Angles	Top	$\phi Y+$	-	-	85	-	°
	Bottom	$\phi Y-$		-	85	-	°
	Left	$\theta X-$		-	85	-	°
	Right	$\theta X+$		-	85	-	°
Contrast Ratio		$C_R$	-	>10,000:1	-	-	-
Response Time	Rise	$T_R$	-	-	10	-	$\mu s$
	Fall	$T_F$	-	-	10	-	$\mu s$
Brightness		$L_V$	50% Checkerboard	60	80	-	$cd/m^2$
Lifetime		-	$T_{OP}=25^\circ C, L_V=80cd/m^2$	100,000	-	-	hrs
		-	$T_{OP}=25^\circ C, L_V=60cd/m^2$	150,000	-	-	hrs

**Note:** Lifetime at typical temperature is based on accelerated high-temperature operation. Lifetime is tested at average 50% pixels on and is rated as Hours until **Half-Brightness**. To extend the life of the display, lower values may be used for the contrast setting registers – see below table of commands for details.

## Controller Information

Built-in SSD1322 Controller: <https://support.newhavendisplay.com/hc/en-us/articles/4414477846679-SSD1322>



## Table of Commands

Instruction	Code										Description	RESET value
	D/C	HEX	DB7	DB6	DB5	DB4	DB3	DB2	DB1	DB0		
Enable Grayscale Table	0	<b>00</b>	<b>0</b>	<b>0</b>	<b>0</b>	<b>0</b>	<b>0</b>	<b>0</b>	<b>0</b>	<b>0</b>	Enable the Grayscale table settings. (see command 0xB8)	
Set Column Address	0	<b>15</b>	<b>0</b>	<b>0</b>	<b>0</b>	<b>1</b>	<b>0</b>	<b>1</b>	<b>0</b>	<b>1</b>	Set column start and end address A[6:0]: Column start address. Range: 0-119d B[6:0]: Column end address. Range: 0-119d	0 119d
	1	<b>A[6:0]</b>	*	<b>A6</b>	<b>A5</b>	<b>A4</b>	<b>A3</b>	<b>A2</b>	<b>A1</b>	<b>A0</b>		
	1	<b>B[6:0]</b>	*	<b>B6</b>	<b>B5</b>	<b>B4</b>	<b>B3</b>	<b>B2</b>	<b>B1</b>	<b>B0</b>		
Write RAM Command	0	<b>5C</b>	<b>0</b>	<b>1</b>	<b>0</b>	<b>1</b>	<b>1</b>	<b>1</b>	<b>0</b>	<b>0</b>	Enable MCU to write Data into RAM	
Read RAM Command	0	<b>5D</b>	<b>0</b>	<b>1</b>	<b>0</b>	<b>1</b>	<b>1</b>	<b>1</b>	<b>0</b>	<b>1</b>	Enable MCU to read Data from RAM	
Set Row Address	0	<b>75</b>	<b>0</b>	<b>1</b>	<b>1</b>	<b>1</b>	<b>0</b>	<b>1</b>	<b>0</b>	<b>1</b>	Set row start and end address A[6:0]: Row start address. Range: 0-127d B[6:0]: Row end address. Range: 0-127d	0 127d
	1	<b>A[6:0]</b>	*	<b>A6</b>	<b>A5</b>	<b>A4</b>	<b>A3</b>	<b>A2</b>	<b>A1</b>	<b>A0</b>		
	1	<b>B[6:0]</b>	*	<b>B6</b>	<b>B5</b>	<b>B4</b>	<b>B3</b>	<b>B2</b>	<b>B1</b>	<b>B0</b>		
Set Re-map	0	<b>A0</b>	<b>1</b>	<b>0</b>	<b>1</b>	<b>0</b>	<b>0</b>	<b>0</b>	<b>0</b>	<b>0</b>	A[0] = 0; Horizontal Address Increment A[0] = 1; Vertical Address Increment A[1] = 0; Disable Column Address remap A[1] = 1; Enable Column Address remap A[2] = 0; Disable Nibble remap A[2] = 1; Enable Nibble remap A[4] = 0; Scan from COM0 to COM[N-1] A[4] = 1; Scan from COM[N-1] to COM0 A[5] = 0; Disable COM split Odd/Even A[5] = 1; Enable COM split Odd/Even B[4] = 0; Disable Dual COM mode B[4] = 1; Enable Dual COM mode Note: A[5] must be 0 if B[4] is 1.	0 0 0 0 0 0
	1	<b>A[5:0]</b>	<b>0</b>	<b>0</b>	<b>A5</b>	<b>A4</b>	<b>0</b>	<b>A2</b>	<b>A1</b>	<b>A0</b>		
	1	<b>B[4]</b>	*	*	<b>0</b>	<b>B4</b>	<b>0</b>	<b>0</b>	<b>0</b>	<b>1</b>		
Set Display Start Line	0	<b>A1</b>	<b>1</b>	<b>0</b>	<b>1</b>	<b>0</b>	<b>0</b>	<b>0</b>	<b>0</b>	<b>1</b>	Set display RAM display start line register from 0-127.	0
	1	<b>A[6:0]</b>	*	<b>A6</b>	<b>A5</b>	<b>A4</b>	<b>A3</b>	<b>A2</b>	<b>A1</b>	<b>A0</b>		
Set Display Offset	0	<b>A2</b>	<b>1</b>	<b>0</b>	<b>1</b>	<b>0</b>	<b>0</b>	<b>0</b>	<b>1</b>	<b>0</b>	Set vertical shift by COM from 0~127.	0
	1	<b>A[6:0]</b>	*	<b>A6</b>	<b>A5</b>	<b>A4</b>	<b>A3</b>	<b>A2</b>	<b>A1</b>	<b>A0</b>		
Display Mode	0	<b>A4~A7</b>	<b>1</b>	<b>0</b>	<b>1</b>	<b>0</b>	<b>0</b>	<b>X2</b>	<b>X1</b>	<b>X0</b>	0xA4 = Entire display OFF 0xA5 = Entire display ON, all pixels Grayscale level 15 0xA6 = Normal display 0xA7 = Inverse display	0xA6
Enable Partial Display	0	<b>A8</b>	<b>1</b>	<b>0</b>	<b>1</b>	<b>0</b>	<b>1</b>	<b>0</b>	<b>0</b>	<b>0</b>	Turns ON partial mode. A[6:0] = Address of start row B[6:0] = Address of end row (B[6:0] > A[6:0])	
	1	<b>A[6:0]</b>	<b>0</b>	<b>A6</b>	<b>A5</b>	<b>A4</b>	<b>A3</b>	<b>A2</b>	<b>A1</b>	<b>A0</b>		
	1	<b>B[6:0]</b>	<b>0</b>	<b>B6</b>	<b>B5</b>	<b>B4</b>	<b>B3</b>	<b>B2</b>	<b>B1</b>	<b>B0</b>		
Exit Partial Display	0	<b>A9</b>	<b>1</b>	<b>0</b>	<b>1</b>	<b>0</b>	<b>1</b>	<b>0</b>	<b>0</b>	<b>1</b>	Exit Partial Display mode	
Function Selection	0	<b>AB</b>	<b>1</b>	<b>0</b>	<b>1</b>	<b>0</b>	<b>1</b>	<b>0</b>	<b>1</b>	<b>1</b>	A[0] = 0; External VDD A[0] = 1; Internal VDD regulator	1



											The setting must be followed by command 0x00.		
Select Default Linear Gray Scale Table	0 1	<b>B9</b>	<b>1</b>	<b>0</b>	<b>1</b>	<b>1</b>	<b>1</b>	<b>1</b>	<b>0</b>	<b>0</b>	<b>1</b>	Sets Linear Grayscale table GS0 pulse width = 0 GS0 pulse width = 0 GS0 pulse width = 8 GS0 pulse width = 16 . . . GS0 pulse width = 104 GS0 pulse width = 112	
Set Pre-charge Voltage	0 1	<b>BB</b> <b>A[4:0]</b>	<b>1</b> *	<b>0</b> *	<b>1</b> *	<b>1</b> <b>A4</b>	<b>1</b> <b>A3</b>	<b>0</b> <b>A2</b>	<b>1</b> <b>A1</b>	<b>1</b> <b>A0</b>	Set precharge voltage level. A[4:0] = 0x00; 0.20*VCC . . A[4:0] = 0x3E; 0.60*VCC	0x17	
Set VCOMH Voltage	0 1	<b>BE</b> <b>A[3:0]</b>	<b>1</b> *	<b>0</b> *	<b>1</b> *	<b>1</b> *	<b>1</b> <b>A3</b>	<b>1</b> <b>A2</b>	<b>1</b> <b>A1</b>	<b>0</b> <b>A0</b>	Sets the VCOMH voltage level A[3:0] = 0x00; 0.72*VCC . . A[3:0] = 0x04; 0.8*VCC . . A[3:0] = 0x07; 0.86*VCC	0x04	
Set Contrast Control	0 1	<b>C1</b> <b>A[7:0]</b>	<b>1</b> <b>A7</b>	<b>1</b> <b>A6</b>	<b>0</b> <b>A5</b>	<b>0</b> <b>A4</b>	<b>0</b> <b>A3</b>	<b>0</b> <b>A2</b>	<b>0</b> <b>A1</b>	<b>1</b> <b>A0</b>	Double byte command to select 1 out of 256 contrast steps. Contrast increases as the value increases.	0x7F	
Master Contrast Control	0 1	<b>C7</b> <b>A[3:0]</b>	<b>1</b> *	<b>1</b> *	<b>0</b> *	<b>0</b> *	<b>0</b> <b>A3</b>	<b>1</b> <b>A2</b>	<b>1</b> <b>A1</b>	<b>1</b> <b>A0</b>	A[3:0] = 0x00; Reduce output for all colors to 1/16 A[3:0] = 0x01; Reduce output for all colors to 2/16 . . A[3:0] = 0x0E; Reduce output for all colors to 15/16 A[3:0] = 0x0F; no change	0x0f	
Set Multiplex Ratio	0 1	<b>CA</b> <b>A[6:0]</b>	<b>1</b> *	<b>1</b> <b>A6</b>	<b>0</b> <b>A5</b>	<b>0</b> <b>A4</b>	<b>1</b> <b>A3</b>	<b>0</b> <b>A2</b>	<b>1</b> <b>A1</b>	<b>0</b> <b>A0</b>	Set MUX ratio to N+1 MUX N=A[6:0]; from 16MUX to 128MUX (0 to 14 are invalid)	127d	
Set Command Lock	0 1	<b>FD</b> <b>A[2]</b>	<b>1</b> <b>0</b>	<b>1</b> <b>0</b>	<b>1</b> <b>0</b>	<b>1</b> <b>1</b>	<b>1</b> <b>0</b>	<b>1</b> <b>A2</b>	<b>0</b> <b>1</b>	<b>1</b> <b>0</b>	A[2] = 0; Unlock OLED to enable commands A[2] = 1; Lock OLED from entering commands	0x12	

For detailed instruction information, view full SSD1322 datasheet here (pages 32-47):

[http://www.newhavendisplay.com/app\\_notes/SSD1322.pdf](http://www.newhavendisplay.com/app_notes/SSD1322.pdf)

# Timing Characteristics – OLED

## 6800-MPU Parallel Interface

( $V_{DDIO} - V_{SS} = 2.1V - V_{CI}$ ,  $V_{CI} - V_{SS} = 2.4V - 3.5V$ ,  $T_A = 25^\circ C$ )

Symbol	Parameter	Min	Typ	Max	Unit
$t_{CYCLE}$	Clock Cycle Time (read)	300	-	-	ns
	Clock Cycle Time (write)	100	-	-	ns
$t_{AS}$	Address Setup Time	15	-	-	ns
$t_{AH}$	Address Hold Time	0	-	-	ns
$t_{DSW}$	Write Data Setup Time	40	-	-	ns
$t_{DHW}$	Write Data Hold Time	10	-	-	ns
$t_{DHR}$	Read Data Hold Time	20	-	-	ns
$t_{OH}$	Output Disable Time	-	-	70	ns
$t_{ACC}$	Access Time	-	-	140	ns
$PW_{CSL}$	Chip Select Low Pulse Width (read)	150	-	-	ns
	Chip Select Low Pulse Width (write)	60	-	-	ns
$PW_{CSH}$	Chip Select High Pulse Width (read)	60	-	-	ns
	Chip Select High Pulse Width (write)	60	-	-	ns
$t_R$	Rise Time	-	-	15	ns
$t_F$	Fall Time	-	-	15	ns

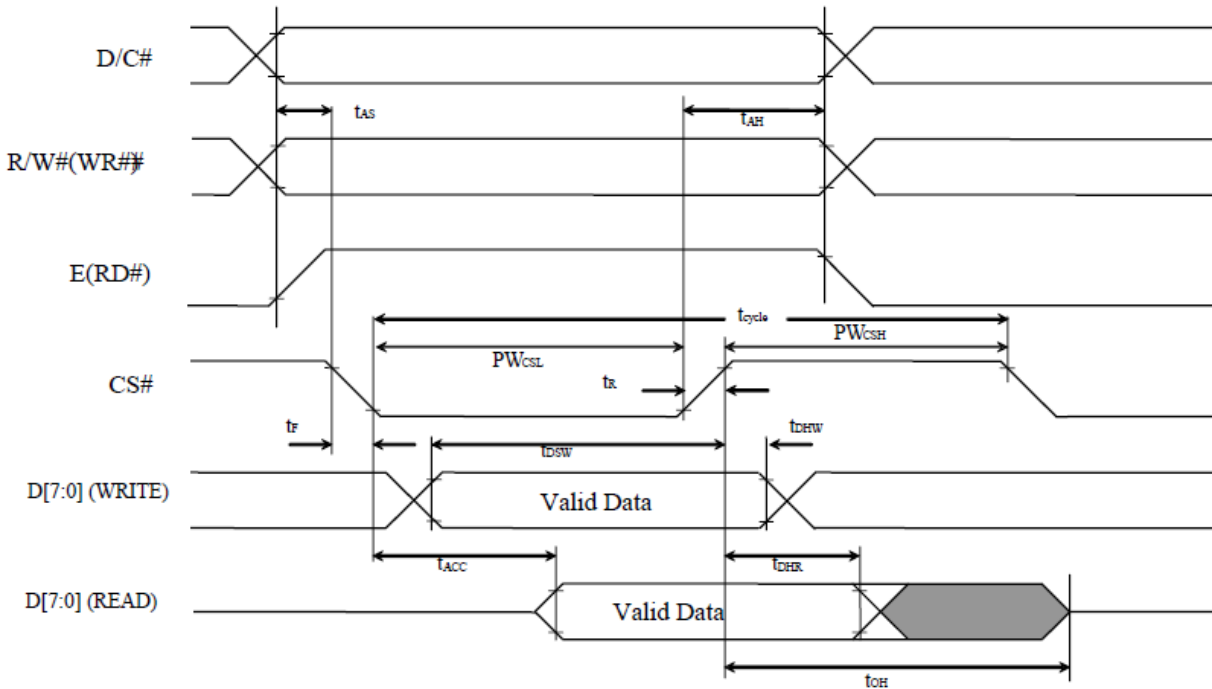

## 8080-MPU Parallel Interface

( $V_{DDIO} - V_{SS} = 2.1V - V_{CI}$ ,  $V_{CI} - V_{SS} = 2.4V - 3.5V$ ,  $T_A = 25^\circ C$ )

Symbol	Parameter	Min	Typ	Max	Unit
$t_{CYCLE}$	Clock Cycle Time (read)	300	-	-	ns
	Clock Cycle Time (write)	100	-	-	ns
$t_{AS}$	Address Setup Time	10	-	-	ns
$t_{AH}$	Address Hold Time	0	-	-	ns
$t_{DSW}$	Write Data Setup Time	40	-	-	ns
$t_{DHW}$	Write Data Hold Time	10	-	-	ns
$t_{DHR}$	Read Data Hold Time	20	-	-	ns
$t_{OH}$	Output Disable Time	-	-	70	ns
$t_{ACC}$	Access Time	-	-	140	ns
$t_{PWL R}$	Read Low Time	150	-	-	ns
$t_{PWL W}$	Write Low Time	60	-	-	ns
$t_{PWH R}$	Read High Time	60	-	-	ns
$t_{PWH W}$	Write High Time	60	-	-	ns
$t_R$	Rise Time	-	-	15	ns
$t_F$	Fall Time	-	-	15	ns
$t_{CS}$	Chip select setup time	0	-	-	ns
$t_{CSH}$	Chip select hold time to read signal	0	-	-	ns
$t_{CSF}$	Chip select hold time	20	-	-	ns

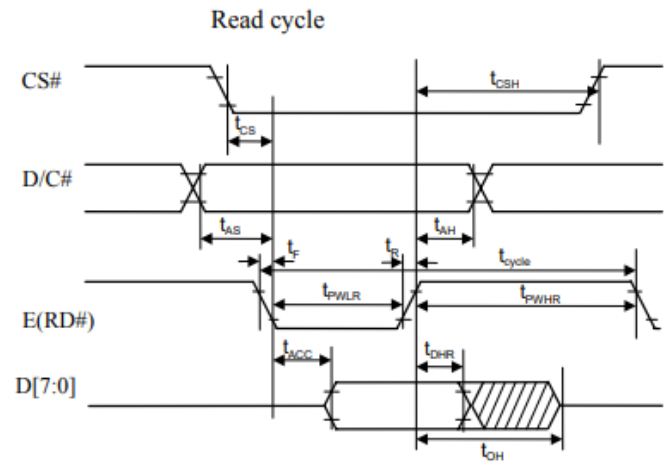
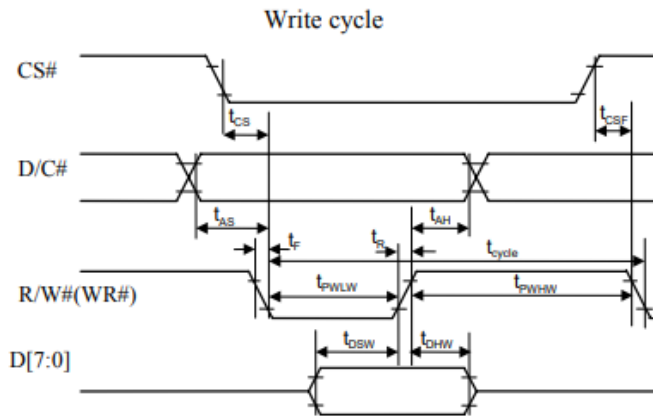

### Serial Interface (4-wire)

( $V_{DDIO} - V_{SS} = 2.1V - V_{Cl}$ ,  $V_{Cl} - V_{SS} = 2.4V - 3.5V$ ,  $T_A = 25^\circ C$ )

Symbol	Parameter	Min	Typ	Max	Unit
$t_{cycle}$	Clock Cycle Time	300	-	-	ns
$t_{AS}$	Address Setup Time	15	-	-	ns
$t_{AH}$	Address Hold Time	25	-	-	ns
$t_{CSS}$	Chip Select Setup Time	20	-	-	ns
$t_{CSH}$	Chip Select Hold Time	10	-	-	ns
$t_{DSW}$	Write Data Setup Time	15	-	-	ns </td
$t_{DHW}$	Write Data Hold Time	20	-	-	ns
$t_{CLKL}$	Clock Low Time	25	-	-	ns
$t_{CLKH}$	Clock High Time	40	-	-	ns
$t_R$	Rise Time	-	-	15	ns
$t_F$	Fall Time	-	-	15	ns

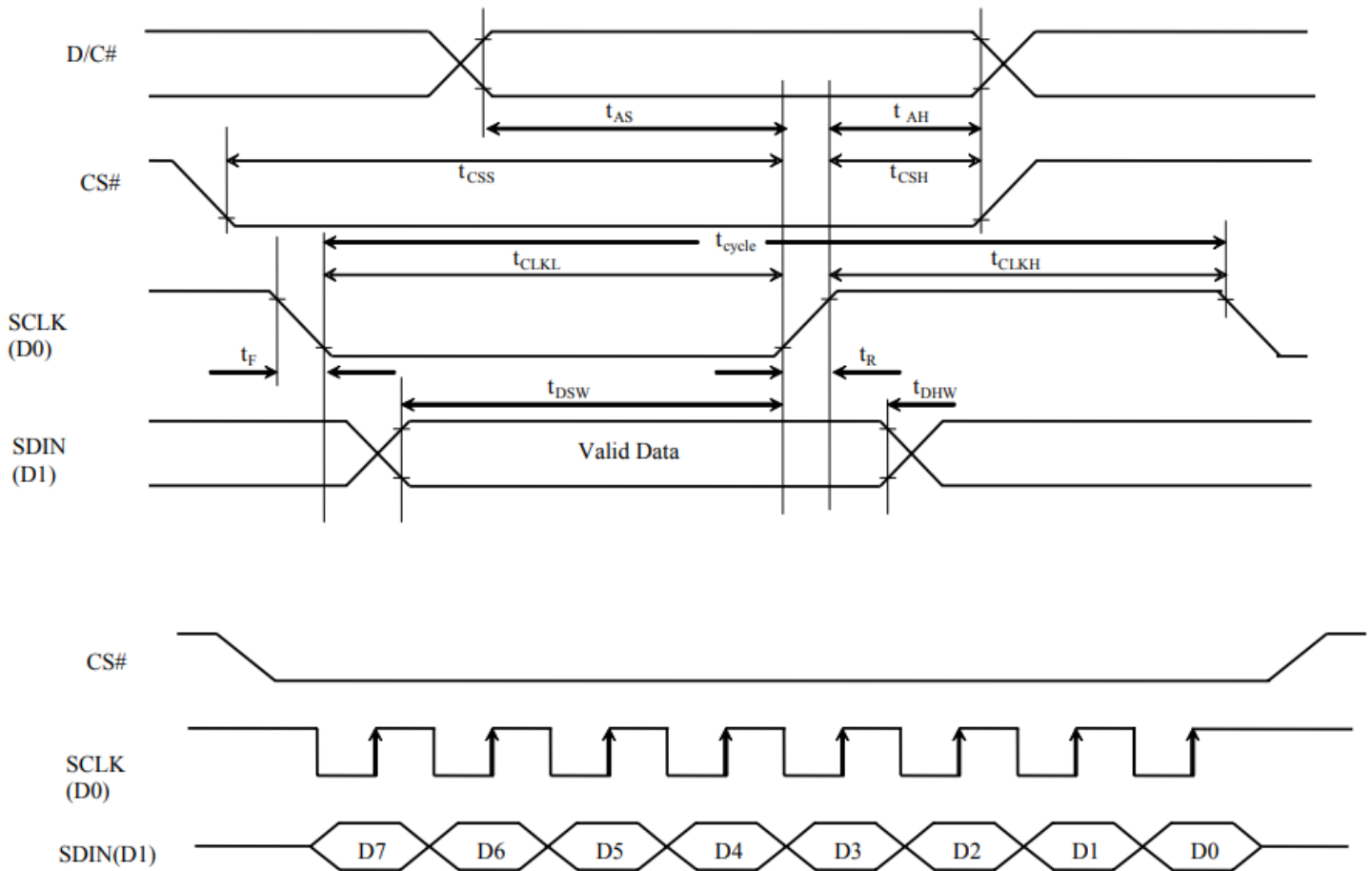

### Serial Interface (3-wire)

( $V_{DDIO} - V_{SS} = 2.1V - V_{Cl}$ ,  $V_{Cl} - V_{SS} = 2.4V - 3.5V$ ,  $T_A = 25^\circ C$ )

Symbol	Parameter	Min	Typ	Max	Unit
$t_{cyc}$	Clock Cycle Time	300	-	-	ns
$t_{CSS}$	Chip Select Setup Time	20	-	-	ns
$t_{CSH}$	Chip Select Hold Time	25	-	-	ns
$t_{DSW}$	Write Data Setup Time	15	-	-	ns
$t_{DHW}$	Write Data Hold Time	20	-	-	ns
$t_{CLKL}$	Clock Low Time	25	-	-	ns
$t_{CLKH}$	Clock High Time	25	-	-	ns
$t_R$	Rise Time	-	-	15	ns
$t_F$	Fall Time	-	-	15	ns

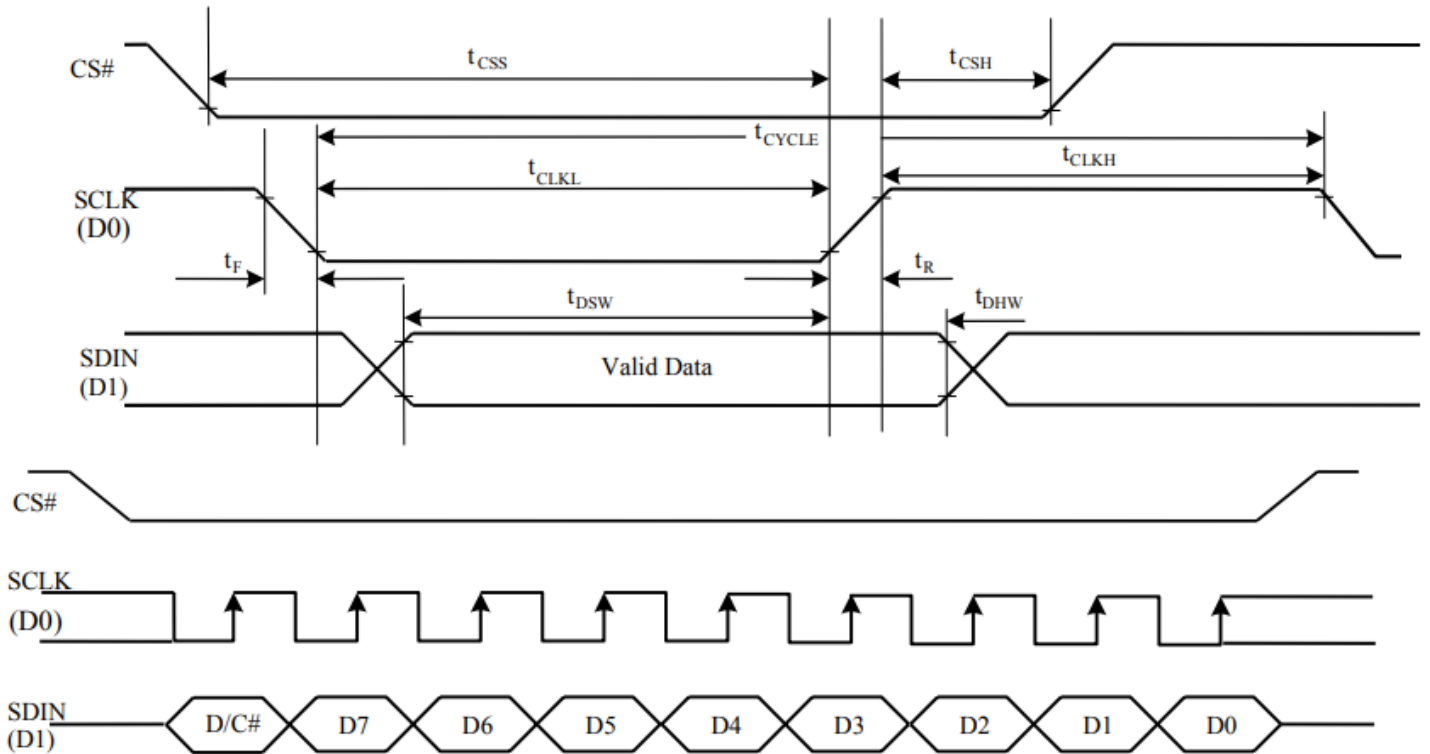

## Example Software Routines

### Code to initialize OLED:

```
void NHD12864WDY3_Init(void){
    digitalWrite(RESPIN, LOW);           //pull /RES (pin #16) low
    delayUS(200);                       //keep /RES low for minimum 200µs
    digitalWrite(RESPIN, HIGH);         //pull /RES high
    delayUS(200);                       //wait minimum 200µs before sending commands
    writeCommand(0xAE);                 //display OFF
    writeCommand(0xB3);                 //set CLK div. & OSC freq.
    writeData(0x91);
    writeCommand(0xCA);                 //set MUX ratio
    writeData(0x3F);
    writeCommand(0xA2);                 //set offset
    writeData(0x00);
    writeCommand(0xAB);                 //function selection
    writeData(0x01);
    writeCommand(0xA0);                 //set re-map
    writeData(0x16);
    writeData(0x11);
    writeCommand(0xC7);                 //master contrast current
    writeData(0x0F);
    writeCommand(0xC1);                 //set contrast current
    writeData(0x9F);
    writeCommand(0xB1);                 //set phase length
    writeData(0xF2);
    writeCommand(0xBB);                 //set pre-charge voltage
    writeData(0x1F);
    writeCommand(0xB4);                 //set VSL
    writeData(0xA0);
    writeData(0xFD);
    writeCommand(0xBE);                 //set VCOMH
    writeData(0x04);
    writeCommand(0xA6);                 //set display mode
    writeCommand(0xAF);                 //display ON
}
```



## Quality Information

Test Item	Content of Test	Test Condition	Note
High Temperature storage	Endurance test applying the high storage temperature for a long time.	+85°C, 240hrs	2
Low Temperature storage	Endurance test applying the low storage temperature for a long time.	-40°C, 240hrs	1,2
High Temperature Operation	Endurance test applying the electric stress (voltage & current) and the high thermal stress for a long time.	+85°C, 240hrs	2
Low Temperature Operation	Endurance test applying the electric stress (voltage & current) and the low thermal stress for a long time.	-40°C, 240hrs	1,2
High Temperature / Humidity Storage	Endurance test applying the electric stress (voltage & current) and the high thermal with high humidity stress for a long time.	+60°C, 90% RH, 240hrs	1,2
Thermal Shock resistance	Endurance test applying the electric stress (voltage & current) during a cycle of low and high thermal stress.	-40°C, 30min -> +25°C, 5min -> +85°C, 30min = 1 cycle 100 cycles	
Vibration test	Endurance test applying vibration to simulate transportation and use.	10-22Hz, 15mm amplitude. 22-500Hz, 1.5G 30min in each of 3 directions X, Y, Z	3
Atmospheric Pressure Test	Test the endurance of the display by applying atmospheric pressure to simulate transportation by air.	115mbar, 40hrs	3
Static electricity test	Endurance test applying electric static discharge.	Air: ±8KV; 300Ω, 150pF	
		Contact: ±4KV; 300Ω, 150pF	

**Note 1:** No condensation to be observed.

**Note 2:** Conducted after 2 hours of storage at 25°C, 0%RH.

**Note 3:** Test performed on product itself, not inside a container.