

AMR Sensor Evaluation Board

Product Engineering
Department
Sensor Products Division

April.2020
Rev.1



AMR sensor Evaluation Board (MRMS501A-001 mounted on board) *muRata*

INNOVATOR IN ELECTRONICS

An LED equipped board is available to confirm AMR sensor operations.

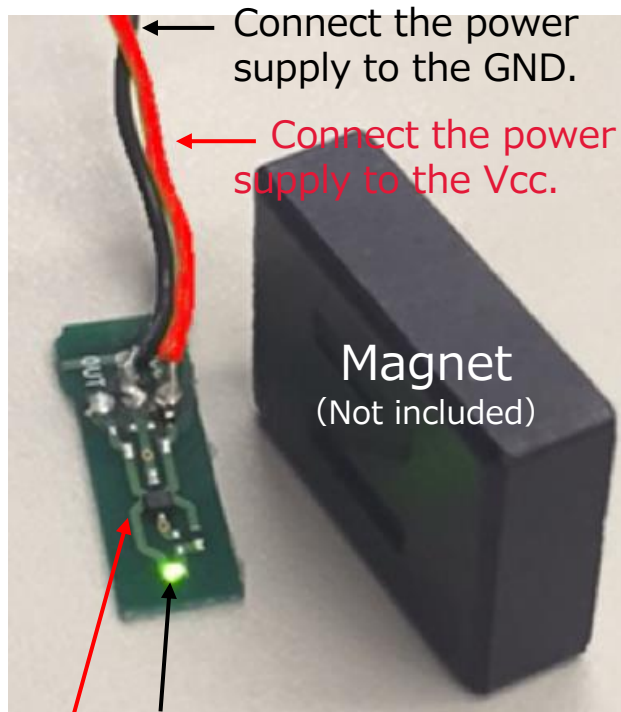

The LED lights up when the magnetic force is detected.

AMR sensor mounted on board

This board is used to confirm AMR sensor operations.

- Connect a power supply (3 - 5V) to the VCC and GND.
- The LED lights up when magnetic energy correctly enters the installed AMR sensor.

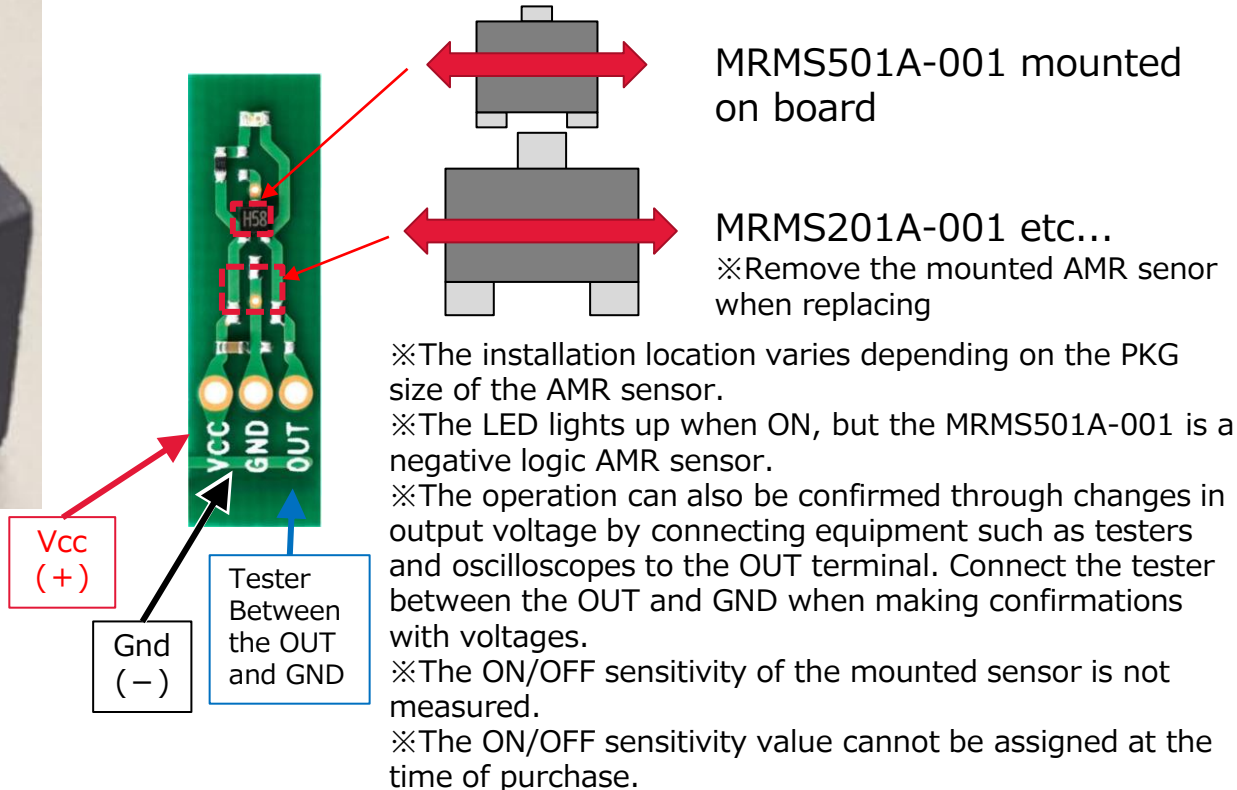

Please also refer to the evaluation board introduction page. It can be found in the parts handling website. (External Website)

URL: <https://www.murata.com/en-global/products/sensor/amr/design-development/evaluationboard>