



The Future of Analog IC Technology®

EV2635-R-01A

Full-Power-Management IC For Single-Cell Battery System

DESCRIPTION

The EV2635-R-01A is the evaluation board designed to demonstrate the capabilities of MPS' MP2635, a highly-integrated, flexible switch-mode battery charge management and system power path management device for a single-cell Li-ion and Li-Polymer battery used in a wide range of portable applications.

EV2635 uses two operating modes—charge mode and boost mode—to allow management of system and battery power based on the state of the input.

When input power is present, the board charges a single-cell battery with a programmable charge current of up to 2A.

In the absence of an input source, the board switches to boost mode through the MODE pin to power the SYS pins from the battery with a current of up to 1.5A.

The evaluation board provides full-operating-status indicators to distinguish charge mode from boost mode.

To guarantee safe operation, the EV2635 has input-over-voltage protection, battery over-voltage protection, thermal shutdown, battery-temperature monitoring, and a programmable timer to prevent prolonged charging of a dead battery.

ELECTRICAL SPECIFICATION

Parameter	Symbol	Value	Units
Charge Mode			
Input Voltage Range	V _{IN}	4.24 – 6	V
Charge-Full Voltage	V _{BATT_Full}	4.2 / 3.6	V
Charge Current	I _{CHG}	2	A
Input Current Limit	I _{IN_LIM}	2.7	A
Boost Mode			
Battery Voltage	V _{BATT}	2.5 – 4.35	V
SYS Voltage Regulation	V _{SYS}	5	V
SYS Output Current Limit	I _{SYS}	1.5	A

FEATURES

- 4.5V-to-6V Operating Input Voltage Range
- Power Management Function Integrated Input-Current-Limit and Input –Voltage - Regulation
- Up to 2A Programmable Charge Current
- Selectable 3.6V / 4.2V Charge Voltage with 0.5% Accuracy
- Battery Temperature Monitoring
- Full Operation Indicators
- Programmable Timer-Back-Up Protection
- Battery-Reverse-Leakage Blocking
- Reverse-Boost-Operation for Powering System
- Up to 91% 5V Boost Mode Efficiency @ 1A
- Up to 1.5A Programmable Output Current Limit in Boost Mode

APPLICATIONS

- Sub-battery Applications
- Power-bank Applications for Smart-Phone, Tablet and Other Portable Devices

All MPS parts are lead-free and adhere to the RoHS directive. For MPS green status, please visit MPS website under Products, Quality Assurance page.

"MPS" and "The Future of Analog IC Technology", are Registered Trademarks of Monolithic Power Systems, Inc.

EV2635-R-01A EVALUATION BOARD



(L x W x H) 6.1cm x 5.1cm x 1.3cm

Board Number	MPS IC Number
EV2635-R-01A	MP2635

EVALUATION BOARD SCHEMATIC

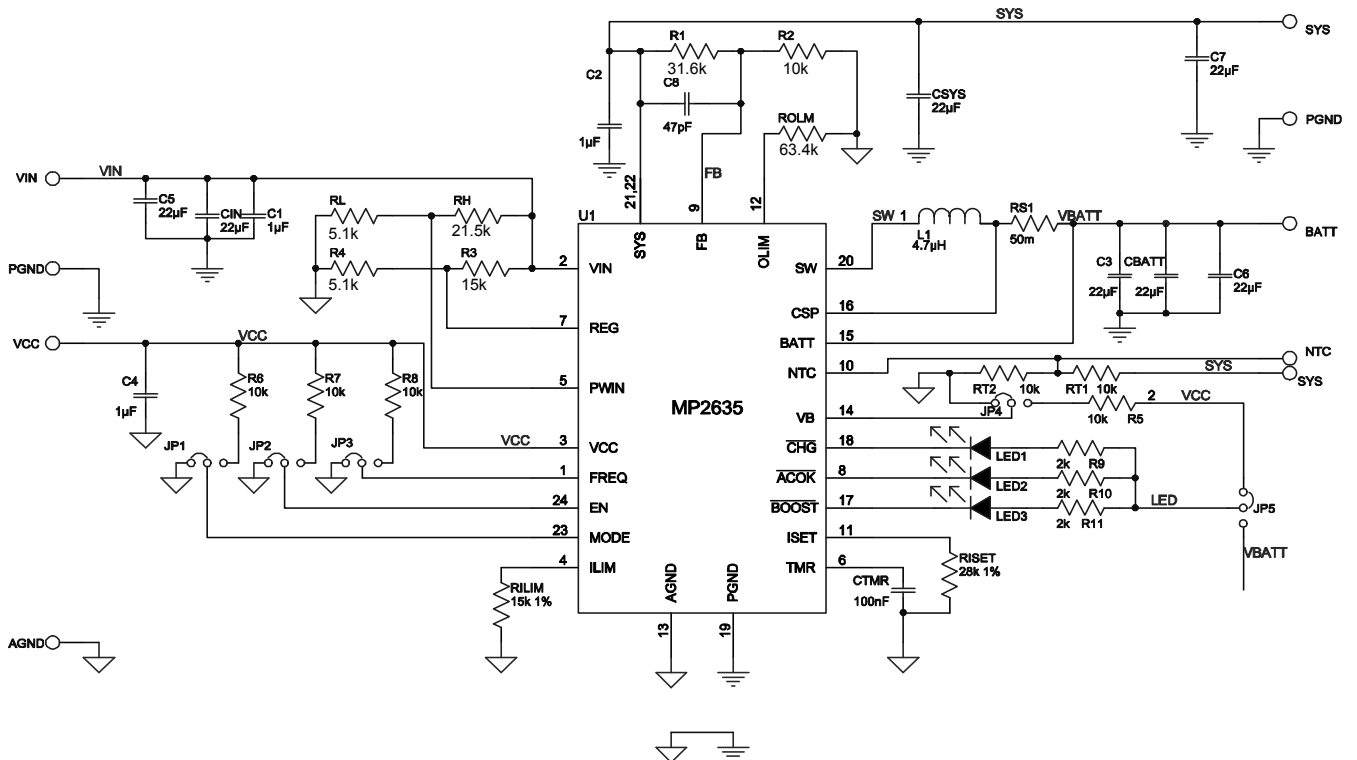

EV2635-R-01A BILL OF MATERIALS

Qty.	Ref	Value	Description	Package	Manufacture	Manufacture_PN
1	C1,	1 μ F	Ceramic Capacitor; 25V; X5R	CAP/0603	TDK	C1608X5R1E105K
1	C2	1 μ F	Ceramic Capacitor; 16V; X7R;	CAP/0603	muRata,	GRM188R71C105KA12D
4	C3, C7, CSYS, CBATT	22 μ F	Ceramic Capacitor; 10V; X7R;	CAP/1206	muRata	GRM31CR71A226KE15L
2	C4, CTMR	100nF	Ceramic Capacitor; 50V; X7R;	CAP/0603	muRata	GRM188R71H104KA93D
2	C5, C6	NC				
1	C8	47pF	Ceramic Capacitor; 50V; C0G;	CAP/0603	TDK	C1608C0G1H470J
1	CIN	22 μ F	Ceramic Capacitor; 25V; X5R;	CAP/1206	muRata	GRM31CR61E226KE15
1	L1	4.7 μ H	Inductor; 4.7uH;	SMD	Würth	744311470
					Cooper	DR73-4R7-R
2	LED1, LED3	BL-HUF35A-TRB	LED, Red	LED/SMD/0805	BRIGHT LED	BL-HUF35A-TRB
1	LED2	HL-PSC-2012H203BC	LED, Blue	LED/SMD/0805	BRIGHT LED	HL-PSC-2012H203BC
1	R1	31.6k 1%	Film Resistor; 1%;	RES/0603	Yageo	RC0603FR-0731K6L
4	R2, R5, RT1, RT2	10k 1%	Film Resistor; 1%;	RES/0603	Yageo	RC0603FR-0710KL
1	R3	15k	Film Resistor; 1%	RES/0603	Yageo	RC0603FR-0715KL
2	R4, RL	5.1k	Film Resistor; 1%	RES/0603	Yageo	RC0603FR-075K1L
3	R6, R7, R8	10k	Film Resistor; 5%;	RES/0603	Yageo	RC0603JR-0710K
3	R9, R10, R11	2k	Film Resistor; 5%; 1/10W	RES/0603	LIZ	CR0603JA0202G
1	RH	21.5k	Film Resistor; 1%	RES/0603	Yageo	RC0603FR-0721K5L
1	RILIM	15k 1%	Film Resistor; 1%;	RES/0603	Yageo	RC0603FR-0715KL
1	RISET	28k 1%	Film Resistor; 1%;	RES/0603	Yageo	RC0603FR-0728KL

EV2635-R-01A BILL OF MATERIALS (continued)

Qty.	Ref	Value	Description	Package	Manufacture	Manufacture_PN
1	ROLM	63.4k 1%	Film Resistor; 1%	RES/0603	Yageo	RC0603FR-0763K4L
1	RS1	50m	Sense Resistor; 1%; 1/2W;	RES/1206	Yageo	RL1206FR-070R050L
5	JP1, JP2, JP3, JP4, JP5		JUMPER/3P/DIP/2 .54mm			
1	U1			QFN24/4X4MM/EP	MPS	MP2635GR

PRINTED CIRCUIT BOARD LAYOUT

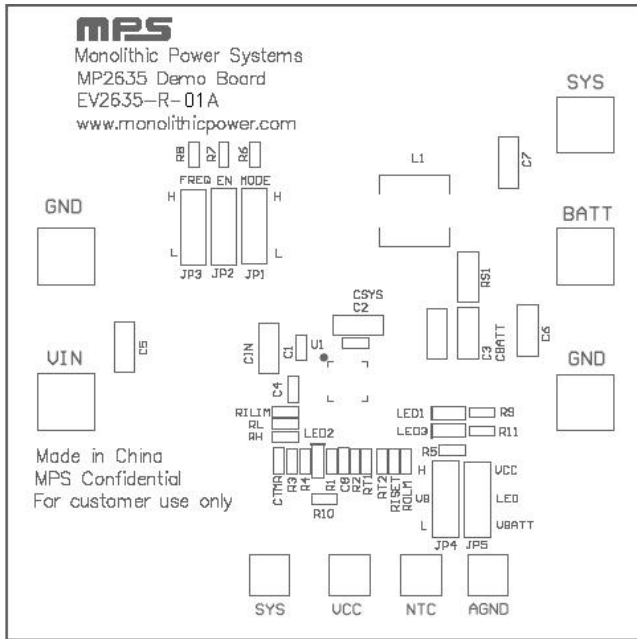

Figure 1: Top Silkscreen Layer

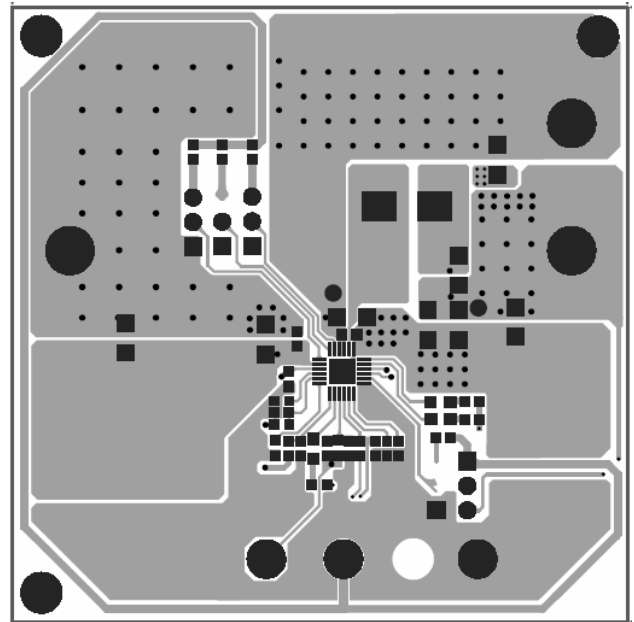

Figure 2: Top Layer

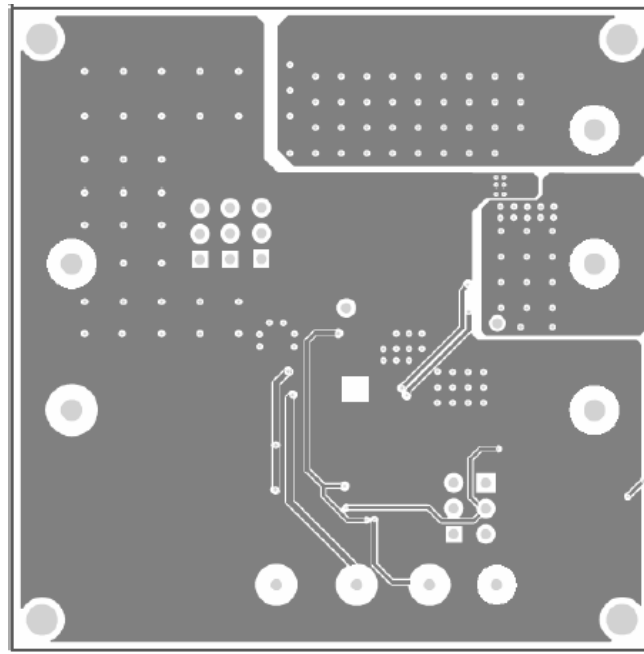

Figure 3: Bottom Layer

QUICK START GUIDE

This board is designed for the MP2635, a stand-alone switch-mode battery charge management and system power path management device with integrated reverse directional boost from BATT to SYS. The board' layout accommodates most commonly-used capacitors. The default function of this board is preset at charge mode, and the charge full voltage is preset to 4.2V for a 1-cell Li-Ion battery.

Charge Mode Setting

1. Input-Over-Voltage-Limit

The MP2635 has a PWIN pin to monitor the input voltage. Once the voltage input voltage at PWIN pin exceeds 1.15V, the input to system path is cut off to protect the device from being damaged. The maximum input is 6V, and the external resistor divider must meet the following equation:

$$\frac{V_{PWIN}}{V_{IN}} = \frac{1.15}{6} = \frac{R_L}{R_H + R_L} \quad (1)$$

Assume that $R_L=5.1k\Omega$, then R_H is $21.5k\Omega$.

2. REG Voltage

When the input power source is not sufficient to support both the charge current and system load current, the charge current is reduced to allow priority of system power and maintain the input voltage avoid dropping further. The REG pin is the input-voltage regulation feedback. The input voltage can be regulated by a resistor divider from VIN pin to REG pin to AGND

$$V_{REG} = 1.2V \times \frac{R_3 + R_4}{R_4} (V) \quad (2)$$

If $V_{REG}=4.75V$, given $R_4=5.1k\Omega$, then $R_3=15k\Omega$.

3. Input Current Limit

An input current limit can be set slightly below the input source's maximum current rating. When the input current hits this limit, the charge current will decrease to keep the input current constant at the limit value to initially power the system. R_{ILIM} —the resistor connected to the ILIM pin—programs this limit. To set the input current limit at 2.7A, use an R_{ILIM} of $15k\Omega$.

$$I_{ILIM} (A) = \frac{40.5(kV)}{R_{ILIM} (k\Omega)} \quad (3)$$

4. Charge-Full Voltage

To set the charge-full voltage, either leave the VB pin floating, or connect it to high logic for 4.2V and to connect to GND for 3.6V.

5. Charge Current

The charge current can be programmed via both R_{S1} and R_{ISET} . With given $R_{S1}=50m\Omega$, determine the charge current using the following formula:

$$I_{CHG} (A) = \frac{70(k\Omega)}{R_{ISET} (k\Omega)} \times \frac{40(mV)}{R_{S1} (m\Omega)} \quad (4)$$

For example, for a charge current of 2A, use a $28k\Omega$ R_{ISET} .

6. Charge Timer

The MP2635 has a charge timer as an extra precaution against charging damaged batteries. The total charge time can be set as:

$$\tau_{\text{TOTAL_TMR}} = 6\text{Hours} \times \frac{C_{\text{TMR}}(\mu\text{F})}{0.1\mu\text{F}} \times \frac{1\text{A}}{I_{\text{CHG}}(\text{A})} \quad (5)$$

So if the charge current is 2A, a C_{TMR} of 0.1 μF provides a $t_{\text{TOTAL_TMR}}$ of 3 hours.

Boost Mode

1. System Output Voltage

The MODE pin can enable or disable the EV2635 when in boost mode. The resistor divider—R1 and R2—can adjust the output voltage as per the following equation:

$$V_{\text{SYS_REG}}(\text{V}) = 1.2\text{V} \times \frac{R1 + R2}{R2} \quad (6)$$

Select R1 and R2 as 31.6k Ω and 10k Ω , respectively, for a system voltage of 5V.

2. System-Output-Current Limit

Set the system-output-current limit in boost mode for the EV2635 to operate like a standard adapter. Set the output current limit as per the following equation:

$$I_{\text{OLIM}}(\text{A}) = \frac{70(\text{k}\Omega) \times 40(\text{mV}) \times 1.7}{R_{\text{OLIM}}(\text{k}\Omega) \times RS1(\text{m}\Omega)} \quad (7)$$

Others

1. Operating Frequency

The operating frequency can be programmed to optimize the design for both charge and boost modes. Set the frequency to 1.2MHz by connecting the FREQ pin to “H” or leaving the FREQ pin floating, while set to 600kHz by connecting the FREQ pin to “L”.

For the other detailed description on the operation of the MP2635, please refer to the datasheet.

EQUIPMENT REQUIREMENT

Evaluation requires the following equipments:

1. DC power source. The output voltage should exceed 6V, and output current greater than 2A.
2. Battery simulator or a single-cell battery pack. The battery simulator's output rating should exceed 4.5V/2.5A. When using a real battery pack, please observe all precautions on the battery manufacturer's data sheet first and ensure the charger's setting doesn't exceed the battery's absolute maximum specifications.
3. An oscilloscope. A single voltage probe and a single current probe.
4. Multi-meter.

Charge Function

- 1 Connect the jumper "EN" to "H" and the "MODE" to "L" to shunts, respectively!
- 2 Attach the positive and negative ends of the battery to the "BATT" and "GND" terminals, respectively. If it's a battery simulator, please preset the voltage to 3.8V (typical value) first.
- 3 Preset the DC power source to 5V. Then attach the DC output port and ground to the "VIN" and "GND" terminals, respectively.
- 4 Turn on the DC power source. The charger will start. Use the oscilloscope to verify that the 2A charge current is being delivered to the battery.
- 5 Remove the shunt between the "EN" and "H" to disable charging.
- 6 Re-insert the shunt between the "EN" and "H" to enable charging.

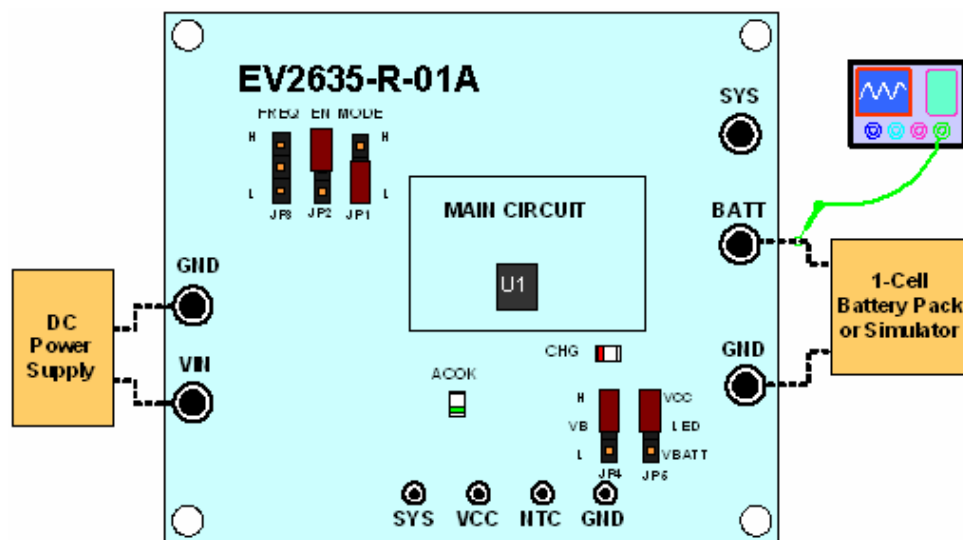

Figure 4: Setup for Charge Mode

Boost Function

- 1 Connect the jumper “MODE” to “H” and the “EN” to “L” with shunts respectively!
- 2 Attach the load to the “SYS” and “GND” terminals respectively.
- 3 Attach the positive and negative ends of the battery to the “BATT” and “GND” terminals respectively. If it’s a battery simulator, please preset the voltage to 3.8V (typical value) firstly. The boost will start to work. Verify the system output current is limited at 1.5A.
- 4 Remove the shunt between the “MODE” and “H” to disable boost.
- 5 Install the shunt between the “MODE” and “H” to enable boost.

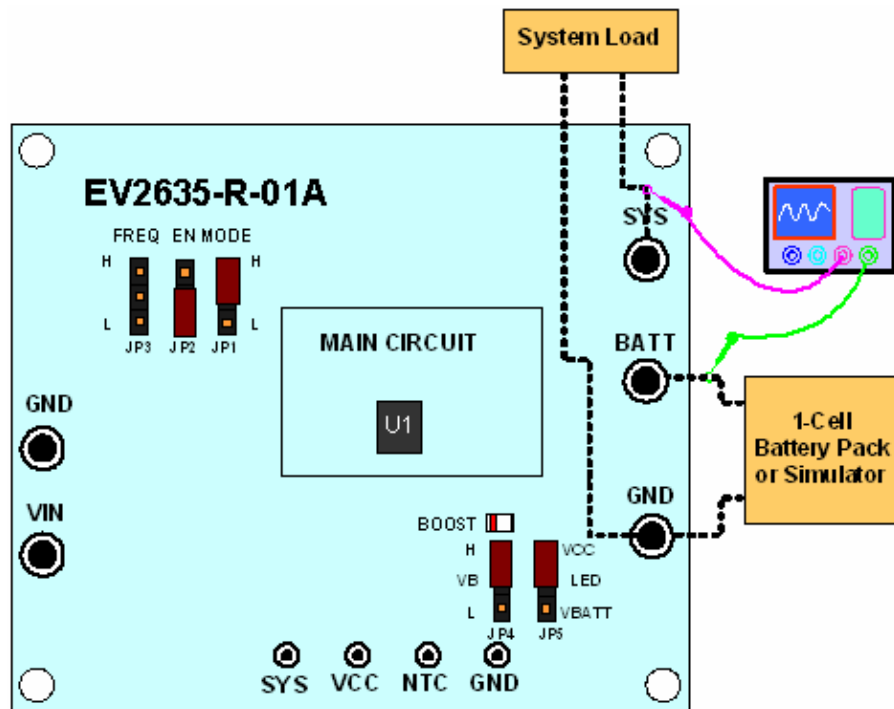

Figure 5: Setup for Boost Mode

NOTICE: The information in this document is subject to change without notice. Users should warrant and guarantee that third party Intellectual Property rights are not infringed upon when integrating MPS products into any application. MPS will not assume any legal responsibility for any said applications.