

DESCRIPTION

The EV2619-V-01A is an evaluation board for the MP2619, a switching, high-performance 2-3 cell Li-Ion battery charger with built in internal power MOSFET for power path application.

MP2619 achieves up to 2A charge current over a wide input supply range. The charge current can be programmed by sensing the current through an accurate sense resistor.

MP2619 regulates the battery voltage and charge current using two control loops to realize high accuracy CC charge and CV charge.

Fault condition protection includes time out control, battery full terminated control, thermal protection, battery temperature monitoring and protection. The board also indicates AC adapter power good and charge status indications to the system.

ELECTRICAL SPECIFICATION

Parameter	Symbol	Value	Units
Input Voltage	V_{IN}	10~24	V
Charge Current	I_{CHG}	2	A

FEATURES

- Charge 2-, 3- cell Li-Ion Battery Packs
- Wide Operating Input Range
- 2A Charging Current
- $\pm 0.75\%$ V_{BATT} Accuracy
- Up to 90% Efficiency
- Fixed 600kHz Frequency
- Preconditioning for fully depleted batteries
- Charging Operation Indicator
- Input Supply and battery fault indicator
- Thermal Shutdown
- Battery Temperature Monitor and Protection

APPLICATIONS

- Distributed Power Systems
- Smart Phones
- Net-book

All MPS parts are lead-free, halogen free, and adhere to the RoHS directive. For MPS green status, please visit MPS website under Quality Assurance. "MPS" and "The Future of Analog IC Technology" are Registered Trademarks of Monolithic Power Systems, Inc.

EV2619-V-01A EVALUATION BOARD



(L x W x H) 2.5" x 2.5" x 0.5"
(6.35cm x 6.35cm x 1.2cm)

Board Number	MPS IC Number
EV2619-V-01A	MP2619EV

2 Cells Battery Charge Curve

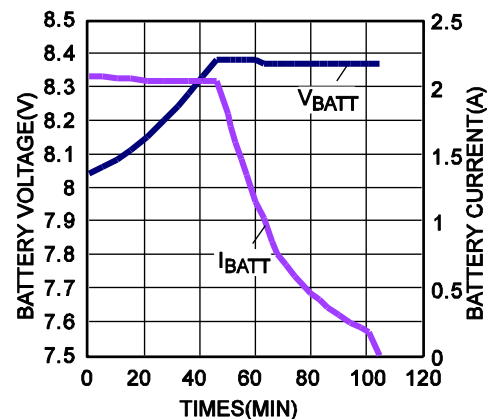

EVALUATION BOARD SCHEMATIC

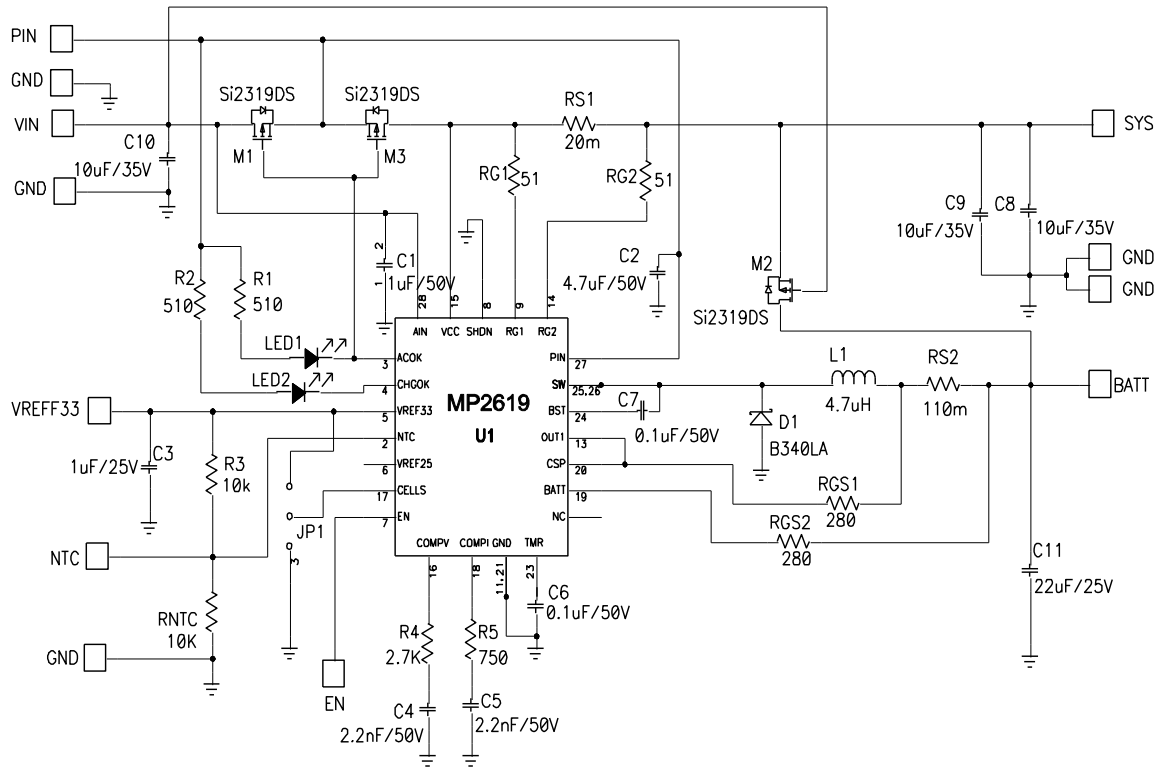

EV2619-V-01A BILL OF MATERIALS

Qty	Ref	Value	Description	Package	Manufacturer	Manufacturer P/N
1	C1	1 μ F	Ceramic Cap., 50V, X7R	0805	Murata	GRM21BR71H105KA12L
1	C2	4.7 μ F	Ceramic Cap., 50V, X7R	1210	Murata	GRM32ER71H475KA88L
1	C11	22 μ F	Ceramic Cap., 25V, X5R	1210	Murata	GRM32ER61E226KE15L
1	C3	1 μ F	Ceramic Cap., 25V, X5R	0603	TDK	C1608X5R1E105K
2	C4, C5	2.2nF	Ceramic Cap., 50V, X7R	0603	TDK	C1608X7R1H222K
2	C6, C7	0.1 μ F	Ceramic Cap., 50V, X7R	0603	Murata	GRM188R71H104KA93D
3	C8, C9, C10	10 μ F	Ceramic Cap, 35V, X7R	1210	Murata	GRM32ER7YA106KA12L
2	R1, R2	510 Ω	Film Res., 5%	0805	LIZ	0805J510R
1	R3	10k Ω	Film Res., 1%	0603	Yageo	RC0603FR-0710KL
1	R4	2.7k Ω	Film Res., 5%	0603	LIZ	CR0603JA0272K
1	R5	750 Ω	Film Res., 1%	0603	Yageo	RC0603FR-07750RL
2	RG1, RG2	51 Ω	Film Res., 1%	0603	Yageo	RC0603FR-0751RL
2	RGS1, RGS2	280 Ω	Film Res., 1%	0603	Yageo	RC0603FR-07280RL
1	RS1	20m	Film Res., 1%	1206	Vishay	WSL1206-18
1	RS2	110m	Film Res., 1%	2512	Vishay	WSL2512-18
1	RNTC	10k Ω	Film Res., 1%	0603	Vishay	NTCS0603E3103*MT
1	JP1		3-Pin Connector Header, 0.100"		Sullins	PTC03SAAN
1	LED1	Green	Led Green, Surface Mount	0805		
1	LED2	Red	Led Red, Surface Mount	0805		
1	D2		Diode Schottky, 80V, 3A	SMA	Diodes Inc	B340LA-13F
1	L1	4.7 μ H	Inductor, 3.8A	SMD	Toko	DS84LC-B1015AS-4R7N
			Inductor, 3.78A	SMD	Cooper	DR37-4R7-R
			Inductor, 6.5A	SMD	Würth	74431490
3	M1, M2, M3	40V/2.4A	PMOS	SOT23	Vishay	Si2319DS
1	U1		Switching Charger	QFN28	MPS	MP2619EV

PRINTED CIRCUIT BOARD LAYOUT

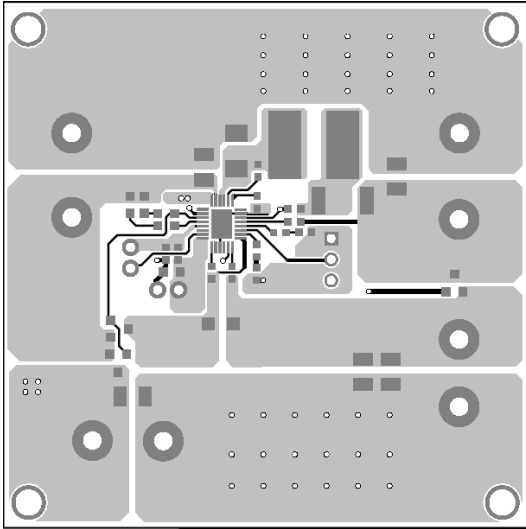

Figure 1—Top Layer

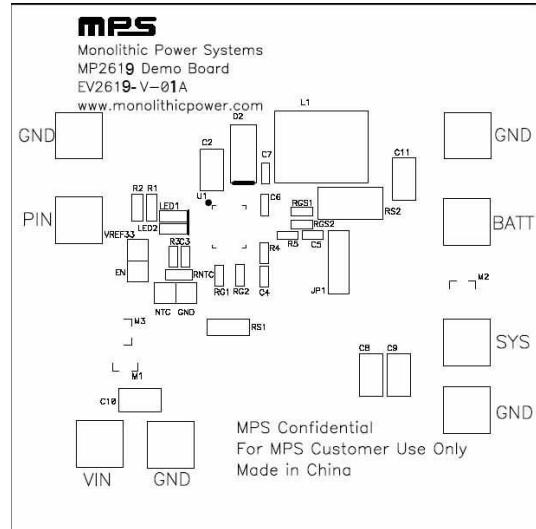

Figure 2—Top Silk Layer

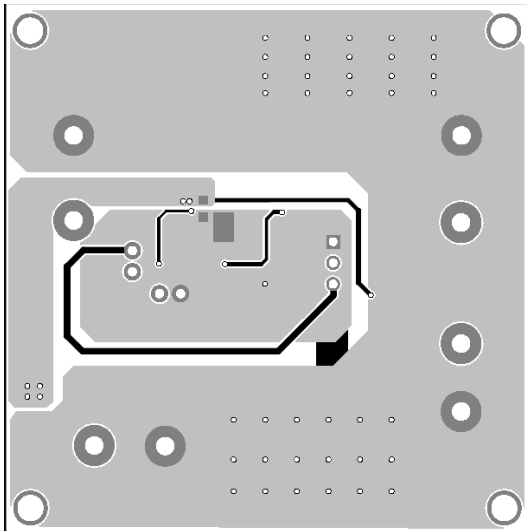

Figure 3—Bottom Layer

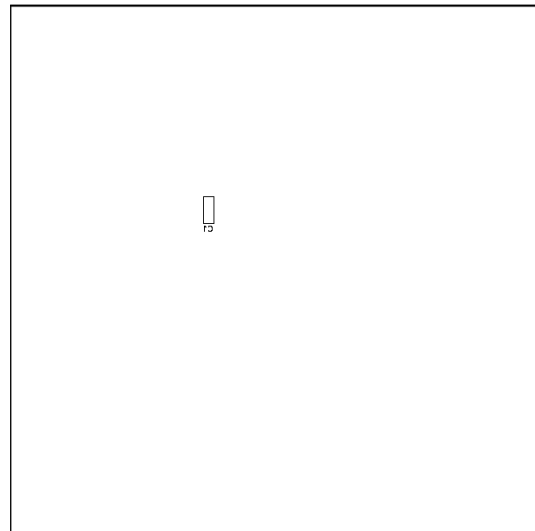

Figure 4—Bottom Silk Layer

QUICK START GUIDE

This board can be used for the application of MP2619 as a switching charger with power path management. The board layout accommodates most commonly used capacitors.

The default output voltage on this board is preset to 8.4V for 2 cell Li-Ion battery. Change Cell pin connecting to VREF33, the output is regulated to 12.6V for 3 cell Li-Ion batteries.

The two LEDs are charger status indicators. When the input is OK for charging the battery load, LED1 will turn on. Otherwise it is off. When the charging operation is normal, the LED2 is on. And after the battery full or no battery connected, LED 2 will turn off.

1. Charge current setting:

The charge current can be programmed by the sense resistor RS2, the formula is as:

$$I_{\text{CHG}}(\text{A}) = \frac{200\text{mV}}{\text{RS2}(\text{m}\Omega)}$$

For the switching charger with power path management application, as influenced by MP8110's sense error, the charge current sense resistance needs calibration. In the application, choose RS1 as small as possible for less the power loss (20mΩ on this board). RG1 and RG2 is 50Ω on this board. Then, RS2 need to be changed to 110mΩ for setting 2A charge current with RGS1 and RGS2 set at 280Ω. Following table is the value of calibrated RS2, RGS1 and RGS2 for setting different charge current.

$I_{\text{CHG}}(\text{A})$	RGS1(Ω)	RGS2(Ω)	RS2(mΩ)
2	280	280	110
1.5	402	402	160
1	665	665	260
0.8	909	909	360
0.5	2k	2k	800

- In the switching charger with power path management application, LED1 and LED2 need to be powered by V_{IN} .
- Attached the input voltage ($V_{\text{IN}}=19\text{V}$) and the input ground to the VIN and GND pins, respectively.
- Attach the positive and negative ends of the load to the SYS and GND pins, respectively.
- Attach the positive and negative ends of the battery to the BATT and GND pins, respectively.

NOTICE: The information in this document is subject to change without notice. Please contact MPS for current specifications. Users should warrant and guarantee that third party Intellectual Property rights are not infringed upon when integrating MPS products into any application. MPS will not assume any legal responsibility for any said applications.