



DSR0.3A THRU DSR0.3M

Reverse Voltage - 50 to 1000 Volts Forward Current - 0.3 Ampere

SURFACE MOUNT GENERAL PURPOSE SILICON RECTIFIER

Features

- ◆ Glass passivated device
- ◆ Ideal for surface mounted applications
- ◆ Low reverse leakage
- ◆ Metallurgically bonded construction
- ◆ High temperature soldering guaranteed:
- ◆ 250°C/10 seconds, 0.375" (9.5mm) lead length, 5 lbs. (2.3kg) tension

Mechanical Data

Case: JEDEC UOD-123FL molded plastic body
 Terminals: Solderable per MIL-STD-750, Method 2026A
 Polarity: Polarity symbol marking on body
 Mounting Position: Any
 Weight: 0.0067 ounce, 0.02 grams

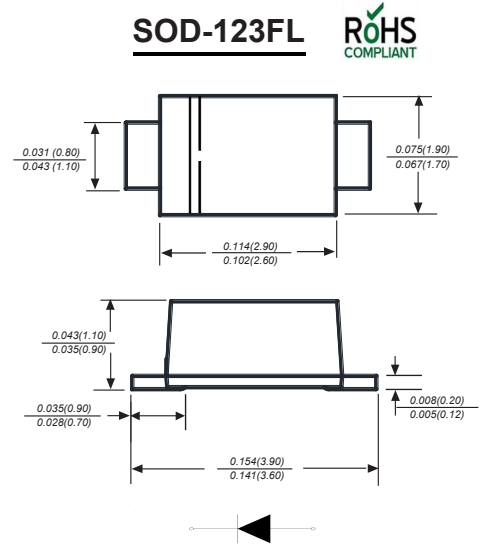

Dimensions in inches and (millimeters)

Maximum Ratings And Electrical Characteristics

Ratings at 25°C ambient temperature unless otherwise specified.

Single phase half-wave 60Hz, resistive or inductive load, for capacitive load current derate by 20%.

Parameter	SYMBOLS	DSR0.3A	DSR0.3B	DSR0.3D	DSR0.3G	DSR0.3J	DSR0.3K	DSR0.3M	UNITS
		S03A	S03B	S03D	S03G	S03J	S03K	S03M	
Maximum repetitive peak reverse voltage	V_{RRM}	50	100	200	400	600	800	1000	V
Maximum RMS voltage	V_{RMS}	35	70	140	280	420	560	700	V
Maximum DC blocking voltage	V_{DC}	50	100	200	400	600	800	1000	V
Maximum average forward rectified current at TL(see fig.1)	$I_{(AV)}$	0.3							A
Peak forward surge current 8.3ms single half sine-wave superimposed on rated load (JEDEC Method)	I_{FSM}	15.0							A
Maximum instantaneous forward voltage at 2.0A	V_F	1.1							V
Maximum DC reverse current $T_A=25^\circ C$ at rated DC blocking voltage $T_A=125^\circ C$	I_R	5.0 50							μA
Typical junction capacitance (NOTE 1)	C_J	4							pF
Typical thermal resistance (NOTE 2)	$R_{\theta JA}$	220							$^\circ C/W$
Operating junction temperature range	T_J	-55 to +150							$^\circ C$
Storage temperature range	T_{STG}	-55 to +150							$^\circ C$

- Note:** 1. Averaged over any 20ms period.
 2. Measured at 1MHz and applied reverse voltage of 4.0V D.C.
 3. Thermal resistance from junction to ambient at 0.375" (9.5mm) lead length, P.C.B. mounted



DSR0.3A THRU DSR0.3M

Reverse Voltage - 50 to 1000 Volts Forward Current - 0.3 Ampere

Typical Characteristics

Characteristic Curves ($T_A=25^\circ\text{C}$ unless otherwise noted)

Fig.1 Forward Current Derating Curve

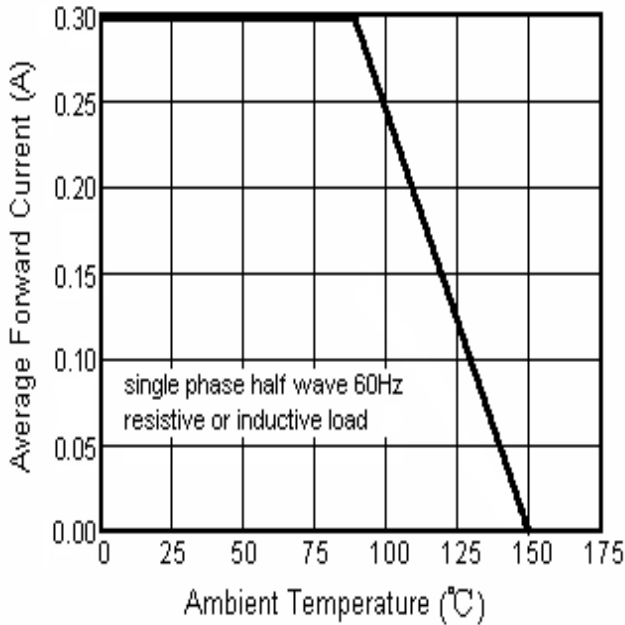

Fig.2 Maximum Non-Repetitive Peak Forward Surge Current

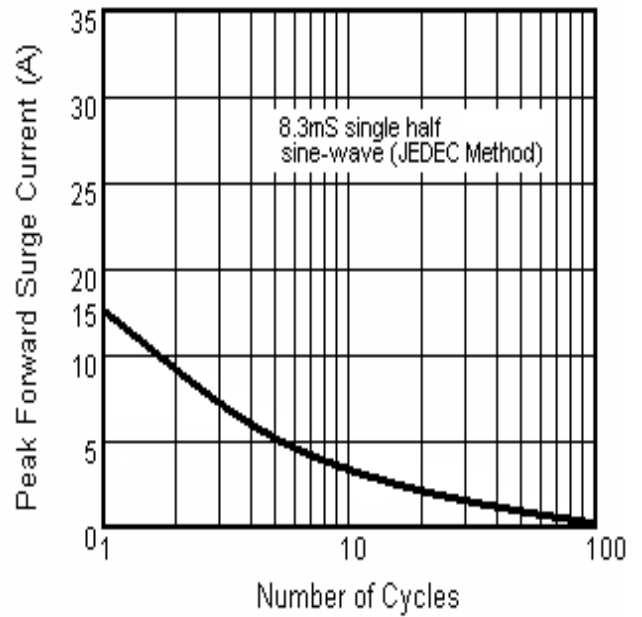

Fig.3 Typical Instantaneous Forward Characteristics

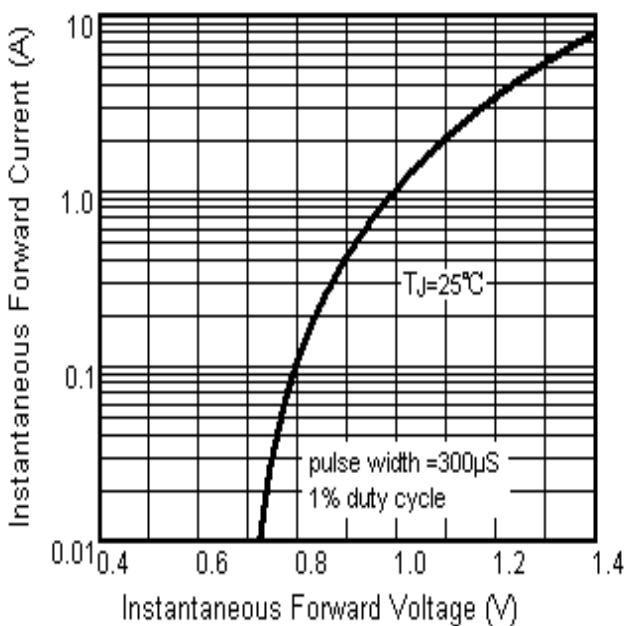
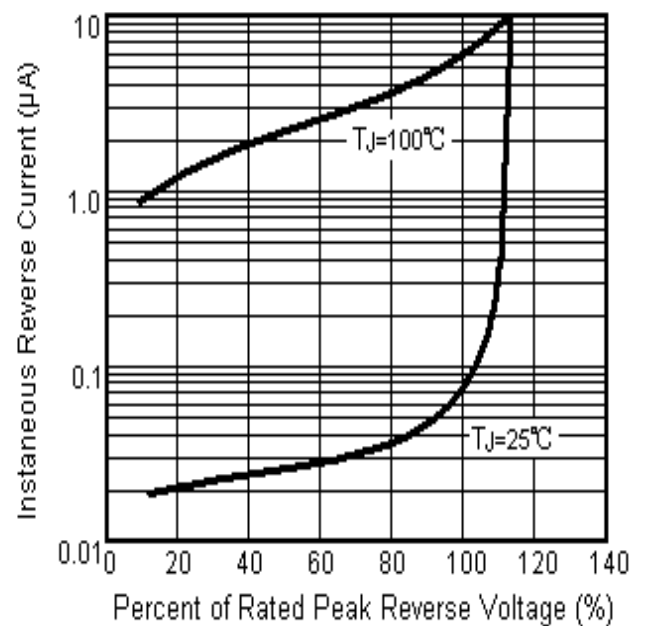

Fig.4 Typical Reverse Characteristics



The curve above is for reference only.



DSR0.3A THRU DSR0.3M

Reverse Voltage - 50 to 1000 Volts Forward Current - 0.3 Ampere

Packing information

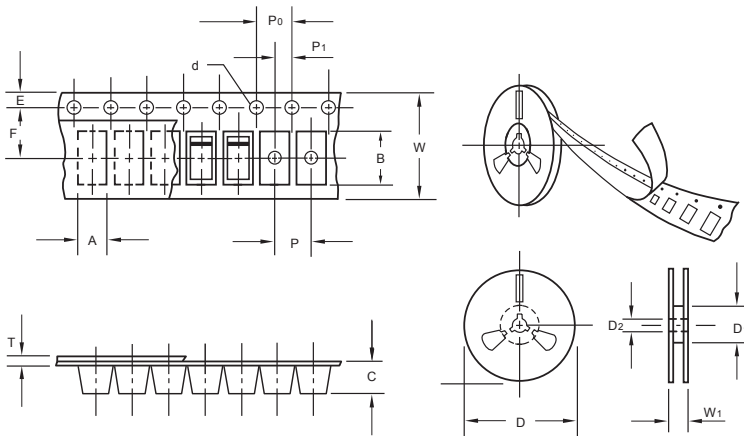

unit:mm

Item	Symbol	Tolerance	SOD-123FL
Carrier width	A	0.1	2.1
Carrier length	B	0.1	4.0
Carrier depth	C	0.1	1.60
Sprocket hole	d	0.05	1.55
7" Reel outside diameter	D	2.0	178.00
7" Reel inner diameter	D1	min	50.0
Feed hole diameter	D2	0.5	13.00
Sprocket hole position	E	0.1	1.75
Punch hole position	F	0.1	3.50
Punch hole pitch	P	0.1	4.00
Sprocket hole pitch	P0	0.1	4.00
Embossment center	P1	0.1	2.00
Overall tape thickness	T	0.1	0.25
Tape width	W	0.3	8.15
Reel width	W1	1.0	10.5

Note: Devices are packed in accordance with EIA standard RS-481-A and specifications listed above.

Reel packing

PACKAGE	REEL SIZE	REEL (pcs)	COMPONENT SPACING (m/m)	BOX (pcs)	INNER BOX (m/m)	REEL DIA, (m/m)	CARTON SIZE (m/m)	CARTON (pcs)	APPROX. GROSS WEIGHT (kg)
SOD-123FL	7"	3,000	4.0	45,000	210*208*203	178	430*430*235	180,000	9.0

Suggested Pad Layout



Symbol	Unit (mm)	Unit (inch)
A	1.2	0.047
B	1.2	0.047
C	3.2	0.126
D	2	0.079
E	4.4	0.173