

650V N-CHANNEL MOSFET

◆ Features:

- ◇ Fast switching speed  
开关速度快
- ◇ High input impedance and low level drive  
高输入阻抗和低电平驱动
- ◇ Avalanche energy tested  
雪崩能量测试
- ◇ Improved dv/dt capability, high ruggedness  
提高 dv/dt 能力, 高耐用性

◆ Applications

- ◇ High efficiency switch mode power supplies  
高效率开关电源
- ◇ Power factor correction  
功率因数校正
- ◇ Electronic lamp ballast  
电子整流器

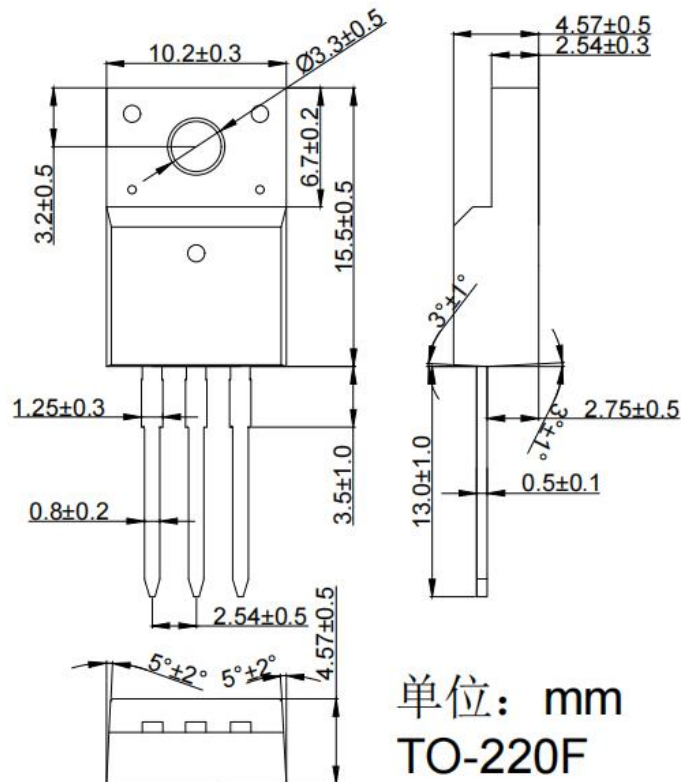
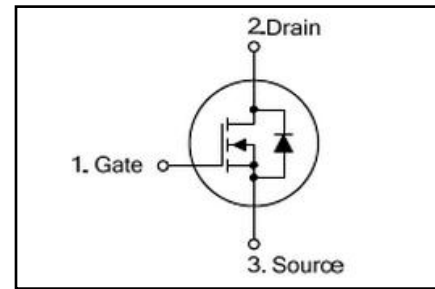
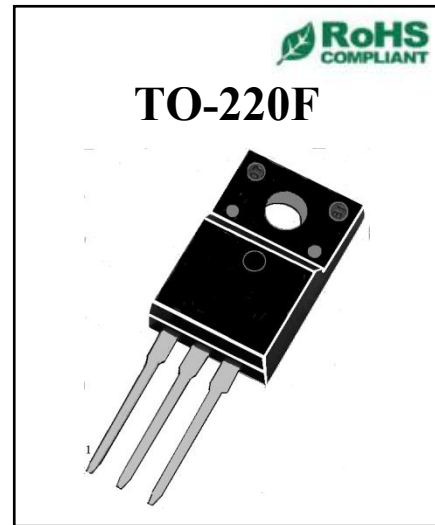

**◆ Absolute Maximum Ratings (Tc=25°C)**

Symbol	Parameters	Ratings	Unit
V <sub>DSS</sub>	Drain-Source Voltage 漏源电压	<b>650</b>	V
V <sub>GS</sub>	Gate-Source Voltage-Continuous 栅源电压	<b>±30</b>	V
I <sub>D</sub>	Drain Current-Continuous (Note 2) 漏极持续电流	<b>16</b>	A
I <sub>DM</sub>	Drain Current-Single Plused (Note 1) 漏极单次脉冲电流	<b>64</b>	A
P <sub>D</sub>	Power Dissipation (Note 2) 功率损耗	<b>62</b>	W
T <sub>j</sub>	Max.Operating junction temperature 最大结温	<b>150</b>	°C

**◆ Electrical characteristics (Tc=25°C unless otherwise noted)**

Symbol	Parameters	Min	Typ	Max	Units	Conditions
<b>Static Characteristics</b>						
B <sub>VDSS</sub>	Drain-Source Breakdown VoltageCurrent (Note 1) 漏极击穿电压	<b>650</b>	--	--	V	I <sub>D</sub> =250μA, V <sub>GS</sub> =0V, T <sub>J</sub> =25°C
V <sub>GS(th)</sub>	Gate Threshold Voltage 栅极开启电压	<b>2.0</b>	--	<b>4.0</b>	V	V <sub>DS</sub> =V <sub>GS</sub> , I <sub>D</sub> =250μA
R <sub>DS(on)</sub>	Drain-Source On-Resistance 漏源导通电阻	--	<b>0.52</b>	--	Ω	V <sub>GS</sub> =10V, I <sub>D</sub> =8A
I <sub>GSS</sub>	Gate-Body Leakage Current 栅极漏电流	--	--	<b>±90</b>	nA	V <sub>GS</sub> =±30V, V <sub>DS</sub> =0
I <sub>DSS</sub>	Zero Gate Voltage Drain Current 零栅极电压漏极电流	--	--	<b>200</b>	nA	V <sub>DS</sub> =650V, V <sub>GS</sub> =0
g <sub>fs</sub>	Forward Transconductance 正向跨导	--	<b>6.0</b>	--	S	V <sub>DS</sub> =30V, I <sub>D</sub> =8A

Switching Characteristics						
$T_{d(on)}$	Turn-On Delay Time 开启延迟时间	--	<b>16</b>	--	ns	$V_{DS}=325V, I_D=16A,$ $R_G=25\Omega$ (Note 2)
$T_r$	Rise Time 上升时间	--	<b>45</b>	--	ns	
$T_{d(off)}$	Turn-Off Delay Time 关闭延迟时间	--	<b>85</b>	--	ns	
$T_f$	Fall Time 下降时间	--	<b>18</b>	--	ns	
$Q_g$	Total Gate Charge 栅极总电荷	--	<b>55</b>	--	nC	$V_{DS}=520V$ , $V_{GS}=0-10V,$ $I_D=16A$ (Note 2)
$Q_{gs}$	Gate-Source Charge 栅源极电荷	--	<b>15</b>	--	nC	
$Q_{gd}$	Gate-Drain Charge 栅漏极电荷	--	<b>21</b>	--	nC	
Dynamic Characteristics						
$C_{iss}$	Input Capacitance 输入电容	--	<b>2800</b>	--	pF	$V_{DS}=25V, V_{GS}=0,$ $f=1MHz$
$C_{oss}$	Output Capacitance 输出电容	--	<b>380</b>	--	pF	
$C_{rss}$	Reverse Transfer Capacitance 反向传输电容	--	<b>20</b>	--	pF	
$I_S$	Continuous Drain-Source Diode Forward Current (Note 2) 二极管导通正向持续电流	--	--	<b>16</b>	A	
$V_{SD}$	Diode Forward On-Voltage 二极管正向导通电压	--	--	<b>0.9</b>	V	$I_S=1A, V_{GS}=0$
$R_{th(j-c)}$	Thermal Resistance, Junction to Case 结到外壳的热阻	--	--	<b>2.02</b>	$^{\circ}C/W$	

Note 1: Repetitive Rating : Pulse width limited by maximum junction temperature

Note 2: Pulse test: PW  $\leq$  300us , duty cycle  $\leq$  2%.