

Rockchip RK628D Datasheet

**Revision 1.0
Nov. 2020**

Revision History

Date	Revision	Description
2020-11-06	1.0	Initial released

Table of Content

Table of Content3

Figure Index4

Table Index.....5

Warranty Disclaimer.....6

Chapter 1 Introduction 7

 1.1 Features7

 1.2 Block Diagram9

Chapter 2 Package Information.....10

 2.1 Order Information 10

 2.2 Top Marking 10

 2.3 WBBGA144 Dimension 10

 2.4 WBBGA144 Pin Number Order..... 12

 2.5 WBBGA144 Ball Map..... 14

 2.6 Pin Description..... 14

 2.7 RK628D Power/Ground IO Description..... 14

 2.8 RK628D Function IO Description..... 15

 2.9 IO Pin Name Description 17

 2.10 RK628D IO Type..... 17

Chapter 3 Electrical Specification20

 3.1 Absolute Maximum Ratings..... 20

 3.2 Recommended Operating Condition 20

 3.3 DC Characteristics 20

 3.4 Recommended Operating Frequency 21

Figure Index

Fig. 1-1 RK628D Block Diagram.....	9
Fig. 2-1 Package Definition	10
Fig. 2-2 RK628D WBBGA144 Package Top View and bottom View	10
Fig. 2-3 RK628D WBBGA144 Package side View	11
Fig. 2-4 RK628D WBBGA144 Package side View	11
Fig. 2-5 RK628D WBBGA144 Package Dimension	11
Fig. 2-6 RK628D BGA144 Ball Map	14

Table Index

Table 1-1 RK628D Video input interface	7
Table 1-2 RK628D Video output interface	8
Table 2-1 RK628D WBBGA144 Pin Number Order Information	12
Table 2-2 RK628D Power/Ground IO Information for BGA628	14
Table 2-3 RK628D Function IO Description	15
Table 2-4 RK628D IO Function Description List.....	17
Table 2-5 RK628D IO Type List	18
Table 3-1 RK628D Absolute Maximum Ratings	20
Table 3-2 RK628D Recommended Operating Condition	20
Table 3-3 RK628D DC Characteristics.....	20
Table 3-4 RK628D Recommended Operating Frequency.....	21

Warranty Disclaimer

Rockchip Electronics Co., Ltd makes no warranty, representation or guarantee (expressed, implied, statutory, or otherwise) by or with respect to anything in this document, and shall not be liable for any implied warranties of non-infringement, merchantability or fitness for a particular purpose or for any indirect, special or consequential damages.

Information furnished is believed to be accurate and reliable. However, Rockchip Electronics Co., Ltd assumes no responsibility for the consequences of use of such information or for any infringement of patents or other rights of third parties that may result from its use.

Rockchip Electronics Co., Ltd.'s products are not designed, intended, or authorized for using as components in systems intended for surgical implant into the body, or other applications intended to support or sustain life, or for any other application in which the failure of the Rockchip Electronics Co., Ltd.'s product could create a situation where personal injury or death may occur, should buyer purchase or use Rockchip Electronics Co., Ltd.'s products for any such unintended or unauthorized application, buyers shall indemnify and hold Rockchip Electronics Co., Ltd and its officers, employees, subsidiaries, affiliates, and distributors harmless against all claims, costs, damages, expenses, and reasonable attorney fees arising out of, either directly or indirectly, any claim of personal injury or death that may be associated with such unintended or unauthorized use, even if such claim alleges that Rockchip Electronics Co., Ltd was negligent regarding the design or manufacture of the part.

Copyright and Patent Right

Information in this document is provided solely to enable system and software implementers to use Rockchip Electronics Co., Ltd 's products. There are no expressed or implied copyright licenses granted hereunder to design or fabricate any integrated circuits or integrated circuits based on the information in this document.

Rockchip Electronics Co., Ltd does not convey any license under its patent rights nor the rights of others.

All copyright and patent rights referenced in this document belong to their respective owners and shall be subject to corresponding copyright and patent licensing requirements.

Trademarks

Rockchip and Rockchip™ logo and the name of Rockchip Electronics Co., Ltd.'s products are trademarks of Rockchip Electronics Co., Ltd. and are exclusively owned by Rockchip Electronics Co., Ltd. References to other companies and their products use trademarks owned by the respective companies and are for reference purpose only.

Confidentiality

The information contained herein (including any attachments) is confidential. The recipient hereby acknowledges the confidentiality of this document, and except for the specific purpose, this document shall not be disclosed to any third party.

Reverse engineering or disassembly is prohibited.

ROCKCHIP ELECTRONICS CO., LTD. RESERVES THE RIGHT TO MAKE CHANGES IN ITS PRODUCTS OR PRODUCT SPECIFICATIONS WITH THE INTENT TO IMPROVE FUNCTION OR DESIGN AT ANY TIME AND WITHOUT NOTICE AND IS NOT REQUIRED TO UNDATE THIS DOCUMENTATION TO REFLECT SUCH CHANGES.

Copyright © 2020 Rockchip Electronics Co., Ltd.

All rights reserved. No part of this publication may be reproduced, stored in a retrieval system, or transmitted in any form or by any means, electric or mechanical, by photocopying, recording, or otherwise, without the prior written consent of Rockchip Electronics Co., Ltd.

Chapter 1 Introduction

RK628D is a high-integration interface chip, which can support HDMI /parallel RGB /BT.1120 as input and dual MIPI/dual LVDS/GVI(general video interface)/parallel RGB/ BT.1120 as output with featured scaler inside. The key application scenario is extension of display output port for original application processor such as RK3288 /RK3399, or HDMI in interface providing.

1.1 Features

The features listed below which may or may not be present in actual product, may be subject to the third party licensing requirements. Please contact Rockchip for actual product feature configurations and licensing requirements.

1.1.1 Video input interface

- HDMI RX interface
 - Compliant with HDMI 1.4/HDMI 2.0
 - Supports 8/10bit per component video format
 - Supports rgb888/yuv420
 - Supports Max resolution 4k@60fps (yuv420)
 - Supports DDC Bus I2C master interface at 3.3/5V
 - Supports EDID and CEC function
- Parallel RX interface
 - Supports Max resolution 1080p@60fps
 - Supports 16bits BT.1120 in
 - Supports 24bits parallel RGB in

Table 1-1 RK628D Video input interface

Interface	Resolution	Data rate	Bit rate per lane
HDMI	4k@60fps	NA	3Gbps
BT.1120	1080p@60fps	148.5M	NA
RGB	1080p@60fps	148.5M	NA

1.1.2 Video output interface

- HDMI TX interface
 - Supports all DTV resolutions including 720p /1080p
 - Supports data rate from 25MHz, 1.65bps up to 3.4Gbps over a Single channel HDMI Internal SRAM
 - TMDS Tx Drivers with programmable output swing, resister values and pre-emphasis
 - DDC Bus I2C master interface at 3.3/5V
 - The EDID and CEC function are also supported by HDMI Transmitter Controller
- MIPI TX interface
 - DSI
 - ◆ Compliant with MIPI DPHY V1.2
 - ◆ Support the DPI interface color coding mappings into 24-bit Interface
 - ◆ Up to 4 DPHY Data Lanes per channel
 - ◆ Supports data rate up to 1.2Gbps
 - ◆ Supports dual channel ,DSI0 and DSI1
 - CSI
 - ◆ Compliant with MIPI DPHY V1.2
 - ◆ Support format: YUV422
 - ◆ Up to 4 DPHY Data Lanes
 - ◆ Supports data rate up to 1.2Gbps
 - ◆ Supports single channel ,combine with DSI0
- GVI TX interface
 - Supports RGB666/RGB888/RGB101010/YCbCR422-8bit/YCBCR422-10bit format
 - Supports Max resolution 4k@60fps
 - Supports up to 3.75Gbps data rate(effective data rate 3Gbps)
 - Supports 1/2/4/8 lanes

- Supports output lanes flexible mapping
- Supports 1/2 section mode
- LVDS TX interface
 - Compliant with the Standard TIA/EIA-644-A LVDS standard
 - Supports data rate up to 1Gbps
 - Support 8bit format-1, format-2, format-3 display mode, Support 6bit display mode.
 - Supports dual channel LVDS
- Parallel TX interface
 - Supports Max resolution 1080p@60fps
 - Supports 16bits BT.1120 out
 - Supports 24bits parallel RGB out

Table 1-2 RK628D Video output interface

Interface	Resolution	Data rate	Bit rate per lane
GVI	4k@60fps	NA	3.75Gbps
Dual MIPI	2k@60fps	NA	1.2Gbps
MIPI	1080p@60fps	NA	1.2Gbps
Dual LVDS	1080p@60fps	NA	1 Gbps
LVDS	720p@60fps	NA	1 Gbps
BT.1120	1080p@60fps	148.5M	NA
RGB	1080p@60fps	148.5M	NA
HDMI	1080p@60fps	148.5M	NA

1.1.3 TX/RX adapter

- Interaction of HDP signal between HDMI TX and HDMI RX
- Support HDMI TX CEC function
- Support RX HDCP1.3 inside-key memory. It is writable
- Support HDMI RX/TX
- Support on-chip EDID memory. It is readable and writable

1.1.4 Post process

- CSC
 - RGB2YUV
 - YUV2RGB
 - YUV2VYU
- Display interface
 - Parallel display Interface: 30-bit(RGB/YUV)
 - Asynchronous output pixel clock (PLL required)
 - Flexible display timing setting
 - Configurable border black area
- Scaling down
 - Max input resolution: 4096x2160
 - Arbitrary non-integer scaling ratio
 - Support two mode: bilinear and average
 - Max 1/4 scaling ratio for bilinear scaling down
 - Max 1/6 scaling ratio for average scaling down
- Scaling up
 - Max output resolution: 4096x2160
 - Arbitrary non-integer scaling ratio
 - Support four scaling up mode for different effect
 - Max 6 scaling ratio
- Split
 - Left-right mode
 - Odd-even mode(LVDS only)

1.1.5 Others

- Audio

- Support HDMI RX I2S interface, up to 48kHz sample rate, 8 channel
- Support I/O I2S interface, 8 channel
- Support HDMI TX I2S interface, 8 channel
- EFUSE
 - One-time programmable nonvolatile EFUSE storage cells organized as 64x8 bits
 - 1.1V typical core voltage
 - AVDD is NOT allowed to exceed 2.75V
 - Burning requirements:
 - ◆ 2.5V typical burning voltage (AVDD), AVDD must be high during PGM mode. AVDD must be low or floating during READ mode and inactive mode
 - ◆ 2us burning pulse width
 - ◆ Ambient temperature range of 10~40°C
 - ◆ Burning at wafer, package, or field level
- Package Type
 - BGA144(body: 8mmx8mm; ball size: 0.3mm; ball pitch: 0.65mm)

1.2 Block Diagram

The following diagram shows the basic block diagram for RK628D.

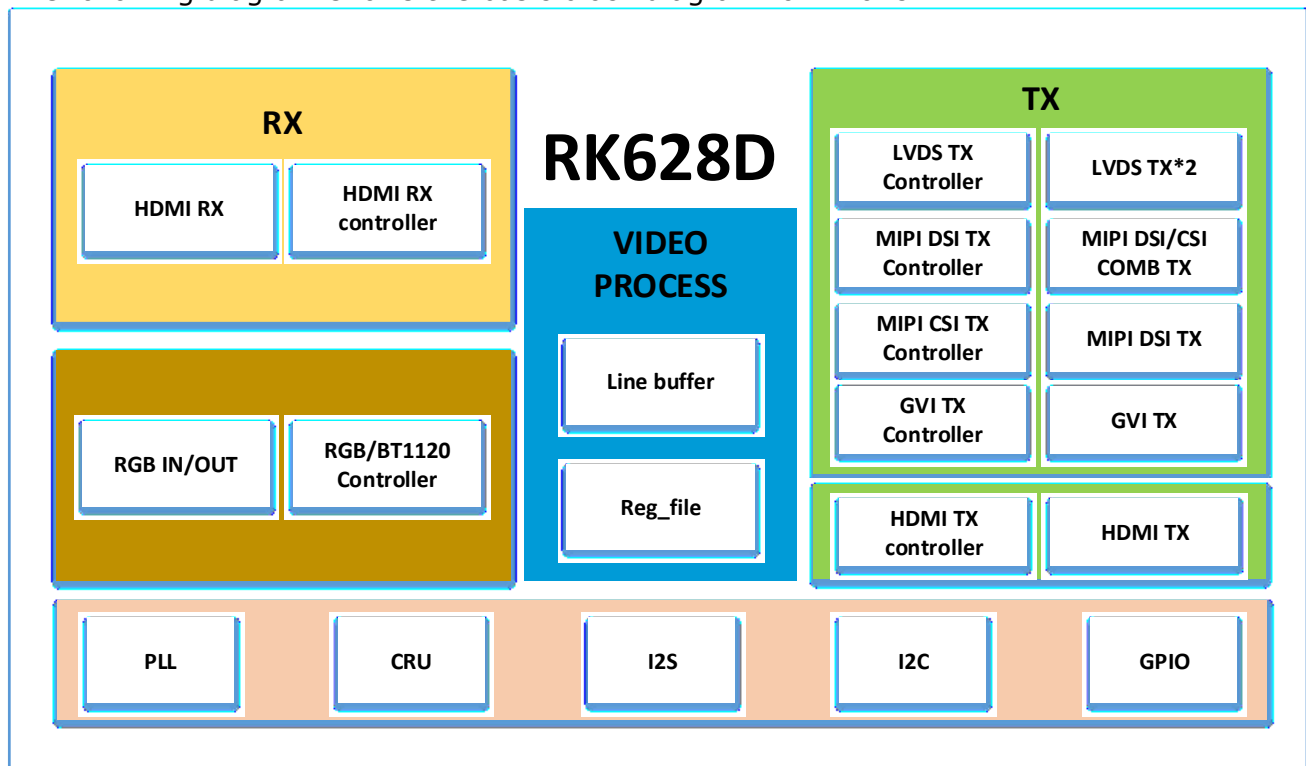

Fig. 1-1 RK628D Block Diagram

Chapter 2 Package Information

2.1 Order Information

Orderable Device	RoHS status	Package	Package Qty	Device Feature
RK628D	RoHS	WBBGA144	3480pcs by tray	High speed interface bridge chip

2.2 Top Marking

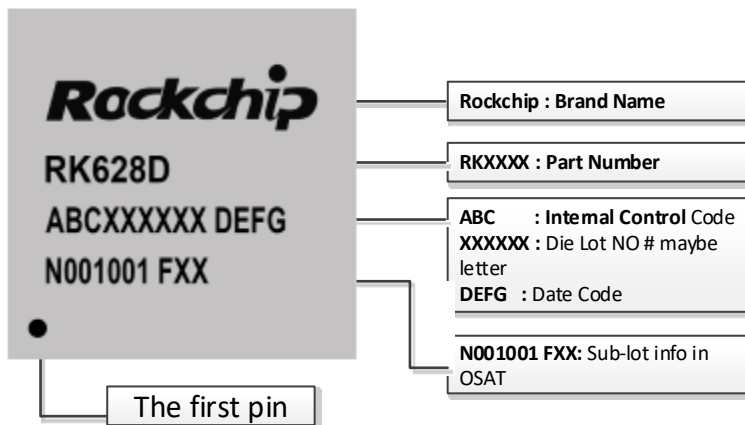

Fig. 2-1 Package Definition

2.3 WBBGA144 Dimension

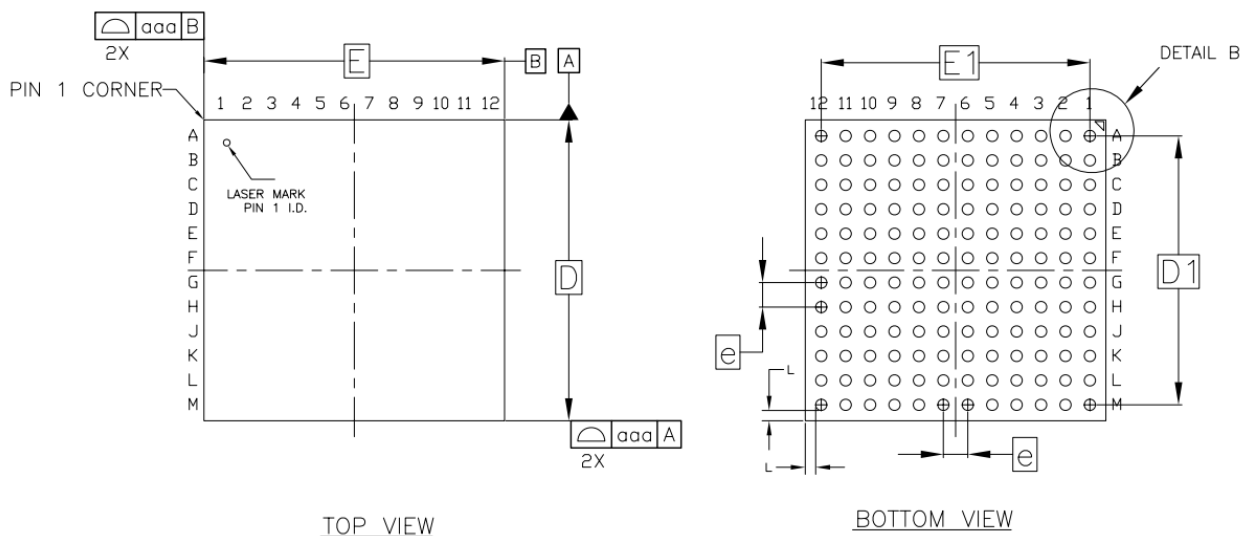

Fig. 2-2 RK628D WBBGA144 Package Top View and bottom View

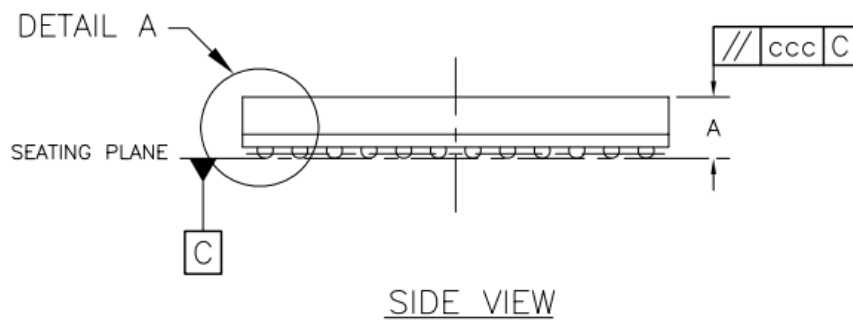

Fig. 2-3 RK628D WBBGA144 Package side View

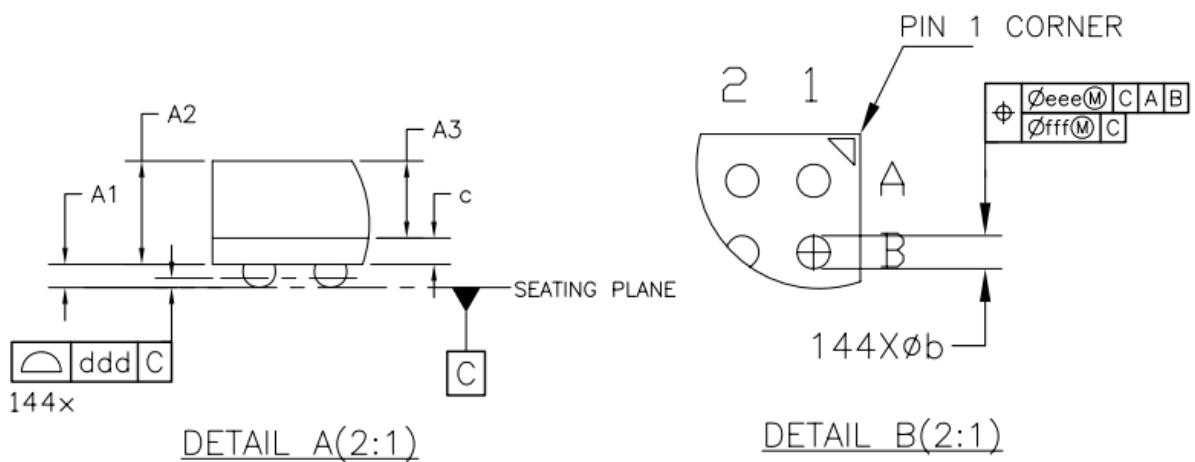

Fig. 2-4 RK628D WBBGA144 Package side View

SYMBOL	MILLIMETER		
	MIN	NOM	MAX
A	--	1.15	1.23
A1	0.16	0.21	0.26
A2	0.89	0.94	0.99
A3	0.70 BASIC		
c	0.20	0.24	0.28
D	7.90	8.00	8.10
D1	7.15 BASIC		
E	7.90	8.00	8.10
E1	7.15 BASIC		
e	0.65 BASIC		
b	0.25	0.30	0.35
L	0.275 REF		
aaa	0.15		
ccc	0.15		
ddd	0.10		
eee	0.15		
fff	0.08		

Fig. 2-5 RK628D WBBGA144 Package Dimension

Note:

1. CONTROLLING DIMENSION: MILLIMETER.

2. PRIMARY DATUM C AND SEATING PLANE ARE DEFINED BY THE SPHERICAL CROWNS OF THE SOLDER BALLS.
3. DIMENSION *b* IS MEASURED AT THE MAXIMUM SOLDER BALL DIAMETER, PARALLEL TO PRIMARY DATUM C.
4. SPECIAL CHARACTERISTICS C CLASS: A, ddd.
5. THE PATTERN OF PIN 1 FIDUCIAL IS FOR REFERENCE ONLY.
6. THE TILT OF HEAT SINK SHOULD BE WITHIN 10MIL(0.254mm) (VERTICAL POSITION).

2.4 WBBGA144 Pin Number Order

Table 2-1 RK628D WBBGA144 Pin Number Order Information

Pin Name	Pin #	Pin Name	Pin #
VSS_1	A1	GVI/LVDS/MIPI_TX0N	G1
GVI/LVDS/MIPI_TX5P	A2	GVI/LVDS/MIPI_TX0P	G2
GVI/LVDS/MIPI_TX6P	A3	VSS_25	G3
GVI/LVDS/MIPI_TX7P	A4	VSS_19	G4
GVI/LVDS/MIPI_TX8P	A5	VSS_9	G5
GVI/LVDS/MIPI_TX9P	A6	VSS_13	G6
GPIO3_B1/GVI_HPD	A7	VSS_16	G7
GPIO3_A1/VOP_HSYNC	A8	VSS_20	G8
VOP_DCLK	A9	HDMIRX_EXTR	G9
GPIO2_C4/VOP_D20	A10	GPIO2_A0/VOP_D0	G10
GPIO2_C1/VOP_D17	A11	GPIO2_A1/VOP_D1	G11
VSS_2	A12	GPIO2_A2/VOP_D2	G12
GVI/LVDS/MIPI_REXT	B1	GPIO0_A7/I2S_D3_M0	H1
GVI/LVDS/MIPI_TX5N	B2	GPIO0_A6/I2S_D2_M0	H2
GVI/LVDS/MIPI_TX6N	B3	GPIO0_A5/I2S_D1_M0	H3
GVI/LVDS/MIPI_TX7N	B4	RESETN	H4
GVI/LVDS/MIPI_TX8N	B5	VCCIO1	H5
GVI/LVDS/MIPI_TX9N	B6	VSS_29	H6
GPIO3_B2/GVI_LOCK	B7	GPIO1_A0/TEST_CLKO	H7
GPIO3_A3/VOP_VSYNC	B8	GPIO1_A1	H8
GPIO3_A0/VOP_DEN	B9	HDMIRX_DVDD_1V1_1	H9
GPIO2_C3/VOP_D19	B10	VSS_18	H10
GPIO2_C0/VOP_D16	B11	HDMIRX_D2N	H11
GPIO2_B7/VOP_D15	B12	HDMIRX_D2P	H12
GVI/LVDS/MIPI_TX4N	C1	GPIO0_A3/I2S_LRCK_M0	J1
GVI/LVDS/MIPI_TX4P	C2	GPIO0_A2/I2S_SCK_M0	J2
GVI/LVDS/MIPI_PLL_AVDD_3V3	C3	INT/SPIBOOT	J3
VSS_26	C4	HDMITX_DVDD_1V1_2	J4
GVI/LVDS/MIPI_AVDD_1V1_3	C5	HDMITX_DVDD_1V1_3	J5
VSS_27	C6	HDMITX_DVDD_1V1_1	J6
I2C_ADDR	C7	PLL_AVDD_1V1	J7
GPIO2_C7/VOP_D23	C8	EFUSE_VDD_2V5	J8
GPIO2_C6/VOP_D22	C9	HDMIRX_DVDD_1V1_2	J9
GPIO2_C2/VOP_D18	C10	HDMIRX_AVDD_3V3_1	J10
GPIO2_B4/VOP_D12	C11	HDMIRX_D1N	J11
GPIO2_B6/VOP_D14	C12	HDMIRX_D1P	J12
GVI/LVDS/MIPI_TX3N	D1	GPIO0_B1/HDMITX_SDA	K1
GVI/LVDS/MIPI_TX3P	D2	GPIO0_A4/I2S_D0_M0	K2
VSS_5	D3	I2C_SDA	K3

Pin Name	Pin #	Pin Name	Pin #
GVI/LVDS/MIPI_AVDD_1V1_1	D4	HDMITX_AVDD_3V3	K4
GVI/LVDS/MIPI_AVDD_3V3_1	D5	VSS_7	K5
VSS_24	D6	VSS_22	K6
TEST	D7	VSS_10	K7
DVDD_2	D8	GPIO1_B0/HDMIRX_HPD_M0	K8
GPIO2_C5/VOP_D21	D9	GPIO1_B3/HDMIRX_CEC_M0	K9
GPIO2_B2/VOP_D10	D10	VSS_23	K10
GPIO2_B3/VOP_D11	D11	HDMIRX_D0N	K11
GPIO2_B5/VOP_D13	D12	HDMIRX_D0P	K12
GVI/LVDS/MIPI_TX2N	E1	GPIO0_B2/HDMITX_SCL	L1
GVI/LVDS/MIPI_TX2P	E2	GPIO0_B0/HDMITX_HPD	L2
GVI/LVDS/MIPI_AVDD_1V1_2	E3	I2C_SCL	L3
GVI/LVDS/MIPI_AVDD_3V3_2	E4	HDMITX_CLKN	L4
VSS_11	E5	HDMITX_D0N	L5
VSS_14	E6	HDMITX_D1N	L6
VSS_28	E7	HDMITX_D2N	L7
VCCIO2_1	E8	GPIO1_B2/HDMIRX_SCL_M0	L8
DVDD_1	E9	OSC_OUT	L9
GPIO2_A7/VOP_D7	E10	VSS_28	L10
GPIO2_B1/VOP_D9	E11	HDMIRX_CLKN	L11
GPIO2_B0/VOP_D8	E12	HDMIRX_CLKP	L12
GVI/LVDS/MIPI_TX1N	F1	VSS_4	M1
GVI/LVDS/MIPI_TX1P	F2	GPIO0_B3/HDMITX_CEC	M2
GVI/LVDS/MIPI_AVDD_1V1_4	F3	HDMITX_EXTR	M3
VSS_6	F4	HDMITX_CLKP	M4
VSS_8	F5	HDMITX_D0P	M5
VSS_12	F6	HDMITX_D1P	M6
VSS_15	F7	HDMITX_D2P	M7
VCCIO2_2	F8	GPIO1_B1/HDMIRX_SDA_M0	M8
GPIO2_A3/VOP_D3	F9	OSC_IN	M9
GPIO2_A6/VOP_D6	F10	PLL_AVDD	M10
GPIO2_A5/VOP_D5	F11	VSS_29	M11
GPIO2_A4/VOP_D4	F12	VSS_3	M12

2.5 WBBGA144 Ball Map

144	1	2	3	4	5	6	7	8	9	10	11	12	
A	VSS_1	GVI/LVDS/MIPI_TX5P	GVI/LVDS/MIPI_TX8P	GVI/LVDS/MIPI_TX7P	GVI/LVDS/MIPI_TX8P	GVI/LVDS/MIPI_TX9P	GPI03_B1/GVI_HPD	GPI03_A1/VOP_HSYN_C	VOP_DCLK	GPI02_C4/VOP_D20	GPI02_C1/VOP_D17	VSS_2	A
B	GVI/LVDS/MIPI_REXT	GVI/LVDS/MIPI_TX5N	GVI/LVDS/MIPI_TX8N	GVI/LVDS/MIPI_TX7N	GVI/LVDS/MIPI_TX8N	GVI/LVDS/MIPI_TX9N	GPI03_B2/GVI_LOCK	GPI03_A3/VOP_VSYN_C	GPI03_A0/VOP_DEN	GPI02_C3/VOP_D19	GPI02_C0/VOP_D16	GPI02_B7/VOP_D15	B
C	GVI/LVDS/MIPI_TX4N	GVI/LVDS/MIPI_TX4P	GVI/LVDS/MIPI_PLL_A_VDD_3V3	VSS_26	GVI/LVDS/MIPI_AVDD_1V1_3	VSS_27	I2C_ADDR	GPI02_C7/VOP_D23	GPI02_C6/VOP_D22	GPI02_C2/VOP_D18	GPI02_B4/VOP_D12	GPI02_B6/VOP_D14	C
D	GVI/LVDS/MIPI_TX3N	GVI/LVDS/MIPI_TX3P	VSS_5	GVI/LVDS/MIPI_AVDD_1V1_1	GVI/LVDS/MIPI_AVDD_3V3_1	VSS_24	TEST	DVDD_2	GPI02_C5/VOP_D21	GPI02_B2/VOP_D10	GPI02_B3/VOP_D11	GPI02_B5/VOP_D13	D
E	GVI/LVDS/MIPI_TX2N	GVI/LVDS/MIPI_TX2P	GVI/LVDS/MIPI_AVDD_1V1_2	GVI/LVDS/MIPI_AVDD_3V3_2	VSS_11	VSS_14	VSS_21	VCCIO2_1	DVDD_1	GPI02_A7/VOP_D7	GPI02_B1/VOP_D9	GPI02_B0/VOP_D8	E
F	GVI/LVDS/MIPI_TX1N	GVI/LVDS/MIPI_TX1P	GVI/LVDS/MIPI_AVDD_1V1_4	VSS_6	VSS_8	VSS_12	VSS_15	VCCIO2_2	GPI02_A3/VOP_D3	GPI02_A6/VOP_D6	GPI02_A5/VOP_D5	GPI02_A4/VOP_D4	F
G	GVI/LVDS/MIPI_TX0N	GVI/LVDS/MIPI_TX0P	VSS_25	VSS_19	VSS_9	VSS_13	VSS_16	VSS_20	HDMIRX_E_XTR	GPI02_A0/VOP_D0	GPI02_A1/VOP_D1	GPI02_A2/VOP_D2	G
H	GPI00_A7/2S_D3_M0	GPI00_A6/2S_D2_M0	GPI00_A5/2S_D1_M0	RESETN	VCCIO1	VSS_17	GPI01_A0/TEST_CLK0	GPI01_A1	HDMIRX_D_VDD_1V1_1	VSS_18	HDMIRX_D_2N	HDMIRX_D_2P	H
J	GPI00_A3/2S_LRCK_M0	GPI00_A2/2S_SCK_M0	GPI03_B4/NT	HDMITX_D_VDD_1V1_2	HDMITX_D_VDD_1V1_3	HDMITX_D_VDD_1V1_1	PLL_AVDD_1V1	EFUSE_VD_D_2V5	HDMIRX_D_VDD_1V1_2	HDMIRX_A_VDD_3V3_1	HDMIRX_D_1N	HDMIRX_D_1P	J
K	GPI00_B1/HDMITX_S_DA	GPI00_A4/2S_D0_M0	GPI01_B5/2CS_SDA	HDMITX_AVDD_3V3	VSS_7	VSS_22	VSS_10	GPI01_B0/HDMIRX_H_PD_M0	GPI01_B3/HDMIRX_C_EC_M0	VSS_23	HDMIRX_D_0N	HDMIRX_D_0P	K
L	GPI00_B2/HDMITX_S_CL	GPI00_B0/HDMITX_H_PD	GPI01_B4/2CS_SCL	HDMITX_CL_KN	HDMITX_D0_N	HDMITX_D1_N	HDMITX_D2_N	GPI01_B2/HDMIRX_S_CL_M0	OSC_OUT	VSS_28	HDMIRX_C_LKN	HDMIRX_C_LKP	L
M	VSS_4	GPI00_B3/HDMITX_C_EC	HDMITX_EXTR	HDMITX_CL_KP	HDMITX_D0_P	HDMITX_D1_P	HDMITX_D2_P	GPI01_B1/HDMIRX_S_DA_M0	OSC_IN	PLL_AVDD	VSS_29	VSS_3	M
	1	2	3	4	5	6	7	8	9	10	11	12	

Fig. 2-6 RK628D BGA144 Ball Map

2.6 Pin Description

In this chapter, the pin description will be divided into two parts, one is all power/ground descriptions in Table 2-2 for BGA144, include analog power/ground; another is all the function signals descriptions in Table 2-3, also include analog function signals.

2.7 RK628D Power/Ground IO Description

Table 2-2 RK628D Power/Ground IO Information for BGA628

Group	Ball#	Descriptions
VSS	A1,A12, C4,C6,D3,D6, E5,E6,E7, F4,F5,F6,F7, G3,G4,G5,G6,G7,G8 H6, H10, K5,K6,K7,K10, M1,M12,L10,M11	Ground
DVDD	D8,E9	Digital 1.1v power
VCCIO1	H5	IO1 3.3v power
VCCIO2	E8,F8	IO2 3.3v power
PLL_AVDD	M10	PLL 3.3v power
PLL_AVDD_1V1	J7	PLL 1.1v power

Group	Ball#	Descriptions
EFUSE_VDD_2V5	J8	EFUSE 2.5 power
GVI/LVDS/MIPI_PLL_AVDD_3V3	C3	TX PHY PLL Power
GVI/LVDS/MIPI_AVDD_3V3	D5,E4	TX PHY 3.3v Power
GVI/LVDS/MIPI_AVDD_1V1	C5,D4,E3,F3	TX PHY 1.1v Power
HDMITX_DVDD_1V1	J4,J5,J6	HDMI tx digital 1.1v power
HDMITX_AVDD_3V3	K4	HDMI tx analog 3.3v power
HDMIRX_DVDD_1V1	H9,J9	HDMI rx phy 1.1v power
HDMIRX_AVDD_3V3	J10	HDMI rx phy 3.3v power

2.8 RK628D Function IO Description

Table 2-3 RK628D Function IO Description

Pad#	Ball#	func1	func2	func3	Pad Type [®]	Drive Strength [®]	Pull	Reset State [®]	Power Supply
OSC_IN	M9				H	2	NA	I	
OSC_OUT	L9				H	2	NA	O	
RESETN	H4				B	2	Up	I	
TEST	D7				B	2	down	I	
I2C_ADDR	C7				B	4	down	I	
I2C_SCL	L3				G	4	up	I	
I2C_SDA	K3				G	4	up	I	
INT	J3				B	2	down	I	
GPIO0_A2/I2S_SCK_M0	J2	I2S_SCK_M0			D	12	down	I	
GPIO0_A3/I2S_LRCK_M0	J1	I2S_LRCK_M0			B	12	down	I	
GPIO0_A4/I2S_D0_M0	K2	I2S_D0_M0			B	12	down	I	
GPIO0_A5/I2S_D1_M0	H3	I2S_D1_M0			B	12	down	I	
GPIO0_A6/I2S_D2_M0	H2	I2S_D2_M0			B	12	down	I	
GPIO0_A7/I2S_D3_M0	H1	I2S_D3_M0			B	12	down	I	
GPIO0_B0/HDMITX_HPD	L2	HDMITX_HPD			E	4	down	I	
GPIO0_B1/HDMITX_SDA	K1	HDMITX_SDA			G	4	up	I	
GPIO0_B2/HDMITX_SCL	L1	HDMITX_SCL			G	4	up	I	
GPIO0_B3/HDMITX_CEC	M2	HDMITX_CEC			G	4	up	I	
GPIO1_A0/TEST_CLKO	H7	TEST_CLKO			B	4	down	I	
GPIO1_A1	H8				B	4	down	I	
GPIO1_B0/HDMIRX_HPD_M0	K8	HDMIRX_HPD_M0			F	4	up	I	
GPIO1_B1/HDMIRX_SDA_M0	M8	HDMIRX_SDA_M0			G	4	up	I	
GPIO1_B2/HDMIRX_SCL_M0	L8	HDMIRX_SCL_M0			G	4	up	I	
GPIO1_B3/HDMIRX_CEC_M0	K9	HDMIRX_CEC_M0			G	4	up	I	
GPIO2_A0/VOP_D0	G10	VOP_D0			I	6/13/20/27	down	I	GPIO
GPIO2_A1/VOP_D1	G11	VOP_D1			I	6/13/20/27	down	I	
GPIO2_A2/VOP_D2	G12	VOP_D2			I	6/13/20/27	down	I	
GPIO2_A3/VOP_D3	F9	VOP_D3			I	6/13/20/27	down	I	
GPIO2_A4/VOP_D4	F12	VOP_D4			I	6/13/20/27	down	I	
GPIO2_A5/VOP_D5	F11	VOP_D5			I	6/13/20/27	down	I	
GPIO2_A6/VOP_D6	F10	VOP_D6			I	6/13/20/27	down	I	
GPIO2_A7/VOP_D7	E10	VOP_D7			I	6/13/20/27	down	I	
GPIO2_B0/VOP_D8	E12	VOP_D8			I	6/13/20/27	down	I	
GPIO2_B1/VOP_D9	E11	VOP_D9			I	6/13/20/27	down	I	
GPIO2_B2/VOP_D10	D10	VOP_D10			I	6/13/20/27	down	I	
GPIO2_B3/VOP_D11	D11	VOP_D11			I	6/13/20/27	down	I	
GPIO2_B4/VOP_D12	C11	VOP_D12			I	6/13/20/27	down	I	
GPIO2_B5/VOP_D13	D12	VOP_D13			I	6/13/20/27	down	I	
GPIO2_B6/VOP_D14	C12	VOP_D14			I	6/13/20/27	down	I	

Pad#	Ball#	func1	func2	func3	Pad Type [®]	Drive Strength [®]	Pull	Reset State [®]	Power Supply
GPIO2_B7/VOP_D15	B12	VOP_D15			I	6/13/20/27	down	I	Power Supply
GPIO2_C0/VOP_D16	B11	VOP_D16			I	6/13/20/27	down	I	
GPIO2_C1/VOP_D17	A11	VOP_D17			I	6/13/20/27	down	I	
GPIO2_C2/VOP_D18	C10	VOP_D18			I	6/13/20/27	down	I	
GPIO2_C3/VOP_D19	B10	VOP_D19			I	6/13/20/27	down	I	
GPIO2_C4/VOP_D20	A10	VOP_D20			I	6/13/20/27	down	I	
GPIO2_C5/VOP_D21	D9	VOP_D21			I	6/13/20/27	down	I	
GPIO2_C6/VOP_D22	C9	VOP_D22			I	6/13/20/27	down	I	
GPIO2_C7/VOP_D23	C8	VOP_D23			I	6/13/20/27	down	I	
VOP_DCLK	A9	VOP_DCLK			I	6/13/20/27	down	I	
GPIO3_A0/VOP_DEN	B9	VOP_DEN			I	6/13/20/27	down	I	
GPIO3_A1/VOP_HSYNC	A8	VOP_HSYNC			I	6/13/20/27	down	I	
GPIO3_A3/VOP_VSYNC	B8	VOP_VSYNC			I	6/13/20/27	down	I	
GPIO3_B1/GVI_HPD	A7	GVI_HPD			C	4	up	I	
GPIO3_B2/GVI_LOCK	B7	GVI_LOCK			C	4	up	I	
HDMIRX_EXTR	G9				A	NA	NA	NA	HDMI
HDMIRX_CLKN	L11				A	NA	NA	NA	
HDMIRX_CLKP	L12				A	NA	NA	NA	
HDMIRX_D0N	K11				A	NA	NA	NA	
HDMIRX_D0P	K12				A	NA	NA	NA	
HDMIRX_D1N	J11				A	NA	NA	NA	
HDMIRX_D1P	J12				A	NA	NA	NA	
HDMIRX_D2N	H11				A	NA	NA	NA	
HDMIRX_D2P	H12				A	NA	NA	NA	
HDMITX_CLKN	L4				A	NA	NA	NA	HDMITX
HDMITX_CLKP	M4				A	NA	NA	NA	
HDMITX_D0N	L5				A	NA	NA	NA	
HDMITX_D0P	M5				A	NA	NA	NA	
HDMITX_D1N	L6				A	NA	NA	NA	
HDMITX_D1P	M6				A	NA	NA	NA	
HDMITX_D2N	L7				A	NA	NA	NA	
HDMITX_D2P	M7				A	NA	NA	NA	
HDMITX_EXTR	M3				A	NA	NA	NA	
GVI/LVDS/MIPI_REXT	B1				A	NA	NA	NA	GVI/LVD S/MIPI_T X
GVI/LVDS/MIPI_TX0N	G1				A	NA	NA	NA	
GVI/LVDS/MIPI_TX0P	G2				A	NA	NA	NA	
GVI/LVDS/MIPI_TX1N	F1				A	NA	NA	NA	
GVI/LVDS/MIPI_TX1P	F2				A	NA	NA	NA	
GVI/LVDS/MIPI_TX2N	E1				A	NA	NA	NA	
GVI/LVDS/MIPI_TX2P	E2				A	NA	NA	NA	
GVI/LVDS/MIPI_TX3N	D1				A	NA	NA	NA	
GVI/LVDS/MIPI_TX3P	D2				A	NA	NA	NA	
GVI/LVDS/MIPI_TX4N	C1				A	NA	NA	NA	
GVI/LVDS/MIPI_TX4P	C2				A	NA	NA	NA	
GVI/LVDS/MIPI_TX5N	B2				A	NA	NA	NA	
GVI/LVDS/MIPI_TX5P	A2				A	NA	NA	NA	
GVI/LVDS/MIPI_TX6N	B3				A	NA	NA	NA	
GVI/LVDS/MIPI_TX6P	A3				A	NA	NA	NA	
GVI/LVDS/MIPI_TX7N	B4				A	NA	NA	NA	
GVI/LVDS/MIPI_TX7P	A4				A	NA	NA	NA	
GVI/LVDS/MIPI_TX8N	B5				A	NA	NA	NA	
GVI/LVDS/MIPI_TX8P	A5				A	NA	NA	NA	
GVI/LVDS/MIPI_TX9N	B6				A	NA	NA	NA	
GVI/LVDS/MIPI_TX9P	A6				A	NA	NA	NA	

Notes:

- ① Pad types: I = input, O = output, I/O = input/output (bidirectional)
 AP = Analog Power, AG = Analog Ground
 DP = Digital Power, DG = Digital Ground
 A = Analog

② Output Drive Unit is mA, only Digital IO has drive value;

③ Reset state: I = input without any pull resistor, O = output without any pull resistor;

2.9 IO Pin Name Description

This sub-chapter will focus on the detailed function description of every pins based on different interface.

Table 2-4 RK628D IO Function Description List

Interface	Pin Name	Direction	Description
MISC	XIN_OSC	I	Clock input of 24MHz crystal
	XOUT_OSC	O	Clock output of 24MHz crystal
	NPOR	I	Chip hardware reset

Interface	Pin Name	Direction	Description
GVI/LVDS/MIPI_TX	GVI/LVDS/MIPI_REXT	I	External reference resistor
	GVI/LVDS/MIPI_TXiN(i=0~9)	O	GVI/LVDS/MIPI Tx negative differential line driver data output
	GVI/LVDS/MIPI_TXiP(i=0~9)	O	GVI/LVDS/MIPI Tx positive differential line driver data output

Interface	Pin Name	Direction	Description
HDMI_RX	HDMIRX_EXTR	I	External reference resistor
	HDMIRX_CLKN	I	HDMI clk lane N
	HDMIRX_CLKP	I	HDMI clk lane P
	HDMIRX_D0N	I	HDMI data lane 0
	HDMIRX_D0P	I	HDMI data lane 0
	HDMIRX_D1N	I	HDMI data lane 1
	HDMIRX_D1P	I	HDMI data lane 1
	HDMIRX_D2N	I	HDMI data lane 2
HDMIRX_D2P	I	HDMI data lane 2	

Interface	Pin Name	Direction	Description
HDMI_TX	HDMITX_CLKN	O	HDMI negative TMDS differential line driver clock output.
	HDMITX_CLKP	O	HDMI positive TMDS differential line driver clock output.
	HDMITX_DiN(i=0~2)	O	HDMI negative TMDS differential line driver data output.
	HDMITX_DiP(i=0~2)	O	HDMI positive TMDS differential line driver data output.
	HDMITX_EXTR	I	HDMI reference resistor

Interface	Pin Name	Direction	Description
PARALLEL	VOP_DCLK	I/O	Parallel dclk signal
	GPIO3_A0/VOP_DEN	I/O	Parallel data enable signal
	GPIO3_A1/VOP_HSYNC	I/O	Parallel hsync signal
	GPIO3_A3/VOP_VSYNC	I/O	Parallel vsync signal
	GPIO2_A0/VOP_D0~ GPIO2_C7/VOP_D23	I/O	Parallel data 0~23

2.10 RK628D IO Type

The following list shows IO type except Analog IO and all of Power/Ground IO.

Table 2-5 RK628D IO Type List

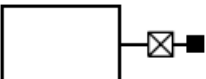
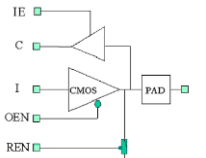
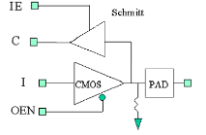
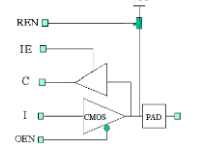
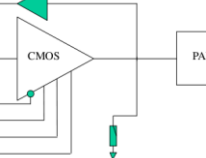
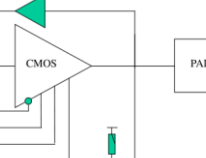
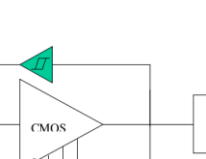
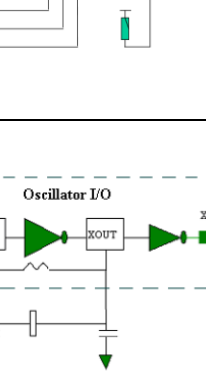
Type	Diagram	Description	sample
A		Analog IO Cell with IO Voltage	EFUSE
B		3-state output pad with enable controlled input and enable controlled pull-down	GPIO0_A3/I2S_LRCK_M0
C		3-state output pad with enable controlled Schmitt trigger input and pull-down	GPIO0_A2/I2S_SCK_M0
D		3-state output pad with enable controlled input and enable controlled pull-up	GPIO3_B1/GVI_HPDP
E		3-state bi-direction I/O pads with controlled driving strength of low level, slew rate and uncontrolled pull-down resistor	GPIO0_B0/HDMITX_HPDP
F		3-state bi-direction I/O pads with controlled driving strength of low level, slew rate and uncontrolled pull-up resistor	GPIO0_B1/HDMITX_SDA
G		3-state bi-direction I/O pads with controlled driving strength of low level, slew rate and uncontrolled Schmitt trigger, pull-up resistor	GPIO1_B0/HDMIRX_HPDP_M0
H		CRYSTAL OSCILLATOR WITH INTERNAL RESISTOR	OSC_IN OSC_OUT

Type	Diagram	Description	sample
I		<p>3-state bi-direction I/O pads with programmable drive-strength, controlled input enable, Schmitt trigger and pull-up / pull-down resistor</p>	<p>GPIO2_A0~2_C7/VOP_D0~23</p>

Chapter 3 Electrical Specification

3.1 Absolute Maximum Ratings

Table 3-1 RK628D Absolute Maximum Ratings

Parameters	Related Power Group	Max	Unit
DC supply voltage for internal digital logic@1.1v	DVDD_1,DVDD_2	1.3	V
DC supply voltage for digital GPIO@1.8V mode	VCCIO2_1	2.3	V
	VCCIO2_2	2.3	
DC supply voltage for digital GPIO@3.3V mode	VCCIO1	3.8	V
	VCCIO2_1	3.8	
	VCCIO2_2	3.8	
DC supply voltage for HDMI RX	HDMIRX_AVDD_3V3	3.8	V
	HDMIRX_DVDD_1V1	1.3	
DC supply voltage for GVI/LVDS/MIPI TX	GVI/LVDS/MIPI_PLL_AVDD_3V3	3.8	V
	GVI/LVDS/MIPI_AVDD_3V3	3.8	
	GVI/LVDS/MIPI_AVDD_1V1	1.3	
DC supply voltage for HDMI TX	HDMITX_DVDD_1V1	1.3	V
	HDMITX_AVDD_3V3	3.8	
DC supply voltage for PLL	PLL_AVDD_1V1	1.3	V
	PLL_AVDD_3V3	3.8	
DC supply voltage for EFUSE	EFUSE_VDD_2V5	2.75	V
Storage Temperature	Tstg	125	°C
Max Conjunction Temperature	Tj	125	°C

Absolute maximum ratings specify the values beyond which the device may be damaged permanently. Long-term exposure to absolute maximum ratings conditions may affect device reliability.

3.2 Recommended Operating Condition

Following table describes the recommended operating condition.

Table 3-2 RK628D Recommended Operating Condition

Parameters	Symbol	Min	Type	Max	Unit
DC supply voltage for internal digital logic@1.1v	DVDD_1,DVDD_2	0.99	1.1	1.21	V
DC supply voltage for digital GPIO@1.8V mode	VCCIO2_1	1.62	1.8	1.98	V
	VCCIO2_2	1.62	1.8	1.98	
DC supply voltage for digital GPIO@3.3V mode	VCCIO1	3.135	3.3	3.465	V
	VCCIO2_1	3.135	3.3	3.465	
	VCCIO2_2	3.135	3.3	3.465	
DC supply voltage for HDMI RX	HDMIRX_AVDD_3V3	3.135	3.3	3.465	V
	HDMIRX_DVDD_1V1	0.99	1.1	1.21	
DC supply voltage for GVI/LVDS/MIPI TX	GVI/LVDS/MIPI_PLL_AVDD_3V3	3.135	3.3	3.465	V
	GVI/LVDS/MIPI_AVDD_3V3	3.135	3.3	3.465	
	GVI/LVDS/MIPI_AVDD_1V1	0.99	1.1	1.21	
DC supply voltage for HDMI TX	HDMITX_AVDD_3V3	3.135	3.3	3.465	V
	HDMITX_DVDD_1V1	0.99	1.1	1.21	
DC supply voltage for PLL	PLL_AVDD_3V3	3.135	3.3	3.465	V
	PLL_AVDD_1V1	0.99	1.1	1.21	
DC supply voltage for EFUSE	EFUSE_VDD_2V5	2.375	2.5	2.625	V
PLL input clock frequency		N/A	24	N/A	MHz
Operating Temperature		-40	25	125	°C

3.3 DC Characteristics

Table 3-3 RK628D DC Characteristics

Parameters	Symbol	Min	Typ	Max	Units	
Digital GPIO @3.3V for GPIO0/1/2/3	Input Low Voltage	Vil	-0.3	NA	0.8	V
	Input High Voltage	Vih	2.0	NA	3.465	V
	Output Low Voltage	Vol	NA	NA	0.4	V
	Output High Voltage	Voh	2.4	NA	NA	V
	Threshold Point	Vtr+	1	1.16	1.34	V
Vtr-		1.02	1.19	1.39	V	

Parameters		Symbol	Min	Typ	Max	Units
	Pullup Resistor	Rpu	26	46	71	Kohm
	Pulldown Resistor	Rpd	27	48	102	Kohm
Digital GPIO @1.8V for GPIO0/1/2/3	Input Low Voltage	Vil	-0.3	NA	0.58	V
	Input High Voltage	Vih	1.27	NA	3.15	V
	Output Low Voltage	Vol	NA	NA	0.45	V
	Output High Voltage	Voh	1.40	NA	NA	V
	Threshold Point	Vtr+	0.9	0.95	1.01	V
		Vtr-	0.91	0.97	1.03	V
	Pullup Resistor	Rpu	33	58	88	Kohm
	Pulldown Resistor	Rpd	34	60	93	Kohm

3.4 Recommended Operating Frequency

Table 3-4 RK628D Recommended Operating Frequency

Parameter	Condition	Symbol	Min	Typ	Max	Unit
CPLL	0.9V , 25 °C	cpll				MHz
	0.99V , -40 °C					
	0.81V , 125 °C				1600	
GPLL	0.9V , 25 °C	gppll				MHz
	0.99V , -40 °C					
	0.81V , 125 °C				1600	
HDMI RX CTRL	0.9V , 25 °C	dclk_rx				MHz
	0.99V , -40 °C					
	0.81V , 125 °C				375	
Process	0.9V , 25 °C	sclk				MHz
	0.99V , -40 °C					
	0.81V , 125 °C				600	