

TO-220 Plastic-Encapsulate Transistors

TIP127 TRANSISTOR (PNP)

: 95HI F9G

- High DC Current Gain
- Electrically Similar to Popular TIP127
- Built-in a Damper Diode at E-C

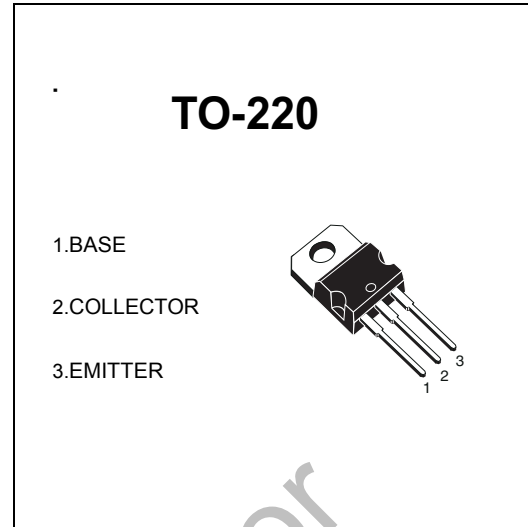

A5L-AI A F5HB; G (Ta=25°C unless otherwise noted)

Gna Vc	DUFUa Yhf	JUj Y	I bjh
J76C	Collector-Base Voltage	100	V
J79C	Collector-Emitter Voltage	100	V
J96C	Emitter-Base Voltage	5	V
7	Collector Current -Continuous	5	A
D7	Collector Dissipation	2	W
HZHgt	Junction and Storage Temperature	-55-150	°C

9 @ 7 HF 7 5 @ 7 < 5 F 5 7 H 9 F - G H 7 G (H1 &) °Ci b Ygg ch Yfk jgY gdYVZ YX

DUFUa Yhf	Gna Vc	HYgh WcbX]hc b g	A]b	Hnd	A U	I bjh
7c YWcf!VUgY VfYU_Xck b'j c`HU Y	V _{(BR)CBO}	I _C =1mA, I _E =0	100			V
7c YWcf!Ya]Hf VfYU_Xck b'j c`HU Y	V _{(BR)CEO}	I _C =30mA, I _B =0	100			V
9a]Hf!VUgY VfYU_Xck b'j c`HU Y	V _{(BR)EBO}	I _E =3mA, I _C =0	5			V
7c YWcf W HcZw ffYbh	I _{CBO}	V _{CB} =100V, I _E =0			10	µA
7c YWcf!Ya]Hf W HcZw ffYbh	I _{CEO}	V _{CE} =50V, I _E =0			10	µA
9a]Hf W HcZw ffYbh	I _{EBO}	V _{EB} =5V, I _C =0			2	mA
87 W ffYbh[U]b	h _{FE(2)}	V _{CE} =4V, I _C =4A	1000		10000	
	h _{FE(3)}	V _{CE} =4V, I _C =8A	100			
7c YWcf!Ya]Hf gU] fU]cb'j c`HU Y	V _{CE(sat)(1)}	I _C =4A, I _B =16mA			2	V
	V _{CE(sat)(2)}	I _C =8A, I _B =80mA			4	V
6 UgY!Ya]Hf gU] fU]cb'j c`HU Y	V _{BE(sat)}	I _C =8A, I _B =80mA			4.5	V
6 UgY!Ya]Hf j c`HU Y*	V _{BE}	V _{CE} =4V, I _C =4A			2.8	V
7c YWcf ci hdi hVUdU]hU]bW	C _{ob}	V _{CB} =10V, I _E =0, f=0.1MHz			200	pF