

This document is the property of Amphenol Corporation and is delivered on the express condition that is not to be disclosed, reproduced or used, in whole or in part, for manufacture or sale by anyone other than Amphenol Corporation without its prior consent, and that no right is granted to disclose or to use any information in this document.

The marking on this product doesn't contain environmental hazardous materials per Material Specification SS-00259 for Sony GP compliant or per directive 2011/65/EU for RoHS compliant or per IEC 61249-2-21 for Halogen-Free compliant.

REVISIONS				
SYM	ECN No.	DESCRIPTION	DATE	BY
AX1	NA	INITIAL REVISION	02/21/2019	JOAN LU
AX2	NA	REVISED DRAWING	06/11/2019	JOAN LU

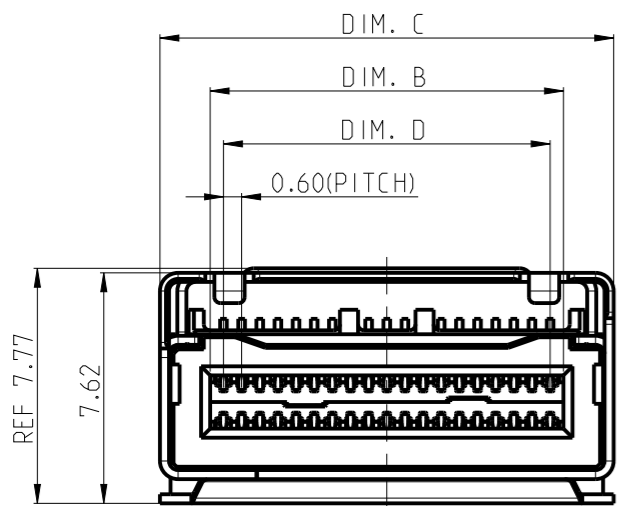

FOR REFERENCE ONLY

- G98 V X X X X X X HR
- MINI COOL EDGE IO INTEGRATED CONNECTOR
- VERTICAL TYPE
- CONNECTOR SPEED
1 : PAM4 56G, 950HM
- CHANNEL/PIN QTY
1: 4X/38P
5: 8X/50P
- CONTACT FINISH
2: 15u" GOLD
3: 30u" GOLD
- COMPLIANT CODE
HR: HALOGEN-FREE & RoHS
- VARIATION CODE
BLANK: STANDARD
- PACKING CODE
2: TAPE AND REEL(WITH CAP)
- SHELL PIN LENGTH OPTION(DIM.A)
1: 1.50mm
2: 2.20mm
3: 3.00mm
4: 4.20mm

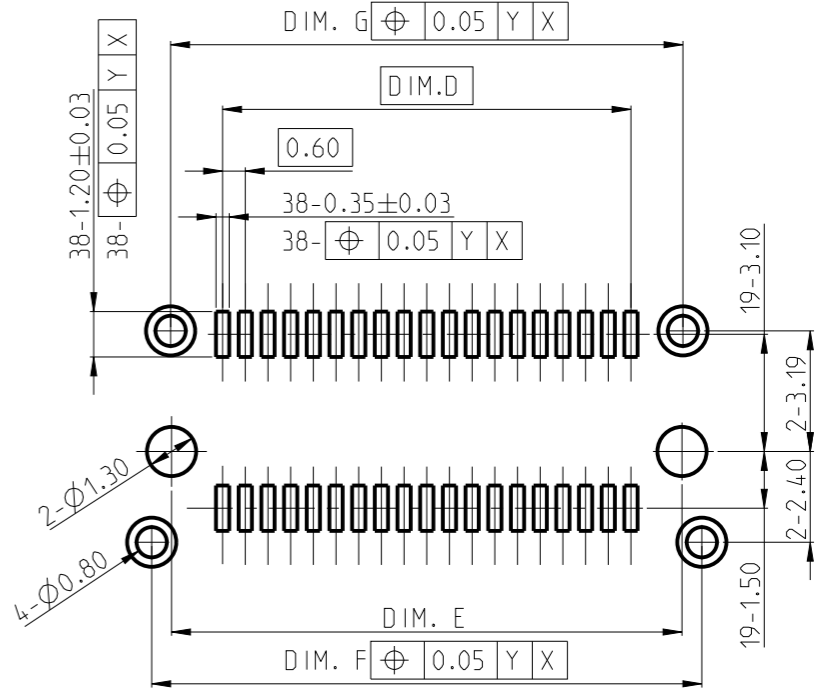
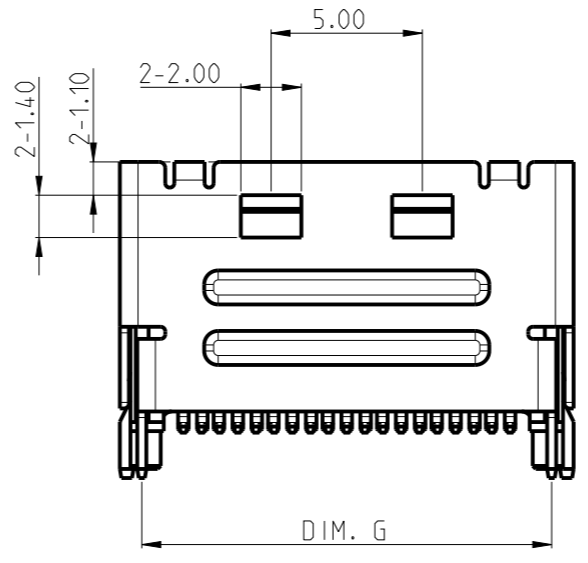
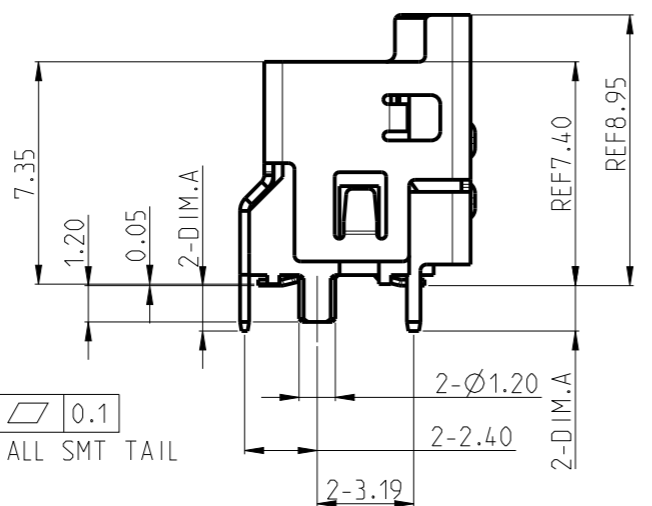
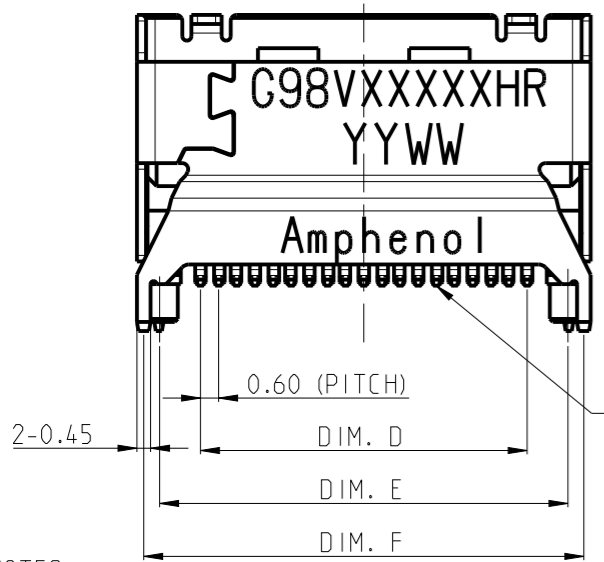

RECOMMENDED PCB LAYOUT
(GENERAL TOLERANCES : +/-0.05)

NOTES:
1. MATERIALS:
PLASTICS : HIGH TEMPERATURE THERMOPLASTIC UL94-0,COLOR: NATURAL
SHELL : STAINLESS
CONTACT: COPPER ALLOY
2: FINISH
TERMINAL : CONTACT AREA : SELECTED GOLD PLATING.
SOLDER AREA : MATTE TIN PLATING 100u"
UNDER PLATING: NICKEL PLATING 50u"MIN OVER ALL
SHELL : UNDER PLATING: ELECTROLESS NICKEL PLATING 50u"MIN OVER ALL
3.THIS PRODUCT DOESN'T CONTAIN ENVIROMENTAL HAZARDOUS MATERIALS PER DERCTIVE 2011/65/EC FOR RoHS AND PER IEC 61249-2-21 FOR HALOGEN FREE.



PART NUMBER	POS. (N)	DIM. B	DIM. C	DIM. D	DIM. E	DIM. F	DIM. G
G98VX1XXXXHR	38	11.68	15.00	10.80	13.50	14.55	13.55
G98VX5XXXXHR	50	15.28	18.60	14.40	17.10	18.15	17.15

TOLERANCE	DRAWN	APPROVALS	DATE
X.	DESIGNED	Joan Lu	06/11/2019
X.X ±0.30	CHECKED	Sondra Sang	06/11/2019
X.XX ±0.20	APPROVED	Hank Hsu	06/11/2019
X.XXX ±0.10	DWG TYPE	CUST DWG	PROJECT CODE TXXX
ANGULAR ±2°	UNLESS OTHERWISE SPECIFIED		

TITLE
MINI COOL EDGE IO INTEGRATED CONNECTOR
0.6 PITCH, VERTICAL
STANDARD. SMT TYPE

UNIT mm SIZE A3
SCALE NA SHEET 1 OF 1

Amphenol®
Amphenol Corporation
Amphenol Taiwan Corporation

PART No. **G98VXXXXXXHR**
DWG No. G98VXXXXXXHR
REV. AX2

This document is the property of Amphenol Corporation and is delivered on the express condition that it is not to be disclosed, reproduced or used, in whole or in part, for manufacture or sale by anyone other than Amphenol Corporation without its prior consent, and that no right is granted to disclose or to use any information in this document.

The marking on this product doesn't contain environmental hazardous materials per Material Specification SS-00259 for Sony GP compliant or per directive 2011/65/EU for RoHS compliant or per IEC 61249-2-21 for Halogen-Free compliant.

REVISIONS				
SYM	ECN No.	DESCRIPTION	DATE	BY
AX1	NA	INITIAL REVISION	02/21/2019	JOAN LU
AX2	NA	REVISED DRAWING	06/11/2019	JOAN LU

FOR REFERENCE ONLY

G98VX1XXXHR

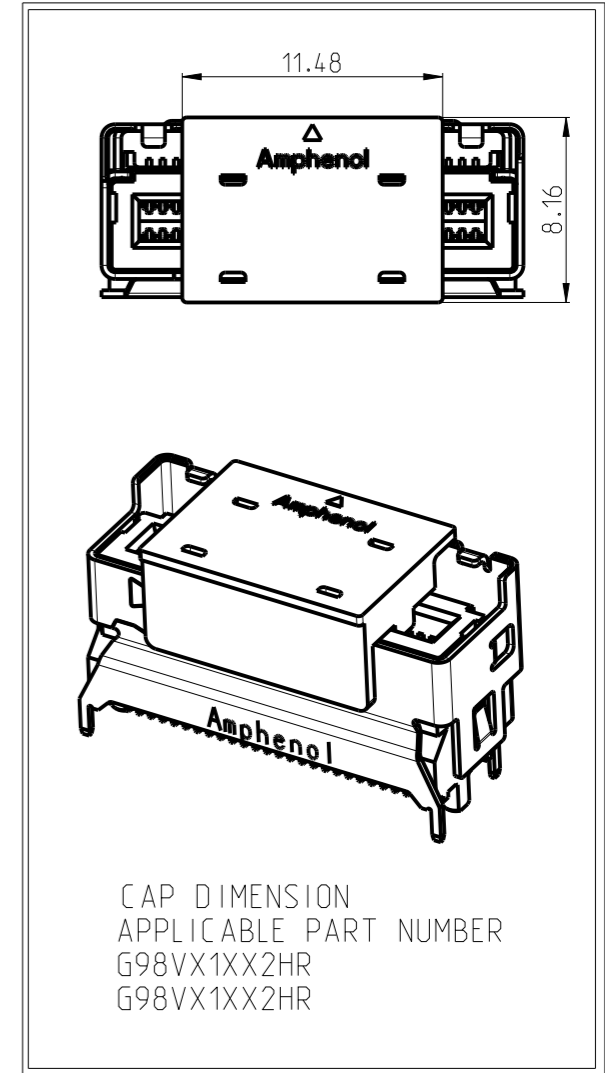
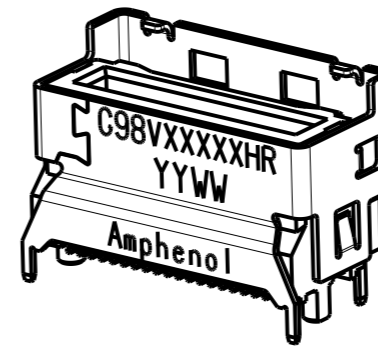
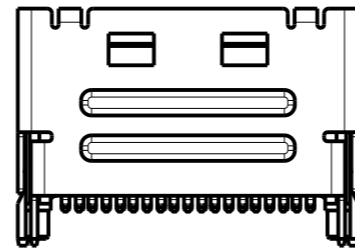
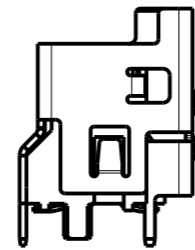
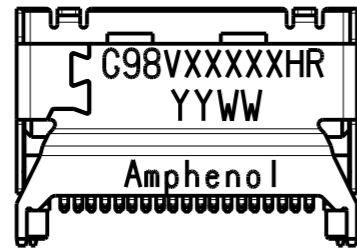

G98VX1XXXHR

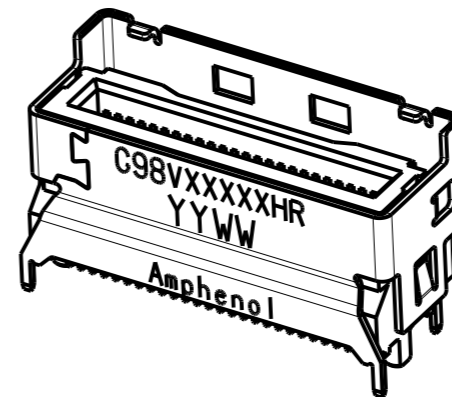
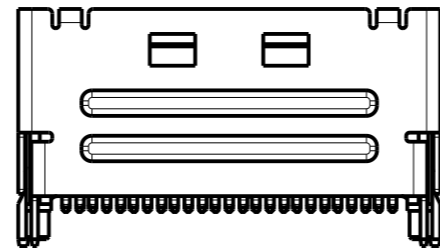
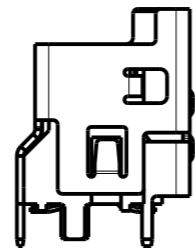
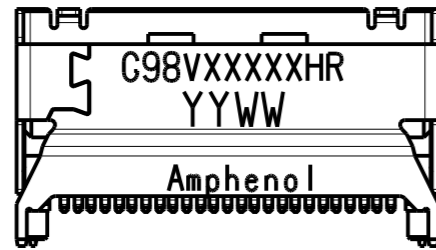

TOLERANCE	DRAWN APPROVALS	DATE	TITLE MINI COOL EDGE IO INTEGRATED CONNECTOR 0.6 PITCH, VERTICAL STANDARD. SMT TYPE				Amphenol® Amphenol Corporation Amphenol Taiwan Corporation	
X. X.X ±0.30 X.XX ±0.20 X.XXX ±0.10	DESIGNED Joan Lu	06/11/2019	UNIT mm	SIZE A3	PART No. G98VXXXXXHR			
ANGULAR ±2°	CHECKED Sondra Sang	06/11/2019	SCALE NA	SHEET 2 OF 2	DWG No. G98VXXXXXHR		REV. AX2	
UNLESS OTHERWISE SPECIFIED	DWG TYPE CUST DWG	PROJECT CODE TXXX						