

REVISIONS				
REV.	ECO. NO	DESCRIPTION	DATE	BY
A	1790	INITIAL RELEASE	8/22/2008	ASK
B	3181	UPDATE DWG FORMAT	3/16/2015	MG

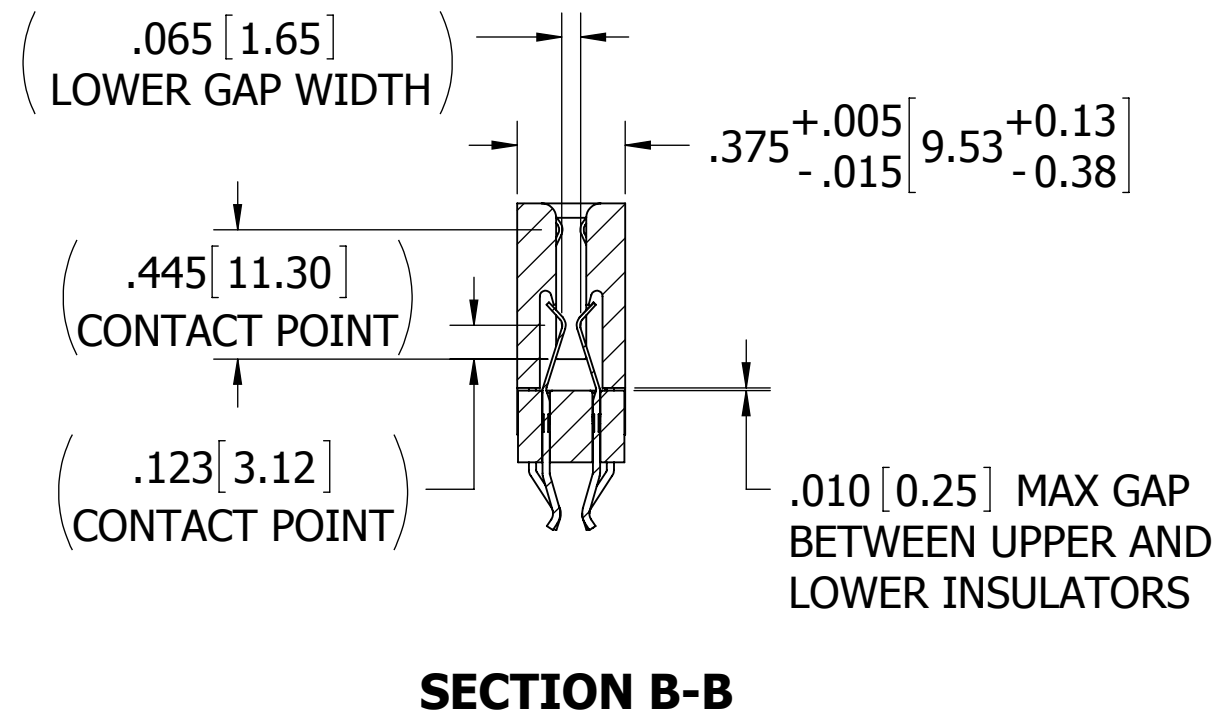

- NOTES:
- INSULATOR MATERIAL: SEE PART NUMBER CODING
  - CONTACT MATERIAL: SEE PART NUMBER CODING
  - PLATING: SEE PART NUMBER CODING
  - OPERATING TEMPERATURE: SEE PART NUMBER CODING
  - PROCESSING TEMP: SEE PART NUMBER CODING
  - UL FLAMMABILITY RATING: 94V-0
  - OPERATING VOLTAGE: 225 VAC MINIMUM AT SEA LEVEL
  - CURRENT RATING: 3 AMP
  - CONTACT RESISTANCE: 30 MILLI OHMS MAX
  - INSULATION RESISTANCE: 5000 MEGA OHMS
  - DURABILITY: 500 CYCLES MIN
  - CONNECTOR IDENTIFICATION: THE PART SHALL BE MARKED WITH A PART NUMBER AND LOT CODE
  - BOARD THICKNESS ACCOMMODATED: .093 ± .008 [2.36 ± 0.20]
  - INSERTION FORCE: 16 OZ MAX PER CONTACT PAIR WHEN USING A .093 [2.36] TEST BLADE  
INTERNAL INSPECTION TO BE PER SULLINS WORK INSTRUCTION WI7.3-01
  - WITHDRAWAL FORCE: 1 OZ MIN PER CONTACT PAIR USING .093 [2.36] PCB
  - MODIFICATION: CARD EXTENDER BEND TO ACCEPCT .093 [2.36] PCB; FOR .093" DAUGHTER CARD

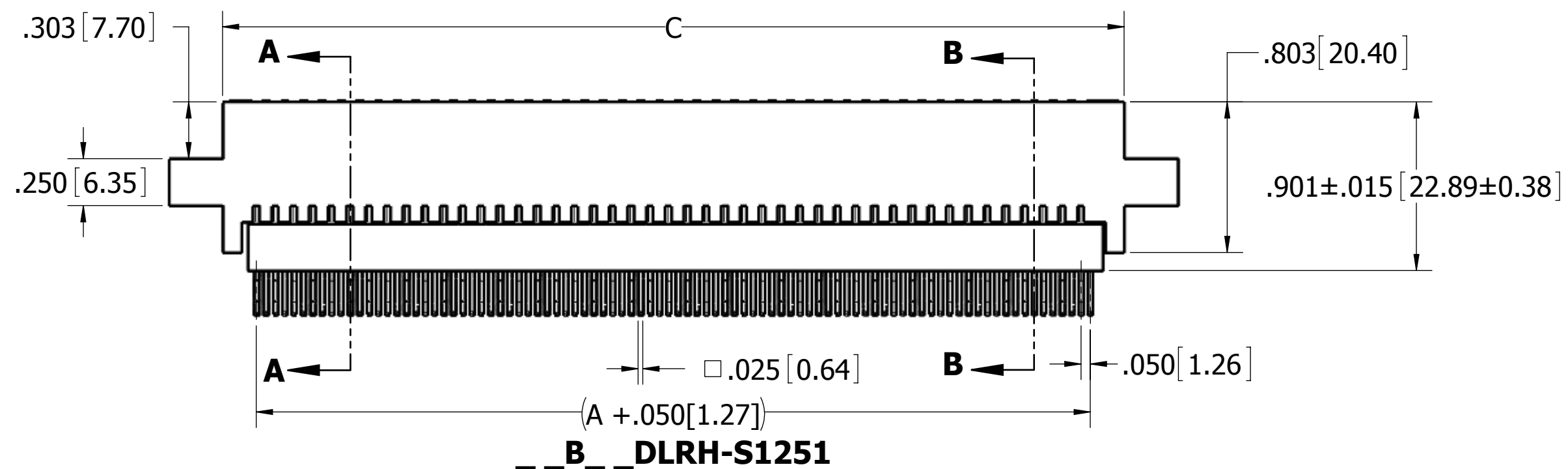
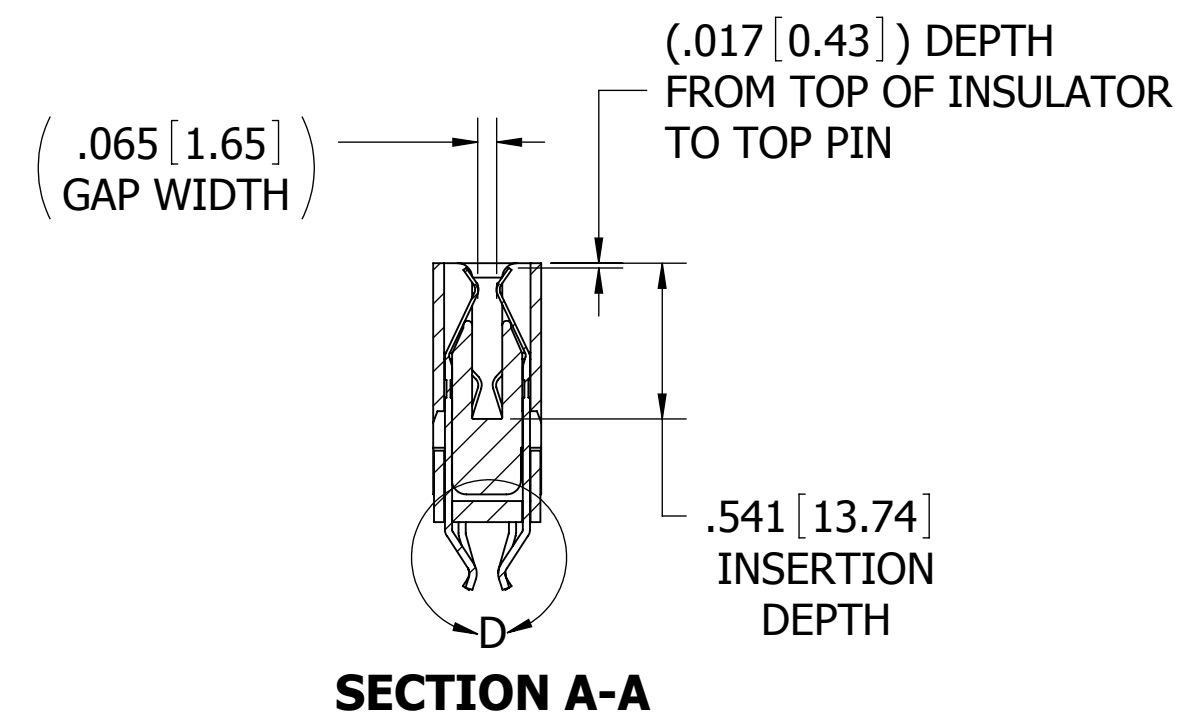
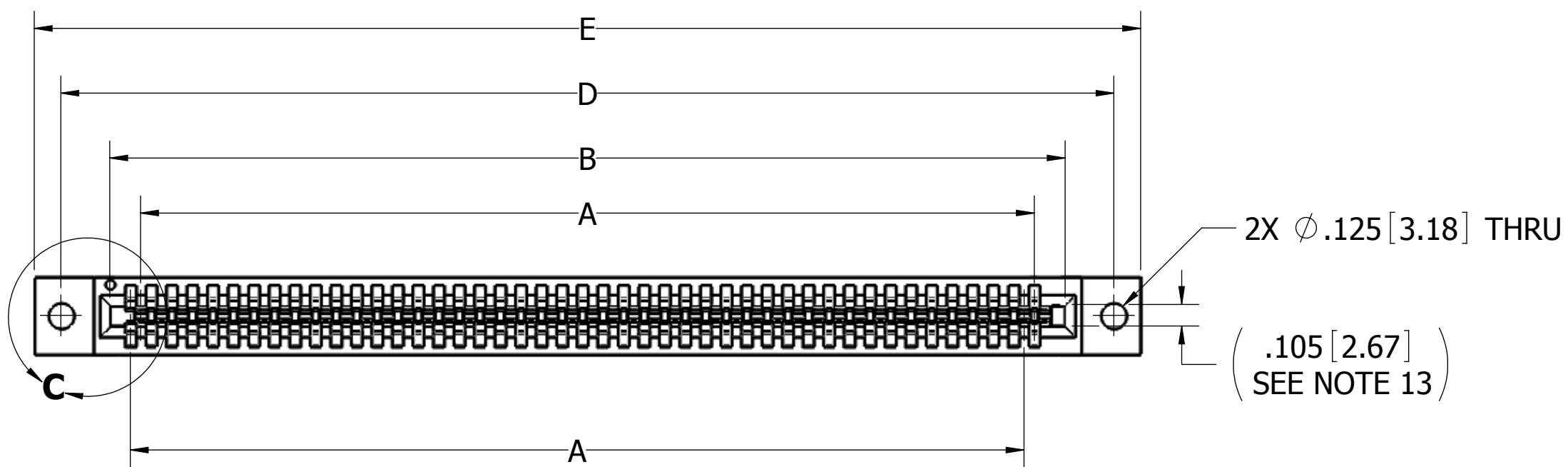

**CUSTOMER COPY**

UNLESS OTHERWISE SPECIFIED: DIMENSIONS ARE IN INCHES [MM]		DRAWN	DATE	NAME	
			8/22/2008	ASK	
TOLERANCES:					<small>THE INFORMATION HEREIN CONTAINS PROPRIETARY INFORMATION OF SULLINS ELECTRONICS AND IS NOT TO BE REPRODUCED, USED OR DISCLOSED TO OTHERS FOR ANY PURPOSE EXCEPT AS SPECIFICALLY AUTHORIZED IN WRITING BY AN OFFICER OF SULLINS ELECTRONICS.</small>
ANGULAR: ± 1°					
DECIMALS .XX = ± .02 [.5] .XXX = ± .005 [.13] .XXXX = ± .0005 [.013]					
		TITLE			BI-LEVEL, .050 CC, .093 PCB, CE
		PART NUMBER			__B__DLR__S1251
SIZE	CAGE CODE	DWG. NO.		REV	
C	54453	C11140		B	
SCALE: 3:2		SHEET 1 OF 4			

8 7 6 5 4 3 2 1

F  
E  
D  
C  
B  
A

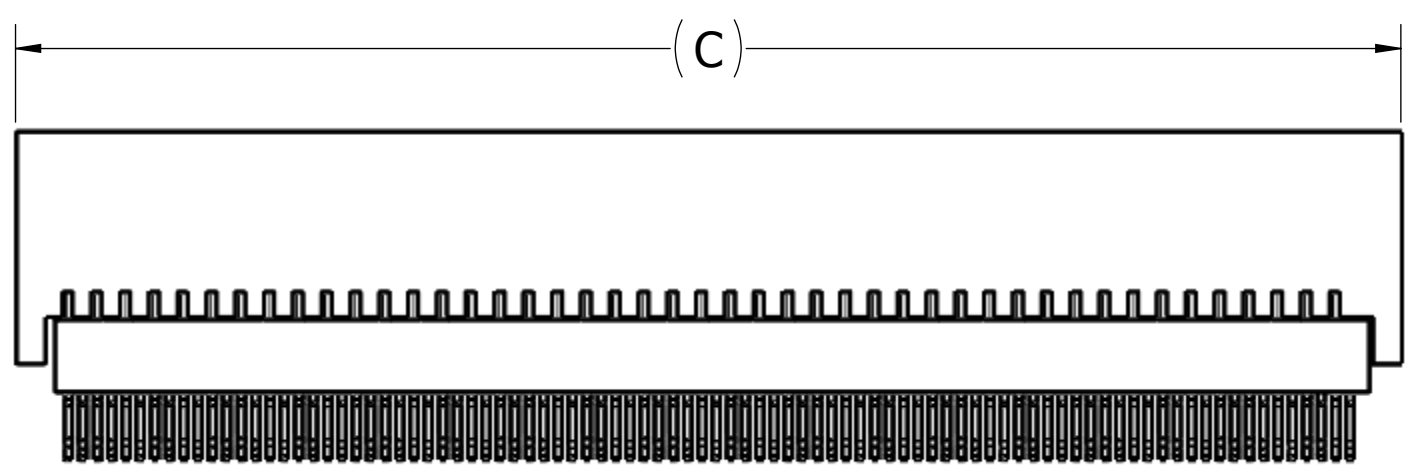
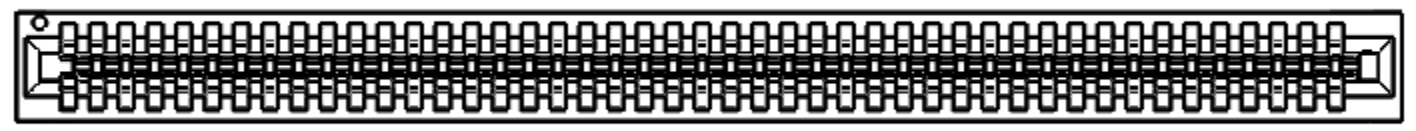

**--B--DLRN-S1251**

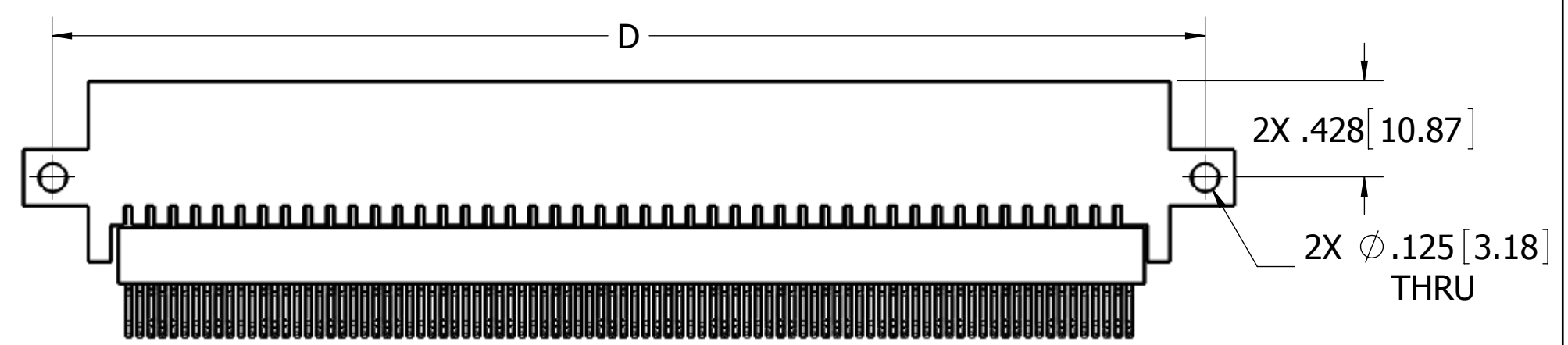
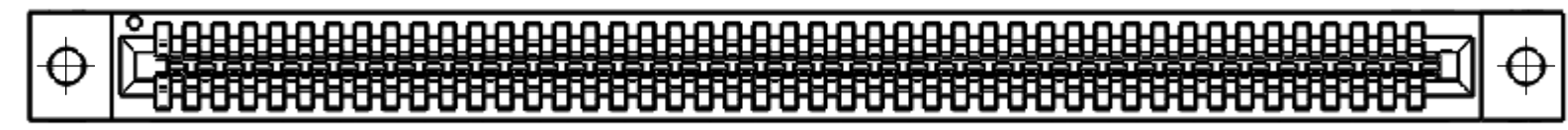

**--B--DLRS-S1251**

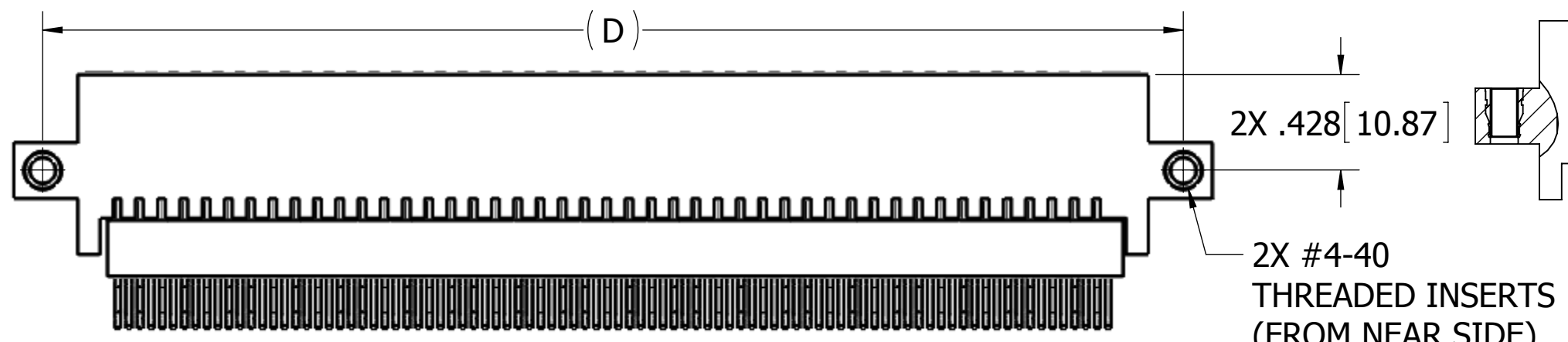

**--B--DLRA-S1251**

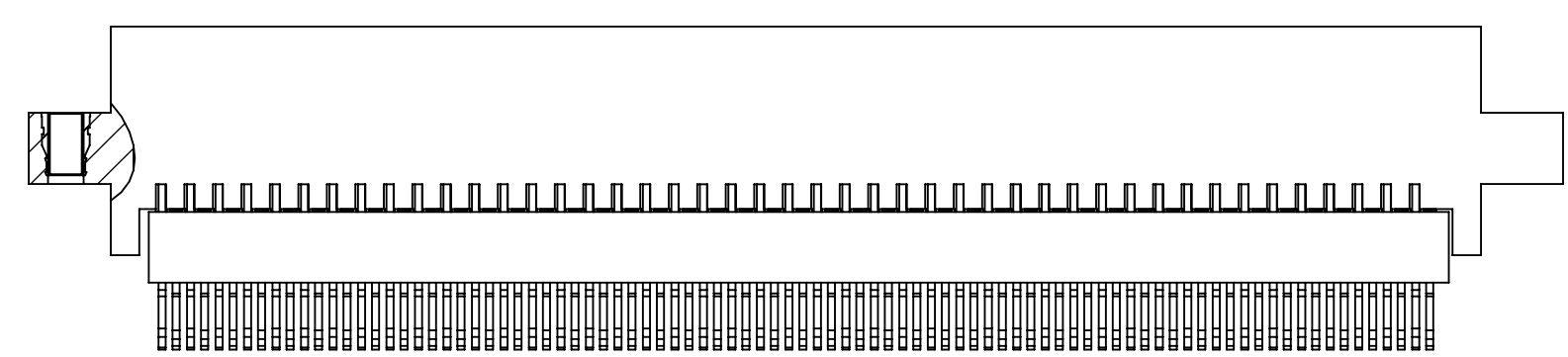
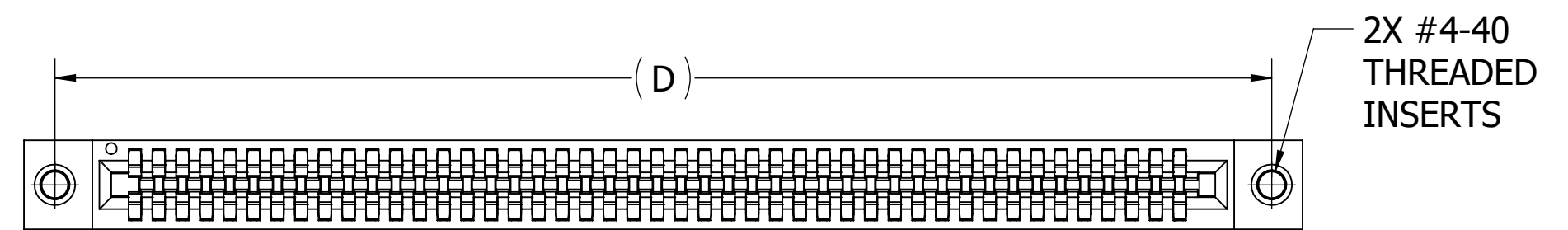

**--B--DLRI-S1251**

# CUSTOMER COPY



UNLESS OTHERWISE SPECIFIED:  
DIMENSIONS ARE IN INCHES [MM]

TOLERANCES:  
ANGULAR: ± 1°

DECIMALS  
.XX = ± .02 [.5]  
.XXX = ± .005 [.13]  
.XXXX = ± .0005 [.013]

DRAWN	DATE	NAME
	8/22/2008	ASK
<small>THE INFORMATION HEREIN CONTAINS PROPRIETARY INFORMATION OF SULLINS ELECTRONICS AND IS NOT TO BE REPRODUCED, USED OR DISCLOSED TO OTHERS FOR ANY PURPOSE EXCEPT AS SPECIFICALLY AUTHORIZED IN WRITING BY AN OFFICER OF SULLINS ELECTRONICS.</small>		

<b>SULLINS</b> CONNECTOR SOLUTIONS		
TITLE BI-LEVEL, .050 CC, .093 PCB, CE		
PART NUMBER --B--DLR--S1251		
SIZE C	CAGE CODE 54453	DWG. NO. C11140
SCALE: 3:2	SHEET 2 OF 4	
		REV B

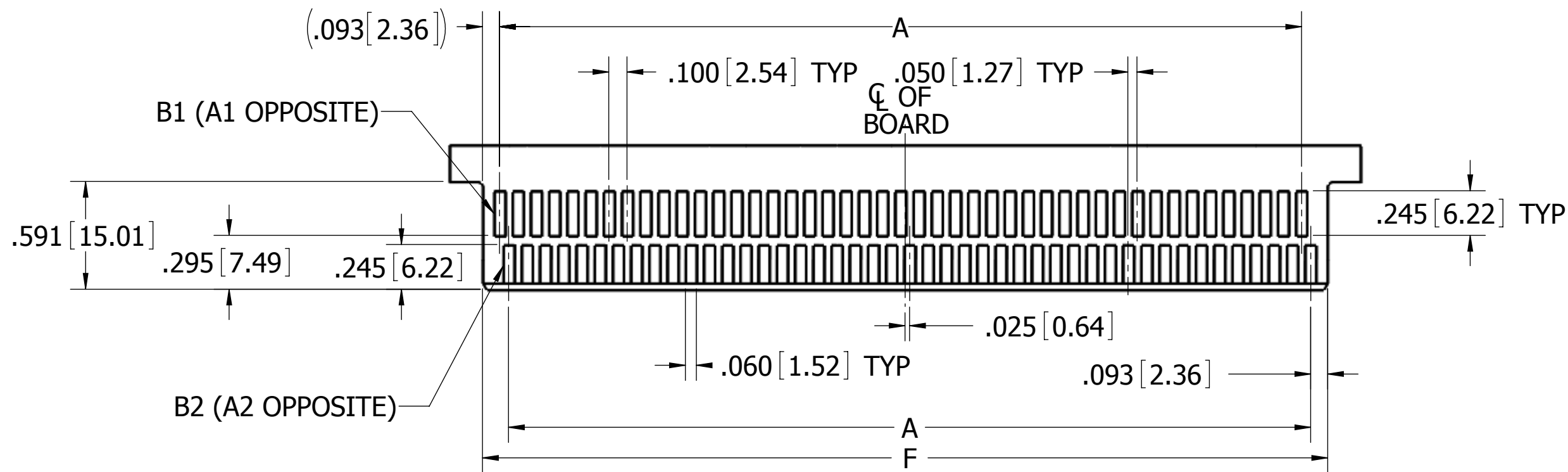

**DAUGHTER CARD LAYOUT NUMBER 1  
90 POSITION SHOWN  
REFER TO PAGE 4 TO DETERMINE LAYOUT TO USE**

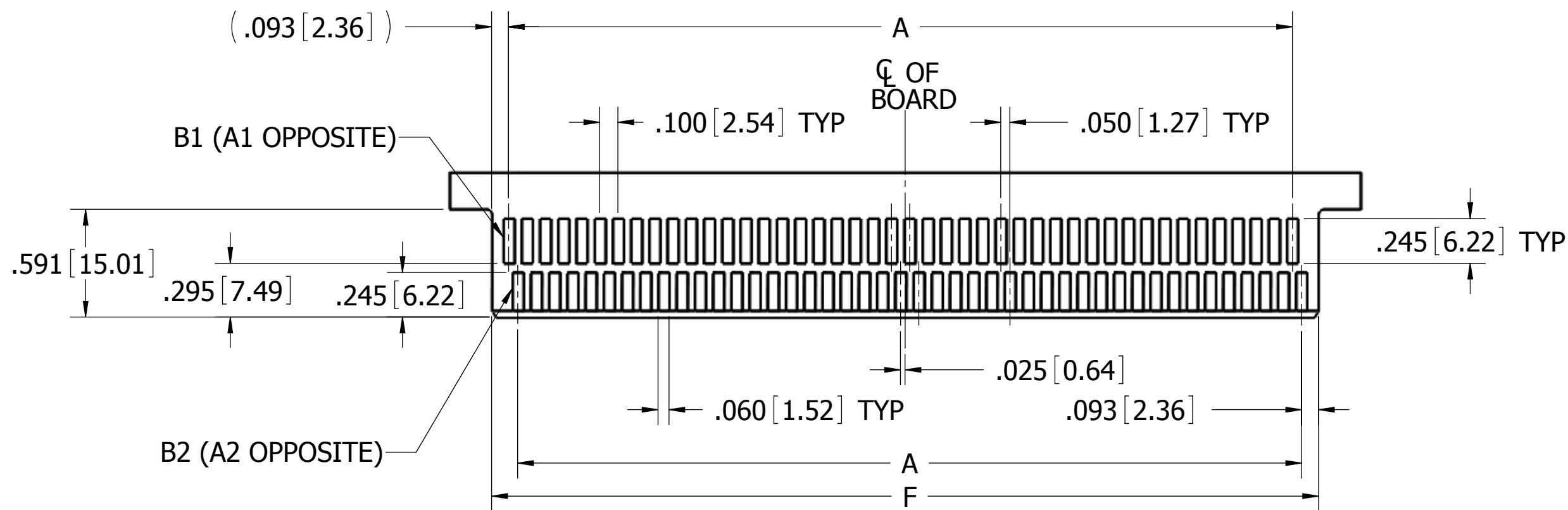

**DAUGHTER CARD LAYOUT NUMBER 2  
88 POSITION SHOWN  
REFER TO PAGE 4 TO DETERMINE LAYOUT TO USE**

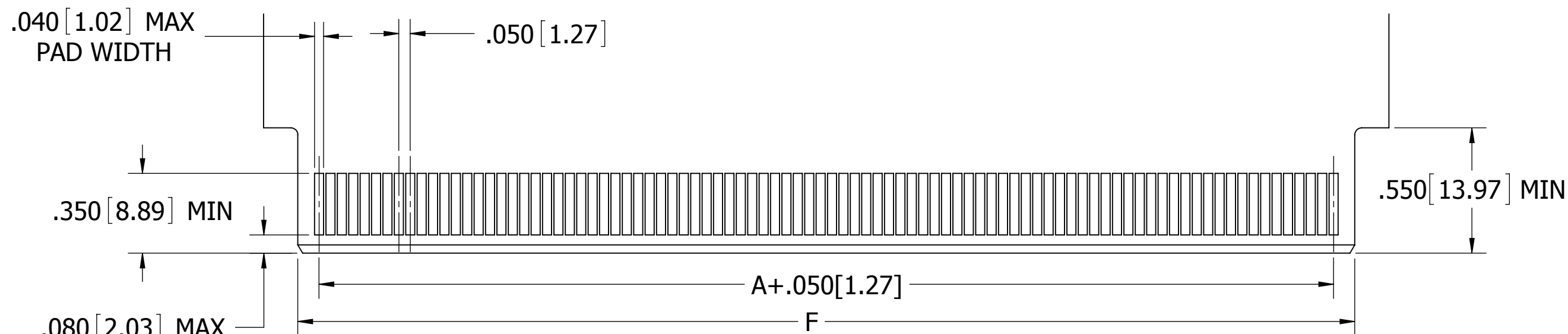

**PCB LAYOUT, SOLDER END  
90 POSITION SHOWN  
SCALE 2:1**

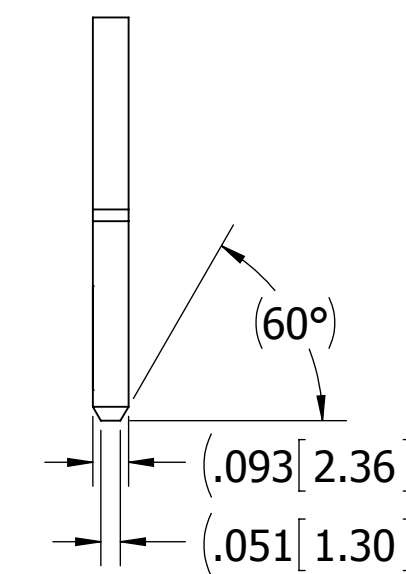
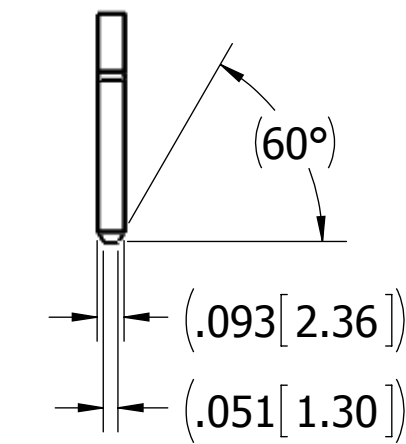
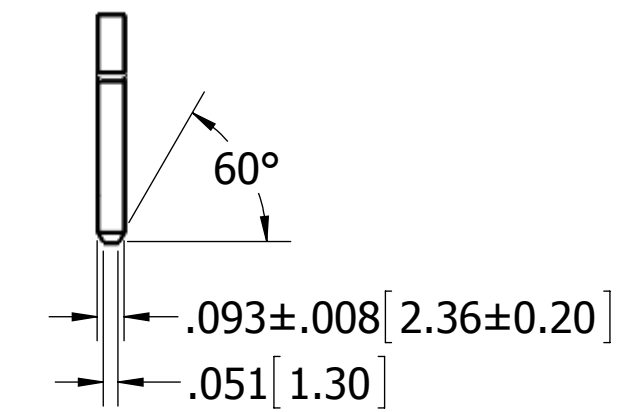

**CUSTOMER COPY**



UNLESS OTHERWISE SPECIFIED:  
DIMENSIONS ARE IN INCHES [MM]

TOLERANCES:

ANGULAR: ± 1°

DECIMALS

.XX= ± .02 [.5]

.XXX= ± .005 [.13]

.XXXX= ± .0005 [.013]

DRAWN	DATE	NAME
	8/22/2008	ASK

THE INFORMATION HEREIN CONTAINS PROPRIETARY INFORMATION OF SULLINS ELECTRONICS AND IS NOT TO BE REPRODUCED, USED OR DISCLOSED TO OTHERS FOR ANY PURPOSE EXCEPT AS SPECIFICALLY AUTHORIZED IN WRITING BY AN OFFICER OF SULLINS ELECTRONICS.

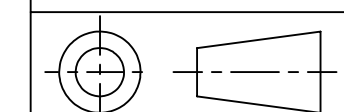

<b>SULLINS CONNECTOR SOLUTIONS</b>			
TITLE <b>BI-LEVEL, .050 CC, .093 PCB, CE</b>			
PART NUMBER <b>__B__DLR__S1251</b>			
SIZE	CAGE CODE	DWG. NO.	REV
<b>C</b>	<b>54453</b>	<b>C11140</b>	<b>B</b>
SCALE: 3:2		SHEET 3 OF 4	

PART NUMBER	POSITIONS	INCHES						POSITIONS	MILLIMETERS						DAUGHTER CARD LAYOUT
		A	B	C±.015	D±.010	E±.020	F		A	B	C±0.38	D±0.25	E±0.51	F	
B06DLR -S1251	6	0.200	0.450	0.610	0.925	1.185	0.436	6	5.08	11.43	15.49	23.50	30.10	11.07	1
B08DLR -S1251	8	0.300	0.550	0.710	1.025	1.285	0.536	8	7.62	13.97	18.03	26.04	32.64	13.61	2
B10DLR -S1251	10	0.400	0.650	0.810	1.125	1.385	0.636	10	10.16	16.51	20.57	28.58	35.18	16.15	1
B12DLR -S1251	12	0.500	0.750	0.910	1.225	1.485	0.736	12	12.70	19.05	23.11	31.12	37.72	18.69	2
B14DLR -S1251	14	0.600	0.850	1.010	1.325	1.585	0.836	14	15.24	21.59	25.65	33.66	40.26	21.23	1
B16DLR -S1251	16	0.700	0.950	1.110	1.425	1.685	0.936	16	17.78	24.13	28.19	36.20	42.80	23.77	2
B18DLR -S1251	18	0.800	1.050	1.210	1.525	1.785	1.036	18	20.32	26.67	30.73	38.74	45.34	26.31	1
B20DLR -S1251	20	0.900	1.150	1.310	1.625	1.885	1.136	20	22.86	29.21	33.27	41.28	47.88	28.85	2
B22DLR -S1251	22	1.000	1.250	1.410	1.725	1.985	1.236	22	25.40	31.75	35.81	43.82	50.42	31.39	1
B24DLR -S1251	24	1.100	1.350	1.510	1.825	2.085	1.336	24	27.94	34.29	38.35	46.36	52.96	33.93	2
B26DLR -S1251	26	1.200	1.450	1.610	1.925	2.185	1.436	26	30.48	36.83	40.89	48.90	55.50	36.47	1
B28DLR -S1251	28	1.300	1.550	1.710	2.025	2.285	1.536	28	33.02	39.37	43.43	51.44	58.04	39.01	2
B30DLR -S1251	30	1.400	1.650	1.810	2.125	2.385	1.636	30	35.56	41.91	45.97	53.98	60.58	41.55	1
B32DLR -S1251	32	1.500	1.750	1.910	2.225	2.485	1.736	32	38.10	44.45	48.51	56.52	63.12	44.09	2
B34DLR -S1251	34	1.600	1.850	2.010	2.325	2.585	1.836	34	40.64	46.99	51.05	59.06	65.66	46.63	1
B36DLR -S1251	36	1.700	1.950	2.110	2.425	2.685	1.936	36	43.18	49.53	53.59	61.60	68.20	49.17	2
B38DLR -S1251	38	1.800	2.050	2.210	2.525	2.785	2.036	38	45.72	52.07	56.13	64.14	70.74	51.71	1
B40DLR -S1251	40	1.900	2.150	2.310	2.625	2.885	2.136	40	48.26	54.61	58.67	66.68	73.28	54.25	2
B42DLR -S1251	42	2.000	2.250	2.410	2.725	2.985	2.236	42	50.80	57.15	61.21	69.22	75.82	56.79	1
B44DLR -S1251	44	2.100	2.350	2.510	2.825	3.085	2.336	44	53.34	59.69	63.75	71.76	78.36	59.33	2
B46DLR -S1251	46	2.200	2.450	2.610	2.925	3.185	2.436	46	55.88	62.23	66.29	74.30	80.90	61.87	1
B48DLR -S1251	48	2.300	2.550	2.710	3.025	3.285	2.536	48	58.42	64.77	68.83	76.84	83.44	64.41	2
B50DLR -S1251	50	2.400	2.650	2.810	3.125	3.385	2.636	50	60.96	67.31	71.37	79.38	85.98	66.95	1
B52DLR -S1251	52	2.500	2.750	2.910	3.225	3.485	2.736	52	63.50	69.85	73.91	81.92	88.52	69.49	2
B54DLR -S1251	54	2.600	2.850	3.010	3.325	3.585	2.836	54	66.04	72.39	76.45	84.46	91.06	72.03	1
B56DLR -S1251	56	2.700	2.950	3.110	3.425	3.685	2.936	56	68.58	74.93	78.99	87.00	93.60	74.57	2
B58DLR -S1251	58	2.800	3.050	3.210	3.525	3.785	3.036	58	71.12	77.47	81.53	89.54	96.14	77.11	1
B60DLR -S1251	60	2.900	3.150	3.310	3.625	3.885	3.136	60	73.66	80.01	84.07	92.08	98.68	79.65	2
B62DLR -S1251	62	3.000	3.250	3.410	3.725	3.985	3.236	62	76.20	82.55	86.61	94.62	101.22	82.19	1
B64DLR -S1251	64	3.100	3.350	3.510	3.825	4.085	3.336	64	78.74	85.09	89.15	97.16	103.76	84.73	2
B66DLR -S1251	66	3.200	3.450	3.610	3.925	4.185	3.436	66	81.28	87.63	91.69	99.70	106.30	87.27	1
B68DLR -S1251	68	3.300	3.550	3.710	4.025	4.285	3.536	68	83.82	90.17	94.23	102.24	108.84	89.81	2
B70DLR -S1251	70	3.400	3.650	3.810	4.125	4.385	3.636	70	86.36	92.71	96.77	104.78	111.38	92.35	1
B72DLR -S1251	72	3.500	3.750	3.910	4.225	4.485	3.736	72	88.90	95.25	99.31	107.32	113.92	94.89	2
B74DLR -S1251	74	3.600	3.850	4.010	4.325	4.585	3.836	74	91.44	97.79	101.85	109.86	116.46	97.43	1
B76DLR -S1251	76	3.700	3.950	4.110	4.425	4.685	3.936	76	93.98	100.33	104.39	112.40	119.00	99.97	2
B78DLR -S1251	78	3.800	4.050	4.210	4.525	4.785	4.036	78	96.52	102.87	106.93	114.94	121.54	102.51	1
B80DLR -S1251	80	3.900	4.150	4.310	4.625	4.885	4.136	80	99.06	105.41	109.47	117.48	124.08	105.05	2
B82DLR -S1251	82	4.000	4.250	4.410	4.725	4.985	4.236	82	101.60	107.95	112.01	120.02	126.62	107.59	1
B84DLR -S1251	84	4.100	4.350	4.510	4.825	5.085	4.336	84	104.14	110.49	114.55	122.56	129.16	110.13	2
B86DLR -S1251	86	4.200	4.450	4.610	4.925	5.185	4.436	86	106.68	113.03	117.09	125.10	131.70	112.67	1
B88DLR -S1251	88	4.300	4.550	4.710	5.025	5.285	4.536	88	109.22	115.57	119.63	127.64	134.24	115.21	2
B90DLR -S1251	90	4.400	4.650	4.810	5.125	5.385	4.636	90	111.76	118.11	122.17	130.18	136.78	117.75	1
B92DLR -S1251	92	4.500	4.750	4.910	5.225	5.485	4.736	92	114.30	120.65	124.71	132.72	139.32	120.29	2
B94DLR -S1251	94	4.600	4.850	5.010	5.325	5.585	4.836	94	116.84	123.19	127.25	135.26	141.86	122.83	1
B96DLR -S1251	96	4.700	4.950	5.110	5.425	5.685	4.936	96	119.38	125.73	129.79	137.80	144.40	125.37	2
B98DLR -S1251	98	4.800	5.050	5.210	5.525	5.785	5.036	98	121.92	128.27	132.33	140.34	146.94	127.91	1
B100DLR -S1251	100	4.900	5.150	5.310	5.625	5.885	5.136	100	124.46	130.81	134.87	142.88	149.48	130.45	2
B102DLR -S1251	102	5.000	5.250	5.410	5.725	5.985	5.236	102	127.00	133.35	137.41	145.42	152.02	132.99	1
B104DLR -S1251	104	5.100	5.350	5.510	5.825	6.085	5.336	104	129.54	135.89	139.95	147.96	154.56	135.53	2
B106DLR -S1251	106	5.200	5.450	5.610	5.925	6.185	5.436	106	132.08	138.43	142.49	150.50	157.10	138.07	1
B108DLR -S1251	108	5.300	5.550	5.710	6.025	6.285	5.536	108	134.62	140.97	145.03	153.04	159.64	140.61	2
B110DLR -S1251	110	5.400	5.650	5.810	6.125	6.385	5.636	110	137.16	143.51	147.57	155.58	162.18	143.15	1
B112DLR -S1251	112	5.500	5.750	5.910		5.736	112	139.70	146.05	150.11			145.69	2	
B114DLR -S1251	114	5.600	5.850	6.010	N MOUNTING ONLY	5.836	114	142.24	148.59	152.65	N MOUNTING ONLY		148.23	1	
B116DLR -S1251	116	5.700	5.950	6.110		5.936	116	144.78	151.13	155.19			150.77	2	
B118DLR -S1251	118	5.800	6.050	6.210		6.036	118	147.32	153.67	157.73			153.31	1	
B120DLR -S1251	120	5.900	6.150	6.310		6.136	120	149.86	156.21	160.27			155.85	2	

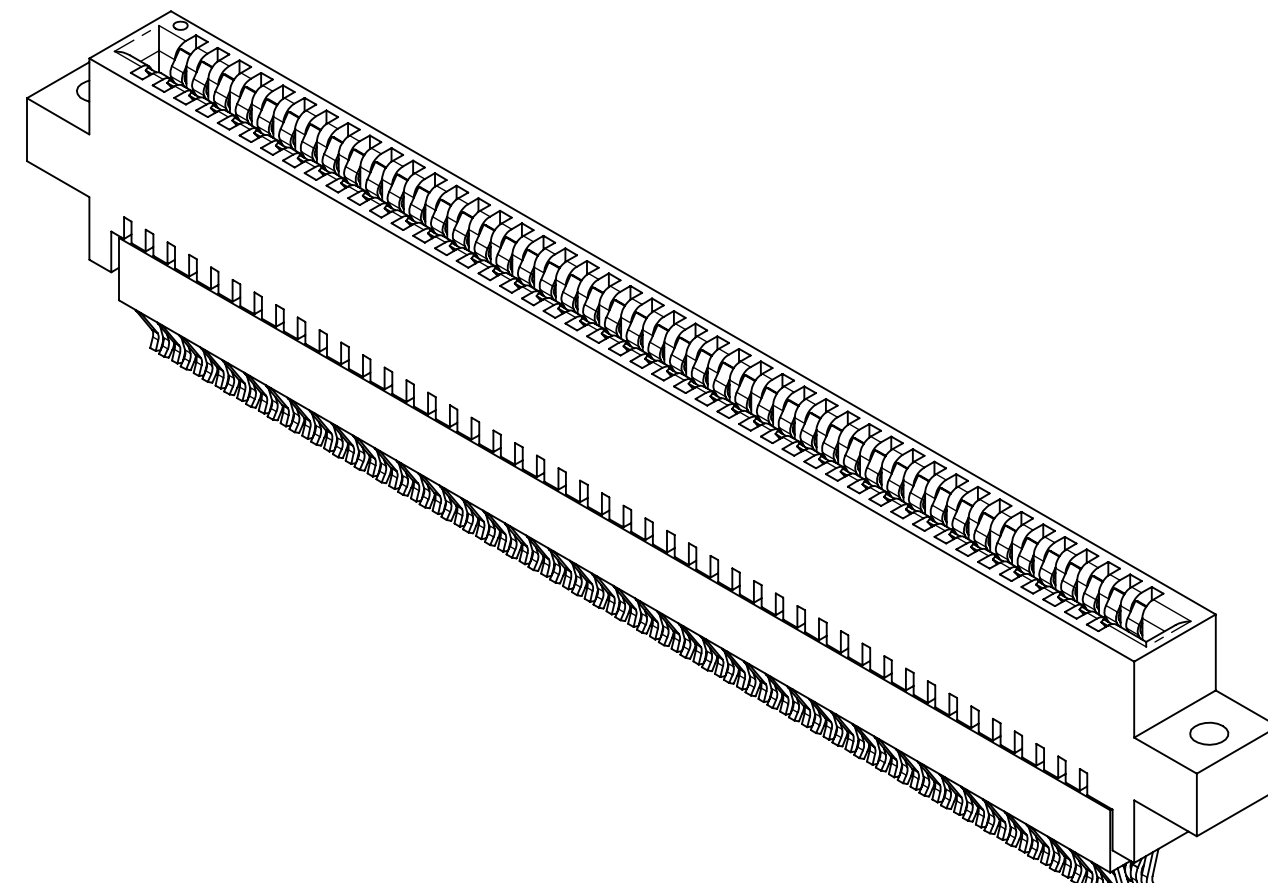

**PART NUMBER CODING**

**B** **DLR** **-S1251**

**MATERIALS (INSULATOR / CONTACT)**

**G = PA9T/PHOSPHOR BRONZE**

OPERATING TEMP: -65°C TO +125°C  
 PROCESSING TEMP: 260°C MAX FOR 20 SECS

**J = PA9T/BERYLLIUM COPPER**

OPERATING TEMP: -65°C TO +150°C  
 PROCESSING TEMP: 260°C MAX FOR 20 SECS

(CONSULT FACTORY FOR OTHER MATERIALS)

**MOUNTING STYLE**

- H = .125 DIA. MOUNTING HOLES
- S = .125 DIA. SIDE MOUNTING HOLES
- I = #4-40 THREADED INSERTS
- A = #4-40 THREADED INSERTS IN SIDE HOLES
- N = NO MOUNTING EARS

**NUMBER OF POSITIONS (CONTACT PER ROW)**

**PLATING**

ALL PLATINGS ARE LEAD FREE AND HAVE .000050" NICKEL UNDERPLATE

	CONTACT SURFACE	TERMINATION
C =	.000030" GOLD	.000100" PURE TIN, MATTE
B =	.000010" GOLD	.000100" PURE TIN, MATTE
Y =	.000030" GOLD	.000005" GOLD

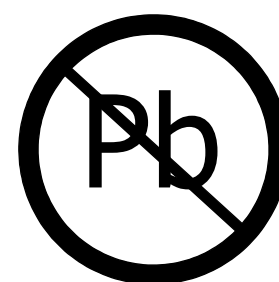

RoHS COMPLIANT

**CUSTOMER COPY**

UNLESS OTHERWISE SPECIFIED: DIMENSIONS ARE IN INCHES (MM)		DRAWN	DATE	NAME	
			8/22/2008	ASK	
TOLERANCES:					THE INFORMATION HEREIN CONTAINS PROPRIETARY INFORMATION OF SULLINS ELECTRONICS AND IS NOT TO BE REPRODUCED, USED OR DISCLOSED TO OTHERS FOR ANY PURPOSE EXCEPT AS SPECIFICALLY AUTHORIZED IN WRITING BY AN OFFICER OF SULLINS ELECTRONICS.
ANGULAR: ± 1°					
DECIMALS .XX = ± .02 [.5] .XXX = ± .005 [.13] .XXXX = ± .0005 [.013]					
TITLE: <b>BI-LEVEL, .050 CC, .093 PCB, CE</b>					
PART NUMBER: <b>B DLR -S1251</b>					
SIZE	CAGE CODE	DWG. NO.	REV		
<b>C</b>	<b>54453</b>	<b>C11140</b>	<b>B</b>		
SCALE: 2:1 SHEET 4 OF 4					