

General Description

The DA7212 is an ultra-low power audio codec targeting portable audio devices. The input paths support stereo FM line input and up to four analogue (or two analogue and two digital) microphones with two independent microphone biases. Comprehensive analogue mixing and bypass paths to the output drivers are available.

The headphone output is true-ground Class G with integrated charge pump. There is also a differential Class AB speaker driver that can serve as a mono lineout.

Digital audio transfer to/from the external processor is via a bi-directional digital audio interface that supports all common sample rates and formats. The device may be operated in slave or master modes using the internal PLL which may be bypassed if not required.

To fully optimise each customer application, a range of built in filtering, equalisation and audio enhancements are available. These are accessible by the processor over the I²C serial interface.

Key Features

- 100 dB SNR stereo audio playback into 16 Ω headphones
- 3.1 mW power consumption for stereo DAC to headphone playback
- 1.2 W mono speaker driver
- 650 μ W mono voice record
- Stereo digital microphone support
- Supports up to four analogue microphones
- Two low-noise microphone-bias outputs
- Low-power PLL provides system clocking and audio sample rate flexibility
- Built-in 5-band equaliser, ALC and noise-gate functions
- Built-in beep generator
- Integrated system controller to eliminate pops and clicks
- Minimised external component count
- 34-ball WL-CSP (4.54 mm x 1.66 mm) package
- Staggered 0.5 mm pitch for easy PCB routing allowing low cost manufacture

Applications

- Personal Media Players
- Audio headphone/headsets
- Wearables
- Embedded applications
- Arduino compatible development systems



Figure 1: The DA7212 chip

Contents

General description	1
Key features	1
Applications	1
Contents	2
Figures	4
Tables	5
1 Terms and definitions	7
2 Block diagram	8
3 Pinout	9
4 Absolute maximum ratings	11
5 Recommended operating conditions	11
6 Electrical characteristics	12
7 Parametric specifications	13
8 Digital signal processing	16
9 Audio outputs	18
10 Clock generation	22
11 Phase locked loop (PLL)	22
12 Digital interfaces	23
12.1 Codec start-up time	26
13 Functional description	28
13.1 General description	28
13.2 Input signal chain	29
13.3 Microphone inputs	30
13.4 Digital microphones	30
13.5 Auxiliary inputs	31
13.6 Input mixers	32
13.7 Stereo audio ADC	32
13.8 Automatic level control (ALC)	33
13.9 Beep generator and controller	35
13.10 Output signal chain	36
13.11 Stereo audio DAC	36
13.12 Output mixer	37
13.13 Headphone amplifier	37
13.14 Speaker amplifier	38
13.15 Charge pump control	38
13.16 Charge pump clock control	40
13.17 Boosting the charge pump using demand feedback control	41
13.17.1 Tracking the demands on the charge pump output	41
13.17.1.1 CP_MCHANGE = 00 (manual mode)	41
13.17.1.2 CP_MCHANGE = 01 (tracking the PGA gain setting)	41

Ultra-Low Power Stereo Codec

13.17.1.3	CP_MCHANGE = 10 (tracking the DAC signal setting)	41
13.17.1.4	CP_MCHANGE = 11 (tracking the output signal magnitude)	41
13.17.2	Specifying clock frequencies when tracking the charge pump output demand	41
13.17.3	Controlling the boost of the charge pump clock-frequency	41
13.17.3.1	CP_ANALOGUE_LVL = 01	42
13.17.3.2	CP_ANALOGUE_LVL = 10	42
13.18	Other charge pump controls	43
13.19	Digital signal processing engine	44
13.20	Variable high-pass audio filter (DC Cut)	44
13.21	Variable high pass filter (wind noise filtering)	45
13.22	DAC 5-band equaliser	46
13.23	Soft mute	49
13.24	Playback noise-gate	49
13.25	Clock modes	49
13.26	PLL bypass mode	51
13.26.1	Normal PLL mode (DAI master)	52
13.26.2	Example calculation of the feedback divider setting:	53
13.27	SRM PLL mode (DAI slave)	54
13.28	32 kHz PLL mode (DAI master)	54
13.29	Operating with a 2 MHz to 5 MHz MCLK	54
13.30	Mixed sample rates	54
13.31	I2C control interface	55
13.32	Details of the I2C control interface protocol	56
13.33	Digital audio interface (DAI)	58
13.34	I2S mode	59
13.35	Left justified mode	59
13.36	Right justified mode	60
13.37	DSP mode	61
13.38	Time division multiplexing (TDM) mode	62
13.38.1	Configuration of the digital audio interface	63
13.39	Pop-free and click-free start-up using the system controllers	63
13.39.1	Level 1 system controller (SCL1)	63
13.39.2	Level 2 system controller (SCL2)	64
13.40	Power supply – standby mode	64
13.40.1	Entering standby mode	64
13.40.2	Exiting standby mode	64
14	Register definitions	65
14.1	Register map	65
14.2	Status registers	71
14.3	System initialisation registers	76
14.4	Input gain/select filter registers	82
14.5	Output gain-filter registers	87
14.6	System controller registers	95
14.7	Control registers	97
14.8	Mixed sample mode registers	106

Ultra-Low Power Stereo Codec

14.9	Configuration registers	107
15	Package information	123
15.1	Package outlines	123
15.2	Soldering information	124
16	Ordering information	124
Appendix A Applications information		125
A.1	Codec initialisation	125
A.2	Automatic ALC calibration.....	125
A.3	Troubleshooting	126
Appendix B Components.....		127
B.1	Audio inputs	127
B.2	Microphone bias.....	128
B.3	Digital microphone	128
B.4	Audio outputs	128
B.5	Headphone charge pump	129
B.6	Digital interfaces.....	130
B.7	References.....	131
B.8	Supplies	131
B.9	Ground	132
B.10	Capacitor selection.....	132
Appendix C PCB layout guidelines		133
C.1	Layout and schematic support.....	133
C.2	General recommendations.....	133
Revision history.....		134

Figures

Figure 1:	The DA7212 chip.....	1
Figure 2:	Block diagram showing component values for a typical application	8
Figure 3:	DA7212 ball layout	9
Figure 4:	I2C bus timing	24
Figure 5:	Digital audio interface timing diagram	25
Figure 6:	Audio input routing and gain ranges	29
Figure 7:	Typical microphone application for MIC1 (MIC2 is similar).....	30
Figure 8:	Digital microphone timing example	31
Figure 9:	Principle of operation of the ALC	33
Figure 10:	Attack, delay and hold parameters.....	34
Figure 11:	Analogue output signal paths and gain ranges.....	36
Figure 12:	Input (clk) and output clocks (cp_clk and cp_clk2) at CP_FCONTROL = 010	40
Figure 13:	ADC and DAC DC blocking (Cut-off frequency setting '00' to '11', 16 kHz)	45
Figure 14:	Wind noise high-pass filter (cut-off frequency setting '000' to '111', 16 kHz)	46
Figure 15:	Equaliser filter band 1 frequency response at FS = 48 kHz.....	47
Figure 16:	Equaliser filter band 2 frequency response at FS = 48 kHz.....	47
Figure 17:	Equaliser filter band 3 frequency response at FS = 48 kHz.....	48
Figure 18:	Equaliser filter band 4 frequency response at FS = 48 kHz.....	48
Figure 19:	Equaliser filter band 5 frequency response at FS = 48 kHz.....	49
Figure 20:	Schematic of the I2C control interface bus	55

Figure 21: Timing of I2C START and STOP conditions	56
Figure 22: I2C byte write (SDA signal)	56
Figure 23: Examples of the I2C byte read (SDA line)	57
Figure 24: Examples of I2C page read (SDA line)	57
Figure 25: I2C page write (SDA line).....	57
Figure 26: I2C repeated write (SDA line)	58
Figure 27: Master mode (DAI_CLK_EN = 1).....	58
Figure 28: Slave mode (DAI_CLK_EN = 0).....	59
Figure 29: I2S mode	59
Figure 30: Left justified mode	60
Figure 31: Right justified mode	60
Figure 32: DSP mode	61
Figure 33: TDM example (slave mode)	62
Figure 34: TDM mode (left justified mode)	62
Figure 35: DA7212 package outline drawing	123
Figure 36: MICBIAS decoupling	128
Figure 37: Recommended headphone layout	128
Figure 38: Charge pump decoupling	129
Figure 39: Charge pump flying capacitor	130
Figure 40: I2C pull ups	130
Figure 41: Reference capacitors	131
Figure 42: Power supply decoupling	131
Figure 43: Example layout.....	133

Tables

Table 1: Pin descriptions	9
Table 2: Pin type definition	10
Table 3: Absolute maximum ratings	11
Table 4: Recommended operating conditions	11
Table 5: Power consumption	12
Table 6: Reference voltage generation	12
Table 7: Analogue to digital converter (ADC).....	13
Table 8: Microphone bias	14
Table 9: Input mixing units.....	15
Table 10: ADC/DAC digital high-pass filter cut-off frequencies in music mode	16
Table 11: ADC/DAC Digital high-pass filter cut-off frequencies in voice mode.....	16
Table 12: DAC 5-band equaliser frequencies	17
Table 13: Beep generator.....	17
Table 14: Digital to analogue converter (DAC)	18
Table 15: Class AB lineout amplifier / speaker.....	19
Table 16: True ground charge pump.....	20
Table 17: True ground headphone amplifier	21
Table 18: MCLK input.....	22
Table 19: PLL mode	22
Table 20: Bypass mode.....	22
Table 21: I/O characteristics.....	23
Table 22: I2C control bus (VDD_IO = 1.8 V).....	24
Table 23: Digital audio interface timing (I2S/DSP in master/slave mode)	26
Table 24: Codec start-up times	26
Table 25: DTMF keypad frequencies	35
Table 26: Charge pump output voltage control	38
Table 27: CP_THRESH_VDD2 settings in DAC_VOL mode (CP_MCHANGE = 10).....	39
Table 28: CP_THRESH_VDD2 settings in signal size mode (CP_MCHANGE = 11).....	40
Table 29: Charge pump current load control.....	43
Table 30: ADC/DAC digital high-pass filter specifications in audio mode	44

Ultra-Low Power Stereo Codec

Table 31: Wind noise high-pass filter specifications	45
Table 32: DAC 5-band equaliser turnover/centre frequencies	46
Table 33: PLL clock modes	50
Table 34: Sample rate control register and corresponding system clock frequency.....	51
Table 35: PLL input divider.....	52
Table 36: Example PLL configurations.....	53
Table 37: Ordering information.....	124
Table 38: Offset calibration, MIC1_P and MIC2_P single ended, slave mode	126
Table 39: Audio inputs.....	127
Table 40: Microphone bias	128
Table 41: Digital microphones.....	128
Table 42: Headphone outputs	128
Table 43: Speaker outputs	129
Table 44: Headphone charge pump.....	129
Table 45: Digital interfaces - I2C	130
Table 46: Digital interfaces - I2S	130
Table 47: References	131
Table 48: Power supplies	131
Table 49: Ground.....	132
Table 50: Recommended capacitor types.....	132

1 Terms and Definitions

ADC	Analogue Digital Converter
ALC	Automatic Level Control
DAC	Digital Audio Converter
DAI	Digital Audio Interface
DTMF	Dual Tone Multi Frequency
I2C	Inter-Integrated Circuit interface
I2S	Inter-IC Sound
PLL	Phase Locked Loop
PSRR	Power Supply Rejection Ratio
SNR	Signal to Noise Ratio
TDM	Time Division multiplexing
THD+N	Total Harmonic Distortion plus Noise
WL-CSP	Wafer Level-Chip Scale Packaging

2 Block Diagram

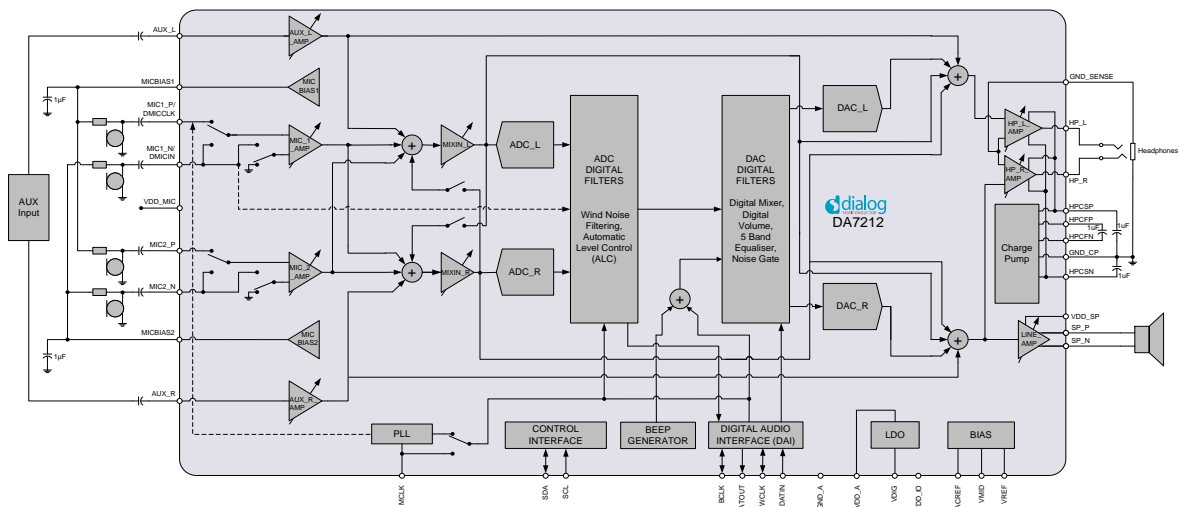

Figure 2: Block diagram showing component values for a typical application

ADC Digital Filter: Analogue filter block incorporating wind noise filtering and Automatic Level Control (ALC).

DAC Digital Filter: Digital filter block incorporating digital mixing, digital volume control, a 5 band equaliser and a noise gate.

Beep Generator: The Beep Generator block has two sine wave generators, each of which can be independently controlled. Output frequency is controllable in 10 Hz step sizes, and output gain is controllable in 3 dB steps from 0 dB to 45 dB. The Beep Generator block can also output standard DTMF keypad frequencies (see [Table 25](#)).

3 Pinout

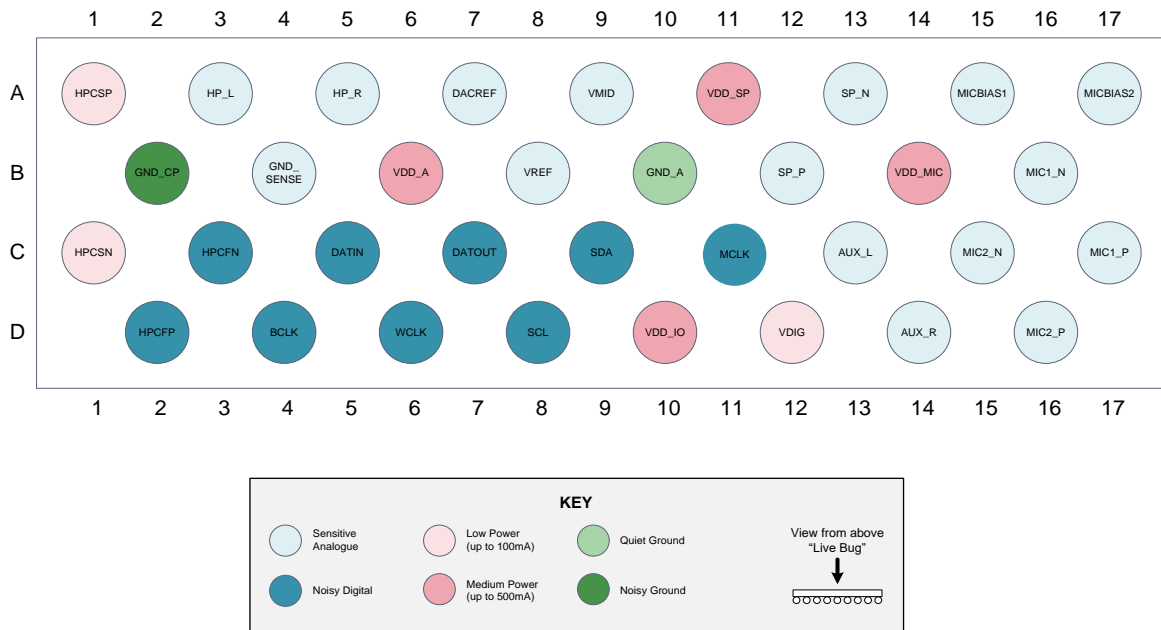

Figure 3: DA7212 ball layout

Table 1: Pin descriptions

Pin Name	Bump/Pin	Function	Alternate Function	Class
Audio Inputs				
MIC1_P	C17	Differential mic. input 1 (pos) / Single-ended mic. input 1 (left)	Digital mic. clock (DMICCLK)	AI/DO
MIC1_N	B16	Differential mic. input 1 (neg) / Single-ended mic. input 2 (left)	Digital Mic. data (DMICIN)	AI/DI
MIC2_P	D16	Differential mic. input 2 (pos) / Single-ended mic. input 1 (right)		AI
MIC2_N	C15	Differential mic. input 2 (neg) / Single-ended mic. input 2 (right)		AI
AUX_L	C13	Single-ended auxiliary input left		AI
AUX_R	D14	Single-ended auxiliary input right		AI
MICBIAS1	A15	Microphone bias output 1		AO
MICBIAS2	A17	Microphone bias output 2		AO
Audio Ouputs				
HP_L	A3	True-ground headphone output left		AO
HP_R	A5	True-ground headphone output right		AO
SP_P	B12	Differential speaker output (pos)		AO
SP_N	A13	Differential speaker output (neg)		AO
Audio Charge Pump				
HPCSP	A1	Charge pump reservoir capacitor (pos)		AIO
HPCSN	C1	Charge pump reservoir capacitor (neg)		AIO

Ultra-Low Power Stereo Codec

Pin Name	Bump/Pin	Function	Alternate Function	Class
HPCFP	D2	Charge pump flyback capacitor (pos)		AIO
HPCFN	C3	Charge pump flyback capacitor (neg)		AIO
Digital Interfaces				
SDA	C9	I2C bi-directional data		DIO
SCL	D8	I2C clock input		DI
DATIN	C5	DAI data input		DIO
DATOUT	C7	DAI data output		DIO
BCLK	D4	DAI bit clock		DIO
WCLK	D6	DAI word clock (L/R select)		DIO
MCLK	C11	Master clock		DI
References				
DACREF	A7	Audio DAC reference capacitor		AIO
VMID	A9	Audio mid-rail reference capacitor		AIO
GND_SENSE	B4	Ground reference for headphone output		AI
VREF	B8	Bandgap reference capacitor		AIO
Supplies				
VDD_A	B6	Supply for analogue circuits		PS
VDD_IO	D10	Supply for digital interfaces		PS
VDD_SP	A11	Supply for speaker driver		PS
VDD_MIC	B14	Supply for microphone bias circuits		PS
VDIG	D12	Supply for digital circuits (LDO Output)		PS
Grounds				
GND_A	B10	Analogue ground		PG
GND_CP	B2	Digital ground/charge pump		PG

Table 2: Pin type definition

Pin type	Description	Pin type	Description
DI	Digital Input	AI	Analog Input
DO	Digital Output	AO	Analog Output
DIO	Digital Input/Output	AIO	Analog Input/Output
PS	Power Supply	PG	Power Ground

4 Absolute Maximum Ratings

Table 3: Absolute maximum ratings

Parameter	Description	Conditions (Note 1)	Min	Max	Unit
	Storage temperature		-65	+165	°C
T _a	Operating temperature		-40	+85	°C
VDD_SP	Supply voltages		-0.3	6.0	V
VDD_A			-0.3	2.75	V
VDD_IO VDD_MIC			-0.3	5.5	V
SDA SCL BCLK WCLK DATIN DATOUT	Digital interface signals		-0.3	VDD_IO + 0.3	V
	Package thermal resistance		60		°C/W
	ESD susceptibility	Human body model		2	kV

Note 1 Stresses beyond those listed under ‘Absolute maximum ratings’ may cause permanent damage to the device. These are stress ratings only, so functional operation of the device at these or any other conditions beyond those indicated in the operational sections of the specification are not implied. Exposure to absolute maximum rating conditions for extended periods may affect device reliability.

5 Recommended Operating Conditions

Table 4: Recommended operating conditions

Parameter	Description	Conditions	Min	Typ	Max	Unit
T _a	Operating temperature		-40		+85	°C
VDD_A	Supply voltages		1.6		2.65	V
VDD_IO			1.5		3.6	V
VDD_MIC			1.8		3.6	V
VDD_SP			0.95		5.25	V

Note 2 If the speaker output is not used then VDD_SP can be left unconnected

6 Electrical Characteristics

Table 5: Power consumption

Description	Conditions (Note 3)	Typ	Unit
Powerdown mode		5	μA
Digital playback to Lineout	DAC_L/R to LINE, 10 kΩ load	2.2	mW
Digital playback to Headphone, no load	DAC_L/R to HP_L/R, quiescent	3.1	mW
Digital playback to Headphone, with load	DAC_L/R to HP_L/R, 16 Ω load, 0.1 mW at 0 dBFS	6.9	mW
Analogue bypass to Lineout	AUX_L/R to LINE, 10 kΩ load	2.0	mW
Analogue bypass to Headphone, no load	AUX_L/R to HP_L/R, quiescent	2.6	mW
Analogue bypass to Headphone, with load	AUX_L/R to HP_L/R, 16 Ω load, 0.1 mW at 0 dBFS	6.7	mW
Microphone stereo record	MIC_1/2 to ADC_L/R	2.1	mW
Microphone stereo record and digital playback to Headphone, no load	MIC_1/2 to ADC_L/R and DAC_L/R to HP_L/R, quiescent	4.8	mW
Microphone stereo record and digital playback to Headphone, with load	MIC_1/2 to ADC_L/R and DAC_L/R to HP_L/R, 16 Ω load, 0.1 mW at 0 dBFS	8.9	mW
Ultra-low power microphone mono record	MIC_1 to ADC_R, 8 kHz, quiescent, optimised clocking and bias	0.65	mW

Note 3 VDD_A=VDD_SP=VDD_IO=1.8 V, Ta=25°C, Fs=48 kHz, Charge pump signal-size mode, 0x95 = 0x06.

Table 6: Reference voltage generation

Parameter	Description	Conditions	Min	Typ	Max	Unit
VMID	Audio mid-rail voltage			0.45 × VDD_A		V
C _{VMID}	VMID decoupling capacitor			1.0		μF
DACREF	Audio DAC/ADC reference voltage			0.9 × VDD_A		V
C _{DACREF}	DACREF decoupling capacitor			1.0		μF
VBG	Bandgap voltage			1.2		V
C _{VBG}	Bandgap decoupling capacitor			1.0		μF

7 Parametric Specifications

Table 7: Analogue to digital converter (ADC)

Parameter	Description	Conditions	Min	Typ	Max	Unit
V_{MAX}	Full-scale input signal	Digital output level = 0 dBFS		$1.6 \times V_{DD_A}$		V_{PP}
SNR (Note 4)	Signal to noise ratio	A-weighted no input selected		90		dB
THD+N (Note 5)	Total harmonic distortion plus noise	-1 dBFS 44.1 kHz slave mode		-85		dB
		-1 dBFS 32 kHz PLL mode		-80		dB
	In-band spurious	Analog input level = 0 dBFS		-85		dB
	Channel separation			90		dB
B_{PASS}	Pass band				$0.45 \times F_s$	Hz
B_{STOP}	Stop band	$F_s \leq 48$ kHz $F_s = 88.2/96$ kHz	$0.56 \times F_s$		$7 \times F_s$ $3.5 \times F_s$	Hz
	Pass band ripple	Voice mode Music mode			± 0.3 ± 0.1	dB
	Stop band attenuation	Voice mode Music mode	70 55			dB
	Group delay	Voice mode Music mode $F_s = 88.2/96$ kHz		$4.3/F_s$ $18/F_s$ $9/F_s$		s
	Group delay mismatch	Between left and right channels		2		μs
PSRR (Note 6) with respect to V_{DD_A}	Power supply rejection ratio	20 Hz – 2 kHz 2 kHz – 20 kHz	70 50			dB

Note 4 SNR (Signal-to-Noise Ratio) is a ratio of the full-scale output signal level to the noise level with no signal applied.

Note 5 THD+N (Total Harmonic Distortion plus Noise) is a ratio of the level of the harmonics and noise to the output signal.

Note 6 PSRR (Power Supply Rejection Ratio) is a measure of the attenuation of a signal on the supply to the signal at the output.

Table 8: Microphone bias

MICBIAS1 and MICBIAS2						
Parameter	Description	Conditions	Min	Typ	Max	Unit
V _{MICBIAS}	Bias voltage	No load, VDD_MIC > V _{MICBIAS} + 200 mV	1.52	1.57	1.62	V
			2.18	2.25	2.32	
			2.41	2.48	2.56	
			2.91	3.00	3.10	
I _{BIAS}	Maximum current	Voltage drop < 50 mV		2		mA
PSRR with respect to VDD_MIC	Power supply rejection ratio	20 Hz – 200 Hz >2 kHz	70 50			dB
V _{NOISE}	Output noise voltage	V _{MICBIAS} ≤ 2.2 V		5		μV _{RMS}
	Capacitive load	I _{BIAS} < 100 μA 100 μA < I _{BIAS} < 2 mA		100 200		pF

Table 9: Input mixing units

(MIC1_P/MIC1_N/MIC2_P/MIC2_N/AUX_L/AUX_R) to ADC_L/ADC_R						
Parameter	Description	Conditions	Min	Typ	Max	Unit
V _{MAX}	Full-scale input signal	Single-ended Differential MIC_1/2_AMP = AUX_L/R_AMP = MIXIN_L/R = 0 dB		0.8 × VDD_A 1.6 × VDD_A		V _{PP}
R _{IN}	Input resistance	MIC, single-ended AUX	12 6	15	18 40	kΩ
C _{IN}	Input capacitance			1		pF
	Amplitude ripple	20 Hz to 20 kHz	-0.5		+0.5	dB
	Programmable gain	MIC_1_AMP and MIC_2_AMP AUX_L_AMP and AUX_R_AMP MIXIN_L and MIXIN_R	-6 -54 -4.5		36 15 18	dB
	Programmable gain step size	MIC_1_AMP and MIC_2_AMP AUX_L_AMP and AUX_R_AMP MIXIN_L and MIXIN_R		6 1.5 1.5		dB
	Absolute gain accuracy	0 dB @ 1 kHz	-1.0		+1.0	dB
	Left/Right gain mismatch	20 Hz to 20 kHz	-0.1		+0.1	dB
	Gain step error	20 Hz to 20 kHz	-0.1		+0.1	dB
	Input noise level	Inputs connected to GND, A-weighted, input- referred, measured @ ADC output MIC_1/2_AMP = 24 dB AUX_L/R_AMP = 15 dB		5 6.5		μV _{RMS}
PSRR with respect to VDD_A	Power supply rejection ratio	Single-ended input 20 Hz to 2 kHz	70			dB
		20 kHz	50			
		Differential input 20 Hz – 2 kHz	90			dB
		2 kHz – 20 kHz	70			

8 Digital Signal Processing

Table 10: ADC/DAC digital high-pass filter cut-off frequencies in music mode

Sampling frequency (kHz)	Music mode – cut-off frequency (-3 dB) in Hz at ADC_AUDIO_HPF_CORNER / DAC_AUDIO_HPF_CORNER register settings			
	00	01	10	11
8	0.3	0.7	1.3	2.7
11.025	0.4	0.9	1.8	3.7
12	0.5	1	2	4
16	0.7	1.3	2.7	5.3
24	1	2	4	8
32	1.3	2.7	5.3	10.7
44.1	1.8	3.7	7.3	14.7
48	2	4	8	16
88.2	3.6	7.4	14.6	29.4
96	4	8	16	32

Table 11: ADC/DAC Digital high-pass filter cut-off frequencies in voice mode

Sampling frequency (kHz)	Voice mode – cut-off frequency (-3 dB) in Hz at ADC_AUDIO_HPF_CORNER / DAC_AUDIO_HPF_CORNER register settings							
	000	001	010	011	100	101	110	111
8	2.66	25	50	100	150	200	300	400
11.025	3.5	35	69	138	207	275	415	553
12	4	37.5	75	150	225	300	450	600
16	5	50	100	200	300	400	600	800

Table 12: DAC 5-band equaliser frequencies

Sampling frequency (kHz)	Centre/cut-off frequency of 5-band equaliser (Hz)				
	Band 1 cut-off (Note 7)	Band 2 centre	Band 3 centre	Band 4 centre	Band 5 cut-off (Note 7)
8	21	85	563	1151	2909
11.025	29	117	776	2137	4009
12	31	128	845	2326	4364
16	41	90	441	2128	5840
22.05	56	124	607	2933	8048
24	61	135	664	3192	8759
32	58	95	418	1731	6374
44.1	80	132	577	2385	8784
48	87	143	628	2596	9560
88.2	N/A	N/A	N/A	N/A	N/A
96	N/A	N/A	N/A	N/A	N/A

Note 7 For equaliser bands 1 and 5 the cut-off frequency depends on the gain setting. The figures quoted in this table refer to the -1 dB point with the band gain set to -3 dB

Table 13: Beep generator

Parameter	Description	Conditions	Min	Typ	Max	Unit
	Single-tone frequency		10		12000	Hz
	Single-tone frequency step			10		Hz
	Dual-tone modulation frequency A			697 770 852 941		Hz
	Dual-tone modulation frequency B			1209 1336 1477 1633		Hz
	Output signal level		45		0	dBFS
	Output signal step size			3		dB
T _{ON} , T _{OFF}	On/off pulse duration		10		2000	ms
	On/off pulse step size	T _{ON/OFF} =10 – 200 ms T _{ON/OFF} =200 – 2000 ms		10 50		ms
	On/off pulse repeat	Continuous mode		1,2,4,8,16,32 ∞		cycles

9 Audio Outputs

Table 14: Digital to analogue converter (DAC)

Parameter	Description	Conditions	Min	Typ	Max	Unit
V_{MAX}	Full-scale output signal	Digital input level = 0 dBFS		$1.6 \times V_{DD_A}$		V_{PP}
SNR	Signal to noise ratio	A-weighted		100		dB
THD+N	Total harmonic distortion plus noise	-1 dBFS 44.1 kHz slave mode		-90		dB
		-1 dBFS 32 kHz PLL mode		-80		dB
	Channel separation			90		dB
B_{PASS}	Pass band				$0.45 \times F_s$	kHz
B_{STOP}	Stop band	$F_s \leq 48$ kHz $F_s = 88.2/96$ kHz	$0.56 \times F_s$		$7 \times F_s$ $3.5 \times F_s$	kHz
	Pass band ripple	Voice mode Music mode			± 0.15 ± 0.1	dB
	Stop band attenuation	Voice mode Music mode	70 55			dB
	Group delay	Voice mode Music mode $F_s = 88.2/96$ kHz		$4.8/F_s$ $18.5/F_s$ $9/F_s$		s
	Group delay variation	20 Hz to 20 kHz		1		μs
	Group delay mismatch	Between left and right channels		2		μs
PSRR with respect to V_{DD_A}	Power supply rejection ratio	20 Hz – 2 kHz 2 kHz – 20 kHz	70 50			dB

Table 15: Class AB lineout amplifier / speaker

From DAC_L/DAC_R to (SP_P, SP_N)						
Parameter	Description	Conditions	Min	Typ	Max	Unit
V _{MAX}	Full-scale output signal	No load		1.8×VDD _{SP}		V _{PP}
P _{MAX}	Maximum output power	VDD _{SP} = 1.2 V THD < 10 % R _{LOAD} = 8 Ω, 1 kHz		65		mW _{RMS}
		VDD _{SP} = 1.5 V THD < 10 % R _{LOAD} = 8 Ω, 1 kHz		115		mW _{RMS}
		VDD _{SP} = 3.7 V THD < 10 % R _{LOAD} = 8 Ω, 1 kHz		745		mW _{RMS}
		VDD _{SP} = 5.0 V THD < 10 % R _{LOAD} = 8 Ω, 1 kHz		1200		mW _{RMS}
R _{LOAD}	Load impedance		6.4	8	1 200	Ω μH pF
		Frequency response	±0.5 dB	20	20k	Hz
	Amplitude ripple	20 Hz to 20 kHz	-0.5		0.5	dB
	Programmable gain		-48		+15	dB
	Mute attenuation			100		dB
	Programmable gain step size			1		dB
	Absolute gain accuracy	0 dB @ 1 kHz	-0.8		+0.8	dB
	Gain step error	20 Hz to 20 kHz	-0.1		+0.1	dB
SNR	Signal to noise ratio	A-weighted gain = 0 dB VDD _{SP} = 1.6 V		96.5		dB
V _{NOISE}	Output noise level	Non A-weighted Gain ≤ -15 dB 20 Hz to 20 kHz		6		μV
THD+N	Total harmonic distortion plus noise	VDD _{SP} = 1.6 V -1 dBFS 44.1 kHz slave mode R _{LOAD} > 2 kΩ		-86		dB
		VDD _{SP} = 1.6 V -1 dBFS 32 kHz PLL mode R _{LOAD} > 2 kΩ		-80		dB
PSRR with respect to VDD _{SP}	Power supply rejection ratio	20 Hz – 2 kHz	90			dB
		2 kHz – 20 kHz	70			dB

Table 16: True ground charge pump

HPCSP and HPCSN						
Parameter	Description	Conditions	Min	Typ	Max	Unit
VDDCSP	Positive rail output	CP_MOD = 11 CP_MOD = 10		VDD_A VDD_A / 2		V
VDDCSN	Negative rail output	CP_MOD = 11 CP_MOD = 10		-VDD_A -(VDD_A / 2)		V
	Flyback capacitor	One capacitor		1.0		μF
	Reservoir capacitors	Two capacitors		1.0		μF

Table 17: True ground headphone amplifier

From DAC_L/DAC_R to (HP_L/HP_R)						
Parameter	Description	Conditions	Min	Typ	Max	Unit
V _{MAX}	Full-scale output signal	No load		1.6xVDD_A		V _{PP}
	DC output offset	HP Gain < -30 dB			100	μV
P _{MAX}	Maximum power per channel	VDD_A = 1.6 V THD < 0.1 % R _{LOAD} =16 Ω, 1 kHz		L = 23 R = 23		mW _{RMS}
		VDD_A = 1.8 V THD < 0.1 % R _{LOAD} =16 Ω, 1 kHz		L = 29 R = 29		mW _{RMS}
		VDD_A = 2.5 V THD < 0.1 % R _{LOAD} =16 Ω, 1 kHz		L = 67 R = 67		mW _{RMS}
R _{LOAD} L _{LOAD} C _{LOAD}	Load impedance		13	16	400 500	Ω μH pF
	Frequency response	±0.5 dB	20		20k	Hz
	Amplitude ripple	20 Hz to 20 kHz	-0.5		+0.5	dB
	Programmable gain		-56		+6	dB
	Mute attenuation			70		dB
	Programmable gain step size			1.0		dB
	Absolute gain accuracy	0 dB @ 1 kHz	-0.8		+0.8	dB
	Input gain L/R-mismatch	20 Hz to 20 kHz	-0.1		+0.1	dB
	Input gain step error	20 Hz to 20 kHz	-0.1		+0.1	dB
SNR	Signal to noise ratio	A-weighted gain = 0 dB VDD_A = 2.5 V VDD_A = 1.8 V R _{LOAD} =16 Ω		100 98		dB
V _{NOISE}	Output noise level	20 to 20 kHz, non A-weighted gain < -20 dB			2.5	μVrms
THD+N	Total harmonic distortion plus noise	VDD_A = 1.6 V -5 dBFS R _{LOAD} =16 Ω		-87		dB
PSRR with respect to VDD_A	Power supply rejection ratio	20 Hz – 2 kHz 2 kHz – 20 kHz	70 50			dB

10 Clock Generation

Table 18: MCLK input

Parameter	Description	Conditions	Min	Typ	Max	Unit
	Input amplitude	MCLK squarer enabled MCLK squarer disabled	0.3 0.9×VDD_IO		VDD_IO VDD_IO	V
	Input impedance	DC impedance > 10 MΩ	300 0.5	1	2	Ω pF

Note 8 MCLK squarer enabled specification assumes an input frequency of 13 MHz

11 Phase Locked Loop

Table 19: PLL mode

Parameter	Description	Conditions	Min	Typ	Max	Unit
J _A	MCLK input jitter	Absolute jitter (rms) (Note 10)			500	ps
F _{IN}	Input frequency	Normal mode 32 kHz mode	2 (Note 9)	5 - 50 32.768	50	MHz kHz
	SRM tracking range	DAI slave mode WCLK frequency variation	-4		4	%
	SRM tracking rate	DAI slave mode WCLK drift rate			50	ppm/s

Note 9 See section 13.28 for further details on using an MCLK frequency between 2 MHz and 5 MHz

Note 10 Jitter in the 100 Hz to 40 kHz band

Table 20: Bypass mode

Parameter	Description	Conditions	Min	Typ	Max	Unit
J _A	MCLK input jitter	Absolute jitter (rms) (Note 10)			500	ps
F _{IN}	Input frequency	Sample frequency: 11.025, 22.05, 44.1, 88.2 kHz 8, 12, 16, 24, 32, 48, 96 kHz		11.2896 12.288		MHz

12 Digital Interfaces

Table 21: I/O characteristics

Parameter	Description	Conditions	Min	Typ	Max	Unit
V _{IH}	SCL, SDA, Input high voltage		0.7*VDD_IO			V
V _{IL}	SCL, SDA, Input low voltage				0.3*VDD_IO	V
V _{IH}	MCLK, BCLK, WCLK, DATIN, DATOUT Input high voltage		0.7*VDD_IO			V
V _{IL}	MCLK, BCLK, WCLK, DATIN, DATOUT Input low voltage				0.3*VDD_IO	V
V _{oL} @3 mA	SDA Output low voltage				0.24	V

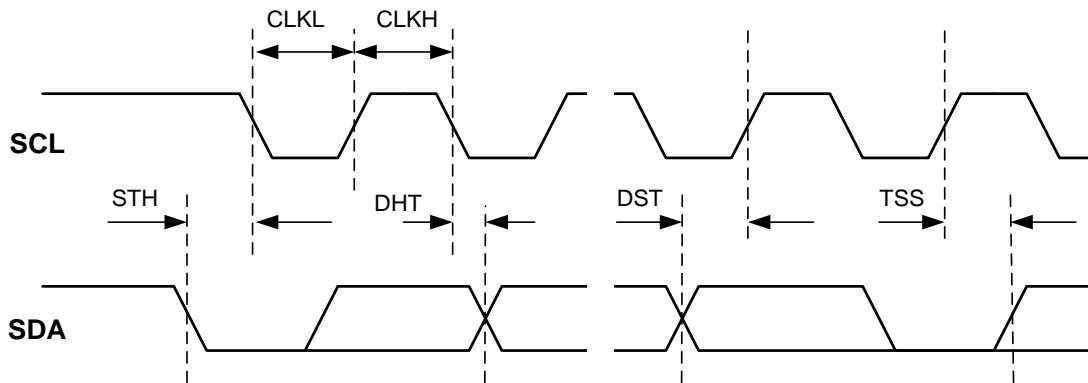

Figure 4: I2C bus timing

Table 22: I2C control bus (VDD_IO = 1.8 V)

Parameter	Description	Conditions	Min	Typ	Max	Unit
	Bus free time STOP to START		500			ns
	Bus line capacitive load				150	pF
Standard/Fast Mode						
	SCL clock frequency		0		1000	kHz
	Start condition setup time		260			ns
STH	Start condition hold time		260			ns
CLKL	SCL low time		500			ns
CLKH	SCL high time		260			ns
	SCL rise/fall time	Input requirement			1000	ns
	SDA rise/fall time	Input requirement			300	ns
DST	SDA setup time		50			ns
DHT	SDA hold time		0			ns
TSS	Stop condition setup time		260			ns
High-Speed Mode						
	SCL clock frequency		0		3400	kHz
	Start condition setup time		160			ns
STH	Start condition hold time		160			ns
CLKL	SCL low time		160			ns
CLKH	SCL high time		60			ns
	SCL rise/fall time	Input requirement			160	ns
	SDA rise/fall time	Input requirement			160	ns
DST	SDA setup time		10			ns
DHT	SDA hold time		0			ns

TSS	Stop condition setup time	160			ns
-----	---------------------------	-----	--	--	----

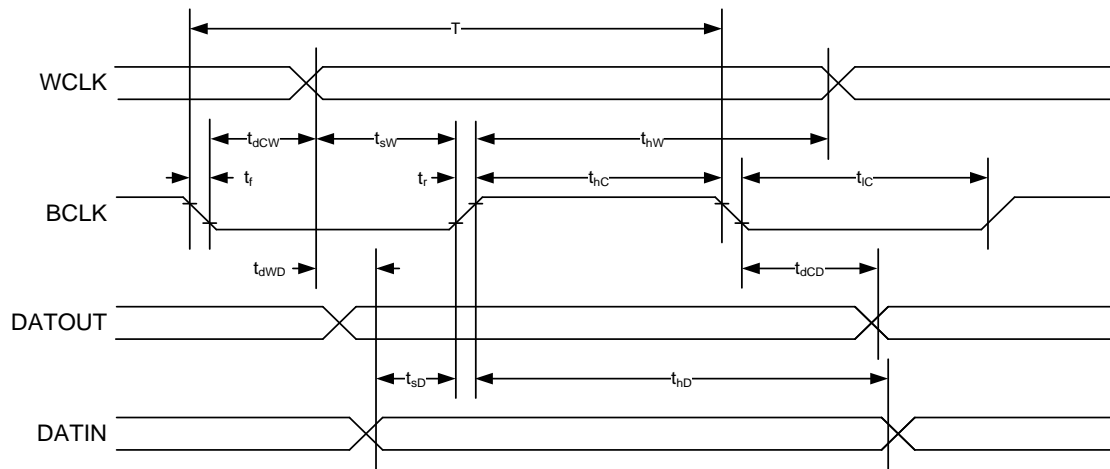

Figure 5: Digital audio interface timing diagram

Note 11 Diagram shown is valid for all modes except DSP. For DSP mode the BCLK signal is inverted

Table 23: Digital audio interface timing (I2S/DSP in master/slave mode)

Symbol	Parameter	Conditions (VDD_IO = 1.8 V)	Min	Typ	Max	Unit	
	Input impedance	DC impedance > 10 MΩ	300 1.0		2.5	Ω pF	
T	BCLK period		75			ns	
t _r	BCLK rise time				8	ns	
t _f	BCLK fall time				8	ns	
t _{hC}	BCLK high period		40 %		60 %	T	
t _{iC}	BCLK low period		40 %		60 %	T	
t _{dCW}	BCLK to WCLK delay		-30 %		+30 %	T	
t _{dCD}	BCLK to DATOUT delay		-30 %		+30 %	T	
t _{hW}	WCLK high time	DSP mode	100 %			T	
		Non-DSP mode	Word length (Note 12)			T	
t _{iW}	WCLK low time	DSP mode	100 %			T	
		Non-DSP mode	Word length (Note 13)			T	
t _{sW}	WCLK setup time	Slave mode	7			ns	
t _{hW}	WCLK hold time	Slave mode	2			ns	
t _{sD}	DATIN setup time		7			ns	
t _{hD}	DATIN hold time		2			ns	
t _{dWD}	DATOUT to WCLK delay		DATOUT is synchronised to BCLK				

Note 12 WCLK must be high for at least the word length number of BCLK periods

Note 13 WCLK must be low for at least the word length number of BCLK periods

12.1 Codec Start-Up Time

After the audio system controller has been enabled using SYSTEM_MODES_INPUT and SYSTEM_MODES_OUTPUT, the start-up times for the various codec paths are as specified below:

Table 24: Codec start-up times

Source	Output	Comment	Min	Typ	Max	Unit
	VMID	VMID > 90 % of final value 1 μF capacitor		25		ms
Any analogue input or DAC_L/R	HP_L HP_R	PLL bypass or PLL normal mode	200	200		ms
Any analogue input or DAC_L/R	HP_L HP_R	PLL SRM or PLL 32 kHz mode		500		ms

Ultra-Low Power Stereo Codec

Source	Output	Comment	Min	Typ	Max	Unit
Any analogue input or DAC_L/R	SP_P SP_N	PLL bypass or PLL normal mode		250		ms
Any analogue input	ADC_L ADC_R	PLL bypass or PLL normal mode		200		ms
Any analogue input	ADC_L ADC_R	PLL SRM or PLL 32 kHz mode		600		ms

13 Functional Description

13.1 General Description

DA7212 is an ultra-low-power audio CODEC with true ground headphone drivers, mixing capability, and digital audio enhancement. It offers Hi-Fi audio quality with class-leading power consumption for portable media and embedded applications.

Featuring a high efficiency headphone amplifier and minimum supply voltage of 1.6 V, the ultra-low 3.1 mW quiescent power consumption extends music playback time for battery-operated equipment.

Control and data interfaces are supplied from a dedicated VDD_IO rail. For compatibility with higher I/O levels, an extended voltage range up to 3.6 V can be selected.

The integrated PLL uses a fractional-N architecture that supports frequencies from 2 MHz to 50 MHz. Standard mobile phone/USB system clock frequencies are supported, and audio data synchronisation is supported even when no master clock is available.

The DA7212 has a stereo pair of single-ended line inputs as well as two microphone inputs, each of which can be configured as single-ended or differential. Both line and microphone signals can be routed to the ADC or directly to the output mixers via a bypass path. In addition, the DA7212 supports both single and dual-channel digital microphone inputs by routing the digital signals directly to the ADC digital filters.

Input and output mixers with stereo-to-mono conversion also support mono configurations such as single speaker outputs.

Three output drivers are available in the output stage of the DA7212. A stereo true-ground amplifier directly drives standard 3-wire 16 ohm headphones while a differential mono speaker amplifier is capable of driving 1.2 W into 8 ohms.

Audio enhancement functions are performed digitally including programmable high-pass filtering, 5-band EQ, noise-gate and an AGC with configurable attack and decay parameters.

The multislots I2S/PCM Digital Audio Interface (DAI) supports all common sample rates between 8 kHz and 96 kHz in master or slave modes.

The CODEC register space can be accessed via the I2C interface of DA7212 on the default 7-bit address 0x1A.

DA7212 implements a unique Smart Controller that enables easy configuration of the Codec for different application scenarios, thereby reducing the number of register writes needed for each case. The Smart Controller runs automatically once enabled, and is optimised to allow pop-free and click-free power-up and power-down operation.

13.2 Input Signal Chain

The DA7212 has a stereo pair of single-ended line inputs as well as two microphone inputs that can each be configured as single-ended or differential. Both line and microphone signals can be routed to the ADC or directly to the output mixers via a bypass path. In addition, the DA7212 supports both single and dual channel digital microphone inputs by routing the digital signals directly to the ADC digital filters. The input routing paths and input amplifier gain ranges are illustrated in [Figure 6](#).

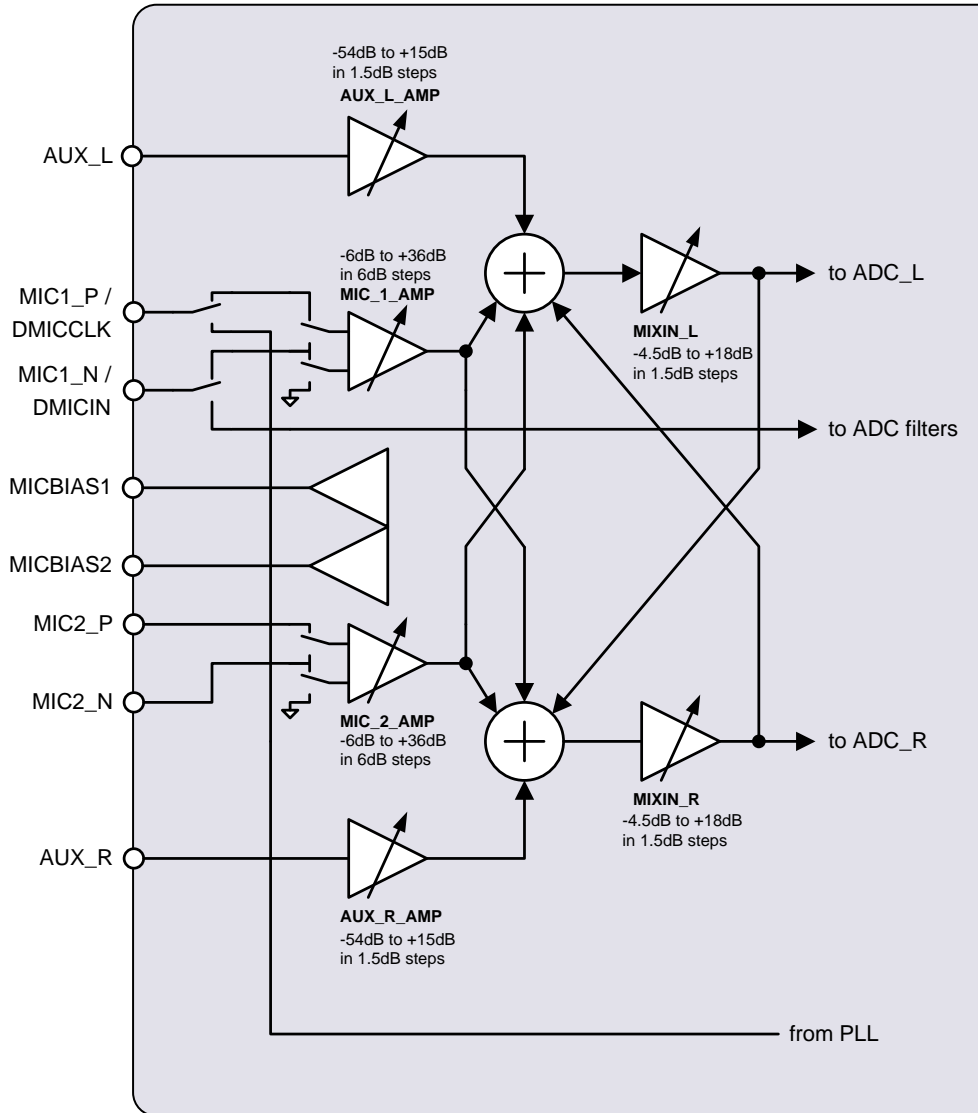

Figure 6: Audio input routing and gain ranges

13.3 Microphone Inputs

The DA7212 includes two pairs of analogue microphone inputs that can be connected in three ways:

- fully differential mode for improved common mode noise rejection
- single ended or pseudo-differential mode by connecting MIC1_N or MIC2_N to GND (see Figure 7). The microphone source is specified using MIC_1_AMP_IN_SEL and MIC_2_AMP_IN_SEL
- single ended or pseudo-differential mode by connecting MIC1_P or MIC2_P to GND (see Figure 7). The microphone source is specified using MIC_1_AMP_IN_SEL and MIC_2_AMP_IN_SEL

The microphone PGAs are enabled by the MIC_1_AMP_EN / MIC_2_AMP_EN controls and can be muted via MIC_1_AMP_MUTE_EN / MIC_2_AMP_MUTE_EN. For maximum flexibility, each microphone channel includes an individual gain setting (MIC_1_AMP_GAIN / MIC_2_AMP_GAIN controls) that has a range of -6 dB to +36 dB in 6 dB steps. The currently active gain setting of each microphone is stored in MIC_1_GAIN_STATUS and MIC_2_GAIN_STATUS.

A maximum analogue gain from microphone to ADC input of +54 dB with a resolution of 1.5 dB can be selected.

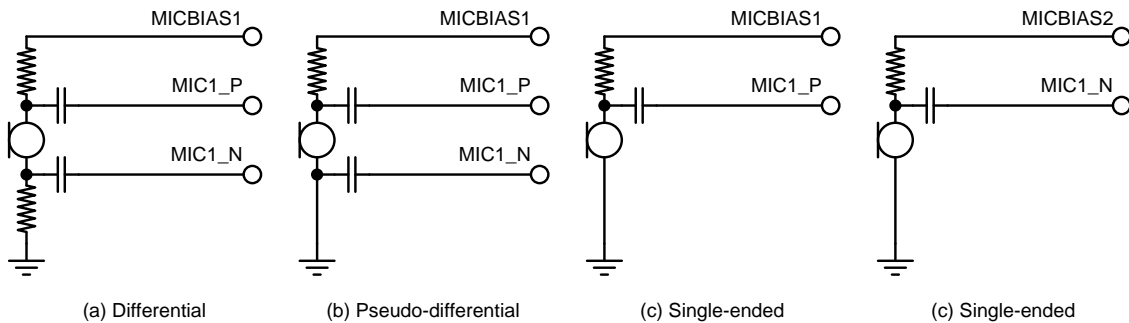

Figure 7: Typical microphone application for MIC1 (MIC2 is similar)

Standard electret microphones can be supplied from an embedded microphone bias regulator, enabled using the MICBIAS2_EN control bit. Two separate outputs are available on either the MICBIAS1 pin or the MICBIAS2 pin. These are enabled using the MICBIAS2_EN and MICBIAS1_EN controls. The voltage on the MICBIAS pins is set to 1.6 V, 2.2 V, 2.5 V or 3.0 V by the MICBIAS2_LEVEL and MICBIAS1_LEVEL controls. The microphone bias generates an ultra-low-noise voltage to feed several electret microphones with up to 2 mA.

13.4 Digital Microphones

DA7212 implements a digital microphone interface via a clock output (shared pin with MIC1_P) and a serial data input (shared pin with MIC1_N). The serial data is a sigma delta sampled bitstream.

MICBIAS1 can be used to power the digital microphone, but it must be enabled because it is MICBIAS1 that supplies the digital microphone pins.

The clock and data pins are shared with two analogue microphone inputs. This allows DA7212 to record from single or dual channel digital microphones, or from conventional mono/stereo analogue microphones.

The clock frequency can be selected to be either 3.072 MHz or 2.8224 MHz, or 1.536 MHz or 1.4112 MHz by using DMIC_CLK_RATE control.

Ultra-Low Power Stereo Codec

Single channel and dual channel digital microphone modules are supported. The dual channel modules change the output data on both the rising and the falling edges of the clock, as illustrated in Figure 7. In this case DMIC_SAMPLEPHASE must be set to zero in order to enable the sample detection at the edges of the clock. Each DMIC input is enabled via DMIC_L_EN / DMIC_R_EN and is associated with a clock edge via DMIC_DATA_SEL control.

A digital microphone requires a decimation filter to reconstruct the signal at the required sampling rate. The ADC decimation filters are re-used for this purpose, so either digital microphones or analogue sources may be used for recording at any one time.

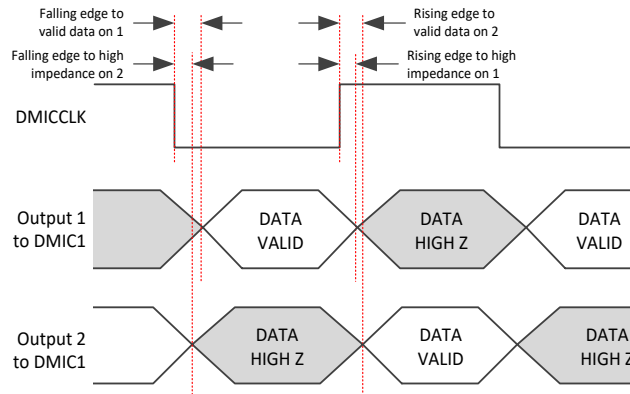

Figure 8: Digital microphone timing example

13.5 Auxiliary Inputs

Standard analogue sources (for example FM radio) are supported via the AUX stereo line inputs. Auxiliary inputs are enabled by AUX_L_AMP_EN / AUX_R_AMP_EN. They can be summed with each other, and with the microphone paths, which enables flexible audio mixing.

Each channel includes individual gain settings in 1.5 dB steps from -54 dB to +15 dB using AUX_L_AMP_GAIN and AUX_R_AMP_GAIN. The auxiliary amplifiers can be muted by asserting AUX_L_AMP_MUTE_EN and AUX_R_AMP_MUTE_EN.

Changes in gain can be synchronised with zero-crossing by asserting the AUX_L_AMP_ZC_EN and AUX_R_AMP_ZC_EN bits. If no zero-crossing is detected within approximately 85 ms, the gain change is applied unconditionally. The sensitivity of the zero-cross detector is maximised by automatic selection of whether the zero-cross detection is performed at the input to the AUX amplifier, or the output from it. This is configured using the AUX_L_AMP_ZC_SEL and AUX_R_AMP_ZC_SEL controls.

Smooth changes in gain are enabled by asserting the AUX_L_AMP_RAMP_EN and AUX_R_AMP_RAMP_EN controls. If the ramp controls are asserted, the rate of ramping is specified by the GAIN_RAMP_RATE control. Any zero-cross activation is over-ridden if gain ramping is set.

The currently active AUX_L_GAIN and AUX_R_GAIN settings are stored in the AUX_L_GAIN_STATUS and AUX_R_GAIN_STATUS controls.

13.6 Input Mixers

The DA7212 has two second level input amplifiers (MIXIN_L and MIXIN_R) that mix the analogue inputs as well as providing up to 18 dB extra gain. They are enabled by asserting the controls MIXIN_L_AMP_EN and MIXIN_R_AMP_EN. Gain can be controlled in 1.5 dB steps from 4.5 dB to +18 dB using the MIXIN_L_GAIN and MIXIN_R_GAIN register bits.

Zero-crossing can be enabled by asserting MIXIN_L_AMP_ZC_EN or MIXIN_R_AMP_ZC_EN. If no zero crossing is detected within approximately 85 ms, the gain change is applied unconditionally. Smooth changes in gain are performed by asserting the MIXIN_L_AMP_RAMP_EN and MIXIN_R_AMP_RAMP_EN controls. If the ramp controls are asserted, the rate of ramping is specified by the GAIN_RAMP_RATE control. Any zero-cross activation is over-riden if gain ramping is set.

The left mixer accepts inputs from AUX_L_AMP and from either or both of the microphone PGAs (MIC_1_AMP and MIC_2_AMP), as well as from the right mixer MIXIN_R for stereo-to-mono conversion. Similarly the right mixer accepts inputs from AUX_R_AMP and from either or both of the microphone PGAs (MIC_1_AMP and MIC_2_AMP), as well as from the left mixer MIXIN_L for stereo-to-mono conversion. Input channel selection is determined by MIXIN_L_MIX_SELECT and MIXIN_R_MIX_SELECT.

The mixers can be muted using the MIXIN_L_AMP_MUTE_EN and MIXIN_R_AMP_MUTE_EN controls. The currently active gain settings are stored in MIXIN_L_AMP_GAIN_STATUS and MIXIN_R_AMP_GAIN_STATUS registers.

13.7 Stereo Audio ADC

DA7212 includes a low power 24-bit high quality audio ADC that supports sampling rates from 8 kHz to 96 kHz. The sample rate is specified using the SR register.

The ADC can be enabled and disabled on either channel using ADC_L_EN and ADC_R_EN, thereby providing the opportunity to save power during mono operation.

The ADC channels offer a configurable digital gain from -83.25 dB to +12 dB in 0.75 dB steps after the digital conversion. Individual gain settings can be programmed via controls ADC_L_DIGITAL_GAIN_STATUS and ADC_R_DIGITAL_GAIN_STATUS. The currently active gain settings are stored in ADC_L_GAIN_STATUS and ADC_R_GAIN_STATUS registers.

Muting, and the ramping of digital gain changes, can be controlled using the dedicated ADC_L_CTRL and ADC_R_CTRL registers. If the ramping is enabled using the control bits ADC_L_RAMP_EN and ADC_R_RAMP_EN, the rate of the ramping is controlled using GAIN_RAMP_RATE.

To enable saturation-free signals with maximum signal to noise ratios, the input levels of the ADC are adjusted with second level PGAs that are enabled with controls MIXIN_L_AMP_EN and MIXIN_R_AMP_EN. The signal routing and mix are configured using the MIXIN_L_SELECT and MIXIN_R_SELECT registers.

On the dedicated MIXIN_L_CTRL and MIXIN_R_CTRL registers, settings such as gain changes at zero-cross (for smooth volume changes), ramping of gain changes at signal zero cross ramping of gain changes, and mute can be configured. If the ramping is enabled using the control bits MIXIN_L_AMP_RAMP_EN and MIXIN_R_AMP_RAMP_EN, the speed of the ramp can be configured on GAIN_RAMP_RATE.

13.8 Automatic Level Control

For improved sound recordings of signals with a large volume range, the DA7212 offers a fully-configurable automatic recording level control (ALC) for microphone inputs. This is enabled via the ALC_L_EN and ALC_R_EN controls, and can be enabled independently on either left or right channel. It is recommended that the ALC is only enabled in stereo as this applies the same gain to both channels and so protects the pan of stereo signals.

The ALC monitors the digital signal after the ADC and adjusts the microphones' analogue and digital gain to maintain a constant recording level, whatever the analogue input signal level.

Operation of ALC is illustrated in Figure 9. When the input signal volume is high, the ALC system will reduce the overall gain until the output volume is below the specified maximum value. When the input signal volume is low, the ALC will increase the gain until the output volume increases above the specified minimum value. If the output signal is within the desired signal level (between the specified minimum and maximum levels), the ALC does nothing.

The maximum and the minimum thresholds that trigger a gain change of the ALC are programmed by the ALC_THRESHOLD_MAX and ALC_THRESHOLD_MIN controls.

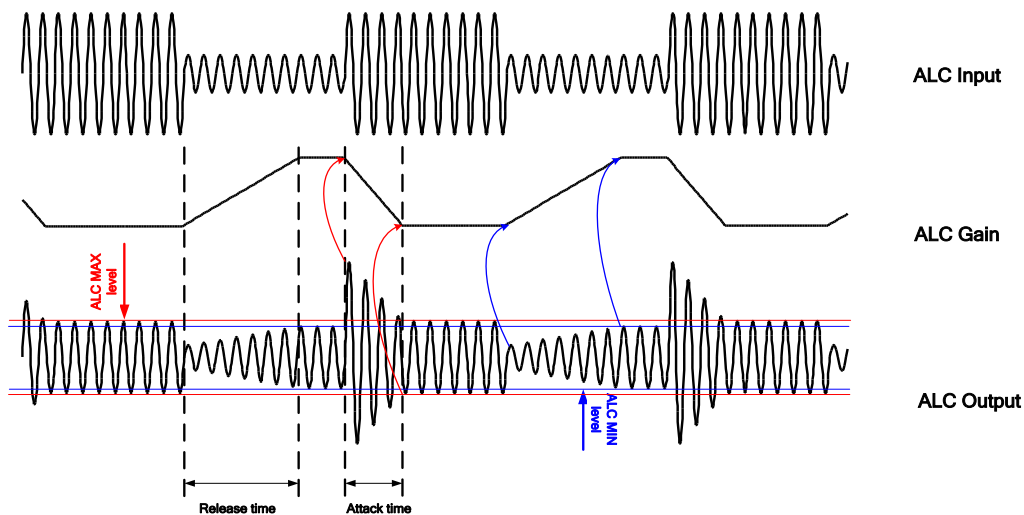

Figure 9: Principle of operation of the ALC

The total gain is made up of an analogue gain, which is applied to the microphone PGAs, and a digital gain, which is implemented in the filtering stage. The ALC block monitors and controls the gain of the microphone PGAs and the ADC. Note that although the ALC is controlling the gain, it does not modify any of the registers MIC_1_AMP_GAIN, MIC_2_AMP_GAIN, ADC_L_DIGITAL_GAIN and ADC_R_DIGITAL_GAIN. These registers are ignored while the ALC is in operation.

The minimum and maximum levels of digital gain that can be applied by the ALC are controlled using ALC_ATTEN_MAX and ALC_GAIN_MAX.

Similarly the minimum and maximum levels of analogue gain are controlled by ALC_ANA_GAIN_MIN and ALC_ANA_GAIN_MAX. The rates at which the gain is changed are defined by the attack and decay rates in register ALC_CTRL2. When attacking, the gain decreases with ALC_ATTACK rate. When decaying, the gain increases with ALC_RELEASE rate.

Ultra-Low Power Stereo Codec

The hold-time is defined by [ALC_HOLD](#) in the ALC_CTRL3 register. This controls the length of time that the system maintains the current gain level before starting to decay. This prevents unwanted changes in the recording level when there is a short-lived 'spike' in input volume, for example when recording speech.

Typically the attack rate should be much faster than the decay rate, as it is necessary to reduce rapidly increasing waveforms as quickly as possible, whereas fast release times will result in the signal appearing to 'pump'. The ALC also has an anti-clipping function that applies a very fast attack rate when the input signal is close to full-range. This prevents clipping of the signal by reducing the signal gain at a faster rate than would normally be applied. The anti-clip function is enabled using [ALC_ANTICLIP_EN](#), and the threshold above which it is activated is set in the range 1/128 full-scale to full-scale using [ALC_ANTICLIP_LEVEL](#).

A recording Noise-Gate feature is provided to avoid increasing the gain of the channel when there is no signal, or when only a noise signal is present. Boosting a signal on which only noise is present is known as 'noise pumping'. The Noise-Gate prevents this. Whenever the level of the input signal drops below the noise threshold configured in [ALC_NOISE](#), the channel gain remains constant.

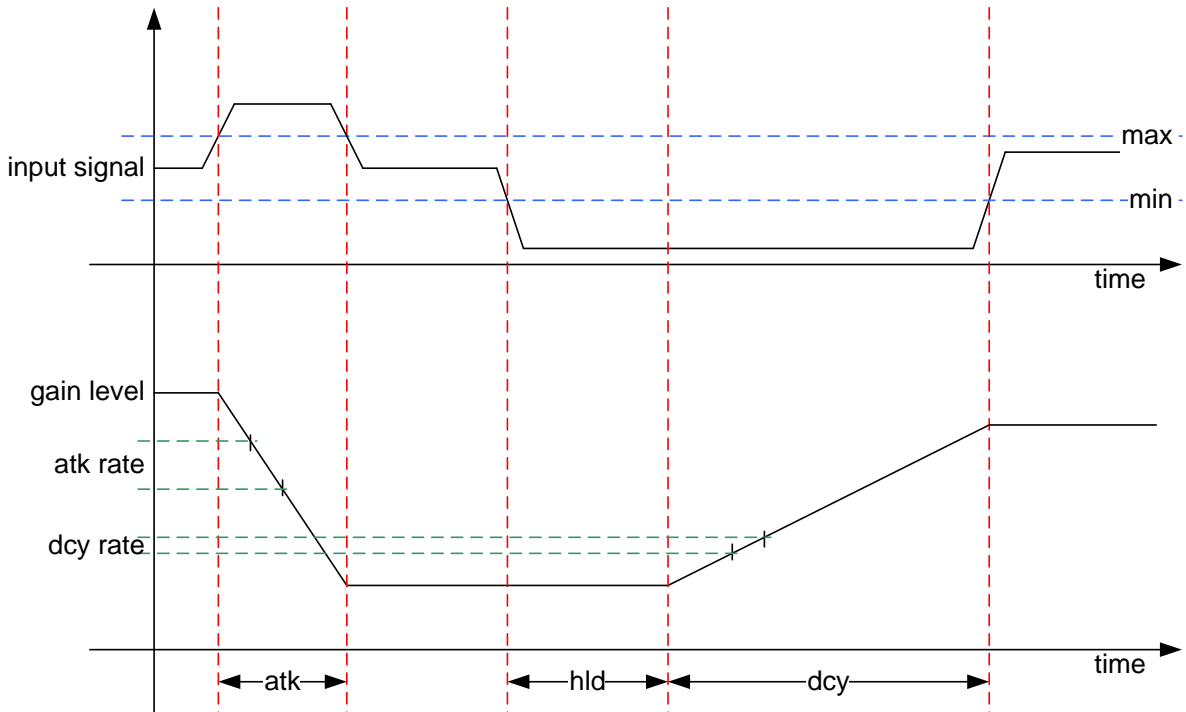

Figure 10: Attack, delay and hold parameters

13.9 Beep Generator and Controller

The DA7212 has two sine wave generators (SWG). Each SWG can generate an audio frequency from 10 Hz to 12 kHz with a 12.288 MHz system clock (or from 10 Hz to 11.02 kHz with a 11.288 MHz system clock). The output frequency of each SWG can be specified with a 10Hz step size using the `FREQ1_L` and `FREQ1_U` registers for SWG 1, and `FREQ2_L` and `FREQ2_U` for SWG 2.

For all Output Frequency calculations,

$$\text{FREQ}[15:8] = \text{FREQn_U}$$

$$\text{FREQ}[7:0] = \text{FREQn_L}$$

For sample rates (SR) = 8/12/16/24/32/48/96 kHz,

$$\text{FREQ} = (2^{16} * (f_{\text{Hz}}/12)) - 1$$

For sample rates (SR) = 11.025/22.05/44.4/88.2 kHz,

$$\text{FREQ} = (2^{16} * (f_{\text{Hz}}/11.025)) - 1$$

The SWGs have a programmable gain that can be set in 3 dB steps from 0 dB to 45 dB using the `GAIN` register field. The gain setting applies equally to both SWGs.

The beep generator generates beeps that can be a single tone from either SWG (register `SWG_SEL` = 1 or `SWG_SEL` = 2), or a mix of two tones from the two SWGs (register `SWG_SEL` = 0 or `SWG_SEL` = 3). The beep generator can also output standard DTMF keypad values (listed in Table 4) by asserting the `DTMF_EN` register bit.

Note that output from the beep generator is mixed into the DAI to DAC path. This means that if the source path for `DAC_L` or `DAC_R` is selected to be `ADC_L` or `ADC_R` (registers `0x2A[5:4]` and `0x2A[1:0]`), the beep generator is omitted from the signal path.

Table 25: DTMF keypad frequencies

Frequency 1 (Hz)	Frequency 2 (Hz)			
	697	770	852	941
1209	1	2	3	A
1336	4	5	6	B
1477	7	8	9	C
1633	*	0	#	D

The beep tone On and Off periods are specified using the `BEEP_ON_PER` and `BEEP_OFF_PER` register fields. Beep-On and Beep-Off periods can be configured in 10 ms steps from 10ms to 200 ms, and in 50 ms steps from 250 ms to 2000 ms. The Beep-On period can also be configured as continuous. The number of beep cycles is configured using the `BEEP_CYCLES` register field.

The tone generator is started by asserting the `START_STOPN` register bit, and is halted by clearing it. If `START_STOPN` is cleared, beep generation terminates on completion of the current beep-cycle, or at the next zero-cross if in continuous mode.

The `START_STOPN` register bit is cleared automatically once the programmed number of beeps has completed. In continuous-beep mode (`BEEP_CYCLES` = 6 or 7, or `BEEP_ON_PER` = 63), the tone generator is switched off by clearing `START_STOPN`.

13.10 Output Signal Chain

The DA7212 has two audio outputs. These are a stereo Class-G headphone driver, and a mono Class-AB speaker driver. Two output mixers allow mixing of signals from the DACs and the analogue bypass paths, with output going to any or all of the three output PGAs. These output paths are illustrated in Figure 11.

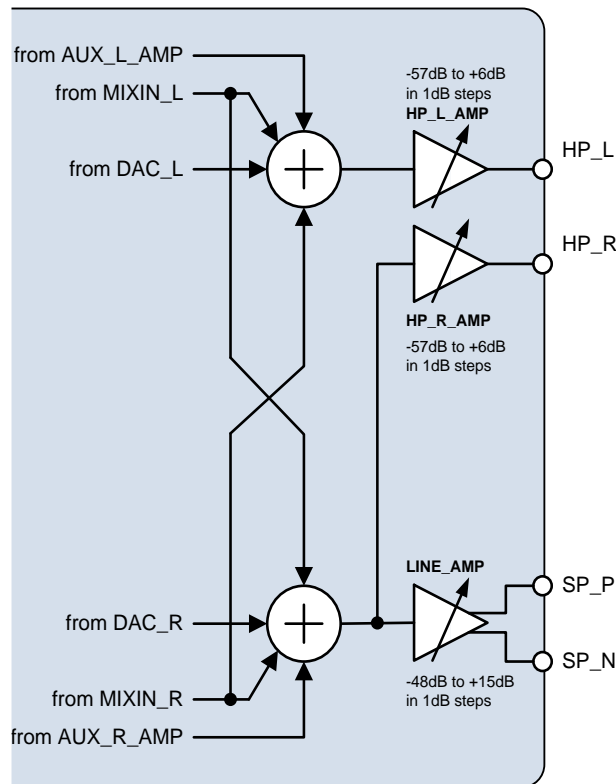

Figure 11: Analogue output signal paths and gain ranges

13.11 Stereo Audio DAC

The integrated stereo DAC is suitable for high quality audio playback by MP3 players and by portable multimedia players of all kinds.

The left and right channels of the DAC can be individually enabled using controls DAC_L_EN and DAC_R_EN.

Each channel includes individual gain settings that are controllable in 0.75 dB steps from -78 dB to 12 dB using DAC_L_DIGITAL_GAIN_STATUS and DAC_R_DIGITAL_GAIN_STATUS. The currently active gain settings are stored in DAC_L_GAIN_STATUS and DAC_R_GAIN_STATUS registers.

On the dedicated DAC_L_CTRL and DAC_R_CTRL registers, settings such as mute and ramping of gain changes can be configured. If ramping is enabled using the control bits DAC_L_RAMP_EN or DAC_R_RAMP_EN, the rate of the ramping can be controlled using GAIN_RAMP_RATE.

A digital high-pass filter for each DAC channel is implemented with a 3 dB cut-off frequency controlled by DAC_AUDIO_HPF_CORNER. The high-pass filter is enabled by control DAC_HPF_EN. After Reset, the high pass filters for both channels are enabled by default.

13.12 Output Mixer

For playback, the output mixer amplifier is enabled using MIXOUT_L_AMP_EN and MIXOUT_R_AMP_EN. The audio signal can be mixed from all sources, and can be output simultaneously to both headphones and speakers. The mixing takes place only after asserting the control MIXOUT_L_MIX_EN and MIXOUT_R_MIX_EN.

The output mixer is configured using register MIXOUT_L_SELECT and MIXOUT_R_SELECT. This output-mixer control is independent of the input path, so recording of one audio signal while listening to another signal such as FM Radio or an MP3 file is possible. The playback sound can be mixed with background signals or with inverted background microphone signals (side tone) to enable a basic headphone environmental noise reduction, or to compensate for unwanted damping of environmental sound while listening with sealed headphones. Playback signals coming from the AUX or microphone input channels can be individually inverted before being mixed out to the left and right channel (see MIXOUT_L_SELECT and MIXOUT_R_SELECT registers).

A stereo to mono conversion can be implemented by using either the input or the output mixer. This allows direct feeding of high power speaker amplifiers and other mono devices with the complete audio content.

13.13 Headphone Amplifier

The headphone Class G amplifiers offer 'true ground' technology, which allows cost and space optimisation by removing the need for bulky headphone-coupling capacitors. This also enhances the bass performance, which is typically reduced by conventional AC-coupling. In comparison to alternative approaches like 'phantom ground', 'true ground' technology generates real ground-centred output signals, which provide common GND as required for Mini-USB connectors and CEA 936 A-compliant interfaces. An embedded offset compensation circuit suppresses click and pop noise during start-up and dynamic supply voltage adjustments.

Integrated short circuit protection enables a 'resistors free' connection to a standard audio jack, to achieve a maximum output power of up to 67 mW per channel (referenced to VDD_A). Headphone load impedance is typically 16 Ω , but the paths can also be used as volume controlled lineout signals for external speaker amplifiers and audio devices. The headphone Class G amplifiers are supplied from the positive VDD_A rail via a capacitive charge pump that generates the negative rail required for 'true ground' mode. For improved power efficiency, the headphone supply voltage levels are dynamically adjusted between $\pm VDD_A$ and $\pm VDD_A/2$ to match the levels of the left and right headphone signals.

The headphone amplifiers are enabled with controls HP_L_AMP_EN and HP_R_AMP_EN. For optimum pop and click performance when switching the amplifier On and Off, the headphone amplifier provides a high impedance mode that can be enabled via HP_L_AMP_OE / HP_R_AMP_OE.

Balance is controlled by programming the left and right gains separately. The gain of each headphone channel can be programmed independently in steps of 1.0 dB from +6 dB down to -57 dB using controls HP_L_AMP_GAIN / HP_R_AMP_GAIN.

Settings such as mute, gain changes at signal zero cross (for smooth volume changes), and the ramping of gain changes are controlled using the dedicated HP_L_CTRL and HP_R_CTRL registers. If the ramping is enabled using the control bits HP_L_AMP_RAMP_EN and HP_R_AMP_RAMP_EN, the rate of the ramping is controlled using GAIN_RAMP_RATE.

For smooth volume changes, the gain update can be synchronised to audio signal zero-crossings using HP_L_AMP_ZC_EN and HP_R_AMP_ZC_EN. If no zero crossing is detected within approximately 85 ms, the gain change is applied unconditionally. The left and right channels are synchronised independently.

Ultra-Low Power Stereo Codec

13.14 Speaker Amplifier

The differential lineout channel can be used to directly drive mini speakers with a nominal impedance $\geq 8 \Omega$. For highest efficiency and speaker output power, a direct supply from the battery is supported via a separate supply pin. This amplifier offers individually programmable volume control in 1.0 dB steps from +15 dB to 48 dB using LINE_AMP_GAIN.

On the dedicated LINE_CTRL register, settings such as mute, tri-state output mode and ramping of gain changes can be configured. If ramping is enabled via control bit LINE_AMP_RAMP_EN, the rate of the ramping can be configured on GAIN_RAMP_RATE.

The differential speaker amplifier can be used to drive mini-speakers with an impedance of 8 Ω or higher. A direct supply from the battery is provided by the VDD_SP pin. This allows maximum speaker power and a wide operating range from 5.0 V down to 1.0 V.

The mono lineout/speaker amplifier is enabled by asserting LINE_AMP_EN. Gain can be set in the range -48 dB to +15 dB in 1 dB steps using the LINE_AMP_GAIN control. The speaker amplifier can be muted by asserting LINE_AMP_MUTE_EN.

Smooth updates to line/speaker amplifier gain can be made by asserting LINE_AMP_RAMP_EN. When LINE_AMP_RAMP_EN is asserted, gain updates are made by ramping sequentially through all intermediate gain values.

If the speaker output is not used then VDD_SP can be left unconnected.

13.15 Charge Pump Control

The charge pump is enabled by asserting CP_EN in the CP_CTRL (0x47) register. Once enabled, the charge pump can be controlled manually or automatically. When under manual control (CP_MCHANGE = 00), the output voltage level is directly determined by CP_MOD.

The amount of charge stored, and therefore the voltage generated, by the charge pump is controlled by the charge pump controller (CP_CTRL register). As the power consumed by devices such as amplifiers is proportional to Voltage², significant power savings are available by matching the charge pump's output with the system's power requirement.

Under automatic control, there are three modes of operation that are determined by the CP_MCHANGE setting. All four modes (one manual and three automatic) are described in Table 26.

Table 26: Charge pump output voltage control

Charge pump tracking mode CP_MCHANGE	Charge pump output voltage	Details
00	Manual	The charge pump's output voltage is determined by the settings of CP_MOD.
01	Voltage level depends on the programmed gain setting	The charge pump controller monitors the PGA volume settings, and generates the minimum voltage that is high enough to drive a full-scale signal at the current gain level.
10	Voltage level depends on the DAC signal envelope	The charge pump controller monitors the DAC signal, and generates a voltage that is high enough to drive a full-scale output at the current DAC signal volume level
11	Voltage level depends on the signal magnitude and the programmed gain setting	The charge pump monitors both the programmed volume settings and the actual signal size, and generates the appropriate output voltage. This is the most power-efficient mode of operation.

Ultra-Low Power Stereo Codec

When CP_MCHANGE is set to 10 (tracking DAC signal size, described in Table 26) or CP_MCHANGE is set to 11 (tracking the output signal size), the charge pump switches its supply between the VDD_A rail and the VDD_A/2 rail depending on its power requirements.

When low output voltages are needed, the charge pump saves power by using the lower-voltage VDD_A /2 rail.

The switching point between using the VDD_A rail and the VDD_A/2 rail is determined by the CP_THRESH_VDD2 register setting. The switching points determined by CP_THRESH_VDD2 vary between the two CP_MCHANGE modes, and are summarised in Table 27 and Table 28.

When the charge pump output voltage is controlled manually (CP_MCHANGE = 00) or when it is tracking the PGA gain settings (CP_MCHANGE = 01), the charge pump always takes its supply from VDD_CP.

Table 27: CP_THRESH_VDD2 settings in DAC_VOL mode (CP_MCHANGE = 10)

CP_THRESH_VDD2 setting	Approximate switching point (Note 14)	Notes
0x01	-30 dBFS	Do not use. Very power-inefficient as nearly always VDD/1
0x03	-24 dBFS	Not recommended. Very power-inefficient as nearly always VDD/1
0x07	-18 dBFS	Good to use but not power efficient
0x0E	-12 dBFS	Good to use
0x10	-10 dBFS	Recommended setting
0x3F – 0x13		Not recommended

Table 28: CP_THRESH_VDD2 settings in signal size mode (CP_MCHANGE = 11)

CP_THRESH_VDD2 setting	Approximate switching point (Note 14)	Notes
0x00	Never	Not recommended. Always VDD/1 mode
0x01	Never	Not recommended. Always VDD/1 mode
0x02	-32 dBFS	Not recommended. Very power-inefficient as nearly always VDD/1
0x03	-24 dBFS	Good to use
0x04	-20 dBFS	Good to use
0x05	-17 dBFS	Good to use
0x06	-15 dBFS	Recommended setting
0x07	-13 dBFS	Good to use
0x08	-12 dBFS	Good to use
0x09	-11 dBFS	Good to use
0x0A	-10 dBFS	Good to use
0x0B	-9 dBFS	Not recommended. VDD/2 begins to clip
0x0C	Never	Not recommended. Always VDD/2 mode
0x0D	Never	Not recommended. Always VDD/2 mode
0x0E	Never	Not recommended. Always VDD/2 mode
0x0F	Never	Not recommended. Always VDD/2 mode

Note 14 Full Scale (FS) = 1.6 * VDD_A

13.16 Charge Pump Clock Control

The charge pump on DA7212 requires two clocks (cp_clk and cp_clk2). The cp_clk2 clock runs at a slower frequency than cp_clk. It is cp_clk that actually clocks the charge pump.

To prevent the clocks stopping in an unknown state, there are always two pulses on cp_clk for every one pulse of cp_clk2. This is illustrated in Figure 12.

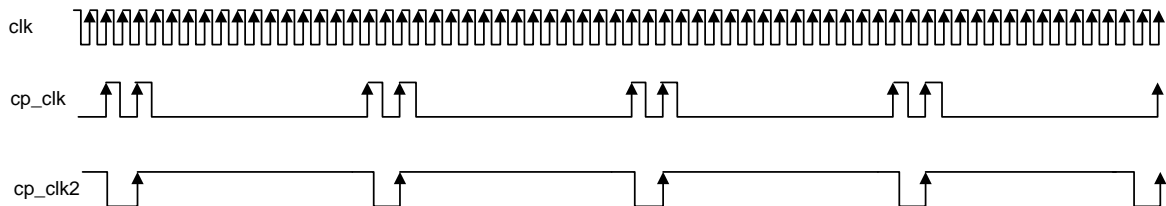

Figure 12: Input (clk) and output clocks (cp_clk and cp_clk2) at CP_FCONTROL = 010

When CP_ANALOGUE_LVL = 00 ('No feedback' – see Section 13.17 for more details), the charge pump's nominal clock rate cp_clk is controlled by CP_FCONTROL, providing a range from 1 MHz (CP_FCONTROL = 000) down to 63 kHz (CP_FCONTROL = 100). With the slower clock rates, quiescent power consumption is lower but the trade-off is a reduced load current, and slower changes to the voltage.

Section 13.17 describes how quiescent power and load current can be varied according to demand.

13.17 Boosting The Charge Pump Using Demand Feedback Control

When CP_ANALOGUE_LVL = 00, the clock frequency for the charge pump is under direct control of the registers as described in [Table 29](#).

When CP_ANALOGUE_LVL = 01 or 10 (11 is reserved and is not used), the demands on the charge pump output are tracked, and the clock frequency is boosted when necessary to give the required output current.

This gives the benefit of a very low (or even zero) quiescent current when the charge pump is not required combined with a maximum output when that is required.

13.17.1 Tracking The Demands On The Charge Pump Output

There are three points at which the demands on the charge pump can be tracked. These tracking points are determined by CP_MCHANGE.

13.17.1.1 CP_MCHANGE = 00 (Manual Mode)

If CP_MCHANGE = 00, the voltage level is controlled by the CP_MOD setting.

13.17.1.2 CP_MCHANGE = 01 (Tracking the PGA Gain Setting)

If CP_MCHANGE = 01, it is the PGA gain setting that is tracked, and which provides the feedback to boost the clock frequency when necessary.

13.17.1.3 CP_MCHANGE = 10 (Tracking the DAC Signal Setting)

If CP_MCHANGE = 01, it is the size of the DAC signal that is tracked, and which provides the feedback to boost the clock frequency when necessary.

13.17.1.4 CP_MCHANGE = 11 (Tracking the Output Signal Magnitude)

If CP_MCHANGE = 01, it is the magnitude of the output signal that is tracked, and which provides the feedback to boost the clock frequency when necessary.

13.17.2 Specifying Clock Frequencies when Tracking the Charge Pump Output Demand

CP_FCONTROL specifies the frequency of the charge pump clock. The frequency is fixed and is set manually if CP_MCHANGE = 00 (see section [13.17.1.1](#)). The available frequency settings are 1 MHz (the absolute maximum), and 500, 250, 125 and 63 kHz.

If CP_MCHANGE not = 00, the charge pump load is monitored and the clock frequency adjusted accordingly to allow the charge pump to supply the required current. Clock frequency varies depending on the charge pump requirements, and the CP_FCONTROL settings specify the minimum frequency at which the clock will run. The maximum frequency is always 1 MHz.

In addition to the CP_FCONTROL settings outlined above, and which specify the minimum clock frequency, there is an extra setting of CP_FCONTROL = 101 which has no minimum frequency. The clock frequency is under the complete control of the tracking and feedback mechanism. The frequency can vary from 0 Hz when there is no load on the charge pump and no component leakage, up to the maximum of 1 MHz.

These settings are all summarised in [Table 29](#).

13.17.3 Controlling the Boost Of the Charge Pump Clock-Frequency

The manner in which the charge pump clock-frequency is boosted is controlled by CP_ANALOGUE_LVL. If CP_ANALOGUE_LVL = 00, there is no feedback to the clock generator, and the frequency remains fixed at the frequency specified by CP_FCONTROL.

13.17.3.1 CP_ANALOGUE_LVL = 01

If CP_ANALOGUE_LVL = 01, the clock frequency is boosted from the base frequency specified in CP_FCONTROL by the insertion of extra clock pulses in to the clock signal as and when required. When no extra pulses are being inserted, the clock frequency remains fixed at the value specified by CP_FCONTROL. The extra clock pulses are inserted in to the clock signal as needed as long as the clock frequency does not exceed its maximum of 1 MHz.

13.17.3.2 CP_ANALOGUE_LVL = 10

If CP_ANALOGUE_LVL = 10, instead of boosting the clock frequency by inserting extra clock pulses as described in section 13.17.3.1, the clock is restarted. By restarting the clock before the next pulse is due, the frequency is effectively increased. The clock frequency can be increased from the minimum frequency specified in CP_FCONTROL, up to the maximum frequency of 1 MHz.

These settings are all summarised in [Table 27](#).

Table 29: Charge pump current load control

		CP_ANALOGUE_LVL (0x47[1:0])			
		00 No current boost	01 Variable current boost (Note 15)	10 Variable current boost (Note 15)	11
CP_FCONTROL (0x96[2:0])	000	1 MHz	1 MHz	1 MHz	Reserved
	001	500 kHz	From 500 kHz to 1 MHz depending on demand	From 500 kHz to 1 MHz depending on demand	Reserved
	010	250 kHz	From 250 kHz to 1 MHz depending on demand	From 250 kHz to 1 MHz depending on demand	Reserved
	011	125 kHz	From 125 kHz to 1 MHz depending on demand	From 125 kHz to 1 MHz depending on demand	Reserved
	100	63 kHz	From 63 kHz to 1 MHz depending on demand	From 63 kHz to 1 MHz depending on demand	Reserved
	101	Reserved	0 Hz to 1 MHz depending on demand	0 Hz to 1 MHz depending on demand	Reserved
	110	Reserved	Reserved	Reserved	Reserved
	111	Reserved	Reserved	Reserved	Reserved

Note 15 Power demand is determined by the PGA gain level if CP_MCHANGE = 01, by the DAC signal level if CP_MCHANGE = 10, or by the output signal level if CP_MCHANGE = 11

13.18 Other Charge Pump Controls

When a higher charge pump output voltage is needed, the charge pump increases its output as the fastest rate possible given the controls and settings in that currently in place. Once the higher output voltage is no longer needed, the charge pump controller waits for a period determined by the CP_TAU_DELAY setting before reducing the output voltage. For best performance Dialog recommend setting CP_TAU_DELAY to 16 ms or greater.

The charge pump limiter is controlled by CP_ON_OFF. The limiter restricts the current flow to the charge pump's capacitors at start-up.

CP_SMALL_SWITCH_FREQ_EN enables a low-load, low-power switching mode.

If CP_SMALL_SWITCH_FREQ_EN is enabled and CP_FCONTROL is set to a value between 000 and 100, any feedback from the analogue level detector results in a switch from low-power to full-power. Full-power is maintained for one CP_TAU_DELAY period after the pulse. Any subsequent pulses restart the CP_TAU_DELAY period.

If CP_FCONTROL = 101, the first feedback from the analogue level detector primes the change to full-power mode. If another pulse occurs within 32 clock cycles of the first feedback from the analogue level detector, full power is enabled for one CP_TAU_DELAY period.

13.19 Digital Signal Processing Engine

The digital signal processing engine includes a configurable audio processor that offers flexible routing and extensive audio enhancement and effects. Linear phase FIR filters perform the DAC interpolation and decimation for the required sample rates. Configurable high-pass filtering (optionally enabled on both ADC and DAC) removes any signal DC offset and can help to filter out wind noise. A 5-band playback equaliser can be configured to suit the users listening preferences.

13.20 Variable High-Pass Audio Filter

Any DC offset from the input path is removed via IIR filters (typically <2 Hz roll-off, configurable). After reset the filters for both channels are enabled by default, but can be disabled by clearing ADC_HPF_EN and DAC_HPF_EN. The cut-off frequency of the filters can be programmed using ADC_AUDIO_HPF_CORNER and DAC_AUDIO_HPF_CORNER. Enabling the high pass filter is especially important if the ADC output is fed into the DAC.

Table 30: ADC/DAC digital high-pass filter specifications in audio mode

Sampling frequency (kHz)	Cut-off frequency (Hz) at ADC_AUDIO_HPF_CORNER and DAC_AUDIO_HPF_CORNER settings			
	00	01	10	11
8	0.3	0.7	1.3	2.7
11.025	0.4	0.9	1.8	3.7
12	0.5	1	2	4
16	0.7	1.3	2.7	5.3
22.05	0.9	1.8	3.7	7.3
24	1	2	4	8
32	1.3	2.7	5.3	10.7
44.1	1.8	3.7	7.3	14.7
48	2	4	8	16

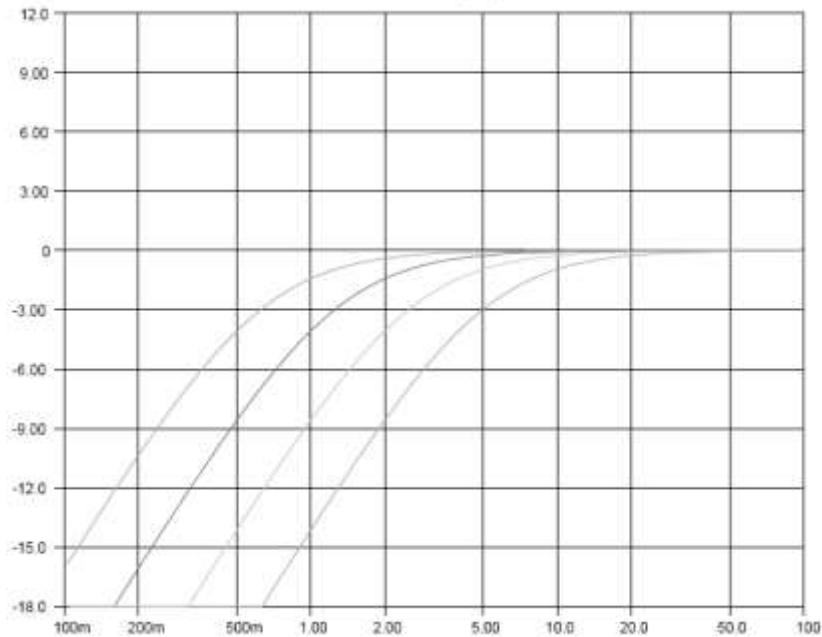

Figure 13: ADC and DAC DC blocking (Cut-off frequency setting '00' to '11', 16 kHz)

13.21 Variable High Pass Filter (Wind Noise Filtering)

To improve the quality of microphone recordings, the DA7212 provides a programmable high pass filter engine, enabled via `ADC_VOICE_EN` in the `ADC_FILTERS1` register. For the first filter, in music mode `ADC_VOICE_EN` must be set to 0 and the HPF corner frequency is set using `adc_audio_hpf_corner`.

In ADC voice mode, `ADC_VOICE_EN` must = 1 and `ADC_HPF_EN` must = 1 in which case the HPF corner frequency is set using `ADC_VOICE_HPF_CORNER`.

The low frequency roll off is configured over a wide range using the `ADC_VOICE_HPF_CORNER` control. This allows for flexible removal of wind and pop noise.

During playback, dedicated voiceband filtering can be enabled using `DAC_VOICE_EN`. In DAC voice mode, `DAC_VOICE_EN` must = 1 and `DAC_HPF_EN` must = 1 in which case the HPF corner frequency is set using `DAC_VOICE_HPF_CORNER`.

The low frequency roll off is configured over a wide range using the `DAC_VOICE_HPF_CORNER` control.

In voice mode, the wind noise high-pass filter cut-off frequency is determined by the settings of the `ADC_VOICE_HPF_CORNER` and the `DAC_VOICE_HPF_CORNER` register bits, These cut-off frequencies are not fixed, however, and vary with the sample rate being used. Table 31 shows the cut-off frequencies for all valid settings of `ADC_VOICE_HPF_CORNER` and `DAC_VOICE_HPF_CORNER`, at all sample rates of 16 kHz and below.

Table 31: Wind noise high-pass filter specifications

Cut-off frequency at <code>ADC_VOICE_HPF_CORNER</code> and <code>DAC_VOICE_HPF_CORNER</code> settings (voice filtering only, and with sample rate 16 kHz or lower)								
Fs [kHz]	000	001	010	011	100	101	110	111
8.0	2.5	25	50	100	150	200	300	400
11.025	3.4	34.5	69	138	207	276	413	551
12.0	3.75	37.5	75	150	225	300	450	600

16.0	5	50	100	200	300	400	600	800
------	---	----	-----	-----	-----	-----	-----	-----

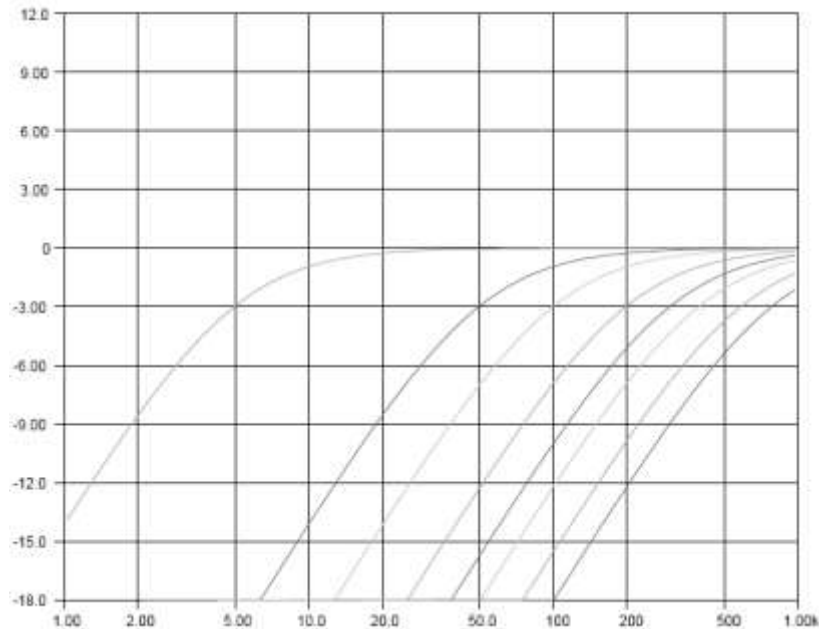

Figure 14: Wind noise high-pass filter (cut-off frequency setting '000' to '111', 16 kHz)

13.22 DAC 5-Band Equaliser

To enable user controllable listening preferences, the digital playback path includes a programmable 5 band equaliser that is enabled by control DAC_EQ_EN. A low pass filter, a three band-pass filters and a high pass filter with cut-off/centre frequencies at approximately 87 Hz, 132 Hz, 628 Hz, 2.6 kHz and 9.6 kHz (for FS=48 kHz) offer boosting or damping of each frequency band in 1.5 dB steps from 10.5 to +12 dB. The gains of each band can be individually configured using DAC_EQ_BAND1, DAC_EQ_BAND2, DAC_EQ_BAND3, DAC_EQ_BAND4, DAC_EQ_BAND5 controls.

The 5-band equaliser cannot be used at 88.2 and 96 kHz sampling rate. For frequency responses see [Table 32](#), and [Figure 15](#) to [Figure 19](#).

Table 32: DAC 5-band equaliser turnover/centre frequencies

Sampling frequency (kHz)	Centre/cut-off frequency of DAC 5-band equaliser (Hz)				
	Band 1 cut-off (Note 16)	Band 2 cut-off	Band 3 cut-off	Band 4 cut-off	Band 5 cut-off (Note 16)
8	21	85	563	1151	2909
11.025	29	117	776	2137	4009
12	31	128	845	2326	4364
16	41	90	441	2128	5840
22.05	56	124	607	2933	8048
24	61	135	664	3192	8759
32	58	95	418	1731	6374
44.1	80	132	577	2385	8784

Sampling frequency (kHz)	Centre/cut-off frequency of DAC 5-band equaliser (Hz)				
	Band 1 cut-off (Note 16)	Band 2 cut-off	Band 3 cut-off	Band 4 cut-off	Band 5 cut-off (Note 16)
48	87	143	628	2596	9560
88.2	N/A	N/A	N/A	N/A	N/A
96	N/A	N/A	N/A	N/A	N/A

Note 16 For equaliser bands 1 and 5, the cut-off frequency depends on the gain setting. The figures quoted in this table refer to the -1 dB point with the band gain set to -3 dB

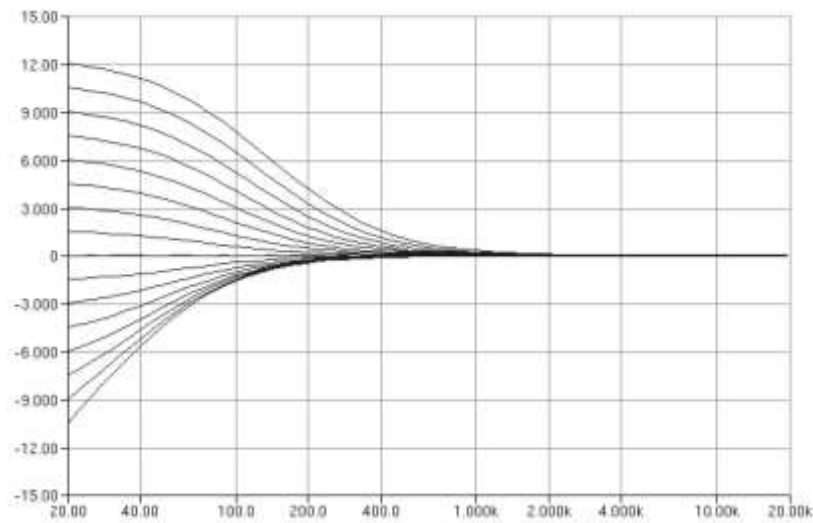

Figure 15: Equaliser filter band 1 frequency response at FS = 48 kHz

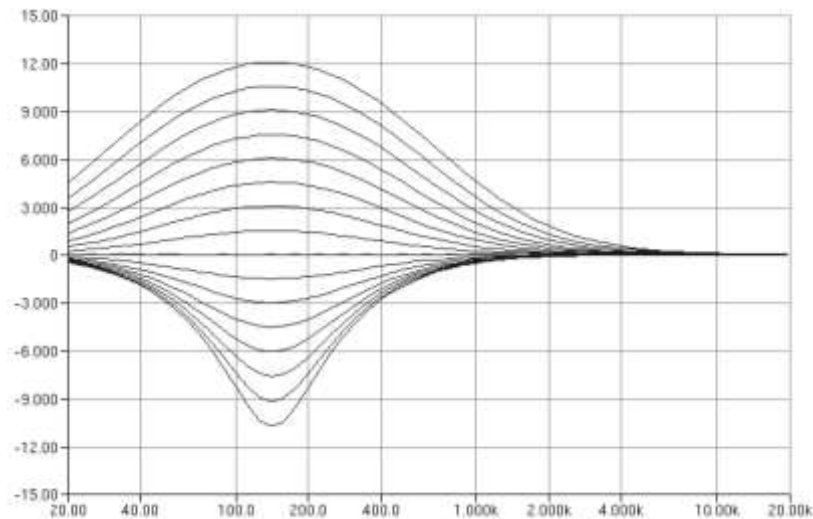

Figure 16: Equaliser filter band 2 frequency response at FS = 48 kHz

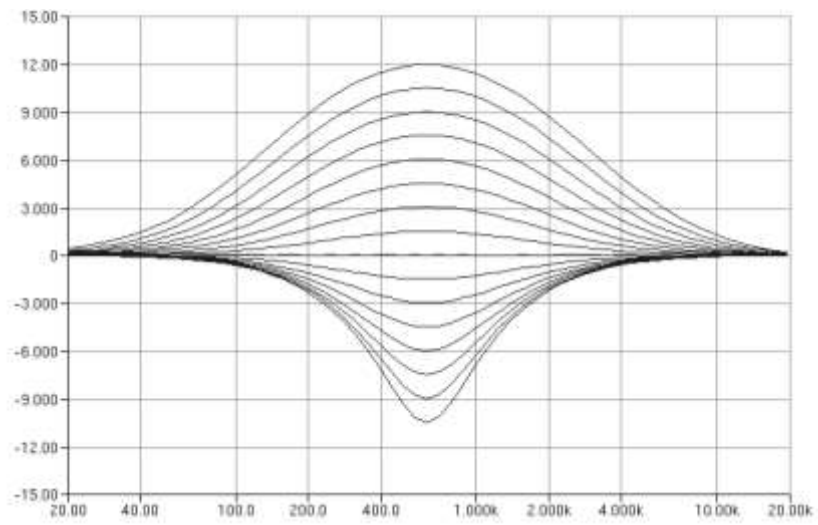

Figure 17: Equaliser filter band 3 frequency response at FS = 48 kHz

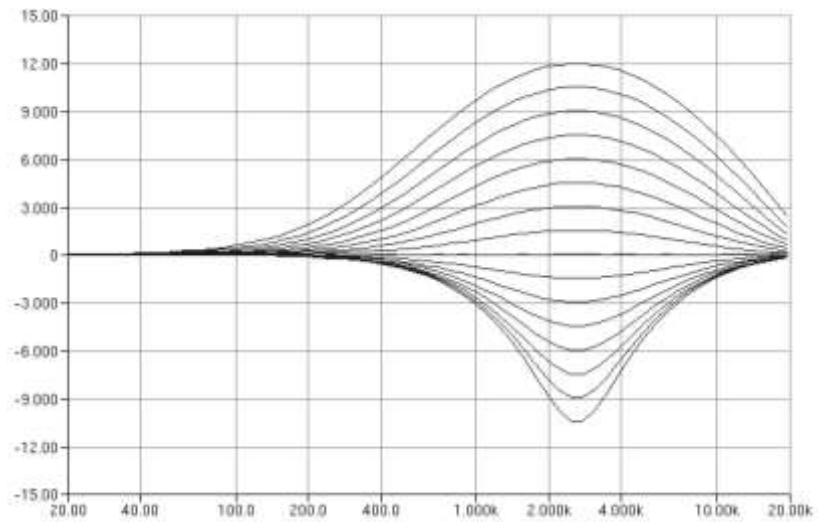
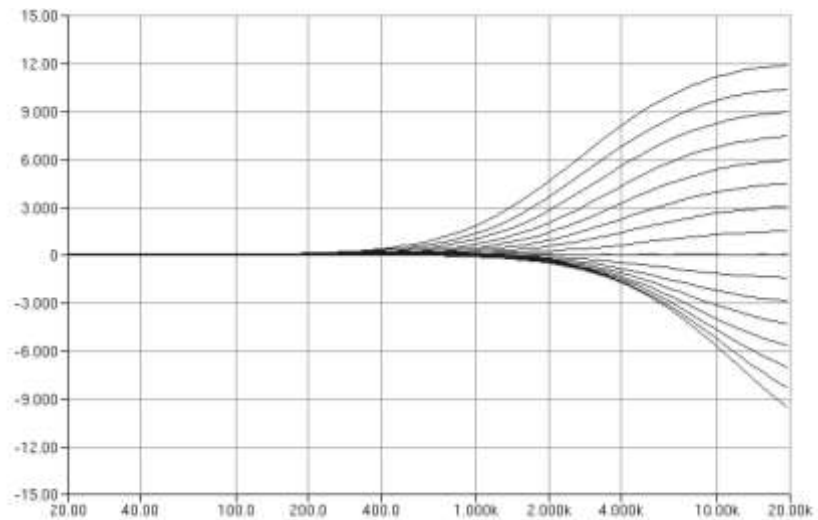

Figure 18: Equaliser filter band 4 frequency response at FS = 48 kHz



Ultra-Low Power Stereo Codec

Figure 19: Equaliser filter band 5 frequency response at FS = 48 kHz

13.23 Soft Mute

To improve the user's perception of audio reconfigurations, the DAC channel signals may be soft muted by asserting the control DAC_SOFTMUTE_EN. The soft mute function attenuates the digital input to the DAC, ramping the gain down in steps of 0.1875 dB from its current level to -77.25 dB, then completely muting the channel. When DAC_SOFTMUTE_EN is released, the attenuation is set to 77.25 dB, and then ramped up to the previous gain level. Both left and right channels of Soft Mute enabled output amplifiers are muted simultaneously. The ramping up and down rate is dependent on the audio sample rate and can be individually configured using control DAC_SOFTMUTE_RATE.

During active soft muting, the digital gain of the DAC will be different to the value programmed inside controls DAC_L_DIGITAL_GAIN_STATUS and DAC_R_DIGITAL_GAIN_STATUS.

13.24 Playback Noise-Gate

Noise-gate is an automatic gain control for DAC playback that reduces the noise heard during playback if no signal is present. It is enabled using the DAC_NG_EN control.

When the output signals on both channels are below a given threshold level, and they stay low for longer than a specified period, then playback noise-gate is activated. When the playback noise-gate activates, the gain on the active HP and Line amplifiers are ramped down to their lowest levels. This is equivalent to asserting the minimum-gain controls HP_L_AMP_MIN_GAIN_EN, HP_R_AMP_MIN_GAIN_EN and LINE_AMP_MIN_GAIN_EN.

The Noise-Gate Threshold Level can be specified in 6 dB steps from 90 dB to 48 dB. The Noise-Gate Threshold Time ranges from 256 samples to 2048 samples and is set using the control DAC_NG_SETUP_TIME.

When the averaged level of the two channels exceeds the release threshold configured in DAC_NG_OFF_THRESHOLD, the gain of the amplifiers is ramped up back to its original value. When the average level of the two channels is below the attack threshold configured in DAC_NG_ON_THRESHOLD for longer than the time specified in DAC_NG_SETUP_TIME, the gain is ramped down to its minimum value.

The attack and release rate can be configured via controls DAC_NG_RAMPDN_RATE and DAC_NG_RAMPUP_RATE. The Noise-gate release time is usually much faster than the attack time, to allow a proper playback as soon as a signal is present at the output amplifiers.

13.25 Clock Modes

The DA7212 requires a clock for operation of various circuits within the chip. There are four ways in which the main system clock may be generated:

- **PLL bypass mode:** If digital playback or record is required, the MCLK frequency should be set to one of 11.2896/12.288 MHz or 22.5792/24.576 MHz or 45.1584/49.152 MHz (Note 17). The PLL_INDIV register bit must then be programmed accordingly
- **Normal PLL mode:** Alternative frequency clock applied to MCLK pin (in the range of 2 to 50 MHz), where MCLK is synchronous with WCLK, or Master Mode is enabled
- **SRM PLL mode:** Clock applied to MCLK pin (in the range of 2 to 50 MHz) is asynchronous to WCLK
- **32 kHz mode:** Watch crystal frequency (32.768 kHz) clock applied to MCLK

Table 33: PLL clock modes

Mode	PLL bypassed	PLL enabled	PLL enabled SRM enabled	PLL enabled 32 kHz enabled
Master	Yes (Note 17)	Yes (Note 18)	No	Yes (Note 19)
Slave	Yes (Note 20)	Yes (Note 21)	Yes (Note 22)	No

Note 17 11.2896 MHz (or multiples) should be used as MCLK frequency for 11.025, 22.05, 44.1, 88.2 kHz sample rates and 12.288 MHz (or multiples) should be used for 8, 12, 16, 24, 32, 48, 96 kHz sample rates

Note 18 MCLK must be between 2 MHz and 50 MHz

Note 19 MCLK must be 32.768 kHz

Note 20 MCLK must be exactly 12.288 MHz or 11.2896 MHz or a multiple thereof and synchronous with BCLK and WCLK

Note 21 MCLK must be synchronous with BCLK and WCLK

Note 22 BCLK must be synchronous with WCLK. MCLK must be between 2 MHz and 50 MHz

With the default register settings, the clock input should be a square wave with CMOS logic levels (referenced to VDD_IO). A 'clock squarer circuit' can be enabled by asserting the PLL_MCLK_SQR_EN register bit. This clock squarer allows a sine wave or other a low amplitude clock (down to 300 mVpp) to be applied to the codec. The input is AC coupled on chip when using the clock squarer mode. If the MCLK input frequency drops below 1 MHz, the PLL_MCLK_STATUS bit is cleared, and the chip will automatically use its internal reference oscillator as a clock source.

13.26 PLL Bypass Mode

If an MCLK signal at 11.2896/12.288 MHz or 22.5792/24.576 MHz or 45.1584/49.152 MHz is available, the PLL is not required and should be disabled to save power. PLL bypass mode is activated by clearing the PLL enable register bit PLL_EN.

In this mode the PLL is bypassed and an audio frequency clock is applied to the MCLK pin of the codec. The required clock frequency depends on the sample rate at which the audio DACs and ADCs are operating. These clock frequencies are summarized in Table 34 for the range of DAC and ADC sample rates that can be configured using the SR register.

Table 34: Sample rate control register and corresponding system clock frequency

Sample rate, FS (kHz)	SR register	System clock frequency (MHz)
8	0001	12.288
11.025	0010	11.2896
12	0011	12.288
16	0101	12.288
22.05	0110	11.2896
24	0111	12.288
32	1001	12.288
44.1	1010	11.2896
48	1011	12.288
88.2	1110	11.2896
96	1111	12.288

If digital playback or record is required in bypass mode then the MCLK frequency should be set to 11.2896/12.288 MHz, or to 22.5792/24.576 MHz, or to 45.1584/49.152 MHz and PLL_INDIV should be programmed accordingly.

If no valid MCLK is detected, the output of the internal reference oscillator is used instead. However in this case only analogue bypass paths may be used.

13.26.1 Normal PLL Mode (DAI Master)

The DA7212 contains a Phase Locked Loop (PLL) that can be used to generate the required 11.2896 MHz or 12.288 MHz internal system clock when a frequency of between 2 and 50 MHz is applied to MCLK. This allows sharing of clocks between devices in an application, reducing total system cost. For example, the codec may operate from common 13 MHz or 19.2 MHz system clock frequency.

The PLL is enabled by asserting PLL_EN. Once the PLL is enabled and has achieved phase lock, PLL bypass mode is disabled, and the output of the PLL is used as the system clock.

The PLL input divider register (PLL_INDIV) is used to reduce the PLL reference frequency to the usable range of 2 to 5 MHz as shown in Table 35 reduces the PLL reference frequency according to the following equation:

$$F_{REF} = F_{MCLK} \div (2^{PLL_INDIV+1})$$

Table 35: PLL input divider

MCLK input frequency (MHz)	Input divider, ($\div N$)	PLL_INDIV register (0x27 [3:2])
2 – 10	$\div 2$	00
10 – 20	$\div 4$	01
20 – 40	$\div 8$	10
40 – 50	$\div 16$	11

The value of the PLL feedback divider is used to set the voltage controlled oscillator (VCO) frequency to 8 times the required system clock frequency (see Table 34).

$$F_{VCO} = F_{REF} \times \text{PLL feedback divider}$$

The value of the PLL feedback divider is an unsigned number in the range of 0 to 128. It consists of seven integer bits and 13 fractional bits split across three registers:

- PLL_INTEGER holds the seven integer bits
- PLL_FRAC_TOP holds the top bits (MSB) of the fractional part of the divisor
- PLL_FRAC_BOT holds the bottom bits (LSB) of the fractional part of the divisor

Ultra-Low Power Stereo Codec

13.26.2 Example Calculation of the Feedback Divider Setting

We will use as an example a codec operating with F_s (sample rate) = 48 kHz and a reference input clock frequency of 12.288 MHz. The required output frequency is 98.304 MHz.

The reference clock input = 12.288 MHz, which falls in the range 10-20 MHz so PLL_INDIV must be set to 0b01 (dividing the reference input frequency by 2 – see Table 35).

The formula for calculating the feedback divider is:

$$\text{Feedback divider (F)} = \text{VCO output frequency} * \text{input divider (PLL_INDIV)} / \text{reference input clock}$$

$$\text{Feedback divider} = (98.304 * 4) / 12.288 = 32$$

So

$$\text{PLL_FBDIV_INTEGER (holding the seven integer bits)} = 0x20$$

$$\text{PLL_FBDIV_FRAC_TOP (holding the top bits (MSB) of the fractional part of the divisor)} = 0x00$$

$$\text{PLL_FBDIV_FRAC_BOT (holding the bottom bits (LSB) of the fractional part of the divisor)} = 0x00$$

Table 36 shows example register settings that will configure the PLL when using a 13 MHz, 15 MHz or 19.2 MHz clock. Note that any MCLK input frequency between 2 and 50 MHz is supported. PLL_INDIV must be used to reduce the PLL reference frequency to the usable range of 2 to 10 MHz as shown in Table 36.

Table 36: Example PLL configurations

MCLK input frequency (MHz)	System clock frequency (MHz)	PLL_CTRL register (See Note 23)	PLL_FRAC_TOP register	PLL_FRAC_BOT register	PLL_INTEGER register
13	11.2896	0x84	0x19	0x45	0x1B
13	12.288	0x84	0x07	0xEA	0x1E
15	11.2896	0x84	0x02	0xB4	0x18
15	12.288	0x84	0x06	0xDC	0x1A
19.2	11.2896	0x84	0x1A	0x1C	0x12
19.2	12.288	0x84	0x0F	0x5C	0x14

Note 23 Any MCLK input frequency between 2 and 50 MHz is supported. PLL_INDIV must be used to reduce the PLL reference frequency to the usable range of 2 to 5 MHz.

13.27 SRM PLL Mode (DAI Slave)

SRM mode enables the PLL output clock to be synchronized to the incoming WCLK signal on the DAI. The SRM PLL mode is enabled by setting the PLL as for normal PLL mode and asserting register bit PLL_SRM_EN. Register bit SRM_LOCK indicates whether or not the SRM has achieved synchronisation with WCLK.

When using the digital audio interface in slave mode with the SRM enabled, removing and re-applying the DAI interface word clock WCLK may cause the PLL lock to be lost. To re-lock the PLL it is recommended that you disable the SRM (PLL_SRM_EN = 0), reset the PLL by re-writing to register PLL_INTEGER, and then re-enable the SRM (PLL_SRM_EN = 1) after the DAI WCLK has been reapplied.

When switching sample rates between 44.1 kHz and 48 kHz (or between the multiples of these sample rates), SRM must be disabled and then re-enabled using register bit PLL_SRM_EN.

13.28 32 kHz PLL Mode (DAI Master)

32 kHz mode enables the PLL output clock to be synchronized to a 32.768 kHz clock signal on the MCLK pin. 32 kHz PLL Mode is selected by enabling the PLL and asserting both PLL_SRM_EN and PLL_32K_MODE. Register bit PLL_SRM_LOCK indicates whether or not the SRM has achieved synchronisation with MCLK.

13.29 Operating with a 2 MHz to 5 MHz MCLK

When using the PLL with a 2 MHz-5 MHz MCLK, you must follow the procedure below to setup the PLL in the correct mode.

Setup PLL and clocking

Write F0 = 8b

Write F1 = 03

Write F0 = 00

When returning from this mode to a mode with an MCLK >5 MHz, you must follow the procedure below.

Write F0 = 8b

Write F1 = 01

Write F0 = 00

Setup PLL and clocking

13.30 Mixed Sample Rates

In DA7212 there is only one Sample Rate register and therefore, by default, this controls the sample rate of both the ADC and the DAC

Some applications require the ADC and the DAC to run at different sample rates. A special mode (24-48 Mode) is available by asserting 24_48_MODE at register address 0x84[0]. Asserting this bit sets the ADC to run at 24 kHz and the DAC to run at 48 kHz. In this mode all the functionality of the ADC and the DAC is available. The DAI will continue to run at 48 kHz, and every ADC sample will be repeated across two WCLK frames.

13.31 I2C Control Interface

The DA7212 is completely software-controlled from the host by registers. The DA7212 provides an I2C compliant serial control interface to access these registers. Data is shifted into or out of the DA7212 under the control of the host processor, which also provides the serial clock.

The 7-bit I2C slave address is 0x1A so that the 8-bit address for writing is 0x34 and for reading is 0x35.

The I2C clock is supplied by the SCL line and the bi-directional I2C data is carried by the SDA line. The I2C interface is open-drain supporting multiple devices on a single line. The bus lines have to be pulled HIGH by external pull-up resistors (1 kΩ to 20 kΩ range). The attached devices only drive the bus lines LOW by connecting them to ground. This means that two devices cannot conflict if they drive the bus simultaneously.

In standard/fast mode the highest frequency of the bus is 1 MHz. The exact frequency can be determined by the application and does not have any relation to the DA7212 internal clock signals. DA7212 will follow the host clock speed within the described limitations and does not initiate any clock arbitration or slow down.

In high-speed mode the maximum frequency of the bus can be increased up to 3.4 MHz. This mode is supported if the SCL line is driven with a push-pull stage from the host and if the host enables an external 3 mA pull-up at the SDA pin to decrease the rise time of the data. In this mode the SDA line on DA7212 is able to sink up to 12 mA. In all other respects the high speed mode behaves as the standard/fast mode. Communication on the I2C bus always takes place between two devices, one acting as the master and the other as the slave. The DA7212 will only operate as a SLAVE. The I2C interface has direct access to the whole register map of the DA7212 .

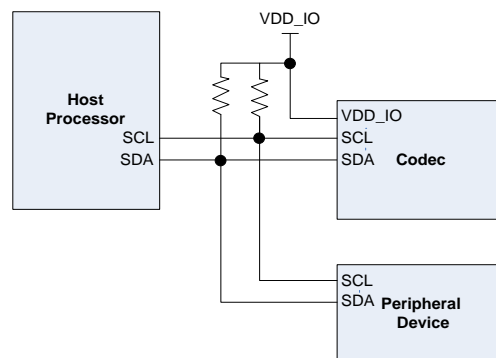

Figure 20: Schematic of the I2C control interface bus

13.32 Details of the I2C Control Interface Protocol

All data is transmitted across the I2C bus in groups of 8 bits. To send a bit the SDA line is driven to the intended state while the SDA is LOW (a LOW on SDA indicates a zero bit). Once the SDA has settled, the SCL line is brought HIGH and then LOW. This pulse on SCL clocks the SDA bit into the receiver's shift register.

A two byte serial protocol is used containing one byte for address and one byte for data. Data and address transfer is transmitted MSB first for both read and write operations. All transmission begins with the START condition from the master while the bus is in the IDLE state (the bus is free). It is initiated by a high to low transition on the SDA line while the SCL is in the high state (a STOP condition is indicated by a low to high transition on the SDA line while the SCL line is in the high state).

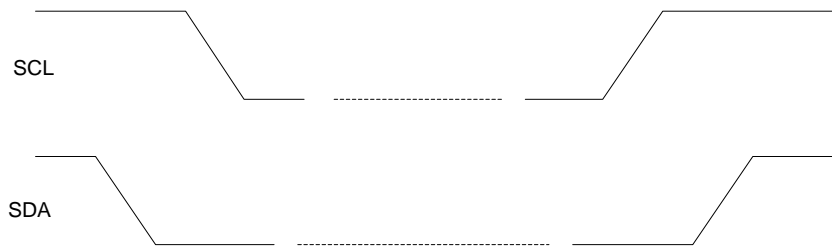

Figure 21 Timing of I2C START and STOP conditions

The I2C bus is monitored by DA7212 for a valid SLAVE address whenever the interface is enabled. It responds with an Acknowledge immediately when it receives its own slave address. The Acknowledge is done by pulling the SDA line low during the following clock cycle (white blocks marked with 'A' in Figure 22 to Figure 25).

The protocol for a register write from master to slave consists of a start condition, a slave address with read/write bit and the 8-bit register address followed by 8 bits of data terminated by a STOP condition (the DA7212 responds to all bytes with Acknowledge). This is illustrated in Figure 22.



Figure 22: I2C byte write (SDA signal)

When the host reads data from a register it first has to write-access DA7212 with the target register address and then read access DA7212 with a repeated START, or alternatively a second START condition. After receiving the data the host sends a Not Acknowledge (NAK) and terminates the transmission with a STOP condition:

Ultra-Low Power Stereo Codec

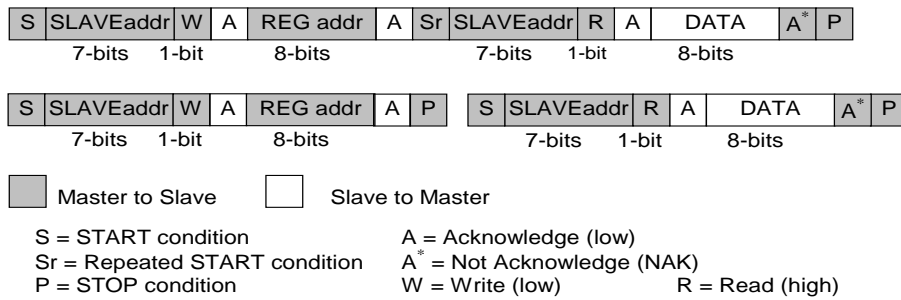

Figure 23: Examples of the I2C byte read (SDA line)

Consecutive (Page Mode) read-out mode (CIF_I2C_WRITE_MODE (0x1D [0]) = 0) is initiated from the master by sending an Acknowledge instead of Not Acknowledge (NAK) after receipt of the data word. The I2C control block then increments the address pointer to the next I2C address and sends the data to the master. This enables an unlimited read of data bytes until the master sends a NAK directly after the receipt of data, followed by a subsequent STOP condition. If a non-existent I2C address is read out, the DA7212 will return code zero.

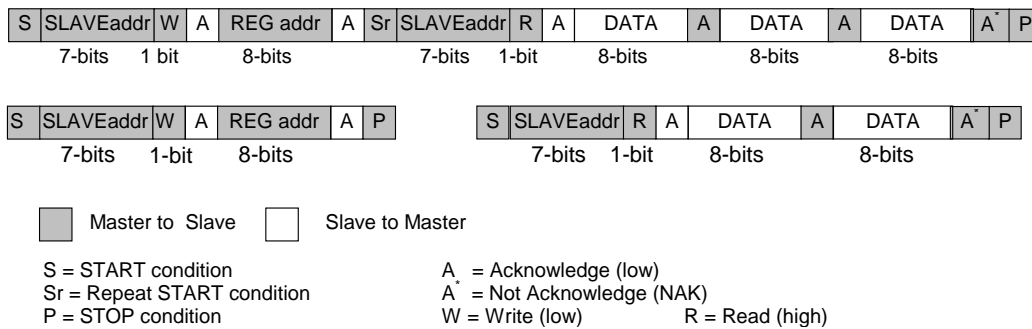

Figure 24: Examples of I2C page read (SDA line)

The slave address after the Repeated START condition must be the same as the previous slave address

Consecutive write-mode (CIF_I2C_WRITE_MODE (0x1D [0]) = 0) is supported if the master sends several data bytes following a slave register address. The I2C control block then increments the address pointer to the next I2C address, stores the received data and sends an acknowledge until the master sends the STOP condition.

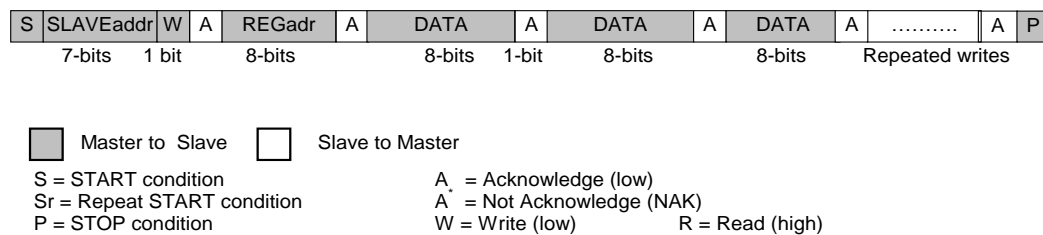

Figure 25: I2C page write (SDA line)

An alternative repeated-write mode that uses non-consecutive slave register addresses is available using the CIF_I2C_WRITE_MODE register. In this Repeat Mode (CIF_I2C_WRITE_MODE (0x1D [0]) = 1), the slave can be configured to support a host's repeated write operations into several non-consecutive registers. Data is stored at the previously received register address. If a new START or STOP condition occurs within a message, the bus returns to IDLE mode. This is illustrated in Figure 26.

Ultra-Low Power Stereo Codec

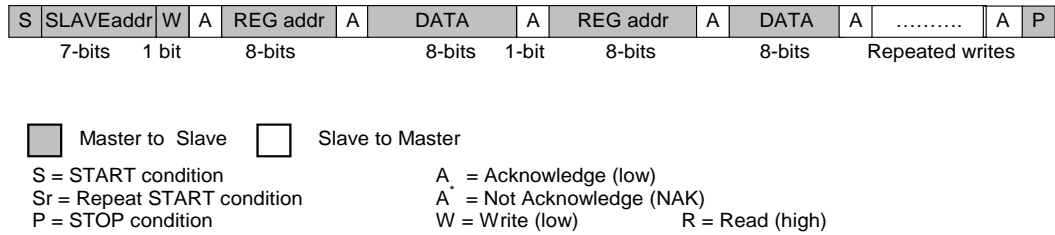

Figure 26: I2C repeated write (SDA line)

In Page Mode (CIF_I2C_WRITE_MODE = 0), both Page Mode reads and writes using auto-incremented addresses, and Repeat Mode reads and writes using non auto-incremented addresses, are supported. In Repeat Mode (CIF_I2C_WRITE_MODE = 1) however, only Repeat Mode reads and writes are supported.

13.33 Digital Audio Interface (DAI)

DA7212 provides one Digital audio interface (DAI) to input DAC data or to output ADC data. It is enabled by asserting DAI_EN. The DSP provides flexible routing options allowing each interface to be connected to different signal paths as desired in each application.

The DAI consists of a four-wire serial interface, with bit clock (BCLK), word clock (WCLK), data-in (DATIN) and data-out (DATOUT) pins. Both master and slave clock modes are supported by the DA7212 . Master mode is enabled setting register DAI_CLK_EN (0x28[7]) = 1. In master mode, the bit clock and word clock signals are outputs from the codec. In slave mode these are inputs to the codec.

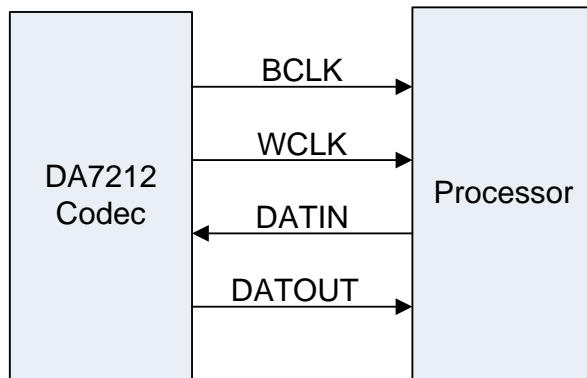

Figure 27: Master mode (DAI_CLK_EN = 1)

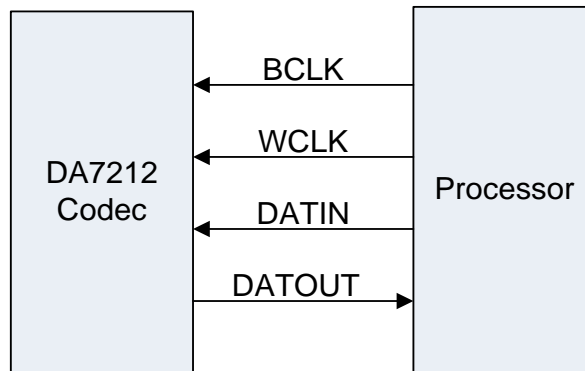

Figure 28: Slave mode (DAI_CLK_EN = 0)

The internal serialized DAI data is 24 bits wide. Serial data that is not 24 bits wide is either shortened or zero-filled at input to, or at output from, the DAI's internal 24-bit data width. The serial data word length can be configured to be 16, 20, 24 or 32 bits wide using the DAI_WORD_LENGTH register bits.

Four different data formats are supported by the digital audio interface. The data format is determined by the setting of the DAI_FORMAT register bits.

- I2S mode
- Left Justified mode
- Right Justified mode
- DSP mode

Time division multiplexing (TDM) is available in any of these modes to support the case where multiple devices are communicating simultaneously on the same bus. TDM is enabled by asserting the DAI_TDM_MODE_EN bit.

13.34 I2S Mode

In I2S mode (DAI_FORMAT = 0), the MSB of the left channel is valid on the second rising edge of the bit clock after the falling edge of the word clock. The MSB of the right channel is valid on the second rising edge of the bit clock after the rising edge of the word clock, and the MSB of the left channel is valid on the second rising edge of the bit clock after the falling edge of the word clock.

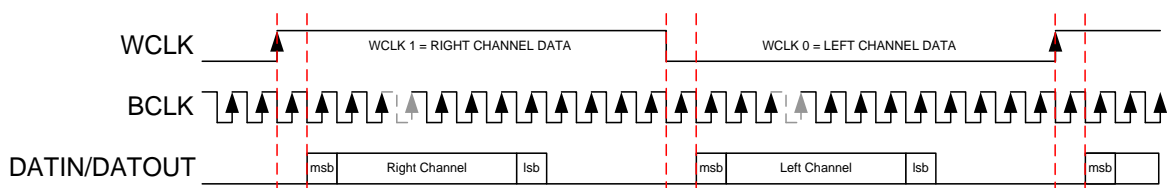

Figure 29: I2S mode

13.35 Left Justified Mode

In left-justified mode (DAI_FORMAT = 1), the MSB of the right channel is valid on the rising edge of the bit clock following the falling edge of the word clock. The MSB of the left channel is valid on the rising edge of the bit clock following the rising edge of the word clock.

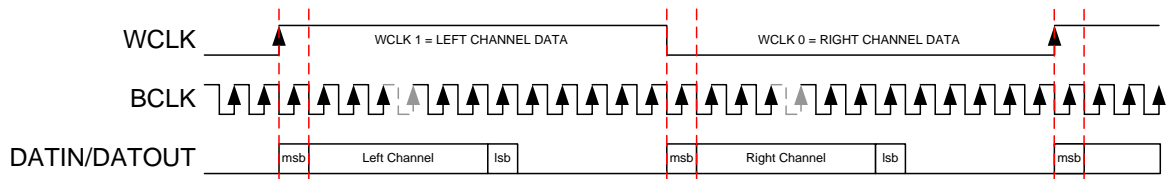

Figure 30: Left justified mode

13.36 Right Justified Mode

In right-justified mode (DAI_FORMAT = 2), the LSB of the left channel is valid on the rising edge of the bit clock preceding the falling edge of word clock. The LSB of the right channel is valid on the rising edge of the bit clock preceding the rising edge of the word clock.

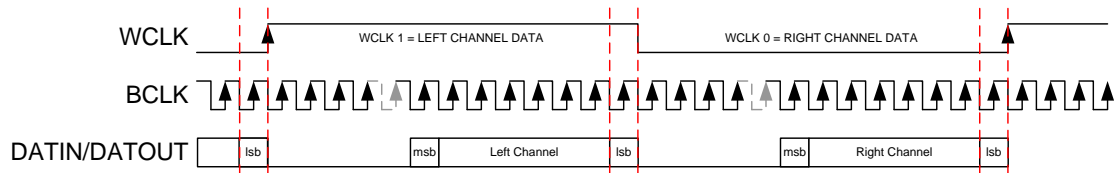

Figure 31: Right justified mode

13.37 DSP Mode

In DSP mode (DAI_FORMAT = 3), the rising edge of the word clock starts the data transfer with the left channel data first and immediately followed by the right channel data. Each data bit is valid on the falling edge of the bit clock.

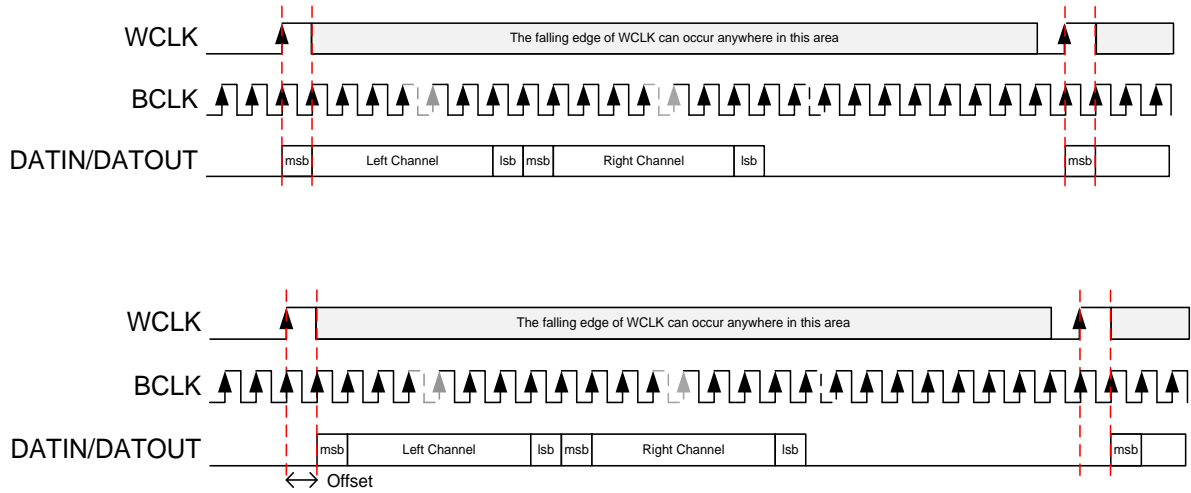

Figure 32: DSP mode

13.38 Time Division Multiplexing (TDM) Mode

Time division multiplexing (TDM) allows multiple devices to communicate on the same bus without conflicting. TDM mode (DAI_TDM_MODE_EN = 1) is an extension of the DSP and the left justified formats (see page 59).

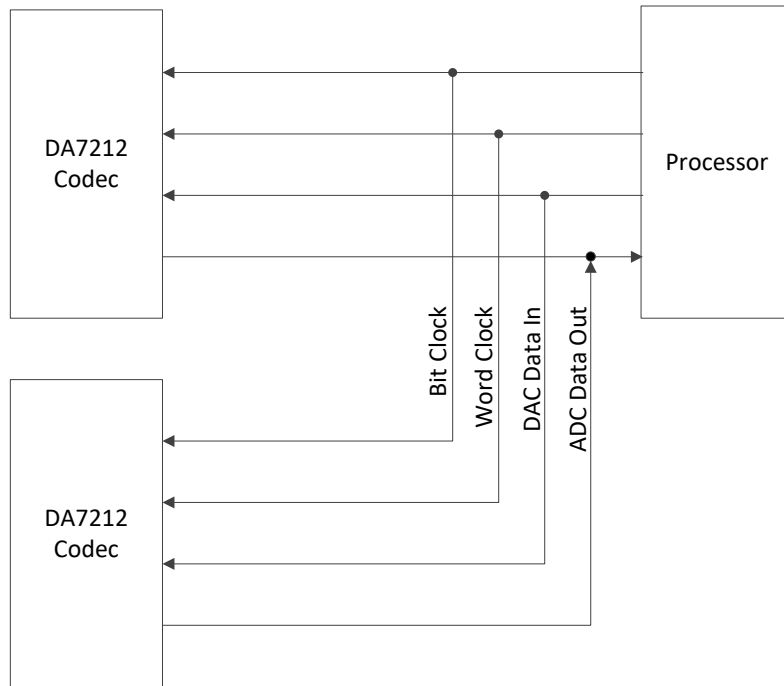

Figure 33: TDM example (slave mode)

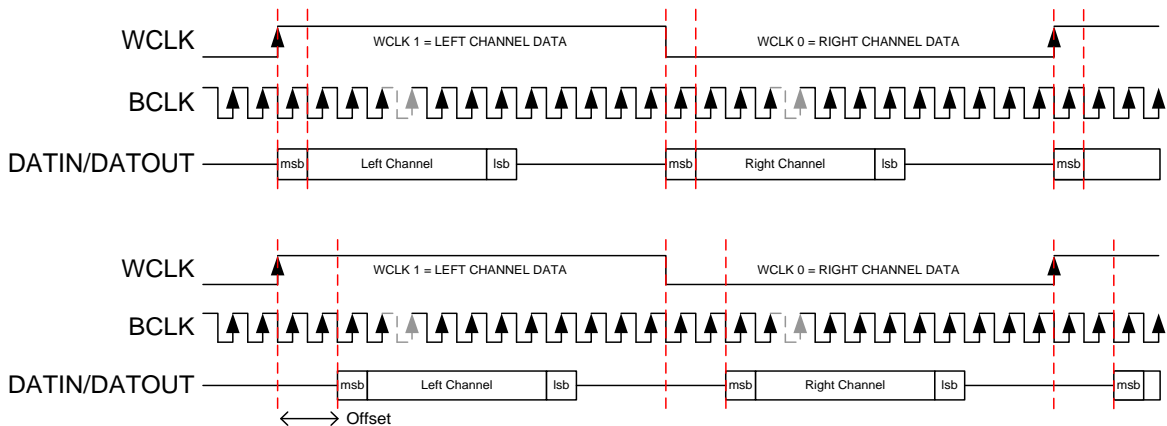

Figure 34: TDM mode (left justified mode)

A time offset is specified from the normal 'start of frame' condition using register bit DAI_OFFSET. Since a different offset may be defined for each device on the bus, they may both communicate without collisions.

In the left justified TDM example illustrated in Figure 34, the left channel data is valid DAI_OFFSET clock cycles after the rising edge of the word clock, and the right channel data is valid the same DAI_OFFSET number of clock cycles after the falling edge of the word clock.

Ultra-Low Power Stereo Codec

In DSP TDM mode (not illustrated), the left channel data is valid after the same DAI_OFFSET clock cycles from the rising edge of the word clock, but the right channel data is valid immediately after the left channel data.

The serial data pin must be tri-stated whenever the output is not valid.

Mono mode is supported in the TDM mode by asserting DAI_MONO_MODE_EN. If DAI_MONO_MODE_EN is asserted, only the data from the Digital Audio Interface left channel is transmitted.

13.38.1 Configuration of the Digital Audio Interface

The data format is configured using register DAI_FORMAT. The offset applied in TDM mode is configured using register DAI_OFFSET. The word length is configured using register DAI_WORD_LENGTH.

The digital audio interface is enabled using register DAI_EN and the frame length is configured using DAI_BCLKS_PER_WCLK.

When using the digital audio interface in slave mode (DAI_CLK_EN = 0), if the WCLK input is not from the same clock source as the MCLK input, then the SRM PLL mode must be enabled to maintain synchronization.

13.39 Pop-Free and Click-Free Startup Using the System Controllers

DA7212 has two system controllers that provide pop-free and click-free start-up under most conditions.

13.39.1 Level 1 System Controller (SCL1)

The Level 1 system controller (SCL1) is automatically activated whenever a sub-system's enable bit is asserted. SCL1 ensures that the desired component parts are sequenced in the correct order to provide click-free and pop-free start-up.

The following example using the left DAC illustrates SCL1 in operation.

1. When the left DAC is enabled by assertion of the DAC_L_EN register bit (register 0x69[7])
 - a. SCL1 first activates the DAC clocks
 - b. SCL1 then activates the DSP logic
 - c. Next, SCL1 activates the analogue DAC
 - d. Finally, SCL1 ramps up the digital gain

In this way, SCL1 helps ensure that the DAC_L start-up is free of pops and clicks.

Note, if any dependent functions for a sub-system's activation have not been enabled, SCL1 will not automatically enable them. This allows you greater control over the sequencing of the sub-system, but it also means that any sub-system can potentially be brought up in such a way that audible artefacts such as pops and clicks are introduced.

Ultra-Low Power Stereo Codec

13.39.2 Level 2 System Controller (SCL2)

Level 2 system controller (SCL2) is a higher level controller that provides one-touch activation of standard operating modes. Input or output sub-systems can be activated either singly or in combination. All selected sub-systems will start up in the correct order and without pops or clicks when SCL2 is activated.

First, the desired input sub-systems must be selected by asserting the relevant fields (bits 1 to 7) of the SYSTEM_MODES_INPUT (0x50) register. Similarly, the desired output sub-systems must be selected by asserting the relevant fields (bits 1 to 7) of the SYSTEM_MODES_OUTPUT (0x51) register.

Once the desired sub-systems have been selected, the SCL2 controller is activated by writing '1' to the MODE_SUBMIT register field in either the SYSTEM_MODES_INPUT (0x50) or the SYSTEM_MODES_OUTPUT (0x51) register. It does not matter which of the two MODE_SUBMIT fields is asserted. Both work in the same way, and each will start up both the input and the output sub-systems.

When SCL2 is activated by asserting MODE_SUBMIT, all of the register-writes that are required by the selected sub-systems are performed automatically. Each sub-system is brought up in the correct order to avoid pops and clicks, and within each sub-system, the component parts are brought up in the correct pop-free and click-free sequence.

The MODE_SUBMIT field used to start SCL2 is self-clearing, and is automatically reset to '0' once SCL2 has started.

SCL1 and SCL2 activity can be monitored using the SCL1_BUSY and SCL2_BUSY bits on the SYSTEM_STATUS (0xE0) register.

If the DA7212 device is changed from one playback mode to another, or if it is changed from one record mode to another, the initial mode is closed down first before the second mode is activated. This happens automatically.

13.40 Power Supply – Standby Mode

DA7212 has an ultra-low power standby mode that can be enabled to save power when the device is not in use. Standby mode is controlled using the SYSTEM_ACTIVE register.

13.40.1 Entering Standby Mode

Standby mode is activated by writing a '0' to the SYSTEM_ACTIVE register bit. This SYSTEM_ACTIVE register cannot be read when in standby mode because the act of reading the bit causes it to be asserted, which causes the standby mode to be exited.

When entering standby mode, it is important that all audio paths are shut down first because the shut down is abrupt and audio artefacts such as pops and click may be heard. No audio functions are possible during standby mode, as the reference oscillator and the reference voltages are both shut down.

When using the line/speaker output the amplifier **must** be disabled prior to entering standby mode.

13.40.2 Exiting Standby Mode

Standby mode can be exited by writing a '1' to the SYSTEM_ACTIVE register bit.

Any read or write access to the DA7212 will also cause the SYSTEM_ACTIVE bit to be asserted, but note that the first read or write access may fail because of the time taken to restart the reference oscillator. It is recommended that standby mode is exited by writing to the SYSTEM_ACTIVE register rather than relying on the automatic assertion of the register by a read or write access.

Read or write accesses to I2C slave addresses other than those used by the DA7212 will not cause standby mode to be exited.

14 Register definitions

14.1 Register map

Addr	Function	7	6	5	4	3	2	1	0
Status registers									
0x02	STATUS1	Reserved	Reserved	Reserved	Reserved	Reserved	Reserved	Reserved	Reserved
0x03	PLL_STATUS	Reserved	Reserved	Reserved	Reserved	PLL_BYPASS_ACTIVE	PLL_MCLK_STATUS	PLL_SRM_LOCK	PLL_LOCK
0x04	AUX_L_GAIN_STATUS	Reserved	Reserved	AUX_L_AMP_GAIN_STATUS					
0x05	AUX_R_GAIN_STATUS	Reserved	Reserved	AUX_R_AMP_GAIN_STATUS					
0x06	MIC_1_GAIN_STATUS	Reserved	Reserved	Reserved	Reserved	Reserved	MIC_1_AMP_GAIN_STATUS		
0x07	MIC_2_GAIN_STATUS	Reserved	Reserved	Reserved	Reserved	Reserved	MIC_2_AMP_GAIN_STATUS		
0x08	MIXIN_L_GAIN_STATUS	Reserved	Reserved	Reserved	Reserved	MIXIN_L_AMP_GAIN_STATUS			
0x09	MIXIN_R_GAIN_STATUS	Reserved	Reserved	Reserved	Reserved	MIXIN_R_AMP_GAIN_STATUS			
0x0A	ADC_L_GAIN_STATUS	Reserved	ADC_L_DIGITAL_GAIN_STATUS						
0x0B	ADC_R_GAIN_STATUS	Reserved	ADC_R_DIGITAL_GAIN_STATUS						
0x0C	DAC_L_GAIN_STATUS	Reserved	DAC_L_DIGITAL_GAIN_STATUS						
0x0D	DAC_R_GAIN_STATUS	Reserved	DAC_R_DIGITAL_GAIN_STATUS						
0x0E	HP_L_GAIN_STATUS	Reserved	Reserved	HP_L_AMP_GAIN_STATUS					
0x0F	HP_R_GAIN_STATUS	Reserved	Reserved	HP_R_AMP_GAIN_STATUS					
0x10	LINE_GAIN_STATUS	Reserved	Reserved	LINE_AMP_GAIN_STATUS					
System initialisation registers									
0x1D	CIF_CTRL	CIF_REG_SOFT_RESET	Reserved	Reserved	Reserved	Reserved	Reserved	Reserved	CIF_I2C_WRITE_MODE
0x21	DIG_ROUTING_DAI	Reserved	Reserved	DAI_R_SRC			Reserved	Reserved	DAI_L_SRC
0x22	SR	Reserved	Reserved	Reserved	Reserved	SR			
0x23	REFERENCES	Reserved	Reserved	VMID_FAST_DISCHARGE	VMID_FAST_CHARGE	BIAS_EN	Reserved	Reserved	Reserved
0x24	PLL_FRAC_TOP	Reserved	Reserved	Reserved	PLL_FBDIV_FRAC_TOP				

Ultra-Low Power Stereo Codec

Addr	Function	7	6	5	4	3	2	1	0
0x25	PLL_FRAC_BOT	PLL_FBDIV_FRAC_BOT							
0x26	PLL_INTEGER	Reserved	PLL_FBDIV_INTEGER						
0x27	PLL_CTRL	PLL_EN	PLL_SRM_EN	PLL_32K_MODE	PLL_MCLK_SQR_EN	PLL_INDIV		Reserved	Reserved
0x28	DAI_CLK_MODE	DAI_CLK_EN	Reserved	Reserved	Reserved	DAI_WCLK_POL	DAI_CLK_POL	DAI_BCLKS_PER_WCLK	
0x29	DAI_CTRL	DAI_EN	DAI_OE	DAI_TDM_MODE_EN	DAI_MONO_MODE_EN	DAI_WORD_LENGTH		DAI_FORMAT	
0x2A	DIG_ROUTING_DAC	DAC_R_MONO	Reserved	DAC_R_SRC		DAC_L_MONO	Reserved	DAC_L_SRC	
0x2B	ALC_CTRL1	ALC_R_EN	Reserved	ALC_CALIB_OVERFLOW	ALC_AUTO_CALIB_EN	ALC_L_EN	ALC_CALIB_MODE	ALC_SYNC_MODE	ALC_OFFSET_EN
Input gain / select filter registers									
0x30	AUX_L_GAIN	Reserved	Reserved	AUX_L_AMP_GAIN					
0x31	AUX_R_GAIN	Reserved	Reserved	AUX_R_AMP_GAIN					
0x32	MIXIN_L_SELECT	DMIC_L_EN	Reserved	Reserved		MIXIN_L_SEL	MIC2_SEL	MIC1_SEL	AUX_L_SEL
0x33	MIXIN_R_SELECT	DMIC_R_EN	Reserved	Reserved		MIXIN_L_SEL	MIC1_SEL	MIC2_SEL	AUX_R_SEL
0x34	MIXIN_L_GAIN	Reserved	Reserved	Reserved	Reserved	MIXIN_L_AMP_GAIN			
0x35	MIXIN_R_GAIN	Reserved	Reserved	Reserved	Reserved	MIXIN_R_AMP_GAIN			
0x36	ADC_L_GAIN	Reserved	ADC_L_DIGITAL_GAIN						
0x37	ADC_R_GAIN	Reserved	ADC_R_DIGITAL_GAIN						
0x38	ADC_FILTERS1	ADC_HPF_EN	Reserved	ADC_AUDIO_HPF_CORNER		ADC_VOICE_EN	ADC_VOICE_HPF_CORNER		
0x39	MIC_1_GAIN	Reserved	Reserved	Reserved	Reserved	Reserved	MIC_1_AMP_GAIN		
0x3A	MIC_2_GAIN	Reserved	Reserved	Reserved	Reserved	Reserved	MIC_2_AMP_GAIN		
Output gain / Select filter registers									
0x40	DAC_FILTERS5	DAC_SOFTMUTE_EN	DAC_SOFTMUTE_RATE			Reserved	Reserved	Reserved	Reserved
0x41	DAC_FILTERS2	DAC_EQ_BAND2				DAC_EQ_BAND1			
0x42	DAC_FILTERS3	DAC_EQ_BAND4				DAC_EQ_BAND3			
0x43	DAC_FILTERS4	DAC_EQ_EN	Reserved	Reserved	Reserved	DAC_EQ_BAND5			
0x44	DAC_FILTERS1	DAC_HPF_EN	Reserved	DAC_AUDIO_HPF_CORNER		DAC_VOICE_EN	DAC_VOICE_HPF_CORNER		

Ultra-Low Power Stereo Codec

Addr	Function	7	6	5	4	3	2	1	0
0x45	DAC_L_GAIN	Reserved	DAC_L_DIGITAL_GAIN						
0x46	DAC_R_GAIN	Reserved	DAC_R_DIGITAL_GAIN						
0x47	CP_CTRL	CP_EN	CP_SMALL_SWIT CH_FREQ_EN	CP_MCHANGE		CP_MOD		CP_ANALOGUE_LVL	
0x48	HP_L_GAIN	Reserved	Reserved	HP_L_AMP_GAIN					
0x49	HP_R_GAIN	Reserved	Reserved	HP_R_AMP_GAIN					
0x4A	LINE_GAIN	Reserved	Reserved	LINE_AMP_GAIN					
0x4B	MIXOUT_L_SELECT	Reserved	MIXIN_R_INV	MIXIN_L_INV	AUX_L_INV	DAC_L	MIXIN_R	MIXIN_L	AUX_L
0x4C	MIXOUT_R_SELECT	Reserved	MIXIN_L_INV	MIXIN_R_INV	AUX_R_INV	DAC_R	MIXIN_L	MIXIN_R	AUX_R
System controller registers (1)									
0x50	SYSTEM_MODES_INPU T	ADC_R	ADC_L	MIXIN_R	MIXIN_L	MIC_2	MIC_1	Reserved	MODE_SUBMIT
0x51	SYSTEM_MODES_OUTP UT	DAC_R	DAC_L	HP_R	HP_L	LINE	AUX_R	AUX_L	MODE_SUBMIT
Control registers (2)									
0x60	AUX_L_CTRL	AUX_L_AMP_EN	AUX_L_AMP_MUT E_EN	AUX_L_AMP_RAMP _EN	AUX_L_AMP_ZC_EN	AUX_L_AMP_ZC_SEL		Reserved	Reserved
0x61	AUX_R_CTRL	AUX_R_AMP_EN	AUX_R_AMP_MUT E_EN	AUX_R_AMP_RAMP _EN	AUX_R_AMP_ZC_EN	AUX_R_AMP_ZC_SEL		Reserved	Reserved
0x62	MICBIAS_CTRL	MICBIAS2_EN	Reserved	MICBIAS2_LEVEL		MICBIAS1_EN	Reserved	MICBIAS1_LVL	
0x63	MIC_1_CTRL	MIC_1_AMP_EN	MIC_1_AMP_MUT E_EN	Reserved	Reserved	MIC_1_AMP_IN_SEL		Reserved	Reserved
0x64	MIC_2_CTRL	MIC_2_AMP_EN	MIC_2_AMP_MUT E_EN	Reserved	Reserved	MIC_2_AMP_IN_SEL		Reserved	Reserved
0x65	MIXIN_L_CTRL	MIXIN_L_AMP_E N	MIXIN_L_AMP_MU TE_EN	MIXIN_L_AMP_RAM P_EN	MIXIN_L_AMP_ZC_E N	MIXIN_L_MIX_EN	Reserved	Reserved	Reserved
0x66	MIXIN_R_CTRL	MIXIN_R_AMP_E N	MIXIN_R_AMP_MU TE_EN	MIXIN_R_AMP_RAM P_EN	MIXIN_R_AMP_ZC_E N	MIXIN_R_MIX_EN	Reserved	Reserved	Reserved
0x67	ADC_L_CTRL	ADC_L_EN	ADC_L_MUTE_EN	ADC_L_RAMP_EN	Reserved	Reserved	Reserved	Reserved	Reserved
0x68	ADC_R_CTRL	ADC_R_EN	ADC_R_MUTE_EN	ADC_R_RAMP_EN	Reserved	Reserved	Reserved	Reserved	Reserved

Ultra-Low Power Stereo Codec

Addr	Function	7	6	5	4	3	2	1	0
0x69	DAC_L_CTRL	DAC_L_EN	DAC_L_MUTE_EN	DAC_L_RAMP_EN	Reserved	Reserved	Reserved	Reserved	Reserved
0x6A	DAC_R_CTRL	DAC_R_EN	DAC_R_MUTE_EN	DAC_R_RAMP_EN	Reserved	Reserved	Reserved	Reserved	Reserved
0x6B	HP_L_CTRL	HP_L_AMP_EN	HP_L_AMP_MUTE_EN	HP_L_AMP_RAMP_EN	HP_L_AMP_ZC_EN	HP_L_AMP_OE	HP_L_AMP_MIN_GAIN_EN	Reserved	Reserved
0x6C	HP_R_CTRL	HP_R_AMP_EN	HP_R_AMP_MUTE_EN	HP_R_AMP_RAMP_EN	HP_R_AMP_ZC_EN	HP_R_AMP_OE	HP_R_AMP_MIN_GAIN_EN	Reserved	Reserved
0x6D	LINE_CTRL	LINE_AMP_EN	LINE_AMP_MUTE_EN	LINE_AMP_RAMP_EN	Reserved	LINE_AMP_OE	LINE_AMP_MIN_GAIN_EN	Reserved	Reserved
0x6E	MIXOUT_L_CTRL	MIXOUT_L_AMP_EN	Reserved	Reserved	MIXOUT_L_SOFTMIX_EN	MIXOUT_L_MIX_EN	Reserved	Reserved	Reserved
0x6F	MIXOUT_R_CTRL	MIXOUT_R_AMP_EN	Reserved	Reserved	MIXOUT_R_SOFTMIX_EN	MIXOUT_R_MIX_EN	Reserved	Reserved	Reserved
Mixed sample mode register									
0x84	MIXED_SAMPLE_MODE	Reserved	Reserved	Reserved	Reserved	Reserved	Reserved	Reserved	24_48_MODE
Configuration registers									
0x90	LDO_CTRL	LDO_EN	Reserved	LDO_LEVEL_SELECT		Reserved	Reserved	Reserved	Reserved
0x92	GAIN_RAMP_CTRL	Reserved	Reserved	Reserved	Reserved	Reserved	Reserved	GAIN_RAMP_RATE	
0x93	MIC_CONFIG	Reserved	Reserved	Reserved		Reserved	DMIC_CLK_RATE	DMIC_SAMPLEPHASE	DMIC_DATA_SEL
0x94	PC_COUNT	Reserved	Reserved	Reserved	Reserved	Reserved	Reserved	PC_RESYNC_AUTO	PC_FREERUN
0x95	CP_VOL_THRESHOLD1	Reserved	Reserved	CP_THRESH_VDD2					
0x96	CP_DELAY	CP_ON_OFF		CP_TAU_DELAY			CP_FCONTROL		
0x97	CP_DETECTOR	Reserved	Reserved	Reserved	Reserved	Reserved	Reserved	CPDET_DROP	
0x98	DAI_OFFSET	DAI_OFFSET							
0x99	DIG_CTRL	DAC_R_INV	Reserved	Reserved	Reserved	DAC_L_INV	Reserved	Reserved	Reserved
0x9A	ALC_CTRL2	ALC_RELEASE				ALC_ATTACK			
0x9B	ALC_CTRL3	ALC_INTEG_RELEASE		ALC_INTEG_ATTACK		ALC_HOLD			
0x9C	ALC_NOISE	Reserved	Reserved	ALC_NOISE					
0x9D	ALC_TARGET_MIN	Reserved	Reserved	ALC_THRESHOLD_MIN					
0x9E	ALC_THRESHOLD_MAX	Reserved	Reserved	ALC_THRESHOLD_MAX					

Ultra-Low Power Stereo Codec

Addr	Function	7	6	5	4	3	2	1	0
0x9F	ALC_GAIN_LIMITS	ALC_GAIN_MAX				ALC_ATTEN_MAX			
0xA0	ALC_ANA_GAIN_LIMITS	Reserved	ALC_ANA_GAIN_MAX			Reserved	ALC_ANA_GAIN_MIN		
0xA1	ALC_ANTICLIP_CTRL	ALC_ANTICLIP_EN	Reserved	Reserved	Reserved	Reserved	Reserved	Reserved	Reserved
0xA2	ALC_ANTICLIP_LEVEL	Reserved	ALC_ANTICLIP_LEVEL						
0xA3	ALC_OFFSET_AUTO_M_L	Reserved	Reserved	Reserved	Reserved	Reserved	Reserved	Reserved	Reserved
0xA4	ALC_OFFSET_AUTO_U_L	Reserved	Reserved	Reserved	Reserved	Reserved	Reserved	Reserved	Reserved
0xA6	ALC_OFFSET_MAN_M_L	Reserved	Reserved	Reserved	Reserved	Reserved	Reserved	Reserved	Reserved
0xA7	ALC_OFFSET_MAN_U_L	Reserved	Reserved	Reserved	Reserved	Reserved	Reserved	Reserved	Reserved
0xA8	ALC_OFFSET_AUTO_M_R	Reserved	Reserved	Reserved	Reserved	Reserved	Reserved	Reserved	Reserved
0xA9	ALC_OFFSET_AUTO_U_R	Reserved	Reserved	Reserved	Reserved	Reserved	Reserved	Reserved	Reserved
0xAB	ALC_OFFSET_MAN_M_R	Reserved	Reserved	Reserved	Reserved	Reserved	Reserved	Reserved	Reserved
0xAC	ALC_OFFSET_MAN_U_R	Reserved	Reserved	Reserved	Reserved	Reserved	Reserved	Reserved	Reserved
0xAD	ALC_CIC_OP_LVL_CTRL	Reserved	Reserved	Reserved	Reserved	Reserved	Reserved	Reserved	Reserved
0xAE	ALC_CIC_OP_LVL_DATA	Reserved	Reserved	Reserved	Reserved	Reserved	Reserved	Reserved	Reserved
0xAF	DAC_NG_SETUP_TIME	Reserved	Reserved	Reserved	Reserved	DAC_NG_RAMPDN_RATE	DAC_NG_RAMPUP_RATE	DAC_NG_SETUP_TIME	
0xB0	DAC_NG_OFF_THRESHOLD	Reserved	Reserved	Reserved	Reserved	Reserved	DAC_NG_OFF_THRESHOLD		
0xB1	DAC_NG_ON_THRESHOLD	Reserved	Reserved	Reserved	Reserved	Reserved	DAC_NG_ON_THRESHOLD		
0xB2	DAC_NG_CTRL	DAC_NG_EN	Reserved	Reserved	Reserved	Reserved	Reserved	Reserved	Reserved
Tone generation & beep registers									
0xB4	TONE_GEN_CFG1	START_STOPN	Reserved	Reserved	DTMF_EN	DTMF_REG			
0xB5	TONE_GEN_CFG2	GAIN				Reserved	Reserved	SWG_SEL	
0xB6	TONE_GEN_CYCLES	Reserved	Reserved	Reserved	Reserved	Reserved	BEEP_CYCLES		

Ultra-Low Power Stereo Codec

Addr	Function	7	6	5	4	3	2	1	0
0xB7	TONE_GEN_FREQ1_L	FREQ1_L							
0xB8	TONE_GEN_FREQ1_U	FREQ1_U							
0xB9	TONE_GEN_FREQ2_L	FREQ2_L							
0xBA	TONE_GEN_FREQ2_U	FREQ2_U							
0xBB	TONE_GEN_ON_PER	Reserved	Reserved	BEEP_ON_PER					
0xBC	TONE_GEN_OFF_PER	Reserved	Reserved	BEEP_OFF_PER					
System controller registers (2)									
0xE0	SYSTEM_STATUS	Reserved	Reserved	Reserved	Reserved	Reserved	Reserved	SC2_BUSY	SC1_BUSY
0xFD	SYSTEM_ACTIVE	Reserved	Reserved	Reserved	Reserved	Reserved	Reserved	Reserved	SYSTEM_ACTIVE

14.2 Status Registers

Register address	Bit	Type	Label	Default	Description
0x02 STATUS1	7:0	R	(reserved)	00000000	

Register address	Bit	Type	Label	Default	Description
0x03 PLL_STATU S	7:4	R	(reserved)	0000	
	3	R	PLL_BYPASS_A CTIVE	0	Indicates whether the PLL is in bypass mode 0 = not in bypass mode 1 = bypass mode
	2	R	PLL_MCLK_STA TUS	0	Indicates if the frequency on MCLK is greater than 1 MHz 0 = MCLK frequency 1 MHz or less 1 = MCLK frequency greater than 1 MHz
	1	R	PLL_SRM_LOC K	0	Asserted if the SRM is locked to the reference signal 0 = SRM not locked to reference signal 1 = SRM locked to reference signal
	0	R	PLL_LOCK	0	Asserted if the PLL is locked to the reference clock 0 = PLL not locked to reference clock 1 = PLL locked to reference clock

Register address	Bit	Type	Label	Default	Description
0x04 AUX_L_GAI N_STATUS	7:6	R	(reserved)	00	
	5:0	R	AUX_L_AMP_G AIN_STATUS	000000	Actual AUX_L amplifier gain 000000 to 010001 = -54 dB 010010 = -52.5 dB 010011 = -51 dB continuing in +1.5 dB steps to 111110 = 13.5 dB 111111 = 15 dB

Ultra-Low Power Stereo Codec

Register address	Bit	Type	Label	Default	Description
0x05 AUX_R_GAIN_STATUS	7:6	R	(reserved)	00	
	5:0	R	AUX_R_AMP_GAIN_STATUS	000000	Actual AUX_R amplifier gain 000000 to 010001 = -54 dB 010010 = -52.5 dB 010011 = -51 dB continuing in +1.5 dB steps to 111110 = 13.5 dB 111111 = 15 dB

Register address	Bit	Type	Label	Default	Description
0x06 MIC_1_GAIN_STATUS	7:3	R	(reserved)	00000	
	2:0	R	MIC_1_AMP_GAIN_STATUS	001	Actual MIC_1 amplifier gain 000 = -6 dB 001 = 0 dB 010 = 6 dB and continuing in +6 dB steps to 111 = 36 dB

Register address	Bit	Type	Label	Default	Description
0x07 MIC_2_GAIN_STATUS	7:3	R	(reserved)	00000	
	2:0	R	MIC_2_AMP_GAIN_STATUS	001	Actual MIC_2 amplifier gain 000 = -6 dB 001 = 0 dB 010 = 6 dB and continuing in +6 dB steps to 111 = 36 dB

Ultra-Low Power Stereo Codec

Register address	Bit	Type	Label	Default	Description
0x08 MIXIN_L_GAIN_STATUS	7:4	R	(reserved)	0000	
	3:0	R	MIXIN_L_AMP_GAIN_STATUS	0000	Actual IN_L amplifier gain 0000 = -4.5 dB 0001 = -3 dB 0010 = -1.5 dB 0011 = 0 dB continuing in +1.5 dB steps to 1111 = 18 dB

Register address	Bit	Type	Label	Default	Description
0x09 MIXIN_R_GAIN_STATUS	7:4	R	(reserved)	0000	
	3:0	R	MIXIN_R_AMP_GAIN_STATUS	0000	Actual IN_R amplifier gain 0000 = -4.5 dB 0001 = -3 dB 0010 = -1.5 dB 0011 = 0 dB continuing in +1.5 dB steps to 1111 = 18 dB

Register address	Bit	Type	Label	Default	Description
0x0A ADC_L_GAIN_STATUS	7	R	(reserved)	0	
	6:0	R	ADC_L_DIGITAL_GAIN_STATUS	0000000	Actual ADC_L digital gain 0000000 = -83.25 dB 0000001 = -82.50 dB 0000010 = -81.75 dB continuing in +0.75 dB steps to 1111110 = 11.25 dB 1111111 = 12 dB Note: 1101111 = 0 dB

Ultra-Low Power Stereo Codec

Register address	Bit	Type	Label	Default	Description
0x0B ADC_R_GAIN_STATUS	7	R	(reserved)	0	
	6:0	R	ADC_R_DIGITAL_GAIN_STATUSES	0000000	<p>Actual ADC_R digital gain</p> <p>0000000 = -83.25 dB 0000001 = -82.50 dB 0000010 = -81.75 dB</p> <p>continuing in +0.75 dB steps to</p> <p>1111110 = 11.25 dB 1111111 = 12 dB</p> <p>Note: 1101111 = 0 dB</p>

Register address	Bit	Type	Label	Default	Description
0x0C DAC_L_GAIN_STATUS	7	R	(reserved)	0	
	6:0	R	DAC_L_DIGITAL_GAIN_STATUSES	0000000	<p>Actual DAC_L digital gain</p> <p>0000000 to 0000111 = mute 0001000 = -77.25 dB 0001001 = -76.50 dB 0001010 = -75.75 dB</p> <p>continuing in +0.75 dB steps to</p> <p>1111110 = 11.25 dB 1111111 = 12.00 dB</p> <p>Note: 1101111 = 0 dB</p>

Ultra-Low Power Stereo Codec

Register address	Bit	Type	Label	Default	Description
0x0D DAC_R_GAIN_STATUS	7	R	(reserved)	0	
	6:0	R	DAC_R_DIGITAL_GAIN_STATUS	0000000	<p>Actual DAC_R digital gain</p> <p>0000000 to 0000111 = mute 0001000 = -77.25 dB 0001001 = -76.50 dB 0001010 = -75.75 dB</p> <p>continuing in +0.75 dB steps to</p> <p>1111110 = 11.25 dB 1111111 = 12.00 dB</p> <p>Note: 1101111 = 0 dB</p>

Register address	Bit	Type	Label	Default	Description
0x0E HP_L_GAIN_STATUS	7:6	R	(reserved)	00	
	5:0	R	HP_L_AMP_GAIN_STATUS	000000	<p>Actual HP_L amplifier gain</p> <p>000000 = -57 dB 000001 = -56 dB 000010 = -55 dB</p> <p>continuing in +1 dB steps to</p> <p>111110 = 5 dB 111111 = 6 dB</p> <p>Note: 111001 = 0 dB</p>

Ultra-Low Power Stereo Codec

Register address	Bit	Type	Label	Default	Description
0x0F HP_R_GAIN_STATUS	7:6	R	(reserved)	00	
	5:0	R	HP_R_AMP_GAIN_STATUS	000000	Actual HP_R amplifier gain 000000 = -57 dB 000001 = -56 dB 000010 = -55 dB continuing in +1 dB steps to 111110 = 5 dB 111111 = 6 dB Note: 111001 = 0 dB

Register address	Bit	Type	Label	Default	Description
0x10 LINE_GAIN_STATUS	7:6	R	(reserved)	00	
	5:0	R	LINE_AMP_GAIN_STATUS	000000	Actual LINE amplifier gain 000000 = -48 dB 000001 = -47 dB continuing in +1 dB steps to 111110 = 14 dB 111111 = 15 dB Note: 110000 = 0 dB

14.3 System Initialisation Registers

Register address	Bit	Type	Label	Default	Description
0x1D CIF_CTRL	7	R/W	CIF_REG_SOFT_RESET	0	Software reset that returns all the registers back to the default. Writing to this bit causes all the registers to reset
	6:1	R/W	(reserved)	000000	

Ultra-Low Power Stereo Codec

	0	R/W	CIF_I2C_WRITE_MODE	0	<p>Mode of operation for the I2C interface</p> <p>0 = Page Mode 1 = Repeat Mode</p> <p>Note: Page Mode supports both Page Mode and Repeat Mode reads and writes. Repeat Mode only supports Repeat Mode reads and writes.</p>
--	---	-----	--------------------	---	-----------------------------------------------------------------------------------------------------------------------------------------------------------------------------------------------------------------------------------------

Register address	Bit	Type	Label	Default	Description
0x21 DIG_ROUTING_DAI	7:6	R/W	(reserved)	00	
	5:4	R/W	DAI_R_SRC	01	<p>Data select for the DAI right output stream</p> <p>00 = ADC left 01 = ADC right 10 = DAI input left data 11 = DAI input right data</p>
	3:2	R/W	(reserved)	00	
	1:0	R/W	DAI_L_SRC	00	<p>Data select for the DAI left output stream</p> <p>00 = ADC left 01 = ADC right 10 = DAI input left data 11 = DAI input right data</p>

Register address	Bit	Type	Label	Default	Description
0x22 SR	7:4	R/W	(reserved)	0000	
	3:0	R/W	SR	1010	<p>Sample rate control</p> <p>0001 = 8 kHz 0010 = 11.025 kHz 0011 = 12 kHz 0100 = reserved 0101 = 16 kHz 0110 = 22 kHz 0111 = 24 kHz 1000 = reserved 1001 = 32 kHz 1010 = 44.1 kHz (Note 24) 1011 = 48 kHz 1110 = 88.2 kHz 1111 = 96 kHz</p>

Note 24 b1011 (48 kHz) is the only valid setting when using 24-48 mode (24_48_MODE = 1)

Ultra-Low Power Stereo Codec

Register address	Bit	Type	Label	Default	Description
0x23 REFERENC ES	7	R/W	(reserved)	1	
	6	R/W	(reserved)	0	
	5	R/W	VMID_FAST_DI SCHARGE	0	VMID fast discharge enable: 0 = low noise slow discharge mode 1 = high noise fast discharge mode
	4	R/W	VMID_FAST_CH ARGE	0	VMID fast charge enable: 0 = low noise slow charge mode 1 = high noise fast charge mode
	3	R/W	BIAS_EN	0	Master bias enable: 0 = disabled 1 = enabled
	2	R/W	(reserved)	0	
	1:0	R/W	(reserved)	00	

Register address	Bit	Type	Label	Default	Description
0x24 PLL_FRAC_ TOP	7:5	R/W	(reserved)	000	
	4:0	R/W	PLL_FBDIV_FR AC_TOP	00000	PLL fractional division value (top bits). The full PLL fractional division value is a concatenation of these bits (MSB) and PLL_FBDIV_FRAC_BOT (LSB)

Register address	Bit	Type	Label	Default	Description
0x25 PLL_FRAC_ BOT	7:0	R/W	PLL_FBDIV_FR AC_BOT	0000000 0	PLL fractional division value (bottom bits). The full PLL fractional division value is a concatenation of PLL_FBDIV_FRAC_TOP (MSB) and these bits (LSB)

Register address	Bit	Type	Label	Default	Description
0x26 PLL_INTEG ER	7	R/W	(reserved)	0	
	6:0	R/W	PLL_FBDIV_INT EGER	0100000	PLL integer division value

Ultra-Low Power Stereo Codec

Register address	Bit	Type	Label	Default	Description
0x27 PLL_CTRL	7	R/W	PLL_EN	0	PLL enable: 0 = system clock is MCLK 1 = system clock is PLL output
	6	R/W	PLL_SRM_EN	0	PLL sample rate tracking enable: 0 = SRM disabled 1 = SRM enabled
	5	R/W	PLL_32K_MODE	0	Sets the PLL into 32 kHz mode: 0 = disabled 1 = enabled
	4	R/W	PLL_MCLK_SQR_EN	0	Enables the squarer at the MCLK: 0 = disabled 1 = enabled
	3:2	R/W	PLL_INDIV	11	Sets the input clock range for the PLL: 00 = 2 - 10 MHz 01 = 10 - 20 MHz 10 = 20 - 40 MHz 11 = 40 - 80 MHz
	1:0	R/W	(reserved)	00	

Register address	Bit	Type	Label	Default	Description
0x28 DAI_CLK_MODE	7	R/W	DAI_CLK_EN	0	DAI master mode enable: 0 = slave mode (BCLK/WCLK inputs) 1 = master mode (BCLK/WCLK outputs)
	6:4	R/W	(reserved)	000	
	3	R/W	DAI_WCLK_POL	0	DAI word clock polarity: 0 = normal polarity 1 = inverted polarity
	2	R/W	DAI_CLK_POL	0	DAI bit clock polarity: 0 = normal 1 = inverted
	1:0	R/W	DAI_BCLKS_PER_WCLK	01	DAI master mode BCLK number per WCLK period: 00 = BCLK = 32 01 = BCLK = 64 10 = BCLK = 128 11 = BCLK = 256

Register address	Bit	Type	Label	Default	Description
0x29 DAI_CTRL	7	R/W	DAI_EN	0	DAI enable: 0 = disabled 1 = enabled
	6	R/W	DAI_OE	0	DAI output enable: 0 = DATOUT pin is high impedance 1 = DATOUT pin is driven when required
	5	R/W	DAI_TDM_MODE_EN	0	DAI TDM mode enable: 0 = DAI normal mode 1 = DAI TDM mode
	4	R/W	DAI_MONO_MODE_EN	0	DAI mono mode enable: 0 = DAI stereo mode 1 = DAI mono mode DAI mono mode can only be enabled when the DSP data format = DSP Mode (DAI_FORMAT = 11)
	3:2	R/W	DAI_WORD_LENGTH	10	DAI data word length: 00 = 16 bits per channel 01 = 20 bits per channel 10 = 24 bits per channel 11 = 32 bits per channel
	1:0	R/W	DAI_FORMAT	00	DAI data format: 00 = I2S mode 01 = left justified mode 10 = right justified mode 11 = DSP mode

Register address	Bit	Type	Label	Default	Description
0x2A DIG_ROUTING_DAC	7	R/W	DAC_R_MONO	0	When asserted, the DAI right input stream is replaced with a mono mix of left and right 0 = Right input stream 1 = Mono mix of left and right input streams
	6	R/W	(reserved)	0	
	5:4	R/W	DAC_R_SRC	11	Data select to the DAC_R path: 00 = ADC left output 01 = ADC right output 10 = Determined by DAC_L_MONO (bit [3] of this register) 11 = Determined by DAC_R_MONO (bit [7] of this register) Note: The beep generator is omitted from the signal path if this is set to '00' or '01'
	3	R/W	DAC_L_MONO	0	When asserted, the DAI left input stream is replaced with a mono mix of left and right 0 = Left input stream 1 = Mono mix of left and right input streams
	2	R/W	(reserved)	0	
	1:0	R/W	DAC_L_SRC	10	Data select to the DAC_L path: 00 = ADC left output 01 = ADC right output 10 = Determined by DAC_L_MONO (bit [3] of this register) 11 = Determined by DAC_R_MONO (bit [7] of this register) The beep generator is omitted from the signal path if this is set to '00' or '01'

Register address	Bit	Type	Label	Default	Description
0x2B ALC_CTRL1	7	R/W	ALC_R_EN	0	Enables the ALC operation on the right ADC channel: 0 = disabled 1 = enabled
	6	R/W	(reserved)	0	
	5	R	ALC_CALIB_OVERFLOW	0	Offset overflow during calibration 0 = no offset overflow 1 = offset overflow
	4	R/W	ALC_AUTO_CALIB_EN	0	Automatic calibration enable (self clearing bit) 0 = disabled 1 = enabled
	3	R/W	ALC_L_EN	0	Enables the ALC operation on the left ADC channel: 0 = disabled 1 = enabled
	2	R/W	ALC_CALIB_MODE	0	Calibration mode 0 = Automatic calibration 1 = Manual calibration
	1	R/W	ALC_SYNC_MODE	0	Selects the ALC Operation Mode: 0 = Full digital gain solution 1 = Mixed digital/analogue gain solution
	0	R/W	ALC_OFFSET_EN	0	Enable DC Offset cancellation: 0 = disabled 1 = enabled

14.4 Input Gain/Select Filter Registers

Register address	Bit	Type	Label	Default	Description
0x30 AUX_L_GAIN	7:6	R/W	(reserved)	00	
	5:0	R/W	AUX_L_AMP_GAIN	110101	Gain setting for the AUX left amplifier (1.5 dB step): 000000 to 010001 = -54 dB 010010 = -52.5 dB 010011 = -51 dB continuing in +1.5 dB steps to 111110 = 13.5 dB 111111 = 15 dB Note: 110101 = 0 dB (default)

Ultra-Low Power Stereo Codec

Register address	Bit	Type	Label	Default	Description
0x31 AUX_R_GAIN	7:6	R/W	(reserved)	00	
	5:0	R/W	AUX_R_AMP_GAIN	110101	Gain setting for the AUX right amplifier (1.5 dB step): 000000 to 010001 = -54 dB 010010 = -52.5 dB 010011 = -51 dB continuing in +1.5 dB steps to 111110 = 13.5 dB 111111 = 15 dB Note: 110101 = 0 dB (default)

Register address	Bit	Type	Label	Default	Description
0x32 MIXIN_L_SELECT	7	R/W	DMIC_L_EN	0	Enable the left DMIC input: 0 = disabled 1 = enabled
	6	R/W	(reserved)	0	
	5:4	R/W	(reserved)	00	
	3	R/W	MIXIN_R	0	0 = MIXIN_R not mixed in 1 = MIXIN_R mixed in
	2	R/W	MIC2_SEL	0	0 = MIC2 input not mixed in 1 = MIC2 input mixed in
	1	R/W	MIC1_SEL	0	0 = MIC1 input not mixed in 1 = MIC1 input mixed in
	0	R/W	AUX_L_SEL	0	0 = AUX_L input not mixed in 1 = AUX_L input mixed in

Ultra-Low Power Stereo Codec

Register address	Bit	Type	Label	Default	Description
0x33 MIXIN_R_SELECT	7	R/W	DMIC_R_EN	0	Enable the right DMIC input: 0 = disabled 1 = enabled
	6	R/W	(reserved)	0	
	5:4	R/W	(reserved)	00	
	3	R/W	MIXIN_L_SEL	0	0 = MIXIN_L input not mixed in 1 = MIXIN_L input mixed in
	2	R/W	MIC1_SEL	0	0 = MIC_1 input not mixed in 1 = MIC_1 input mixed in
	1	R/W	MIC2_SEL	0	0 = MIC_2 input not mixed in 1 = MIC_2 input mixed in
	0	R/W	AUX_R_SEL	0	0 = AUX_R input not mixed in 1 = AUX_R input mixed in

Register address	Bit	Type	Label	Default	Description
0x34 MIXIN_L_GAIN	7:4	R/W	(reserved)	0000	
	3:0	R/W	MIXIN_L_AMP_GAIN	0011	Gain setting for the IN left amplifier (1.5 dB step): 0000 = -4.5 dB 0001 = -3 dB 0010 = -1.5 dB 0011 = 0 dB continuing in +1.5 dB steps to 1111 = 18 dB

Register address	Bit	Type	Label	Default	Description
0x35 MIXIN_R_GAIN	7:4	R/W	(reserved)	0000	
	3:0	R/W	MIXIN_R_AMP_GAIN	0011	Gain setting for the IN right amplifier (1.5 dB step): 0000 = -4.5 dB 0001 = -3 dB 0010 = -1.5 dB 0011 = 0 dB continuing in +1.5 dB steps to 1111 = 18 dB

Ultra-Low Power Stereo Codec

Register address	Bit	Type	Label	Default	Description
0x36 ADC_L_GAIN	7	R/W	(reserved)	0	
	6:0	R/W	ADC_L_DIGITAL_GAIN	1101111	ADC left digital gain (0.75 dB step): 0000000 = -83.25 dB 0000001 = -82.50 dB 0000010 = -81.75 dB continuing in +0.75 dB steps to 1111110 = 11.25 dB 1111111 = 12 dB Note: 1101111 = 0 dB (default)

Register address	Bit	Type	Label	Default	Description
0x37 ADC_R_GAIN	7	R/W	(reserved)	0	
	6:0	R/W	ADC_R_DIGITAL_GAIN	1101111	ADC right digital gain (0.75 dB step): 0000000 = -83.25 dB 0000001 = -82.50 dB 0000010 = -81.75 dB continuing in +0.75 dB steps to 1111110 = 11.25 dB 1111111 = 12 dB Note: 1101111 = 0 dB (default)

Ultra-Low Power Stereo Codec

Register address	Bit	Type	Label	Default	Description
0x38 ADC_FILTERS1	7	R/W	ADC_HPF_EN	1	ADC high pass filter enable: 0 = disabled 1 = enabled
	6	R/W	(reserved)	0	
	5:4	R/W	ADC_AUDIO_HPF_CORNER	00	Cut-off frequency at the 3 dB for the High Pass Filter at 48 kHz (for other frequencies see Table 30): 00 = 2 Hz 01 = 4 Hz 10 = 8 Hz 11 = 16 Hz
	3	R/W	ADC_VOICE_EN	0	ADC voice filter enable: 0 = disabled 1 = enabled
	2:0	R/W	ADC_VOICE_HPF_CORNER	000	Cut-off frequency at the 3 dB for the Voice Filter at 8 kHz (for other frequencies see Table 31): 000 = 2.5 Hz 001 = 25 Hz, 010 = 50 Hz 011 = 100 Hz 100 = 150 Hz 101 = 200 Hz 110 = 300 Hz 111 = 400 Hz

Register address	Bit	Type	Label	Default	Description
0x39 MIC_1_GAIN	7:3	R/W	(reserved)	00000	
	2:0	R/W	MIC_1_AMP_GAIN	001	Gain setting for the MIC left amplifier (6 dB step): 000 = -6 dB 001 = 0 dB 010 = 6 dB continuing in 6 dB steps to 111 = 36 dB This setting is ignored if the ALC is enabled (ALC_R_EN or ALC_L_EN = 1) and the ALC is running in Synchronised Mode (ALC_SYNC_MODE = 1)

Ultra-Low Power Stereo Codec

Register address	Bit	Type	Label	Default	Description
0x3A MIC_2_GAIN	7:3	R/W	(reserved)	00000	
	2:0	R/W	MIC_2_AMP_GAIN	001	Gain setting for the MIC right amplifier (6 dB step): 000 = -6 dB 001 = 0 dB 010 = 6 dB continuing in 6 dB steps to 111 = 36 dB This setting is ignored if the ALC is enabled (ALC_R_EN or ALC_L_EN = 1) and the ALC is running in Synchronised Mode (ALC_SYNC_MODE = 1)

14.5 Output Gain-Filter Registers

Register address	Bit	Type	Label	Default	Description
0x40 DAC_FILTERS5	7	R/W	DAC_SOFTMUTE_EN	0	DAC soft mute enable on both channels: 0 = disabled 1 = enabled
	6:4	R/W	DAC_SOFTMUTE_RATE	000	Softmute gain update rate (samples per 0.1875 dB): 000 = 1 001 = 2 010 = 4 011 = 8 100 = 16 101 = 32 110 = 64 111 = reserved
	3:0	R/W	(reserved)	0000	

Ultra-Low Power Stereo Codec

Register address	Bit	Type	Label	Default	Description
0x41 DAC_FILTE RS2	7:4	R/W	DAC_EQ_BAND 2	1000	Gain setting for the DAC 5-Band EQ band 2 (1.5 dB steps). 0000 = -10.5 dB 0001 = -9 dB continuing in +1.5 dB steps to 1110 = 10.5 dB 1111 = 12 dB Note: 0111 = 0 dB Note: 1000 = 1.5 dB (default)
	3:0	R/W	DAC_EQ_BAND 1	1000	Gain setting for the DAC 5-Band EQ band 1 (1.5 dB steps): 0000 = -10.5 dB 0001 = -9 dB continuing in +1.5 dB steps to 1110 = 10.5 dB 1111 = 12 dB Note: 0111 = 0 dB Note: 1000 = 1.5 dB (default)

Ultra-Low Power Stereo Codec

Register address	Bit	Type	Label	Default	Description
0x42 DAC_FILTE RS3	7:4	R/W	DAC_EQ_BAND 4	1000	Gain setting for the DAC 5-Band EQ band 4 (1.5 dB steps). 0000 = -10.5 dB 0001 = -9 dB continuing in +1.5 dB steps to 1110 = 10.5 dB 1111 = 12 dB Note: 0111 = 0 dB Note: 1000 = 1.5 dB (default)
	3:0	R/W	DAC_EQ_BAND 3	1000	Gain setting for the DAC 5-Band EQ band 3 (1.5 dB steps): 0000 = -10.5 dB 0001 = -9 dB continuing in +1.5 dB steps to 1110 = 10.5 dB 1111 = 12 dB Note: 0111 = 0 dB Note: 1000 = 1.5 dB (default)

Register address	Bit	Type	Label	Default	Description
0x43 DAC_FILTE RS4	7	R/W	DAC_EQ_EN	0	DAC 5-band equaliser enable: 0 = disabled 1 = enabled
	6:4	R/W	(reserved)	000	
	3:0	R/W	DAC_EQ_BAND 5	1000	Gain setting for the DAC 5-Band EQ band 5 (1.5 dB steps): 0000 = -10.5 dB 0001 = -9 dB continuing in +1.5 dB steps to 1110 = 10.5 dB 1111 = 12 dB Note: 0111 = 0 dB Note: 1000 = 1.5 dB (default)

Ultra-Low Power Stereo Codec

Register address	Bit	Type	Label	Default	Description
0x44 DAC_FILTERS1	7	R/W	DAC_HPF_EN	1	DAC High Pass filter enable: 0 = disabled 1 = enabled
	6	R/W	(reserved)	0	
	5:4	R/W	DAC_AUDIO_HPF_CORNER	00	Cut-off frequency at the 3 dB for the High Pass Filter at 48 kHz (for other frequencies see Table 30): 00 = 2 Hz 01 = 4 Hz 10 = 8 Hz 11 = 16 Hz
	3	R/W	DAC_VOICE_EN	0	DAC voice filter enable: 0 = disabled 1 = enabled This DAC Voice Filter control overrides the 5-band EQ setting in DAC_EQ_EN
	2:0	R/W	DAC_VOICE_HPF_CORNER	000	Cut-off frequency at the 3 dB for the Voice Filter at 8 kHz (for other frequencies see Table 31): 000 = 2.5 Hz 001 = 25 Hz 010 = 50 Hz 011 = 100 Hz 100 = 150 Hz 101 = 200 Hz 110 = 300 Hz 111 = 400 Hz

Register address	Bit	Type	Label	Default	Description
0x45 DAC_L_GAIN	7	R/W	(reserved)	0	
	6:0	R/W	DAC_L_DIGITAL_GAIN	1101111	DAC left digital gain (0.75 dB step): 0000000 to 0000111 = mute 0001000 = -77.25 dB 0001001 = -76.50 dB 0001010 = -75.75 dB continuing in +0.75 dB steps to 1111110 = 11.25 dB 1111111 = 12.00 dB Note: 1101111 = 0 dB (default)

Ultra-Low Power Stereo Codec

Register address	Bit	Type	Label	Default	Description
0x46 DAC_R_GAIN	7	R/W	(reserved)	0	
	6:0	R/W	DAC_R_DIGITAL_GAIN	1101111	DAC right digital gain (0.75 dB step): 0000000 to 0000111 = mute 0001000 = -77.25 dB 0001001 = -76.50 dB 0001010 = -75.75 dB continuing in +0.75 dB steps to 1111110 = 11.25 dB 1111111 = 12.00 dB Note: 1101111 = 0 dB (default)

Register address	Bit	Type	Label	Default	Description
0x47 CP_CTRL	7	R/W	CP_EN	0	Charge pump enable: 0 = disabled 1 = enabled
	6	R/W	CP_SMALL_SWITCH_FREQ_EN	1	Charge pump low-load low-power mode enable: 0 = disabled 1 = enabled
	5:4	R/W	CP_MCHANGE	10	Charge pump tracking mode select: 00 = voltage level is controlled by CP_MOD 01 = voltage level is controlled by the output PGA gain setting 10 = voltage level is controlled by the DAC signal level 11 = voltage level is controlled by the output signal magnitude
	3:2	R/W	CP_MOD	00	Charge pump manual mode level control: 00 = standby 01 = reserved 10 = CPVDD/2 11 = CPVDD/1
	1:0	R/W	CP_ANALOGUE_LVL	01	Charge pump analogue feedback control mode: 00 = no feedback 01 = low voltage indicator boosts charge pump 10 = low voltage indicator restarts charge pump cycle 11 = Reserved

Ultra-Low Power Stereo Codec

Register address	Bit	Type	Label	Default	Description
0x48 HP_L_GAIN	7:6	R/W	(reserved)	00	
	5:0	R/W	HP_L_AMP_GAIN	111001	Headphone left amplifier gain (1 dB step): 000000 = -57 dB 000001 = -56 dB 000010 = -55 dB continuing in +1 dB steps to 111110 = 5 dB 111111 = 6 dB Note: 111001 = 0 dB (default)

Register address	Bit	Type	Label	Default	Description
0x49 HP_R_GAIN	7:6	R/W	(reserved)	00	
	5:0	R/W	HP_R_AMP_GAIN	111001	Headphone right amplifier gain (1 dB step): 000000 = -57 dB 000001 = -56 dB 000010 = -55 dB continuing in +1 dB steps to 111110 = 5 dB 111111 = 6 dB Note: 111001 = 0 dB (default)

Register address	Bit	Type	Label	Default	Description
0x4A LINE_GAIN	7:6	R/W	(reserved)	00	
	5:0	R/W	LINE_AMP_GAIN	110000	LINE amplifier gain (1 dB step) 000000 = -48 dB 000001 = -47 dB continuing in +1 dB steps to 111110 = 14 dB 111111 = 15 dB Note: 110000 = 0 dB (default)

Ultra-Low Power Stereo Codec

Register address	Bit	Type	Label	Default	Description
0x4B MIXOUT_L_SELECT	7	R/W	(reserved)	0	
	6	R/W	MIXIN_R_INV	0	MIXIN R Inverted control 0 = Inverted MIXIN R not selected 1 = Inverted MIXIN R selected
	5	R/W	MIXIN_L_INV	0	MIXIN L Inverted control 0 = Inverted MIXIN L not selected 1 = Inverted MIXIN L selected
	4	R/W	AUX_L_INV	0	AUX L Inverted control 0 = Inverted AUX_L not selected 1 = Inverted AUX_L selected
	3	R/W	DAC_L	0	DAC L control 0 = DAC_L not selected 1 = DAC_L selected
	2	R/W	MIXIN_R	0	MIXIN R control 0 = MIXIN_R not selected 1 = MIXIN_R selected
	1	R/W	MIXIN_L	0	MIXIN L control 0 = MIXIN_L not selected 1 = MIXIN_L selected
	0	R/W	AUX_L	0	AUX_L control 0 = AUX_L not selected 1 = AUX_L selected

Ultra-Low Power Stereo Codec

Register address	Bit	Type	Label	Default	Description
0x4C MIXOUT_R_SELECT	7	R/W	(reserved)	0	
	6	R/W	MIXIN_L_INV	0	MIXIN L Inverted control 0 = Inverted MIXIN L not selected 1 = Inverted MIXIN L selected
	5	R/W	MIXIN_R_INV	0	MIXIN R Inverted control 0 = Inverted MIXIN R not selected 1 = Inverted MIXIN R selected
	4	R/W	AUX_R_INV	0	AUX R Inverted control 0 = Inverted AUX_R not selected 1 = Inverted AUX_R selected
	3	R/W	DAC_R	0	DAC R control 0 = DAC_R not selected 1 = DAC_R selected
	2	R/W	MIXIN_L	0	MIXIN L control 0 = MIXIN_L not selected 1 = MIXIN_L selected
	1	R/W	MIXIN_R	0	MIXIN R control 0 = MIXIN_R not selected 1 = MIXIN_R selected
	0	R/W	AUX_R	0	AUX_R control 0 = AUX_R not selected 1 = AUX_R selected

14.6 System Controller Registers

Register address	Bit	Type	Label	Default	Description
0x50 SYSTEM_M ODES_INP UT	7	R/W	ADC_R	0	Preconfigured system mode - ADC_R Control 0 = ADC_R not used 1 = use ADC R
	6	R/W	ADC_L	0	Preconfigured system mode - ADC_L Control 0 = ADC_L not used 1 = use ADC L
	5	R/W	MIXIN_R	0	Preconfigured system mode – IN_R Control 0 = IN R amplifier not used 1 = use IN_R amplifier
	4	R/W	MIXIN_L	0	Preconfigured system mode – IN_L Control 0 = IN L amplifier not used 1 = use IN_L amplifier
	3	R/W	MIC_2	0	Preconfigured system mode – MIC_2 Control 0 = MIC 2 amplifier not used 1 = use MIC 2 amplifier
	2	R/W	MIC_1	0	Preconfigured system mode – MIC_1 Control 0 = MIC 1 amplifier not used 1 = use MIC 1 amplifier
	1	R/W	(Reserved)	0	
	0	R/W	MODE_SUBMIT	0	System Controller 2 activation control 0 = ADC_mode and DAC_mode inactive 1 = ADC_mode and DAC_mode active This register bit is a duplicate of MODE_SUBMIT (reg 0x51[0]). Either register can be used to activate System Controller 2. This bit is self-clearing.

Ultra-Low Power Stereo Codec

Register address	Bit	Type	Label	Default	Description
0x51 SYSTEM_M ODES_OUT PUT	7:3	R/W	DAC_R	0	Preconfigured system mode – DAC_R Control 0 = DAC_R not used 1 = use DAC R
	6	R/W	DAC_L	0	Preconfigured system mode – DAC_L Control 0 = DAC_L not used 1 = use DAC L
	5	R/W	HP_R	0	Preconfigured system mode – HP_R Control 0 = HP_R not used 1 = use HP_R amplifier
	4	R/W	HP_L	0	Preconfigured system mode – HP_L Control 0 = HP_L not used 1 = use HP_L amplifier
	3	R/W	LINE	0	Preconfigured system mode – LINE Control 0 = LINE not used 1 = use LINE amplifier
	2	R/W	AUX_R	0	Preconfigured system mode – AUX_R Control 0 = AUX_R amplifier not used 1 = use AUX_R amplifier
	1	R/W	AUX_L	0	Preconfigured system mode – AUX_L Control 0 = AUX_L amplifier not used 1 = use AUX_L amplifier
	0	R/W	MODE_SUBMIT	0	System Controller 2 activation control 0 = ADC_mode and DAC_mode inactive 1 = ADC_mode and DAC_mode active This register bit is a duplicate of MODE_SUBMIT (reg 0x51[0]). Either register can be used to activate System Controller 2. This bit is self-clearing.

14.7 Control Registers

Register address	Bit	Type	Label	Default	Description
0x60 AUX_L_CTL	7	R/W	AUX_L_AMP_EN	0	AUX_L amplifier enable: 0 = disabled 1 = enabled
	6	R/W	AUX_L_AMP_MUTE_EN	1	AUX_L amplifier mute enable: 0 = disabled 1 = enabled
	5	R/W	AUX_L_AMP_RAMP_EN	0	AUX_L amplifier gain ramping enable (overrides zero crossing): 0 = disabled 1 = enabled
	4	R/W	AUX_L_AMP_ZERO_CROSS_EN	0	AUX_L amplifier zero cross gain update mode enable: 0 = disabled 1 = enabled
	3:2	R/W	AUX_L_AMP_ZERO_CROSS_SEL	01	Selects where the zero cross detection on the AUX_L input is measured: 00 = Input of AUX_L amplifier 01 = input of AUX_L amplifier if gain ≤ 4.5 dB otherwise on the output 10 = Neither (no zero cross possible) 11 = Output of AUX_L amplifier
	1:0	R/W	(reserved)	00	

Ultra-Low Power Stereo Codec

Register address	Bit	Type	Label	Default	Description
0x61 AUX_R_CTL	7	R/W	AUX_R_AMP_EN	0	AUX_R amplifier enable: 0 = disabled 1 = enabled
	6	R/W	AUX_R_AMP_MUTE_EN	1	AUX_R amplifier mute enable: 0 = disabled 1 = enabled
	5	R/W	AUX_R_AMP_RAMP_EN	0	AUX_R amplifier gain ramping enable (overrides zero crossing): 0 = disabled 1 = enabled
	4	R/W	AUX_R_AMP_ZERO_CROSS_EN	0	AUX_R amplifier zero cross gain update mode enable: 0 = disabled 1 = enabled
	3:2	R/W	AUX_R_AMP_ZERO_CROSS_SEL	01	Selects where the zero cross detection on the AUX_R input is measured: 00 = Input of AUX_R amplifier 01 = input of AUX_R amplifier if gain ≤ 4.5 dB otherwise on the output 10 = Neither (no zero cross possible) 11 = Output of AUX_R amplifier
	1:0	R/W	(reserved)	00	

Ultra-Low Power Stereo Codec

Register address	Bit	Type	Label	Default	Description
0x62 MICBIAS_C TRL	7	R/W	MICBIAS2_EN	0	Microphone 2 bias enable: 0 = Disable 1 = Enable
	6	R/W	(reserved)	0	
	5:4	R/W	MICBIAS2_LEV EL	01	Microphone 2 bias level 00 = 1.6 V 01 = 2.2 V 10 = 2.5 V 11 = 3.0 V
	3	R/W	MICBIAS1_EN	0	Microphone 1 bias enable: 0 = Disable 1 = Enable
	2	R/W	(reserved)	0	
	1:0	R/W	MICBIAS1_LEV EL	01	Microphone 1 bias level 00 = 1.6 V 01 = 2.2 V 10 = 2.5 V 11 = 3.0 V

Register address	Bit	Type	Label	Default	Description
0x63 MIC_1_CTR L	7	R/W	MIC_1_AMP_EN	0	MIC_1 amplifier enable: 0 = disabled 1 = enabled
	6	R/W	MIC_1_AMP_M UTE_EN	1	MIC_1 amplifier mute enable: 0 = amplifier unmuted 1 = amplifier muted
	5	R/W	(reserved)	0	
	4	R/W	(reserved)	0	
	3:2	R/W	MIC_1_AMP_IN _SEL	00	MIC_1 input source select: 00 = differential 01 = MIC_1_P single-ended 10 = MIC_1_N single-ended 11 = reserved
	1:0	R/W	(reserved)	00	

Ultra-Low Power Stereo Codec

Register address	Bit	Type	Label	Default	Description
0x64 MIC_2_CTRL	7	R/W	MIC_2_AMP_EN	0	MIC_2 amplifier enable: 0 = disabled 1 = enabled
	6	R/W	MIC_2_AMP_MUTE_EN	1	MIC_2 amplifier mute enable: 0 = amplifier unmuted 1 = amplifier muted
	5	R/W	(reserved)	0	
	4	R/W	(reserved)	0	
	3:2	R/W	MIC_2_AMP_IN_SEL	00	MIC_2 input source select: 00 = differential 01 = MIC_2_P single-ended 10 = MIC_2_N single-ended 11 = reserved
	1:0	R/W	(reserved)	00	

Register address	Bit	Type	Label	Default	Description
0x65 MIXIN_L_CTRL	7	R/W	MIXIN_L_AMP_EN	0	MIXIN_L amplifier enable: 0 = disabled 1 = enabled
	6	R/W	MIXIN_L_AMP_MUTE_EN	1	MIXIN_L amplifier mute enable: 0 = disabled 1 = enabled
	5	R/W	MIXIN_L_AMP_RAMP_EN	0	MIXIN_L amplifier gain ramping enable (overrides zero crossing): 0 = disabled 1 = enabled
	4	R/W	MIXIN_L_AMP_ZC_EN	0	MIXIN_L amplifier zero cross gain update mode enable: 0 = disabled 1 = enabled
	3	R/W	MIXIN_L_MIX_EN	0	MIXIN_L mixer enable. When disabled all inputs are deselected: 0 = mixer disabled 1 = mixer enabled
	2	R/W	(reserved)	0	
	1:0	R/W	(reserved)	00	

Register address	Bit	Type	Label	Default	Description
0x66 MIXIN_R_C TRL	7	R/W	MIXIN_R_AMP_ EN	0	MIXIN_R amplifier enable: 0 = disabled 1 = enabled
	6	R/W	MIXIN_R_AMP_ MUTE_EN	1	MIXIN_R amplifier mute enable: 0 = disabled 1 = enabled
	5	R/W	MIXIN_R_AMP_ RAMP_EN	0	MIXIN_R amplifier gain ramping enable (overrides zero crossing): 0 = disabled 1 = enabled
	4	R/W	MIXIN_R_AMP_ ZC_EN	0	MIXIN_R amplifier zero cross gain update mode enable: 0 = disabled 1 = enabled
	3	R/W	MIXIN_R_MIX_E N	0	MIXIN_R mixer enable. When disabled all inputs are deselected: 0 = mixer disabled 1 = mixer enabled
	2	R/W	(reserved)	0	
	1:0	R/W	(reserved)	00	

Register address	Bit	Type	Label	Default	Description
0x67 ADC_L_CT RL	7	R/W	ADC_L_EN	0	ADC_L enable: 0 = disabled 1 = enabled
	6	R/W	ADC_L_MUTE_ EN	1	ADC_L mute enable: 0 = disabled 1 = enabled
	5	R/W	ADC_L_RAMP_ EN	0	ADC_L digital gain ramping enable (overrides zero crossing): 0 = disabled 1 = enabled
	4:2	R/W	(reserved)	000	
	1:0	R/W	(reserved)	00	

Ultra-Low Power Stereo Codec

Register address	Bit	Type	Label	Default	Description
0x68 ADC_R_CTL	7	R/W	ADC_R_EN	0	ADC_R enable: 0 = disabled 1 = enabled
	6	R/W	ADC_R_MUTE_EN	1	ADC_R mute enable: 0 = disabled 1 = enabled
	5	R/W	ADC_R_RAMP_EN	0	ADC_R digital gain ramping enable (overrides zero crossing): 0 = disabled 1 = enabled
	4:2	R/W	(reserved)	000	
	1:0	R/W	(reserved)	00	

Register address	Bit	Type	Label	Default	Description
0x69 DAC_L_CTL	7	R/W	DAC_L_EN	0	DAC_L enable: 0 = disabled 1 = enabled
	6	R/W	DAC_L_MUTE_EN	1	DAC_L mute enable: 0 = disabled 1 = enabled
	5	R/W	DAC_L_RAMP_EN	0	DAC_L digital gain ramping enable (overrides zero crossing): 0 = disabled 1 = enabled
	4	R/W	(reserved)	0	
	3	R/W	(reserved)	1	
	2:0	R/W	(reserved)	000	

Ultra-Low Power Stereo Codec

Register address	Bit	Type	Label	Default	Description
0x6A DAC_R_CTRL	7	R/W	DAC_R_EN	0	DAC_R enable: 0 = disabled 1 = enabled
	6	R/W	DAC_R_MUTE_EN	1	DAC_R mute enable: 0 = disabled 1 = enabled
	5	R/W	DAC_R_RAMP_EN	0	DAC_R digital gain ramping enable (overrides zero crossing): 0 = disabled 1 = enabled
	4	R/W	(reserved)	0	
	3:0	R/W	(reserved)	000	

Register address	Bit	Type	Label	Default	Description
0x6B HP_L_CTRL	7	R/W	HP_L_AMP_EN	0	HP_L amplifier enable: 0 = disabled 1 = enabled
	6	R/W	HP_L_AMP_MUTE_EN	1	HP_L amplifier mute enable: 0 = disabled 1 = enabled
	5	R/W	HP_L_AMP_RAMP_EN	0	HP_L amplifier gain ramping enable (overrides zero crossing): 0 = disabled 1 = enabled
	4	R/W	HP_L_AMP_ZC_EN	0	HP_L amplifier zero cross gain update mode enable: 0 = disabled 1 = enabled
	3	R/W	HP_L_AMP_OE	0	HP_L amplifier output enable: 0 = output is high impedance 1 = output is driven
	2	R/W	HP_L_AMP_MIN_GAIN_EN	0	HP_L amplifiers gain held at the minimum value: 0 = normal gain operation 1 = minimum gain
	1:0	R/W	(reserved)	01	

Ultra-Low Power Stereo Codec

Register address	Bit	Type	Label	Default	Description
0x6C HP_R_CTRL	7	R/W	HP_R_AMP_EN	0	HP_R amplifier enable: 0 = disabled 1 = enabled
	6	R/W	HP_R_AMP_MUTE_EN	1	HP_R amplifier mute enable: 0 = disabled 1 = enabled
	5	R/W	HP_R_AMP_RAMP_EN	0	HP_R amplifier gain ramping enable (overrides zero crossing): 0 = disabled 1 = enabled
	4	R/W	HP_R_AMP_ZC_EN	0	HP_R amplifier zero cross gain update mode enable: 0 = disabled 1 = enabled
	3	R/W	HP_R_AMP_OE	0	HP_R amplifier output enable: 0 = output is high impedance 1 = output is driven
	2	R/W	HP_R_AMP_MIN_GAIN_EN	0	HP_R amplifiers gain held at the minimum value: 0 = normal gain operation 1 = minimum gain
	1:0	R/W	(reserved)	00	

Ultra-Low Power Stereo Codec

Register address	Bit	Type	Label	Default	Description
0x6D LINE_CTRL	7	R/W	LINE_AMP_EN	0	LINE amplifier enable: 0 = disabled 1 = enabled
	6	R/W	LINE_AMP_MUTE_EN	1	LINE amplifier mute enable: 0 = disabled 1 = enabled
	5	R/W	LINE_AMP_RAMP_EN	0	LINE amplifier gain ramping enable (overrides zero crossing): 0 = disabled 1 = enabled
	4	R/W	(reserved)	0	
	3	R/W	LINE_AMP_OE	0	LINE amplifier output enable: 0 = output is high impedance 1 = output is driven
	2	R/W	LINE_AMP_MIN_GAIN_EN	0	LINE amplifiers gain held at the minimum value: 0 = normal gain operation 1 = minimum gain
	1:0	R/W	(reserved)	00	

Register address	Bit	Type	Label	Default	Description
0x6E MIXOUT_L_CTRL	7	R/W	MIXOUT_L_AMP_EN	0	MIXOUT_L mixer amp enable: 0 = disabled 1 = enabled
	6	R/W	(reserved)	0	
	5	R/W	(reserved)	0	
	4	R/W	MIXOUT_L_SOFTMIX_EN	1	MIXOUT L soft mix enable. When enabled, the gain of any signal that is added to the mixer is ramped up or down at a rate determined by the GAIN_RAMP_RATE (0x92[1:0]) setting 0 = disabled 1 = enabled
	3	R/W	MIXOUT_L_MIX_EN	0	MIXOUT L mixer enable: 0 = disabled 1 = enabled
	2	R/W	(reserved)	0	
	1:0	R/W	(reserved)	00	

Register address	Bit	Type	Label	Default	Description
0x6F MIXOUT_R_CTRL	7	R/W	MIXOUT_RAMP_EN	0	MIXOUT_R mixer amp enable: 0 = disabled 1 = enabled
	6:5	R/W	(reserved)	00	
	4	R/W	MIXOUT_R_SOFTMIX_EN	1	MIXOUT R soft mix enable. When enabled, the gain of any signal that is added to the mixer is ramped up or down at a rate determined by the GAIN_RAMP_RATE (0x92[1:0]) setting 0 = disabled 1 = enabled
	3	R/W	MIXOUT_R_MIX_EN	0	MIXOUT R mixer enable: 0 = disabled 1 = enabled
	2:0	R/W	(reserved)	000	

14.8 Mixed Sample Mode Registers

Register Address	Bit	Type	Label	Default	Description
0x84 MIXED_SAMPLE_MODE	7:1	R/W	(reserved)	0000000	
	0	R/W	24_48_MODE	0	Enables the 24_48_MODE of operation. When this bit is asserted, 24_48_MODE is activated. The ADC path runs at 24 kHz and the rest of the system, including the DAC path, at 48 kHz. Note: in 24_48_MODE, the system sample rate, which is controlled by bit SR at register address 0x22[3:0], must be set to 1010, or 48 kHz. This will make the I2S also run at 48 kHz and so the ADC output, running at 24 kHz, will be double sampled. 0 = Both ADC and DAC paths run at a speed determined by the setting of SR at 0x22[3:0] 1 = The ADC path runs at 24 kHz, and the DAC path at 48 kHz

Ultra-Low Power Stereo Codec

14.9 Configuration Registers

Register address	Bit	Type	Label	Default	Description
0x90 LDO_CTRL	7	R/W	LDO_EN	0	<p>Audio sub-system digital LDO control. The master bias must be enabled for the LDO to operate. 0 = LDO bypassed 1 = LDO active</p> <p>After powering up from Off or from Powerdown Mode, you must wait for a minimum of 40 ms after the first I2C access before enabling the LDO.</p> <p>Failure to wait 40 ms can cause the chip to reset. All other I2C accesses are unaffected.</p>
	6	R/W	(reserved)	0	
	5:4	R/W	LDO_LEVEL_SELECTOR	00	<p>Audio sub-system digital LDO level select: 0 = 1.05 V 1 = 1.10 V 2 = 1.20 V 3 = 1.40 V</p>
	3:0	R/W	(reserved)	0	

Register address	Bit	Type	Label	Default	Description
0x91 IO_CTRL	0	R/W	IO_VOLTAGE_LEVEL	0	<p>Digital I/O voltage range: 0 = 1.2 to 2.8 V 1 = 2.5 to 3.6 V</p>

Ultra-Low Power Stereo Codec

Register address	Bit	Type	Label	Default	Description
0x92 GAIN_RAMP_CTRL	7:2	R/W	(reserved)	000000	
	1:0	R/W	GAIN_RAMP_RATE	00	<p>Speed of the gain-ramping when activated.</p> <p>00 = nominal rate / 8 (ramps from zero to maximum in about 1/128 second)</p> <p>01 = nominal rate / 16 (fastest ramp rate. Ramps from zero to maximum in about 1/256 second)</p> <p>10 = nominal rate * 16 (approximately 1 second fade-in from zero to maximum)</p> <p>11 = nominal rate * 32 (slowest ramp rate, with approximately 2 second fade-in from zero to maximum)</p> <p>The nominal rate is targeted to be approx 1.28 ms per dB for the AUX, HP and LINE, and 0.64 ms per 0.75 dB for the ADC, DAC and MIXOUT</p>

Register address	Bit	Type	Label	Default	Description
0x93 MIC_CONFIG	7	R/W	(reserved)	0	
	6	R/W	(reserved)	0	
	5:4	R/W	(reserved)	00	
	3	R/W	(reserved)	0	
	2	R/W	DMIC_CLK_RATE	0	<p>Clock rate for the digital microphone is:</p> <p>0 = system clock divided by 4 (3.072 MHz or 2.8224 MHz)</p> <p>1 = system clock divided by 8 (1.536 MHz, or 1.4112 MHz)</p>
	1	R/W	DMIC_SAMPLE_PHASE	0	<p>Phase of the digital microphone:</p> <p>0 = sample on DMICCLK edges</p> <p>1 = sample between DMICCLK edges</p>
	0	R/W	DMIC_DATA_SELECT	0	<p>DMIC channel select</p> <p>0 = rising L, falling R</p> <p>1 = falling L, rising R</p>

Ultra-Low Power Stereo Codec

Register address	Bit	Type	Label	Default	Description
0x94 PC_COUNT	7:2	R/W	(reserved)	000000	
	1	R/W	PC_RESYNC_AUTO	1	<p>PC resync mode. If the DAI clock drifts away from the system clock, this determines whether the system attempts to resynchronise the clocks (=1) or whether it skips a sample/samples twice (=0).</p> <p>0 = freerun - double sample if the DAI clock is fast, or skip a sample if the DAI clock is slow 1 = autoresync upon detection of DAI drift with respect to the system clock</p> <p>Resynchronising (PC_RESYNC_AUTO = 1) can reduce the artefacts caused by jitter on either MCLK or BCLK</p>
	0	R/W	PC_FREERUN	0	<p>Enables the filter operation when DAI is not enabled or no DAI clocks are available (ADC to DAC processing path):</p> <p>0 = ADC and DAC Filters synchronised to the DAI 1 = Filters free running</p> <p>This should be set to 1 if the ADC is feeding the DAC directly and no DAI clocks are present</p>

Register address	Bit	Type	Label	Default	Description
0x95 CP_VOL_T HRESHOLD 1	7:6	R/W	(reserved)	00	
	5:0	R/W	CP_THRESH_VDD2	100000	<p>Threshold at and below which the charge pump can use the CPVDD/2 rail. Full details are given in section 13.15</p> <p>This setting is only effective when CP_MCHANGE = 10 or CP_MCHANGE = 11. It is ignored for CP_MCHANGE settings of 00 and 01</p>

Ultra-Low Power Stereo Codec

Register address	Bit	Type	Label	Default	Description
0x96 CP_DELAY	7:6	R/W	CP_ON_OFF	10	Charge pump limiter enable: 00 = limiter on 01 = limiter off 10 = limiter automatically enabled when required 11 = reserved
	5:3	R/W	CP_TAU_DELAY	010	Charge pump voltage decay rate control measured (all values are rounded): 000 = 0 ms 001 = 2 ms 010 = 4 ms 011 = 16 ms 100 = 64 ms 101 = 128 ms 110 = 256 ms 111 = 512 ms
	2:0	R/W	CP_FCONTROL	101	Charge pump nominal clock rate. Lower rates provide lower power but also drive a lower load. If set to 101 (the default), there is no fixed clock frequency. Whenever the HP_POS or HP_NEG voltage is low, the clock runs at 1 MHz and stops as soon as the required voltage is reached. 000 = 1 MHz 001 = 500 kHz 010 = 250 kHz 011 = 125 kHz 100 = 63 kHz 101 = 0 kHz or 1 MHz, depending on demand (analogue mode only) 110 and 111 = reserved

Register address	Bit	Type	Label	Default	Description
0x97 CP_DETECTOR	7:2	R/W	(reserved)	000000	
	1:0	R/W	CPDET_DROP	00	Charge pump maximum voltage droop: 00 = 25 mV 01 = 50 mV 10 = 75 mV 11 = 100 mV

Ultra-Low Power Stereo Codec

Register address	Bit	Type	Label	Default	Description
0x98 DAI_OFFSET	7:0	R/W	DAI_OFFSET	0000000 0	DAI data offset with respect to WCLK. If set to 0, no offset will be inserted relative to the normal formatting. The DAI data offset is measured in BCLK cycles.

Register address	Bit	Type	Label	Default	Description
0x99 DIG_CTRL	7	R/W	DAC_R_INV	0	0 = DAI right input stream is not inverted 1 = DAI right input stream is inverted
	6:4	R/W	(reserved)	000	
	3	R/W	DAC_L_INV	0	0 = DAI left input stream is not inverted 1 = DAI left input stream is inverted
	2:0	R/W	(reserved)	000	

Register address	Bit	Type	Label	Default	Description
0x9A ALC_CTRL2	7:4	R/W	ALC_RELEASE	0000	<p>Sets the ALC release rate. This is the speed at which the ALC can increase the gain by 1 dB.</p> <p>0000 = 29/fs (0.6 ms/dB @48 kHz) 0001 = 57/fs (1.2 ms/dB @48 kHz) 0010 = 115/fs (2.4 ms/dB @48 kHz) 0011 = 229/fs (4.8 ms/dB @48 kHz) 0100 = 459/fs (9.6 ms/dB @48 kHz) 0101 = 917/fs (19.1 ms/dB @48 kHz) 0110 = 1834/fs (38.2 ms/dB @48 kHz) 0111 = 3669/fs (76.4 ms/dB @48 kHz) 1000 = 7338/fs (153 ms/dB @48 kHz) 1001 = 14676/fs (306 ms/dB @48 kHz) 1010 to 11111 = 29347/fs (611 ms/dB @48 kHz)</p>
	3:0	R/W	ALC_ATTACK	0000	<p>Sets the ALC attack rate, which is the speed at which the ALC can decrease the gain by 1 dB.</p> <p>0000 = 7.3/fs (0.15 ms/dB @48 kHz) 0011 = 15/fs (0.31 ms/dB @48 kHz) 0010 = 29/fs (0.61 ms/dB @48 kHz) 0011 = 59/fs (1.2 ms/dB @48 kHz) 0100 = 117/fs (2.4 ms/dB @48 kHz) 0101 = 235/fs (4.9 ms/dB @48 kHz) 0110 = 469/fs (9.8 ms/dB @48 kHz) 0111 = 938/fs (20 ms/dB @48 kHz) 1000 = 1876/fs (39 ms/dB @48 kHz) 1001 = 3753/fs (78 ms/dB @48 kHz) 1010 = 7506/fs (156 ms/dB @48 kHz) 1011 = 15012/fs (312 ms/dB @48 kHz) 1100 to 1111 = 30024/fs (625 ms/dB @48 kHz)</p>

Ultra-Low Power Stereo Codec

Register address	Bit	Type	Label	Default	Description
0x9B ALC_CTRL3	7:6	R/W	ALC_INTEG_RELEASE	00	Sets the rate at which the input signal envelope is tracked as the signal gets smaller 00 = 1/4 01 = 1/16 10 = 1/256 11 = Reserved (Do not use)
	5:4	R/W	ALC_INTEG_ATTACK	00	Sets the rate at which the input signal envelope is tracked as the signal gets larger: 00 = 1/4 01 = 1/16 10 = 1/256 11 = Reserved (Do not use)
	3:0	R/W	ALC_HOLD	0000	Sets the ALC hold time, which is the the length of time that the ALC waits before releasing 0000 = 62/fs (1.3 ms @48 kHz) 0001 = 124/fs (2.6 ms @48 kHz) 0010 = 248/fs (5.2 ms @48 kHz) 0011 = 496/fs (10.3 ms @48 kHz) 0100 = 992/fs (20.7 ms @48 kHz) 0101 = 1984/fs (41.3 ms @48 kHz) 0110 = 3968/fs (82.7 ms @48 kHz) 0111 = 7936/fs (165 ms @48 kHz) 1000 = 15872/fs (331 ms @48 kHz) 1001 = 31744/fs (661 ms @48 kHz) 1010 = 63488/fs (1.3 s @48 kHz) 1011 = 126976/fs (2.6 s @48 kHz) 1100 = 253952/fs (5.3 s @48 kHz) 1101 = 507904/fs (10.6 s @48 kHz) 1110 = 1015808/fs (21 s @48 kHz) 1111 = 2031616/fs (42 s @48 kHz)

Register address	Bit	Type	Label	Default	Description
0x9C ALC_NOISE	7:6	R/W	(reserved)	00	
	5:0	R/W	ALC_NOISE	111111	Sets the threshold below which input signals will not cause the ALC to change gain: 000000 = 0 dBFS 000001 = -1.5 dBFS continuing in -1.5 dBFS steps to 111111 = -94.5 dBFS

Ultra-Low Power Stereo Codec

Register address	Bit	Type	Label	Default	Description
0x9D ALC_TARGET_MIN	7:6	R/W	(reserved)	00	
	5:0	R/W	ALC_THRESHOLD_MIN	111111	<p>Sets the minimum amplitude of the ALC output signal before the ALC increases the gain. If the maximum allowable gain level is reached then the ALC will not increase the gain even if this threshold is breached:</p> <p>000000 = 0 dBFS 000001 = -1.5 dBFS</p> <p>continuing in -1.5 dBFS steps to</p> <p>111111 = -94.5 dBFS</p>

Register address	Bit	Type	Label	Default	Description
0x9E ALC_TARGET_MAX	7:6	R/W	(reserved)	00	
	5:0	R/W	ALC_THRESHOLD_MAX	000000	<p>Sets the maximum amplitude of the ALC output signal before the ALC decreases the gain. If the maximum attenuation level allowed is reached then the ALC will not reduce the gain even if this threshold is exceeded:</p> <p>000000 = 0 dBFS 000001 = -1.5 dBFS</p> <p>continuing in -1.5 dB steps to</p> <p>111111 = -94.5 dBFS</p>

Register address	Bit	Type	Label	Default	Description
0x9F ALC_GAIN_LIMITS	7:4	R/W	ALC_GAIN_MAX	1111	<p>Sets the maximum amount of gain that can be applied to the input signal by the ALC when the input signal amplitude is smaller than ALC_THRESHOLD_MIN:</p> <p>0000 = 0 dB 0001 = 6 dB</p> <p>continuing in +6 dB steps to</p> <p>1111 = 90 dB</p>
	3:0	R/W	ALC_ATTEN_MAX	1111	<p>Sets the maximum amount of attenuation that can be applied to the input signal by the ALC when the input signal amplitude is larger than ALC_THRESHOLD_MAX:</p> <p>0000 = 0 dB 0001 = 6 dB</p> <p>continuing in +6 dB steps to</p> <p>1111 = 90 dB</p>

Ultra-Low Power Stereo Codec

Register address	Bit	Type	Label	Default	Description
0xA0 ALC_ANA_GAIN_LIMITS	7	R/W	(reserved)	0	
	6:4	R/W	ALC_ANA_GAIN_MAX	111	<p>Sets the maximum amount of analogue gain that can be applied to the input signal by the ALC when the input signal amplitude is smaller than ALC_THRESHOLD_MIN:</p> <p>000 = reserved 001 = 0 dB 010 = 6 dB</p> <p>continuing in +6 dB steps to</p> <p>111 = 36 dB</p>
	3	R/W	(reserved)	0	
	2:0	R/W	ALC_ANA_GAIN_MIN	001	<p>Sets the minimum amount of analogue gain that can be applied to the input signal by the ALC when the input signal amplitude is larger than ALC_THRESHOLD_MAX:</p> <p>000 = reserved 001 = 0 dB 010 = 6 dB</p> <p>continuing in +6 dB steps to</p> <p>111 = 36 dB</p>

Register address	Bit	Type	Label	Default	Description
0xA1 ALC_ANTICLIP_CTRL	7	R/W	ALC_ANTICLIP_EN	0	<p>Enables the ALC signal clip prevention mechanism:</p> <p>0 = Disabled 1 = Enabled</p>
	6:2	R/W	(reserved)	00000	
	1:0	R/W	(reserved)	00	

Ultra-Low Power Stereo Codec

Register address	Bit	Type	Label	Default	Description
0xA2 ALC_ANTICLIP_LEVEL	7	R/W	(reserved)	0	
	6:0	R/W	ALC_ANTICLIP_LEVEL	0000000	Sets the threshold above which the ALC enters anti-clip operation. The formula for determining the anti-clip level is: $(\text{ALC_ANTICLIP_LEVEL}+1)*\text{Full Scale}/128$ 0000000 = 0.0078*Full Scale 0000001 = 0.015*Full Scale continuing in 0.0078 steps to 1111111 = 1.0000*Full Scale

Register address	Bit	Type	Label	Default	Description
0xAF DAC_NG_SETUP_TIME	7:4	R/W	(reserved)	0000	
	3	R/W	DAC_NG_RAMP_DN_RATE	0	Attack rate at which the gain of the output amplifier (HP or LINE) is reduced: 0 = 0.64 ms/dB 1 = 20.48 ms/dB
	2	R/W	DAC_NG_RAMP_UP_RATE	0	Release rate at which the gain of the output amplifier (HP or LINE) is increased: 0 = 0.02 ms/dB 1 = 0.16 ms/dB
	1:0	R/W	DAC_NG_SETUP_TIME	00	Time for which the largest signal through the DACs must be below DAC_NG_ON_THRESHOLD for the noise-gate to mute the data: 00 = 256 samples 01 = 512 samples 10 = 1024 samples 11 = 2048 samples

Register address	Bit	Type	Label	Default	Description
0xB0 DAC_NG_OFF_THRESHOLD	7:3	R/W	(reserved)	00000	
	2:0	R/W	DAC_NG_OFF_THRESHOLD	000	Threshold above which the noise-gate will be deactivated: 000 = -90 dB 001 = -84 dB ... 111 = -48 dB

Ultra-Low Power Stereo Codec

Register address	Bit	Type	Label	Default	Description
0xB1 DAC_NG_ON_THRESHOLD	7:3	R/W	(reserved)	00000	
	2:0	R/W	DAC_NG_ON_THRESHOLD	000	Threshold below which the noise-gate starts to activate: 000 = -90 dB 001 = -84 dB ... 111 = -48 dB

Register address	Bit	Type	Label	Default	Description
0xB2 DAC_NG_CTRL	7	R/W	DAC_NG_EN	0	DAC noise-gate enable: 0 = disabled 1 = enabled
	6:0	R/W	(reserved)	0000000	

Register address	Bit	Type	Label	Default	Description
0xB4 TONE_GEN_CFG1	7	R/W	START_STOPN	0	Tone generator stop and start control. Setting this to high will start the tone-generator. After the tone-generator has finished it will reset the register to 0. In Continuous mode, setting it to 0 will stop the tone generation.
	6:5	R/W	(reserved)	00	
	4	R/W	DMTF_EN	0	DTMF enable 0 = Use values in the FREQ1 and FREQ2 registers to generate sine wave(s) 1 = Use values from the DMTF_REG to generate sine-waves
	3:0	R/W	DMTF_REG	0000	The DTMF keypad values 0 to 15.

Ultra-Low Power Stereo Codec

Register address	Bit	Type	Label	Default	Description
0xB5 TONE_GEN_CFG2	7:4	R/W	GAIN	0000	0000 = 0 dB 0001 = -3 dB 0010 = -6 dB 0011 = -9 dB continuing in -3 dB steps to 1111 = -45 dB
	3:2	R/W	(reserved)	00	
	1:0	R/W	SWG_SEL	00	Sine wave select: 00 = Sum of both SWG values is mixed into the audio 01 = Only SWG1 value is output 10 = Only SWG2 value is output 11 = Sum of both SWG values is mixed into the audio.

Register address	Bit	Type	Label	Default	Description
0xB6 TONE_GEN_CYCLES	7:3	R/W	(reserved)	00000	
	2:0	R/W	BEEP_CYCLES	000	Number of beep cycles required. 000 = 1 cycle 001 = 2 cycles 010 = 4 cycles 011 = 8 cycles 100 = 16 cycles 101 = 32 cycles 110 and 111 = infinite (until START_STOPN is set to 0)

Register address	Bit	Type	Label	Default	Description
0xB7 TONE_GEN_FREQ1_L	7:0	R/W	FREQ1_L	0x55	Lower two bytes of the four-byte number used to calculate the output frequency for the first Sine Wave Generator (SWG1). The output frequency is dependent on the sample rate For sample rates (SR) = 8/12/16/24/32/48/96 kHz: $FREQ1_U \& FREQ1_L = (2^{16} * (f_{Hz}/12000)) - 1$ For sample rates (SR) = 11.025/22.05/44.4/88.2 kHz: $FREQ1_U \& FREQ1_L = (2^{16} * (f_{Hz}/11025)) - 1$

Ultra-Low Power Stereo Codec

Register address	Bit	Type	Label	Default	Description
0xB8 TONE_GEN _FREQ1_U	7:0	R/W	FREQ1_U	0x15	Upper two bytes of the four-byte number used to calculate the output frequency for the first Sine Wave Generator (SWG1). The output frequency is dependent on the sample rate For sample rates (SR) = 8/12/16/24/32/48/96 kHz: FREQ1_U & FREQ1_L = $(2^{16} * (f_{Hz}/12000)) - 1$ For sample rates (SR) = 11.025/22.05/44.4/88.2 kHz: FREQ1_U & FREQ1_L = $(2^{16} * (f_{Hz}/11025)) - 1$

Register address	Bit	Type	Label	Default	Description
0xB9 TONE_GEN _FREQ2_L	7:0	R/W	FREQ2_L	0x00	Lower two bytes of the four-byte number used to calculate the output frequency for the second Sine Wave Generator (SWG2). The output frequency is dependent on the sample rate For sample rates (SR) = 8/12/16/24/32/48/96 kHz: FREQ2_U & FREQ2_L = $(2^{16} * (f_{Hz}/12000)) - 1$ For sample rates (SR) = 11.025/22.05/44.4/88.2 kHz: FREQ2_U & FREQ2_L = $(2^{16} * (f_{Hz}/11025)) - 1$

Register address	Bit	Type	Label	Default	Description
0xBA TONE_GEN _FREQ2_U	7:0	R/W	FREQ2_U	0x40	Upper two bytes of the four-byte number used to calculate the output frequency for the second Sine Wave Generator (SWG2). The output frequency is dependent on the sample rate For sample rates (SR) = 8/12/16/24/32/48/96 kHz: FREQ2_U & FREQ2_L = $(2^{16} * (f_{Hz}/12000)) - 1$ For sample rates (SR) = 11.025/22.05/44.4/88.2 kHz: FREQ2_U & FREQ2_L = $(2^{16} * (f_{Hz}/11025)) - 1$

Ultra-Low Power Stereo Codec

Register address	Bit	Type	Label	Default	Description
0xBB TONE_GEN _ON_PER	7:6	R/W	(reserved)	00	Beep cycle on-period control 00 0001 = 10 ms 00 0010 = 20 ms 00 0011 = 30 ms continuing in 10 ms steps to... 01 0100 = 200ms then... 01 0101 to 01 1000 = reserved then... 01 1001 = 250 ms 01 1010 = 300 ms and continuing in 50 ms steps to... 11 1100 = 2000 ms 11 1101 = reserved 11 1110 = reserved 11 1111 = continuous
	5:0	R/W	BEEP_ON_PER	000010	

Ultra-Low Power Stereo Codec

Register address	Bit	Type	Label	Default	Description
0xBC TONE_GEN _OFF_PER	7:6	R/W	(reserved)	00	
	5:0	R/W	BEEP_OFF_P E R	000001	<p>Beep cycle off-period control</p> <p>00 0001 = 10 ms 00 0010 = 20 ms 00 0011 = 30 ms</p> <p>continuing in 10 ms steps to... 01 0100 = 200ms</p> <p>then... 01 0101 to 01 1000 = reserved</p> <p>then... 01 1001 = 250 ms 01 1010 = 300 ms and continuing in 50 ms steps to...</p> <p>11 1100 = 2000 ms</p> <p>11 1101 = reserved 11 1110 = reserved 11 1111 = continuous</p>

Register address	Bit	Type	Label	Default	Description
0xE0 SYSTEM_S TATUS	7:2	R/W	(reserved)	000000	
	1	RO	SC2_BUSY	0	<p>Indicates the current status of System Controller 2</p> <p>0 = complete 1 = busy</p>
	0	RO	SC1_BUSY	0	<p>Indicates the current status of System Controller 1</p> <p>0 = complete 1 = busy</p>

Register address	Bit	Type	Label	Default	Description
0xFD SYSTEM_A CTIVE	7:1	R/W	(reserved)	0000000	
	0	R/W	SYSTEM_ACTI V E	0	<p>Switch off the oscillator</p> <p>0 = oscillator off 1 = oscillator on</p>

15 Package Information

15.1 Package Outlines

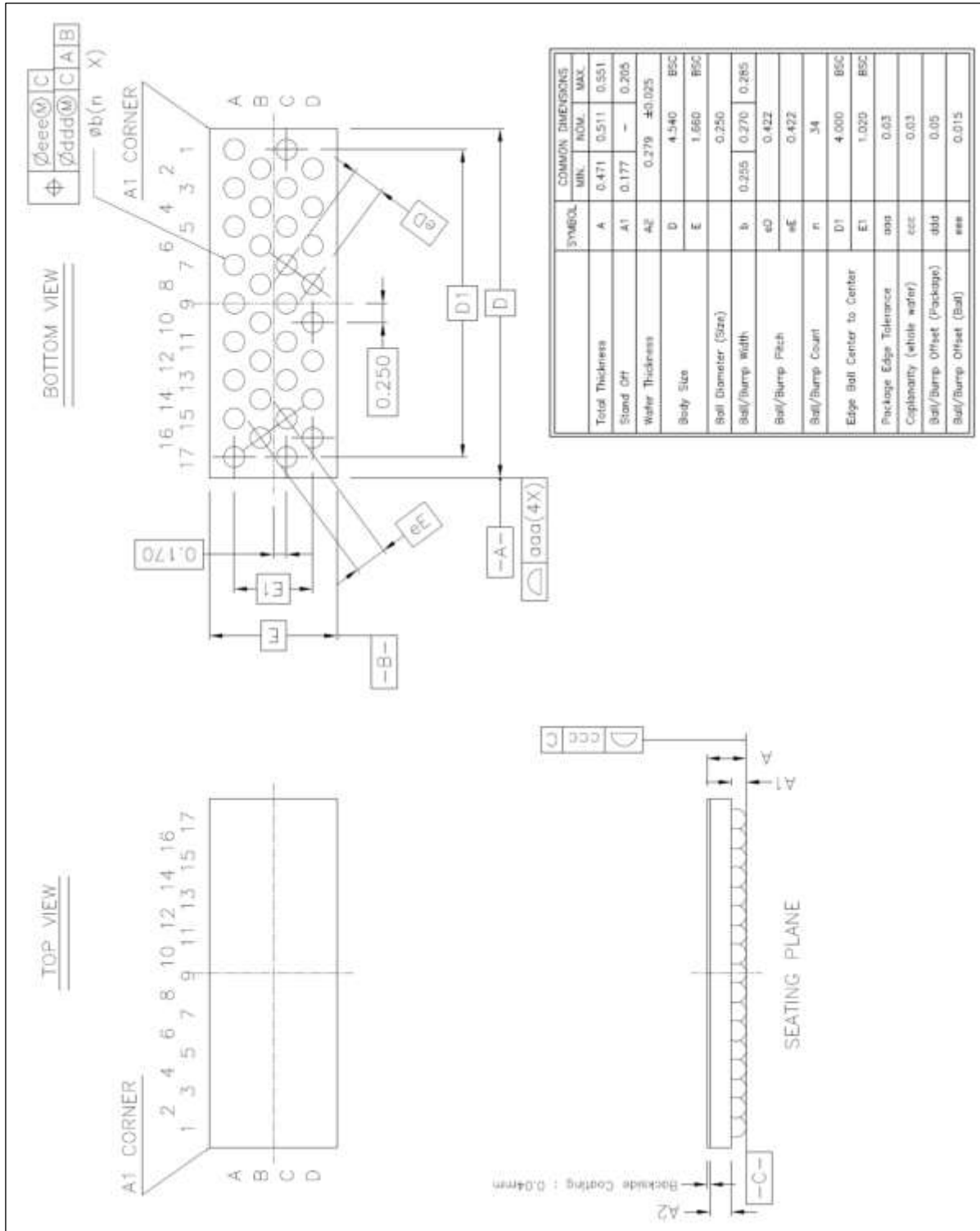

Figure 35: DA7212 package outline drawing

15.2 Soldering Information

Refer to the JEDEC standard J-STD-020 for relevant soldering information. This document can be downloaded from <http://www.jedec.org>.

16 Ordering Information

The ordering number consists of the part number followed by a suffix indicating the packing method. For details and availability, please contact Dialog Semiconductor's local sales representative.

Table 37: Ordering information

Part number	Package	Shipment form	Pack quantity
DA7212-01UM2	34-bump CSP Pb free/green	Tape and Reel	4500
DA7212-01UM6	34-bump CSP Pb free/green	Tray/Waffle Pack (engineering samples only - not for mass production)	98

Appendix A Applications Information

A.1 Codec Initialisation

Depending on the specific application, some general settings need to be set. Examples of these settings include the sample rate, the PLL, and the digital audio interface. Then the amplifiers, the mixers and channels of the ADC/DAC have to be configured and enabled via their respective control registers.

An example sequence is shown below:

1. Configure clock mode as required for operation, (e.g. PLL bypass / PLL etc...)
2. Configure the digital audio interface
3. Configure the charge pump if the headphone path is in use.
4. Set input and output mixer paths and gains
5. Enable input and output paths using the Level 2 system controller (SLC2)

A.2 Automatic ALC Calibration

When using the automatic level control (ALC) in sync-mode the DC offset between the digital and analogue PGAs must be cancelled. This is performed automatically if the following procedure is performed:

1. Setup device clocks and references.
2. Configure ALC parameters.
3. Enable microphone amplifiers (unmuted).
4. Mute microphones.
5. Enable input mixer and route the microphone to the mixers.
6. Enable ADC (muted).
7. Set ALC_AUTO_CALIB_EN in ALC_CTRL1 to 1 (ALC_CTRL1 = 0x10). This bit will auto-clear when calibration is complete.
8. When calibration is complete, enable the ALC with ALC_SYNC_MODE and ALC_OFFSET_EN enabled (ALC_CTRL1 = 0x8B).
9. Unmute microphones and ADCs.

The calibration routine requires the full signal path from microphone to ADC to be enabled and a clock to be present. The calibration routine using MIC1_P and MIC2_P and with the device in slave mode is outlined in Table 38.

Table 38: Offset calibration, MIC1_P and MIC2_P single ended, slave mode

Instructions	Registers affected	Value
Enable Master Bias	0x23	0x80
Enable DAI and setup clocks (for 44.1 kHz, I2S, slave mode)	0x29	0xC8
Configure ALC parameters as application requires		
Enable the Microphones unmuted	0x63 0x64	0x84 0x84
Mute the microphones	0x63 0x64	0xC4 0xC4
Enable the Input mixers unmuted	0x65 0x66	0xA8 0xA8
Route the microphone to the mixers	0x32 0x33	0x04 0x04
Enable the ADC muted	0x67 0x68	0xF0 0xF0
Calibrate Offset	0x2B	0x10
Wait until offset bit has been cleared	Wait until 0x2B = 0x00	
Enable ALC	0x2B	0x8B
Unmute Microphones and ADC	0x63 0x64 0x67 0x68	0xA8 0xA8 0xA0 0xA0

Other clocking and microphone setups are also possible by changing their respective registers. Once this calibration is complete the record path with Automatic Level Control is active.

A.3 Troubleshooting

0x2B should automatically clear after 256 samples (5.33ms at 48 kHz). If 0x2B does not return 0x00 after 256 samples this indicates a setup error. If this occurs check that the microphone is enabled and muted, the mixer is enabled with the microphone input selected and unmuted and that the ADC is enabled and unmuted. It is also critical that an MCLK and BCLK are present on the device. BCLK can be provided either from the AIF interface in slave mode or generated internally by having the device in master mode.

Appendix B Components

The following recommended components are examples selected from requirements of a typical application. The electrical characteristics (that is, the supported voltage/current ranges) have to be cross-checked and component types may need to be adapted from the individual needs of the target circuitry.

B.1 Audio Inputs

Table 39: Audio inputs

Pin Name	Bump/Pin	Power Domain	Description	Type
MIC1_P	C17	VDD_A	Differential mic. input 1 (positive) / Single-ended mic. Input 1 (left)	Analogue Input
MIC1_N	B16	VDD_A	Differential mic. input 1 (negative) / Single-ended mic. Input 2 (left)	Analogue Input
MIC2_P	D16	VDD_A	Differential mic. input 2 (positive) / Single-ended mic. Input 1 (right)	Analogue Input
MIC2_N	C15	VDD_A	Differential mic. input 2 (negative) / Single-ended mic. Input 2 (right)	Analogue Input
AUX_L	C13	VDD_A	Single-ended auxiliary input (left)	Analogue Input
AUX_R	D14	VDD_A	Single-ended auxiliary input (right)	Analogue Input

The DA7212 microphone inputs can be configured to accommodate single-ended or differential microphones and line inputs. These are accompanied by two dedicated single ended auxiliary input pins.

The internal input mixer allows all inputs to be mixed prior to the ADC. Analogue bypass paths exist directly from the AUX inputs to the output mixers and from the input mixer to the output mixer should the ADC not be required.

A DC blocking capacitor is required for each used analogue input bump used in the target application. The choice of capacitor is determined by the filter that is formed between that capacitor and the input impedance of the input pin which can be found in the 'Input Mixing Units' section of the datasheet.

$$C = \frac{1}{2\pi \cdot R \cdot F_c}$$

Where F_c is the 3 dB cut off frequency of the low pass filter (typically 20 Hz for audio applications). A 1 μ F capacitor is suitable for most applications.

Due to their high stability tantalum capacitors are particularly suitable for this application. Ceramic equivalents with an X5R dielectric are recommended as a cost effective alternative. Care should be taken to ensure that the desired capacitance is maintained over operating temperature and voltage.

Z5U dielectric ceramics should be avoided due to their susceptibility to microphonic effects.

Unused input bumps can be left floating or connected via a capacitor to ground.

B.2 Microphone Bias

Table 40: Microphone bias

Pin Name	Bump/Pin	Power Domain	Description	Type
MICBIAS1	A15	VDD_MIC	Microphone bias output 1	Analogue Output
MICBIAS2	A17	VDD_MIC	Microphone bias output 2	Analogue Output

A 1 μ F capacitor to GND_A should be used to decouple the MICBIAS output.

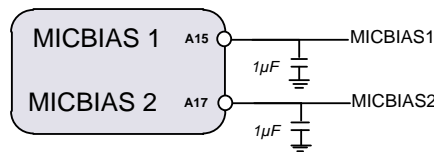

Figure 36: MICBIAS decoupling

B.3 Digital Microphone

Table 41: Digital microphones

Pin Name	Bump/Pin	Power Domain	Description	Type
DMICCLK	C17	VDD_MIC	Digital Microphone Clock	Digital Output
DMICIN	B16	VDD_MIC	Digital Microphone Data	Digital Input

These pins can be routed directly to a digital microphone. In stereo mode they can be connected to two digital microphones with one configured to send data on the rising clock edge and the other on the falling edge. The clock output operates at 1.5 MHz or 3 MHz. The appropriate layout considerations for clock signals should be followed.

B.4 Audio Outputs

Table 42: Headphone outputs

Pin Name	Bump/Pin	Power Domain	Description	Type
HP_L	A3	VDD_A	True-ground headphone output (left)	Analogue Output
HP_R	A5	VDD_A	True-ground headphone output (right)	Analogue Output
GND_SENSE	B4	VDD_A	Ground reference for headphone output	Analogue Input

DA7212 contains a capless true-ground Class-G headphone amplifier with a ground sense connection. For optimum noise immunity the headphone ground sense should be tracked between the HP_L and HP_R signals before being grounded at the headphone connector. In this configuration the ground sense connector cancels common mode noise on the headphone from the PCB.

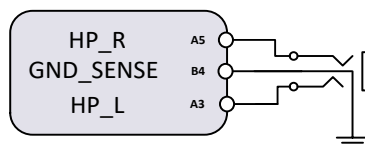

Figure 37: Recommended headphone layout

Table 43: Speaker outputs

Pin Name	Bump/Pin	Power Domain	Description	Type
SP_P	B12	VDD_SP	Differential speaker output (pos)	Analogue Output
SP_N	A13	VDD_SP	Differential speaker output (neg)	Analogue Output

The DA7212 has a differential Class-AB speaker driver that can output 1.2 W into an 8 ohm speaker. These pins can be connected directly to an external speaker or receiver or as a differential line output. For common mode noise immunity SP_P and SP_N should be treated as a differential pair where possible.

A DC blocking capacitor is required when the speaker is being used to drive a line level output. The choice of capacitor is determined by the filter that is formed between that capacitor and the impedance of the load.

$$C = \frac{1}{2\pi \cdot R \cdot F_c}$$

Where F_c is the 3 dB cut off frequency of the low pass filter (typically 20 Hz for audio applications). A 1 μ F capacitor is suitable for most applications.

Due to their high stability tantalum capacitors are particularly suitable for this application. Ceramic equivalents with an X5R dielectric are recommended as a cost effective alternative. Care should be taken to ensure that the desired capacitance is maintained over operating temperature and voltage. If the speaker/line output is unused the output pins can be left floating or connected via a capacitor to ground.

B.5 Headphone Charge Pump

Table 44: Headphone charge pump

Pin Name	Bump/Pin	Power Domain	Description	Type
HPCSP	A1	VDD_A	Chargepump reservoir capacitor (pos)	Charge Pump
HPCSN	C1	VDD_A	Chargepump reservoir capacitor (neg)	Charge Pump
HPCFP	D2	VDD_A	Chargepump flying capacitor (pos)	Charge Pump
HPCFN	C3	VDD_A	Chargepump flying capacitor (neg)	Charge Pump

A 1 μ F reservoir capacitor is required between the HPCSP and GND_CP and between HPCSN and GND_CP. For best performance the capacitors should be fitted as near to the device as possible.

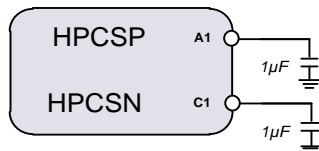

Figure 38: Charge pump decoupling

A 1 μ F flying capacitor is required between HPCFP and HPCFN. For best performance the capacitor should be fitted as near to the device as possible.



Figure 39: Charge pump flying capacitor

To ensure stable charge pump operation the effective series resistance of the flying capacitor should be kept to a minimum. This can be achieved by selecting an appropriate capacitor dielectric (X5R, X7R) and ensuring that the capacitor is placed as near to the device as possible. Ideally the connection between the pins and the capacitor should not run through Vias (connected on top layer of PCB only).

B.6 Digital Interfaces

Table 45: Digital interfaces - I2C

Pin Name	Bump/Pin	Power Domain	Description	Type
SDA	C9	VDD_IO	I2C bi-directional data	Digital Input / Output
SCL	D8	VDD_IO	I2C clock input	Digital Input

The I2C data and clock lines are powered from VDD_IO. Both I2C line require a pull up to VDD_IO. The value of this pull up is dependent on I2C bus speed, bus length and supply voltage. A 2.2 kΩ resistor is satisfactory in most applications.

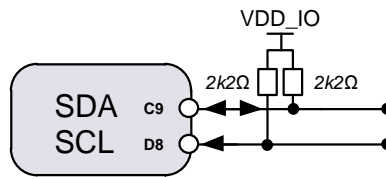

Figure 40: I2C pull ups

Table 46: Digital interfaces - I2S

Pin name	Bump/pin	Power domain	Description	Type
DATIN	C5	VDD_IO	DAI data input	Digital Input
DATOUT	C7	VDD_IO	DAI data output	Digital Output
BCLK	D4	VDD_IO	DAI bit clock	Digital Input / Output
WCLK	D6	VDD_IO	DAI word clock (L/R select)	Digital Input / Output
MCLK	C11	VDD_IO	Master clock	Digital Input

The DAI interface pins should be treated as clock signals and the appropriate layout rules for routing clocks should be adhered to.

B.7 References

Table 47: References

Pin name	Bump/pin	Power domain	Description	Type
DACREF	A7	VDD_A	Audio DAC reference capacitor	Reference
VMID	A9	VDD_A	Audio mid-rail reference capacitor	Reference
VREF	B8	VDD_A	Bandgap reference capacitor	Reference

A 1 μ F capacitor should be connected between each of the references and GND_A. For best performance the capacitors should be fitted as near to the device as possible.

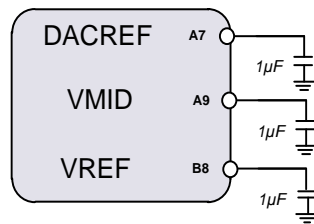

Figure 41: Reference capacitors

B.8 Supplies

Table 48: Power supplies

Pin name	Bump/pin	Power domain	Description	Type
VDD_A	B6	Min: 1.7 V Max: 2.5 V	Supply for analogue circuits / Supply for headphone charge pump	Power Supply
VDD_IO	D10	Min: 1.6 V Max: 3.6 V	Supply for digital interfaces	Power Supply
VDD_SP	A11	Min: 0.95 V Max: 5.25 V	Supply for speaker driver	Power Supply
VDD_MIC	B14	Min: 1.8 V Max: 3.6 V	Supply for microphone bias circuits	Power Supply
VDIG	D12		Output of internal regulator.	Power Supply

Decoupling capacitors are recommended between all supplies and GND_A. These capacitors should be located as near to the device as possible.

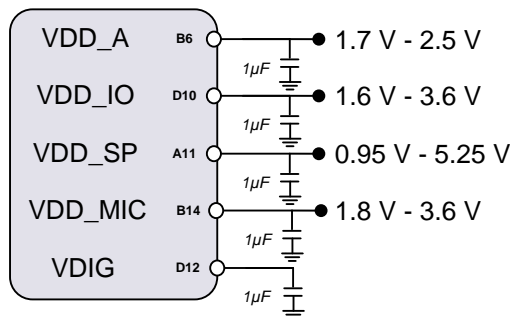

Figure 42: Power supply decoupling

B.9 Ground

Table 49: Ground

Pin name	Bump/pin	Power domain	Description	Type
GND_A	B10		Analogue ground	Power Ground
GND_CP	B2		Digital/chargepump ground	Power Ground

GND_A and GND_CP should be connected directly to the system ground.

B.10 Capacitor Selection

Ceramic capacitors are manufactured with a variety of dielectrics, each with a different behaviour over temperature and applied voltage. Capacitors must have a dielectric adequate to ensure the minimum capacitance over the necessary temperature range, dc bias conditions and low Equivalent Series Resistance (ESR). X5R or X7R dielectrics with a voltage rating of 6.3 V or 10 V are recommended for best performance. Y5V and Z5U dielectrics are not recommended for use because of their poor temperature and dc bias characteristics.

The worst-case capacitance accounting for capacitor variation over temperature, component tolerance, and voltage is calculated using the following equation:

$$C_{EFF} = C_{OUT} \times (1 - TEMP_{CO}) \times (1 - TOL)$$

where: *CEFF* is the effective capacitance at the operating voltage. *TEMP_{CO}* is the worst-case capacitor temperature coefficient. *TOL* is the worst-case component tolerance. These figures can be found in the manufacturer’s datasheet.

In the example below, the worst-case temperature coefficient (*TEMP_{CO}*) over -55°C to +85°C is assumed to be 15 %. The tolerance of the capacitor (*TOL*) is assumed to be 10 %, and *C_{OUT}* is 0.65 µF at 1.8 V.

Substituting these values in the equation yields

$$C_{EFF} = 0.65 \mu F \times (1 - 0.15) \times (1 - 0.1) = 0.497 \mu F$$

Table 50: Recommended capacitor types

Application	Value	Size	Temp. char.	Tolerance	Rated voltage	Type
VDD_IO, VREF, VDD_MIC, VDD_SP, VDD_A, VDIG, DACREF, VMID, HPCFP/HPCFN, HPCSP, HPCSN, MICBIAS1, MICBIAS2, AUX_L, AUX_R	14 x 1 µF	0201	X5R +/- 15 %	+/-10 %	6.3 V	Murata GRM033R60J105M

Appendix C PCB Layout Guidelines

DA7212 uses Dialog Semiconductor’s ‘Route Easy™’ technology allowing the device to be routed using conventional, low cost, PCB technology. All device balls are routable on the top level and conventional plated through hole vias can be used throughout.

This design is fully realisable using a 2-layer PCB however for optimum performance it is recommended that a 4-layer PCB is used with layers 2 and 3 as solid ground planes.

Decoupling and reference capacitors should be located as close to the device as possible and appropriately sized tracks should be used for all power connections.

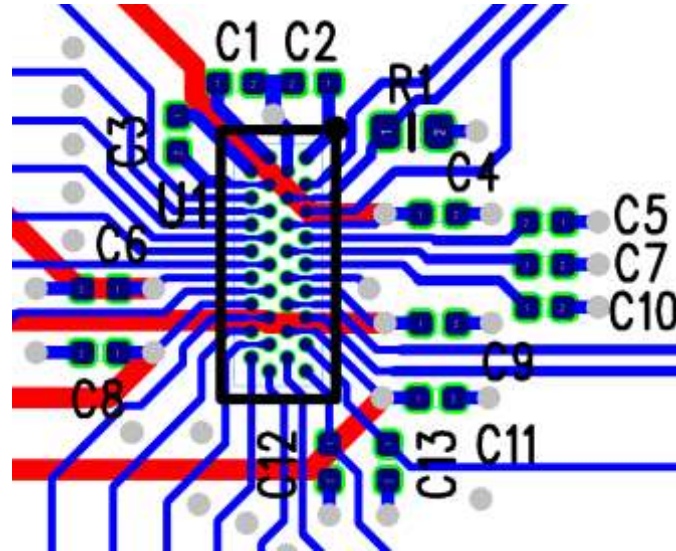

Figure 43: Example layout

C.1 Layout and Schematic Support

Copies of the evaluation board schematics and layout are available on request to aid in PCB development. Dialog Semiconductor also offer a schematic and layout review service for all designs utilising Dialog’s devices. Please contact your local Dialog Semiconductor Office if you wish to utilise this service.

C.2 General Recommendations

- Appropriate trace width and number of vias should be used for all power supply paths
- A common ground plane should be used, which allows proper electrical and thermal performance
- Noise-sensitive analogue signals such as feedback lines or clock connections should be kept away from traces carrying pulsed analogue or digital signals. This can be achieved by separation (distance) or by shielding with quiet signals or ground traces
- Decoupling capacitors should be X5R ceramics and should be placed as near to the device as possible
- Charge pump capacitors should be X5R ceramics and should be placed as near to the device as possible

Revision History

Revision	Date	Description
1.0	2013	Initial version.
3c	24-11-2015	Update to latest template. Outstanding jira issues raised against previous datasheet resolved. Removal of Word template reference number from footer.
3.4	31-Aug-2017	<ul style="list-style-type: none"> ● Section 6: Electrical characteristics <ul style="list-style-type: none"> ○ Table 5: Power consumption <ul style="list-style-type: none"> – Changed Min table column heading to Typ. ● Section 13.4: Digital microphones <ul style="list-style-type: none"> ○ Removed text “Modulators up to 3rd Order are supported” ○ Corrected 1.5 Mhz and 3 MHz clock rates to 3.072 MHz or 2.8224 MHz, or 1.536 MHz or 1.4112 MHz ● Section 13.26.1: Normal PLL mode (DAI master) <ul style="list-style-type: none"> ○ Correction to text was “...to reduce the PLL reference frequency to the usable range of 2 to 50 MHz...” now “...to reduce the PLL reference frequency to the usable range of 2 to 5 MHz...” ○ Correction to equation was “$FREF = FMCLK \div (2^{PLL_INDIV})$” now “$FREF = FMCLK \div (2^{PLL_INDIV+1})$” ● Section 13.40.1: Entering standby mode <ul style="list-style-type: none"> ○ Added line “When using the line/speaker output the amplifier must be disabled prior to entering standby mode”. ● Section 14.9: Configuration registers <ul style="list-style-type: none"> ○ Added register 0x91 IO_CTRL ○ Register 0x93 MIC_CONFIG <ul style="list-style-type: none"> – Corrected DMIC_CLK_RATE description ● Appendix A2: ALC Calibration <ul style="list-style-type: none"> ○ Clarified calibration routine in text and in Table 38. ● Appendix B6: Digital Interfaces <ul style="list-style-type: none"> ○ Table 46: Digital interfaces - I2S <ul style="list-style-type: none"> – Corrected DATIN and DATOUT pin types
3.5	04-Jan-2022	<ul style="list-style-type: none"> ● Rebranded to Renesas, no change of contents

Ultra-Low Power Stereo Codec

Status Definitions

Revision	Datasheet status	Product status	Definition
1.<n>	Target	Development	This datasheet contains the design specifications for product development. Specifications may be changed in any manner without notice.
2.<n>	Preliminary	Qualification	This datasheet contains the specifications and preliminary characterisation data for products in pre-production. Specifications may be changed at any time without notice in order to improve the design.
3.<n>	Final	Production	This datasheet contains the final specifications for products in volume production. The specifications may be changed at any time in order to improve the design, manufacturing and supply. Relevant changes will be communicated via Customer Product Notifications.
4.<n>	Obsolete	Archived	This datasheet contains the specifications for discontinued products. The information is provided for reference only.

RoHS Compliance

Dialog Semiconductor complies to European Directive 2001/95/EC and from 2 January 2013 onwards to European Directive 2011/65/EU concerning Restriction of Hazardous Substances (RoHS/RoHS2). Dialog Semiconductor's statement on RoHS can be found on the customer portal <https://support.diasemi.com/>. RoHS certificates from our suppliers are available on request.

IMPORTANT NOTICE AND DISCLAIMER

RENESAS ELECTRONICS CORPORATION AND ITS SUBSIDIARIES (“RENESAS”) PROVIDES TECHNICAL SPECIFICATIONS AND RELIABILITY DATA (INCLUDING DATASHEETS), DESIGN RESOURCES (INCLUDING REFERENCE DESIGNS), APPLICATION OR OTHER DESIGN ADVICE, WEB TOOLS, SAFETY INFORMATION, AND OTHER RESOURCES “AS IS” AND WITH ALL FAULTS, AND DISCLAIMS ALL WARRANTIES, EXPRESS OR IMPLIED, INCLUDING, WITHOUT LIMITATION, ANY IMPLIED WARRANTIES OF MERCHANTABILITY, FITNESS FOR A PARTICULAR PURPOSE, OR NON-INFRINGEMENT OF THIRD-PARTY INTELLECTUAL PROPERTY RIGHTS.

These resources are intended for developers who are designing with Renesas products. You are solely responsible for (1) selecting the appropriate products for your application, (2) designing, validating, and testing your application, and (3) ensuring your application meets applicable standards, and any other safety, security, or other requirements. These resources are subject to change without notice. Renesas grants you permission to use these resources only to develop an application that uses Renesas products. Other reproduction or use of these resources is strictly prohibited. No license is granted to any other Renesas intellectual property or to any third-party intellectual property. Renesas disclaims responsibility for, and you will fully indemnify Renesas and its representatives against, any claims, damages, costs, losses, or liabilities arising from your use of these resources. Renesas' products are provided only subject to Renesas' Terms and Conditions of Sale or other applicable terms agreed to in writing. No use of any Renesas resources expands or otherwise alters any applicable warranties or warranty disclaimers for these products.

(Disclaimer Rev.1.01 Jan 2024)

Corporate Headquarters

TOYOSU FORESIA, 3-2-24 Toyosu,
Koto-ku, Tokyo 135-0061, Japan
www.renesas.com

Trademarks

Renesas and the Renesas logo are trademarks of Renesas Electronics Corporation. All trademarks and registered trademarks are the property of their respective owners.

Contact Information

For further information on a product, technology, the most up-to-date version of a document, or your nearest sales office, please visit www.renesas.com/contact-us/.