

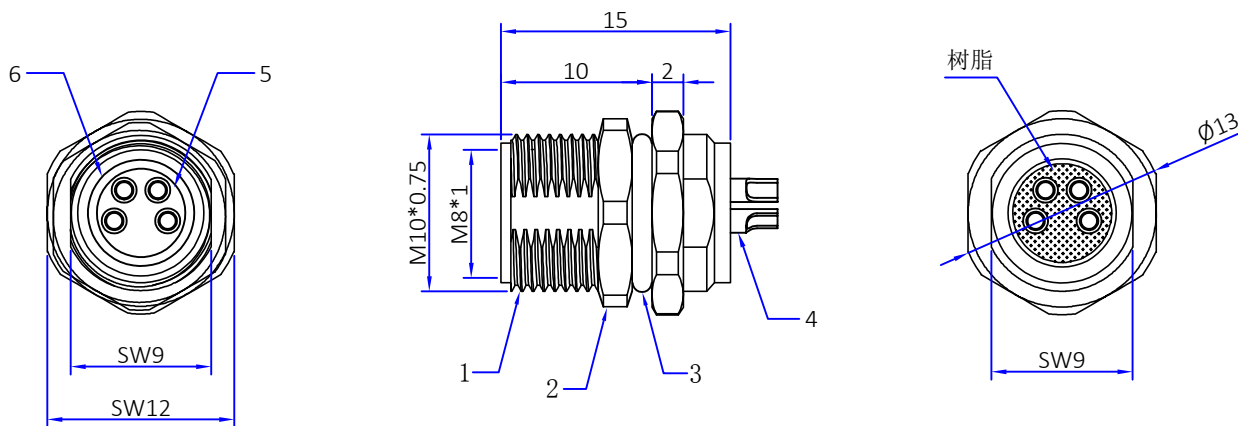

| Rev | 描述 Description | 变更编号 Change number | 日期 Date |
|-----|-------------------|-----------------------|------------|
| A | 首次发下 | --- | 2023/06/09 |

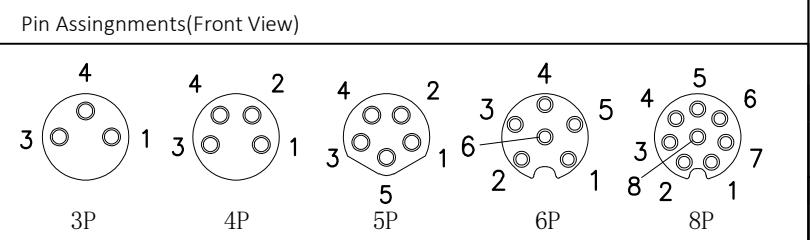

| 芯数 | 3 | 4 | 5 | 6 | 8 |
|-----------|--------|--------|--------|----------|----------|
| 额定电流/电压 | 3A/60V | 3A/60V | 3A/30V | 1.5A/30V | 1.5A/30V |
| 额定脉冲电压 | 800V | 800V | 800V | 800V | 800V |
| 绝缘阻抗 (MΩ) | ≥500 | ≥500 | ≥500 | ≥500 | ≥500 |
| 接触阻抗 (MΩ) | ≤5 | ≤5 | ≤5 | ≤5 | ≤5 |

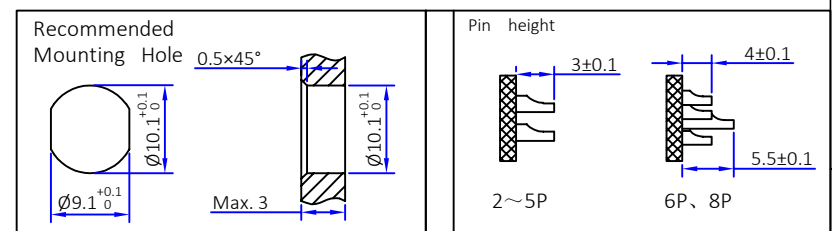

| No. | Specification | Material | Treat | Unit | Q'ty |
|-----|-------------------|----------|-------|------|------|
| 6 | M8 胶芯前端O型圈 | 橡胶 | / | pc | 1 |
| 5 | M8 母胶芯 | 尼龙 | 黑色 | pc | 1 |
| 4 | M8 焊线式母针 | 磷青铜 | 镀金 | pc | 3~8 |
| 3 | M8 外部O型圈 | 橡胶 | / | pc | 1 |
| 2 | M8 锁板六角螺母M10×0.75 | 黄铜 | 镀镍 | pc | 1 |
| 1 | M8 双切边母头前锁外壳 | 黄铜 | 镀镍 | pc | 1 |

| | | | |
|--|---|--|-------------|
| The View | | dosinconn DOSIN INDUSTRIAL(HK)CO.,LTD Web: http://www.dosinconn.com 江门市德索连接器有限公司 Jiangmen Dosin Connector Co., LTD Dosin2005@dosin-china.com Tel:(0086)769-81153906 Fax:(0086)769-81875836 | |
| 单位 unit | mm | 页码 page | 1/1 |
| 图号 Drawing NO | 料号 Part Number | 产品名称 Product name | |
| 文件保密 File security This drawing shall not be copied, circulated or used for other purposes without permission. 本图纸未经许可, 不可复制、外传或它用 | 未注公差 Unmarked tolerance | 绘图 Draw drawing | |
| | 零部件 Parts X. ±0.5 X.X ±0.20 X.XX ±0.10 | 线性 Line ≤10 ±1 10~50 ±1.5 >50 ±4% | 扶刘 |
| | 角度 angle ±3° | | 审核 Check |
| | | 客户确认 Customer confirmation | |