



MR2500 - MR2512

PRV : 50 - 1200 Volts
Io : 25 Amperes

FEATURES :

- * High current capability
- * High surge current capability
- * High reliability
- * Low reverse current
- * Low forward voltage drop
- * Pb / RoHS Free

MECHANICAL DATA :

- * Case : Molded plastic
- * Epoxy : UL94V-O rate flame retardant
- * Terminals : Terminal are readily solderable
- * Polarity : Cathode polarity band
- * Mounting position : Any
- * Weight : 1.624 grams

AUTOMOTIVE RECTIFIER DIODES

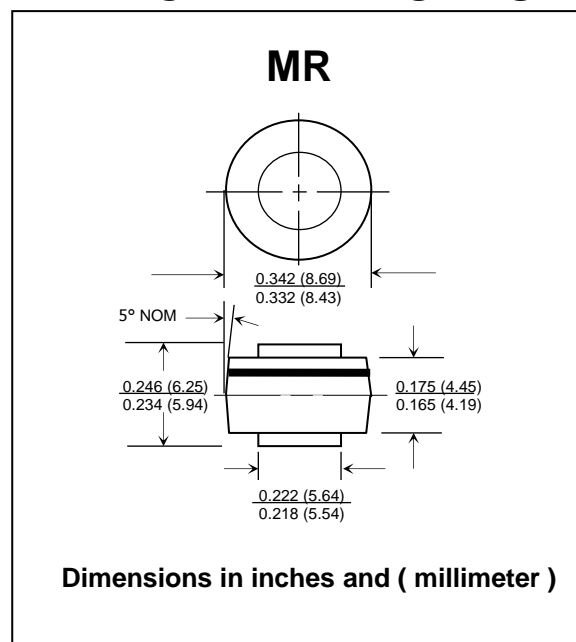

MAXIMUM RATINGS AND ELECTRICAL CHARACTERISTICS

Rating at 25 °C ambient temperature unless otherwise specified.

Single phase, half wave, 60 Hz, resistive or inductive load.

For capacitive load, derate current by 20%.

RATING	SYMBOL	MR 2500	MR 2501	MR 2502	MR 2504	MR 2506	MR 2508	MR 2510	MR 2512	UNIT
Maximum Repetitive Peak Reverse Voltage	V _{RRM}	50	100	200	400	600	800	1000	1200	V
Maximum RMS Voltage	V _{RMS}	35	70	140	280	420	560	700	840	V
Maximum DC Blocking Voltage	V _{DC}	50	100	200	400	600	800	1000	1200	V
Average Rectified Forward Current T _c = 150°C	I _{F(AV)}	25								A
Peak Forward Surge Current Single half sine wave superimposed on rated load (JEDEC Method)	I _{FSM}	400								A
Maximum Forward Voltage at I _F = 25 A	V _F	1.0								V
Maximum DC Reverse Current T _a = 25 °C at rated DC Blocking Voltage T _a = 100 °C	I _R	5.0								μA
	I _{R(H)}	1.0								mA
Thermal Resistance (Note 1)	R _{θJC}	0.8								°C/W
Junction Temperature Range	T _J	- 65 to + 175								°C
Storage Temperature Range	T _{STG}	- 65 to + 175								°C

Note : (1) Thermal resistance from junction to case. Single side cooled.



RATING AND CHARACTERISTIC CURVES (MR2500 - MR2512)

FIG.1 - DERATING CURVE FOR OUTPUT RECTIFIED CURRENT

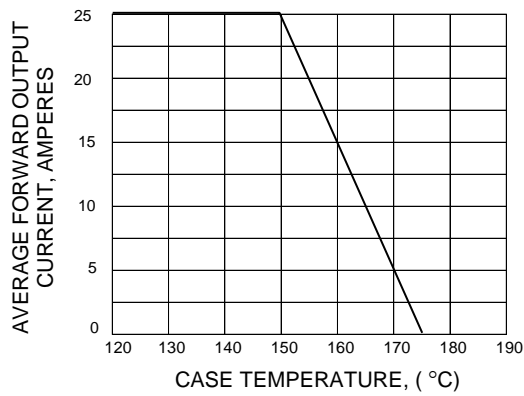

FIG.2 - MAXIMUM NON-REPETITIVE PEAK FORWARD SURGE CURRENT

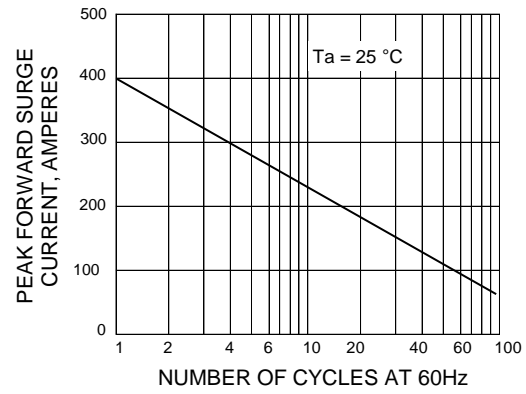

FIG.3 - TYPICAL FORWARD CHARACTERISTICS

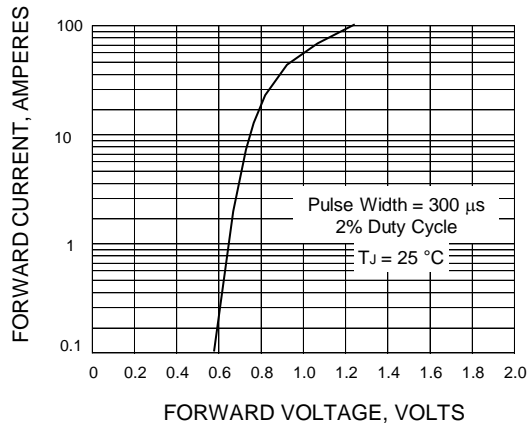

FIG.4 - TYPICAL REVERSE CHARACTERISTICS

