

MSNA

SMD current sensing resistor- metal strip



Applications

- Switched-mode power supply (SMPS)
- Voltage regulator module
- Power management
- Stepper motor drives

Environmental compliance



Product features

- Low sensing resistance
- 0612 (1632 metric) to 0915 (2338 metric)
- High power dissipation
- AEC-Q200 compliant
- Moisture sensitivity level (MSL): 1

Table 1. Part numbering configuration scheme

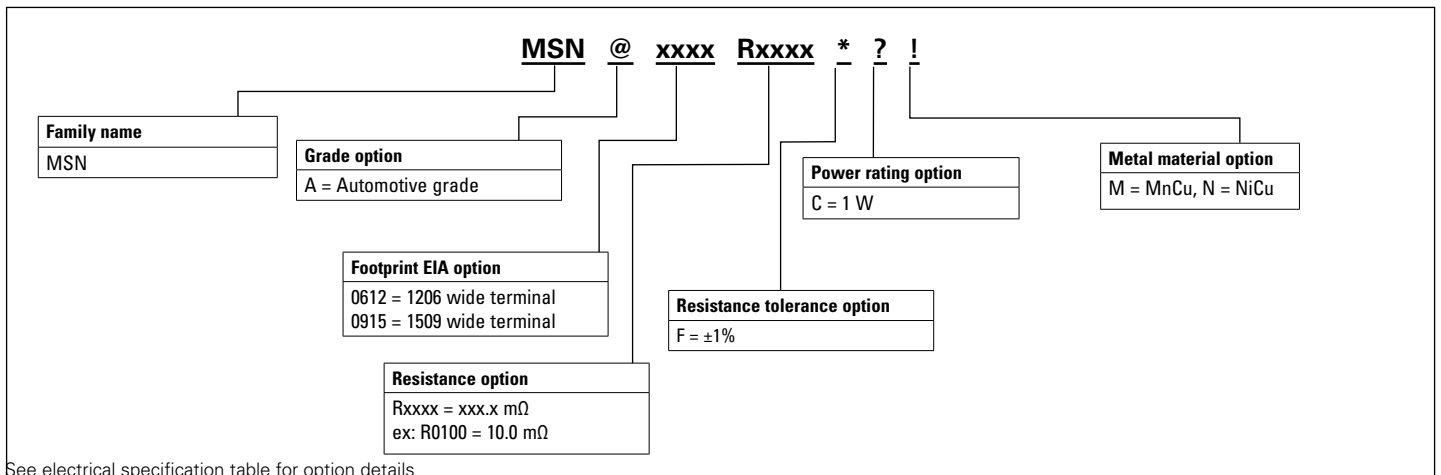

Powering Business Worldwide

Mechanical parameters- Inches [mm]

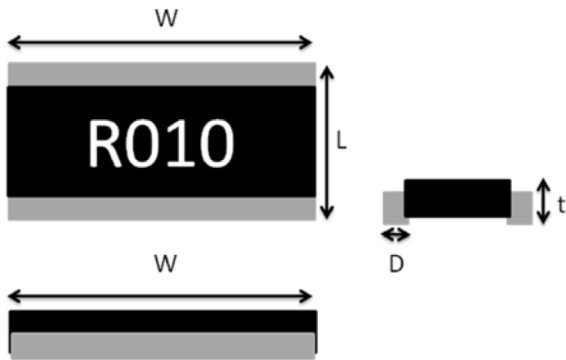

Construction

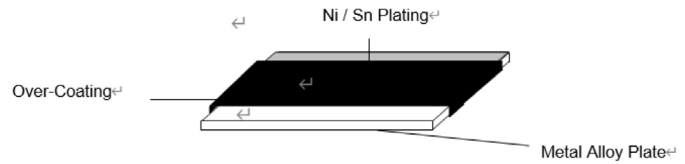

Family	Size code	L	W	D	t
MSNA0612	0612 [1632]	0.067 ± 0.008 [1.70 ± 0.20]	0.126 ± 0.008 [3.20 ± 0.20]	0.016 ± 0.008 [0.40 ± 0.20]	0.024 ± 0.008 [0.60 ± 0.20]
MSNA0915	0915 [2338]	0.091 ± 0.008 [2.30 ± 0.20]	0.148 ± 0.012 [3.75 ± 0.30]	0.020 ± 0.008 [0.50 ± 0.20]	0.028 ± 0.008 [0.70 ± 0.20]

Recommended PCB layout- mm

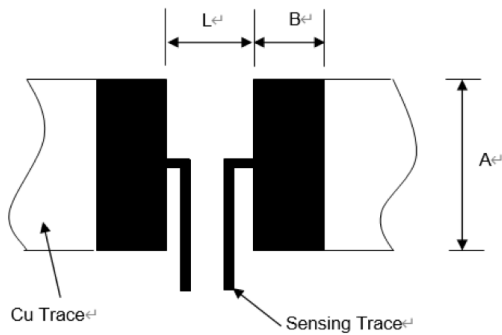

Family	Resistance (mΩ)	A	L	B
MSNA0612	1 ≤ R ≤ 10	3.8	0.7	0.7
MSNA0915	1 ≤ R ≤ 30	4.2	1.2	0.8

1. The copper foil minimum thickness of PCB needs 3 oz minimum.
2. PCB layout dimension tolerance is +/-0.1 mm.
3. The resistance will change slightly after soldered; it is dependent on PCB pad size design and it's necessary to consider the effect of the resistance increase or decrease.

Part marking

Family	Marking
MSNA0612	Resistance value is expressed by 4 digits.
MSNA0915	R001 = 0.001 Ω or 1 mΩ R030 = 0.030 Ω or 30 mΩ

Electrical specifications

Part number	Size	Grade option	Resistance value mΩ (Part number code)	Resistance tolerance (Part number code)	Power rating (Part number code)	Metal material (Part number code option)	TCR (ppm/°C)	Operating temperature
MSN@0612Rxxxx*?!	0612 (1632 metric)	A	1 (0010)	±1% (F)	1 W (C)	MnCu (M)	± 100	-55 °C to +170 °C
MSN@0612Rxxxx*?!	0612 (1632 metric)	A	2 (0020)	±1% (F)	1 W (C)	MnCu (M)	± 100	-55 °C to +170 °C
MSN@0612Rxxxx*?!	0612 (1632 metric)	A	3 (0030)	±1% (F)	1 W (C)	MnCu (M)	± 100	-55 °C to +170 °C
MSN@0612Rxxxx*?!	0612 (1632 metric)	A	5 (0050)	±1% (F)	1 W (C)	MnCu (M)	± 100	-55 °C to +170 °C
MSN@0612Rxxxx*?!	0612 (1632 metric)	A	10 (0100)	±1% (F)	1 W (C)	NiCu (N)	± 100	-55 °C to +170 °C
MSN@0915Rxxxx*?!	0915 (2338 metric)	A	8 (0080)	±1% (F)	1 W (C)	NiCu (N)	± 50	-55 °C to +170 °C
MSN@0915Rxxxx*?!	0915 (2338 metric)	A	10 (0100)	±1% (F)	1 W (C)	NiCu (N)	± 50	-55 °C to +170 °C
MSN@0915Rxxxx*?!	0915 (2338 metric)	A	15 (0150)	±1% (F)	1 W (C)	NiCu (N)	± 50	-55 °C to +170 °C
MSN@0915Rxxxx*?!	0915 (2338 metric)	A	20 (0200)	±1% (F)	1 W (C)	NiCu (N)	± 50	-55 °C to +170 °C
MSN@0915Rxxxx*?!	0915 (2338 metric)	A	25 (0250)	±1% (F)	1 W (C)	NiCu (N)	± 50	-55 °C to +170 °C
MSN@0915Rxxxx*?!	0915 (2338 metric)	A	30 (0300)	±1% (F)	1 W (C)	NiCu (N)	± 50	-55 °C to +170 °C
MSN@0915Rxxxx*?!	0915 (2338 metric)	A	1 (0010)	±1% (F)	1 W (C)	MnCu (M)	± 50	-55 °C to +170 °C
MSN@0915Rxxxx*?!	0915 (2338 metric)	A	3 (0030)	±1% (F)	1 W (C)	MnCu (M)	± 50	-55 °C to +170 °C
MSN@0915Rxxxx*?!	0915 (2338 metric)	A	5 (0050)	±1% (F)	1 W (C)	MnCu (M)	± 50	-55 °C to +170 °C
MSN@0915Rxxxx*?!	0915 (2338 metric)	A	6 (0060)	±1% (F)	1 W (C)	MnCu (M)	± 50	-55 °C to +170 °C
MSN@0915Rxxxx*?!	0915 (2338 metric)	A	10 (0100)	±1% (F)	1 W (C)	MnCu (M)	± 50	-55 °C to +170 °C
MSN@0915Rxxxx*?!	0915 (2338 metric)	A	15 (0150)	±1% (F)	1 W (C)	MnCu (M)	± 50	-55 °C to +170 °C
MSN@0915Rxxxx*?!	0915 (2338 metric)	A	20 (0200)	±1% (F)	1 W (C)	MnCu (M)	± 50	-55 °C to +170 °C

@= Enter grade option from table above (A=Automotive)

Rxxxx = Enter resistance code option from table above xxxx= resistance code (xxx.x mΩ ex: R0100 = 10.0 mΩ)

*= Enter resistance tolerance code option from table above (F= ±1%)

?= Enter power rating code option from table above (C = 1 W)

!=Enter metal material code option from table above (M = MnCu, N = NiCu)

Packaging information- mm

Supplied in tape and reel on a 7.0" diameter reel (EIA-481 compliant)

Size	Tape	Quantity
0612	7 inch paper	5K
0915	7 inch embossed	4K

Tape carrier and dimensions

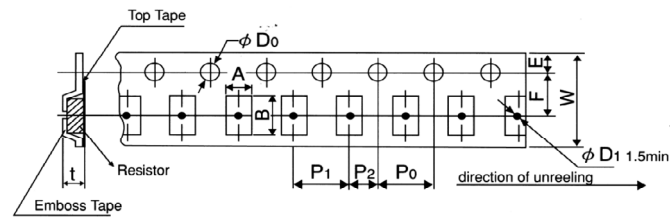
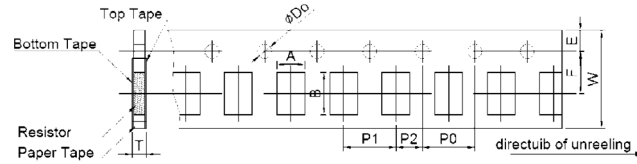

Dimension	0612	0915
E	1.75 ± 0.1	1.75 ± 0.1
F	3.5 ± 0.05	5.5 ± 0.05
P2	2.0 ± 0.1	2.0 ± 0.1
D0	1.50 ± 0.1	1.50 ± 0.1
P0	4.0 ± 0.1	4.0 ± 0.1
W	8.0 ± 0.1	12.0 ± 0.2
P1	4.0 ± 0.1	4.0 ± 0.1
A	2.0 ± 0.15	2.6 ± 0.2
B	3.6 ± 0.2	4.5 ± 0.2
T or t	0.84 ± 0.1	1.1 ± 0.1

Reel dimensions- mm

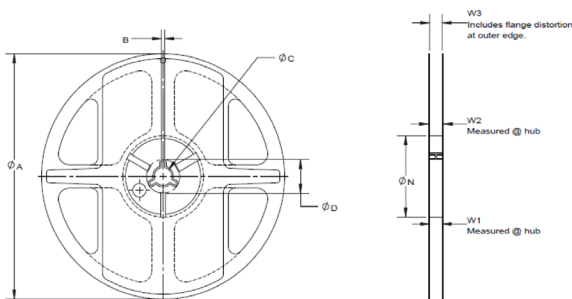

Size	A	B	C	D	N	W1	W2	W3
0612	178 ± 2.0	3.5 ± 0.5	13.0 ± 1.0	na	60 ± 1.0	9.0 ± 1.0	11.4 ± 1.0	na
0915	178 ± 2.0	3.5 ± 0.5	13.0 ± 1.0	na	60 ± 1.0	13.0 ± 1.0	15.4 ± 1.0	na

General specifications

Temperature coefficient of resistance: IEC60115-1 4.8, +25 to +125 °C
Short time overload: IEC60115-1 4.13, 5 X rated power for 5 s
High temperature exposure (storage): AEC-Q200-REV D-Test 3, MIL-STD202 Method 108, 1000 hours, +170 °C
Temperature cycling: AEC-Q200-REV D-Test 4, JESD22 Method JA-104, 1000 Cycles (-55 °C to +125 °C)
Moisture resistance: AEC-Q200-REV D-Test 6 , MIL-STD-202 Method 106, T=24 hours / Cycle ,10 Cycles, Notes: Steps 7a& 7b not required. Unpowered
Biased humidity: AEC-Q200-REV D-Test 7, MIL-STD-202 Method 103, 1000 hours +85 °C/85% RH. Note: Specified conditions: 10% of operating power (not exceeding max working voltage).
Operational life: AEC-Q200-REV D-Test 8, MIL-STD-202 Method 108, 1000 hours, +125 °C at rated derating power
Resistance to solvents: AEC-Q200-REV D-Test 12, MIL-STD-202 Method 215, a: Isopropyl Alcohol : Mineral Spirits= 1 : 3, b: Terpene Defluxer (Bioact EC-7R) c: Deionized water : Propylene Glycol Monomethyl Ether : monoethanolamine = 42 : 1 : 1, Marking and protective layer cannot be detached
Mechanical shock: AEC-Q200-REV D-Test 13, MIL-STD-202 Method 213, Wave Form Peak value is 100 g's. 6 ms
Vibration: AEC-Q200-REV D-Test 14, MIL-STD-202 Method 204, 5 g's for 20 min., 12 cycles each of 3 orientations
Resistance to soldering heat: AEC-Q200-REV D-Test 15, MIL-STD-202 Method 210, Condition B : Immerse the specimens in and eutectic solder at +260 ± 5 °C for 10 ± 1 s
Thermal shock: AEC-Q200-REV D-Test 16, MIL-STD-202 Method 107, -55 °C/+155 °C. Note: Number of cycles required 300, Maximum transfer time 20 seconds, Dwell time 15 minutes. Air-Air
ESD: AEC-Q200-REV D-Test 17, AEC-Q200-002 or ISO/DIS 10605, verify the voltage setting at 500 V
Solderability: AEC-Q200-REV D-Test 18, J-STD-002, Method B, aging 4 hours at 155 °C dry heat Lead-free solder bath at 235 ± 3 °C, Dipping time: 3 ± 0.5 seconds, > 95% area covered with tin
Flammability: AEC-Q200-REV D-Test 20, UL-94, V-0 or V-1 are acceptable. Electrical test not required. V-0 or V-1
Board flex (bending): AEC-Q200-REV D-Test 21, AEC-Q200-005, The duration of the applied forces shall be 60 (+ 5) Sec, 2 mm deflection
Terminal strength (SMD): AEC-Q200-REV D-Test 22, AEC-Q200-006, Force of 1.8 kg for 60 seconds

Temperature derating curve

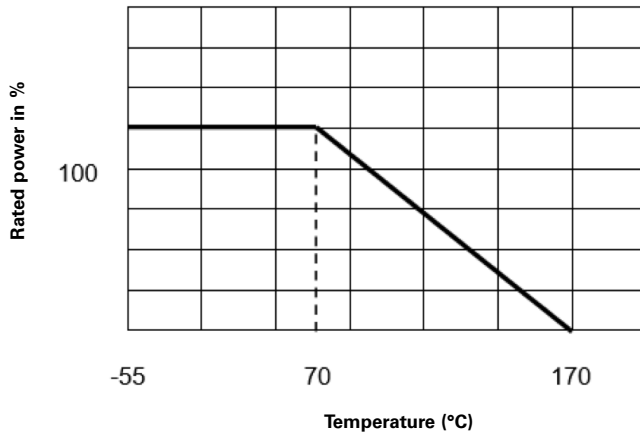

Rated current & voltage

The rated Current and Voltage are calculated by the following formula:

$$I = \sqrt{P \div R}$$

$$V = \sqrt{P \times R}$$

I: Rated current (A)

V: Rated voltage (V)

P: Rated power (W)

R: Resistance value (Ω)

Solder reflow profile

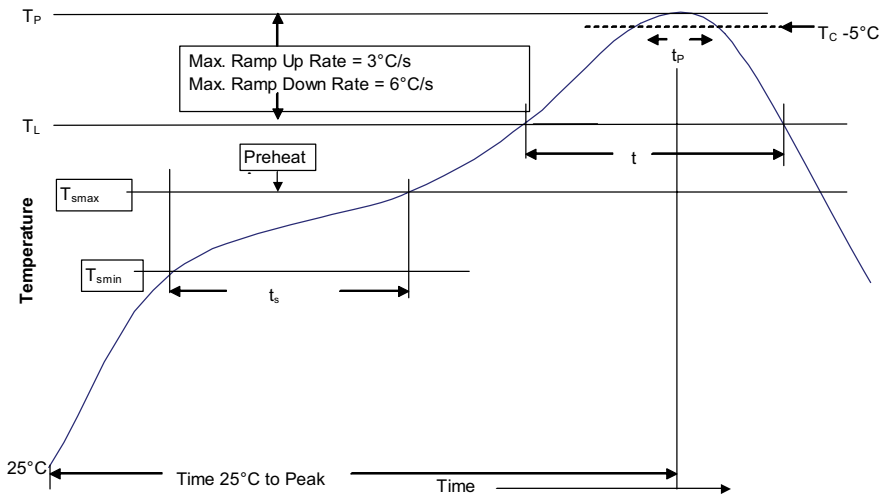

Profile feature	Lead (Pb) free solder
Preheat and soak	
• Temperature min. (T_{smin})	150 °C
• Temperature max. (T_{smax})	200 °C
• Time (T_{smin} to T_{smax}) (t_s)	60-150 seconds
Ramp up rate T_L to T_p	3 °C/ second max.
Liquidous temperature (T_L)	217 °C
Time (t_L) maintained above T_L	60-120 seconds
Peak package body temperature (T_p)*	260 °C
Time (t_p)* within 5 °C of the specified classification temperature (T_c)	10 seconds*
Ramp-down rate (T_p to T_L)	6 °C/ second max.
Time 25 °C to peak temperature	8 minutes max.

* Tolerance for peak profile temperature (T_p) is defined as a supplier minimum and a user maximum.

Manual solder

+350 °C ±10 °C , 3 +1/0 seconds 1 time (by soldering iron), generally manual, hand soldering is not recommended

Life Support Policy: Eaton does not authorize the use of any of its products for use in life support devices or systems without the express written approval of an officer of the Company. Life support systems are devices which support or sustain life, and whose failure to perform, when properly used in accordance with instructions for use provided in the labeling, can be reasonably expected to result in significant injury to the user.

Eaton reserves the right, without notice, to change design or construction of any products and to discontinue or limit distribution of any products. Eaton also reserves the right to change or update, without notice, any technical information contained in this bulletin.

Eaton
Electronics Division
1000 Eaton Boulevard
Cleveland, OH 44122
United States
Eaton.com/electronics

© 2022 Eaton
All Rights Reserved
Printed in USA
Publication No. ELX1183 BU-ELX22043
June 2022

Eaton is a registered trademark.

All other trademarks are property of their respective owners.

Follow us on social media to get the latest product and support information.

