

**Material :**

- (a) Cover : PA66(UL94V-0)
- (b) Contact : Phosphor Bronze
- (c) Cage : Brass , Ni Plated
- (d) Housing : PA66(UL94V-0)
- (e) Screws : Steel , Cr<sup>3+</sup>Zn Plated

**Electrical :**

- |                              |                  |                    |
|------------------------------|------------------|--------------------|
|                              | UL               | IEC                |
| 1.Rated Voltage :            | 300V             | 320V               |
| 2.Rated Current :            | 15A              | 10A                |
| 3.Torque Value :             | M2.5 , 3.54Lb.in | M2.5 , 0.4N.m      |
| 4.Wire Range:                | 28-12AWG         | 2.5mm <sup>2</sup> |
| 5.Stripping Length :         | 7-8mm            |                    |
| 6.Withstanding Voltage :     | AC1600V/1Min.    |                    |
| 7.Operating Temperature :    | -40 °C~+105 °C   |                    |
| 8.RoHS Compliance            |                  |                    |
| 9.Safety Approval :          | cULus            |                    |
| 10.Undimensioned Tolerances: |                  |                    |

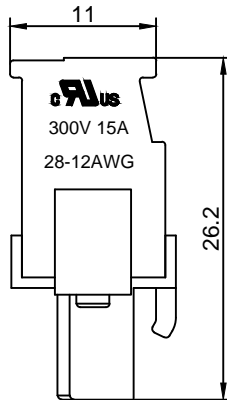
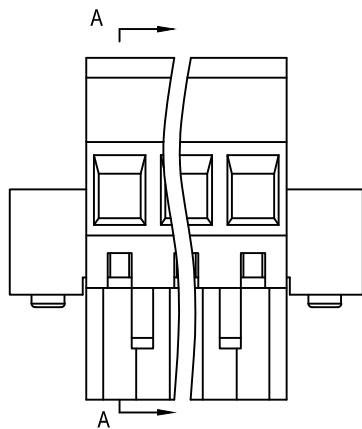
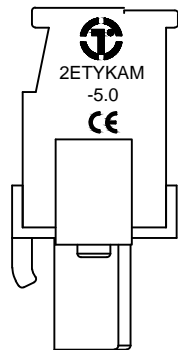

Pitch Range In mm		Nominal Dimension Range In mm					—	∩	∇
≤6	6 ~ 10	10 ~ 24	≤30	30 ~ 60	60 ~ 100	100 ~ 150	>150	0.05/10	
±0.10	±0.15	±0.25	±0.20	±0.30	±0.50	±0.70	±1.00	±0.1°	

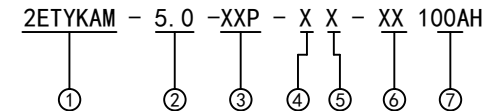

- ① Series NO.
- ② Pitch
- ③ Poles  
02 02Contacts  
03 03Contacts  
...  
24 24Contacts
- ④ 1 Single Pitch  
2 Double Pitch
- ⑤ Color: 1 Grey  
2 Blue  
3 Black  
4 Green(Standard For AH)  
5 Orange  
6 Red  
7 Transparent  
8 Yellow  
9 White
- ⑥ Customer Request: 100--Standard M2.5
- ⑦ AH--Standard(PA66)

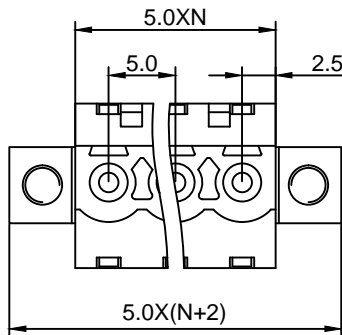
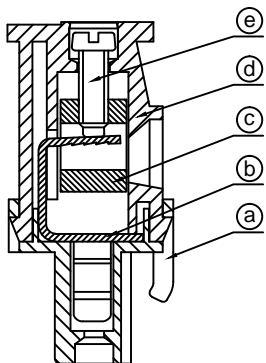

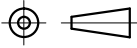
DETACHED LISTS	 <b>拓宜(上海)工控电器设备有限公司</b> Topone(Shanghai) Industrial Control Electrical Equipment Co., LTD.										
	APPD: MA_9/16/16'	PART NO. 2ETYKAM-5.0-XXP-XX-100AH									
	CHKD: Yu_9/15/16'										
	DRFT: Chen_9/14/16'										
 THIRD ANGLE PROJECTION		<table border="1"> <tr> <td>DRAWING NO.</td> <td>REV</td> <td>1</td> </tr> <tr> <td></td> <td>SHEET</td> <td>1/1</td> </tr> <tr> <td>MM (INCH)</td> <td>DO NOT SCALE DRAWING</td> <td>SCALE</td> </tr> </table>	DRAWING NO.	REV	1		SHEET	1/1	MM (INCH)	DO NOT SCALE DRAWING	SCALE
DRAWING NO.	REV	1									
	SHEET	1/1									
MM (INCH)	DO NOT SCALE DRAWING	SCALE									

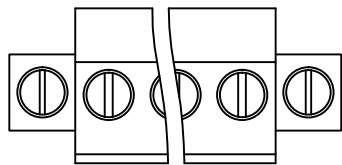

**Material :**

- (a) Cover : PA66(UL94V-0)
- (b) Contact : Phosphor Bronze
- (c) Cage : Brass , Ni Plated
- (d) Housing : PA66(UL94V-0)
- (e) Screws : Steel , Cr<sup>3+</sup>Zn Plated

**Electrical :**

- |                              |                  |                    |
|------------------------------|------------------|--------------------|
|                              | UL               | IEC                |
| 1.Rated Voltage :            | 300V             | 320V               |
| 2.Rated Current :            | 15A              | 10A                |
| 3.Torque Value :             | M2.5 , 3.54Lb.in | M2.5 , 0.4N.m      |
| 4.Wire Range:                | 28-12AWG         | 2.5mm <sup>2</sup> |
| 5.Stripping Length :         | 7-8mm            |                    |
| 6.Withstanding Voltage :     | AC1600V/1Min.    |                    |
| 7.Operating Temperature :    | -40 °C~+105 °C   |                    |
| 8.RoHS Compliance            |                  |                    |
| 9.Safety Approval :          | cULus            |                    |
| 10.Undimensioned Tolerances: |                  |                    |

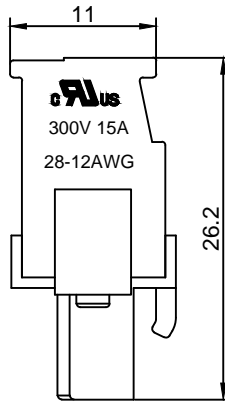
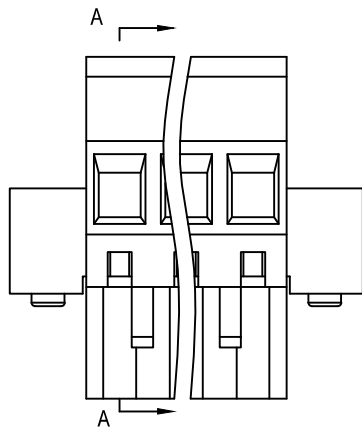
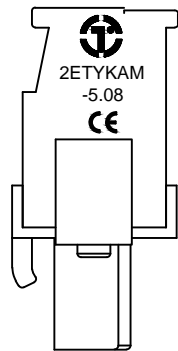

Pitch Range In mm		Nominal Dimension Range In mm					
≤6	6 ~ 10	10 ~ 24	≤30	30 ~ 60	60 ~ 100	100 ~ 150	>150
±0.10	±0.15	±0.25	±0.20	±0.30	±0.50	±0.70	±1.00
							0.05/10
							∠

2ETYKAM - 5.08 -XXP - X X - XX AH

①                      ②                      ③                      ④                      ⑤                      ⑥                      ⑦

- ① Series NO.
- ② Pitch
- ③ Poles  
02 02Contacts  
03 03Contacts  
...  
24 24Contacts
- ④ 1 Single Pitch  
2 Double Pitch
- ⑤ Color: 1 Grey  
2 Blue  
3 Black  
4 Green(Standard For AH)  
5 Orange  
6 Red  
7 Transparent  
8 Yellow  
9 White
- ⑥ Customer Request: 00--Standard M2.5
- ⑦ AH--Standard(PA66)

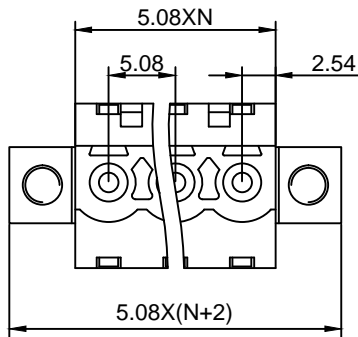
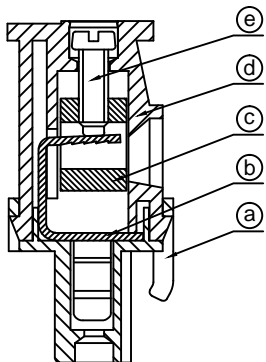

DETACHED LISTS	<b>拓宜(上海)工控电器设备有限公司</b> Topone(Shanghai) Industrial Control Electrical Equipment Co., LTD.													
	APPD: MA_9/16/16'	PART NO. <b>2ETYKAM-5.08-XXP-XX-XXAH</b>												
	CHKD: Yu_9/15/16'													
	DRFT: Chen_9/14/16'													
THIRD ANGLE PROJECTION		<table border="1" style="width: 100%;"> <tr> <td>DRAWING NO.</td> <td>REV</td> <td>1</td> </tr> <tr> <td></td> <td>SHEET</td> <td>1/1</td> </tr> <tr> <td style="text-align: center;">MM (INCH)</td> <td>DO NOT SCALE DRAWING</td> <td>SCALE</td> </tr> <tr> <td></td> <td></td> <td>1/1</td> </tr> </table>	DRAWING NO.	REV	1		SHEET	1/1	MM (INCH)	DO NOT SCALE DRAWING	SCALE			1/1
DRAWING NO.	REV	1												
	SHEET	1/1												
MM (INCH)	DO NOT SCALE DRAWING	SCALE												
		1/1												