

302-ST(-DS)

Plug-in terminal strip
Screw connection & pin

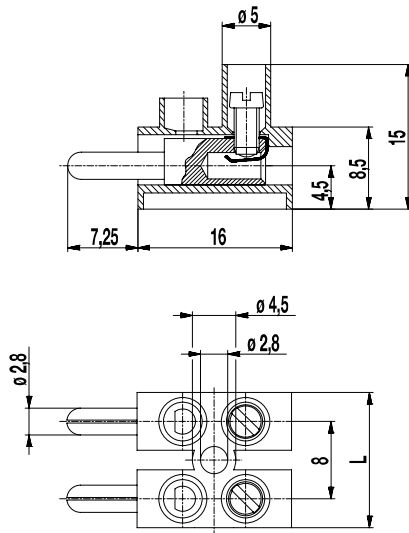

The plug-in terminal strip 302-ST is available in 8 mm pitch with 1 to 12 poles. It has one screw connection per pole and one vertical pin for the connection to the socket of the female counterpart.

The slotted pins and slotted sockets of plug-in terminal strip 302-STB create appropriate contact pressure. Due to the small 8 mm pitch, this version is well suited for applications where space is limited.

The wire protector of the "DS"-version reliably prevents damage to multi-wire flexible conductors by the turning screw. These terminal strips can be screw-mounted on a substrate.

Part Numbers

No. of poles	302-ST	302-ST(-DS)	Length	PU
2	12.820.009	72.820.009	15,00	1000
3	13.820.009	73.820.009	23,00	1000
4	14.820.009	74.820.009	31,00	500
5	15.820.009	75.820.009	39,00	500
6	16.820.009	76.820.009	47,00	80
7	17.820.009	77.820.009	55,00	60
8	18.820.009	78.820.009	63,00	70
9	19.820.009	79.820.009	71,00	60
10	20.820.009	80.820.009	79,00	40
11	21.820.009	81.820.009	87,00	40
12	22.820.009	82.820.009	94,00	40

General Information

Pitch	8 mm
No. of poles	2 - 12
Usable with	302-STB(-DS)
Areas of application	Applications that require to easily open and close not energised circuits.



Technical Data

Clamping Range	<i>solid / flexible / AWG</i>
<i>without wire protector</i>	0,5 - 4 mm ² / 0,5 - 2,5 mm ² / 20 - 12 AWG
<i>with wire protector</i>	0,34 - 2,5 mm ² / 0,34 - 1,5 mm ² / 22 - 14 AWG
Rated Cross Section	1,5 mm ²
Wire Stripping Length	6 mm ± 0,5 mm
Overvoltage Category	III III II
Pollution Severity Level	3 2 2
Rated Voltage	200 V 320 V 630 V
Rated Impulse Voltage	4 kV 4 kV 4 kV
Rated Insulation Voltage	450 V acc. to EN 60998-1
Rated Current	6 A
Torque	0,4 Nm
Other specifications	Rated values apply to use in combination with 302-STB(-DS) and without insulated substrates.

Material

Moulding	PA, natural, V-2
Comparative Tracking Index	CTI ≥ 600
Insulating Group	I
Temperature Range	-40°C up to 100°C
Terminal Body	Nickel plated brass
Screw	M2,6; zinc plated steel, blue passivated
Wire protector	Tin plated tin bronze
Plug	Nickel plated brass

Approvals

	Current [A]	Voltage [V]	Group	AWG	[Nm]
	6	300	B,D	20 - 14	0,4
	10	300	B,D,E	26 - 12	0,4 [1]

[1] for 302-ST(-DS): 26 - 14 AWG

Options / Accessories

- Marking options on the screw guides
- Jumper 302-J
- Moulding made of special polyamide for e.g. household appliances
- Screws made out of brass
- With pegs at the base for saving assembly time