

◆ Features:

- ◇ Fast switching speed
开关速度快
- ◇ High input impedance and low level drive
高输入阻抗和低电平驱动
- ◇ Avalanche energy tested
雪崩能量测试
- ◇ Improved dv/dt capability, high ruggedness
提高 dv/dt 能力, 高耐用性

◆ Applications

- ◇ High efficiency switch mode power supplies
高效率开关电源
- ◇ Power factor correction
功率因数校正
- ◇ Electronic lamp ballast
电子整流器

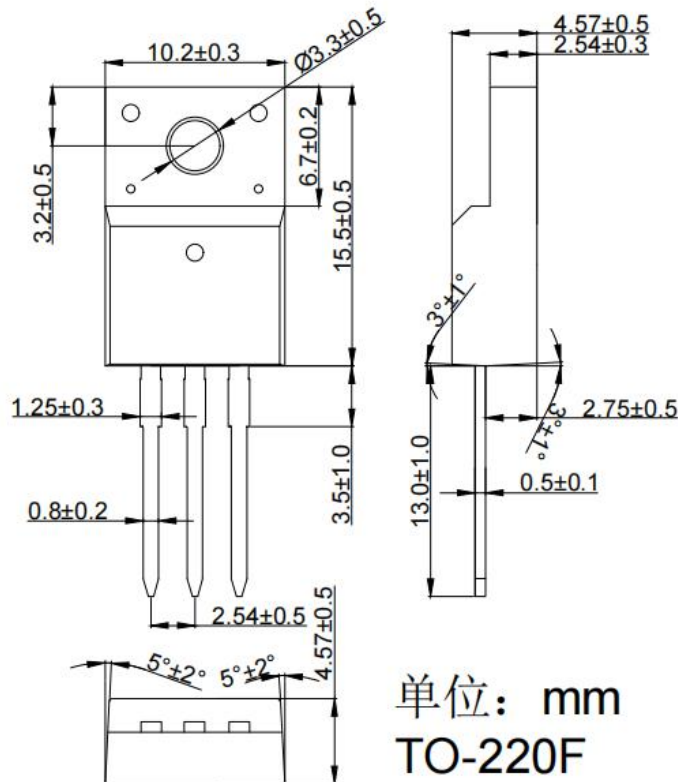
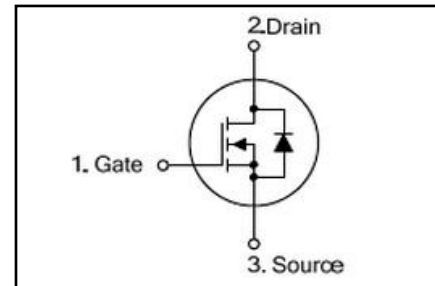
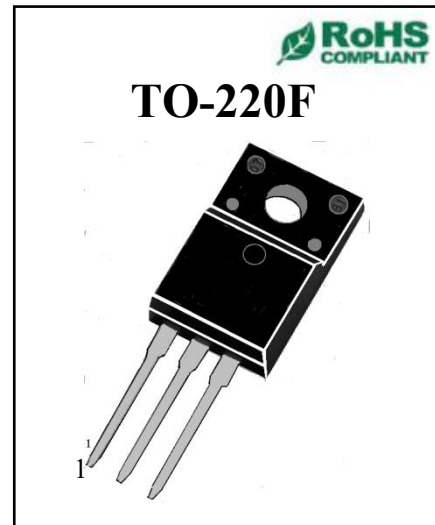

单位: mm
TO-220F

◆ Absolute Maximum Ratings (Tc=25°C)

Symbol	Parameters	Ratings	Unit
V _{DSS}	Drain-Source Voltage 漏源电压	500	V
V _{GS}	Gate-Source Voltage-Continuous 栅源电压	±30	V
I _D	Drain Current-Continuous (Note 2) 漏极持续电流	11	A
I _{DM}	Drain Current-Single Plused (Note 1) 漏极单次脉冲电流	44	A
P _D	Power Dissipation (Note 2) 功率损耗	48	W
T _j	Max.Operating junction temperature 最大结温	150	°C

◆ Electrical characteristics (Tc=25°C unless otherwise noted)

Symbol	Parameters	Min	Typ	Max	Units	Conditions
Static Characteristics						
B _{VDSS}	Drain-Source Breakdown VoltageCurrent (Note 1) 漏极击穿电压	500	--	--	V	I _D =250μA, V _{GS} =0V, T _J =25°C
V _{GS(th)}	Gate Threshold Voltage 栅极开启电压	2.0	--	4.0	V	V _{DS} =V _{GS} , I _D =250μA
R _{DS(on)}	Drain-Source On-Resistance 漏源导通电阻	--	0.49	--	Ω	V _{GS} =10V, I _D =5.5A
I _{GSS}	Gate-Body Leakage Current 栅极漏电流	--	--	±100	nA	V _{GS} =±30V, V _{DS} =0
I _{DSS}	Zero Gate Voltage Drain Current 零栅极电压漏极电流	--	--	1	μA	V _{DS} =500V, V _{GS} =0
Switching Characteristics						

$T_{d(on)}$	Turn-On Delay Time 开启延迟时间	--	25	60	ns	$V_{DS}=250V, I_D=11A,$ $R_G=3\Omega$ (Note 2)
T_r	Rise Time 上升时间	--	100	210	ns	
$T_{d(off)}$	Turn-Off Delay Time 关闭延迟时间	--	130	270	ns	
T_f	Fall Time 下降时间	--	100	210	ns	
Q_g	Total Gate Charge 栅极总电荷	--	43	56	nC	$V_{DS}=400, V_{GS}=10V,$ $I_D=11A$ (Note 2)
Q_{gs}	Gate-Source Charge 栅源极电荷	--	7.5	--	nC	
Q_{gd}	Gate-Drain Charge 栅漏极电荷	--	18.5	--	nC	
Dynamic Characteristics						
C_{iss}	Input Capacitance 输入电容	--	1515	2055	pF	$V_{DS}=25V, V_{GS}=0,$ $f=1MHz$
C_{oss}	Output Capacitance 输出电容	--	180	235	pF	
C_{rss}	Reverse Transfer Capacitance 反向传输电容	--	20	25	pF	
I_S	Continuous Drain-Source Diode Forward Current (Note 2) 二极管导通正向持续电流	--	--	11	A	
V_{SD}	Diode Forward On-Voltage 二极管正向导通电压	--	--	1.4	V	$I_S=11A, V_{GS}=0$
$R_{th(j-c)}$	Thermal Resistance, Junction to Case 结到外壳的热阻	--	--	2.6	$^{\circ}C/W$	

Note 1: Repetitive Rating : Pulse width limited by maximum junction temperature

Note 2: Pulse test: PW \leq 300us , duty cycle \leq 2%.