

650V N-CHANNEL MOSFET

◆ Features:

- ◇ Fast switching speed
开关速度快
- ◇ High input impedance and low level drive
高输入阻抗和低电平驱动
- ◇ Avalanche energy tested
雪崩能量测试
- ◇ Improved dv/dt capability, high ruggedness
提高 dv/dt 能力, 高耐用性

◆ Applications

- ◇ High efficiency switch mode power supplies
高效率开关电源
- ◇ Power factor correction
功率因数校正
- ◇ Electronic lamp ballast
电子整流器



TO-252



1

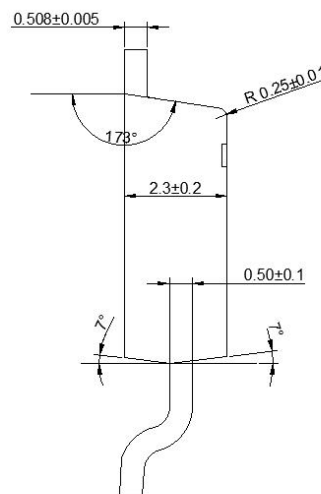
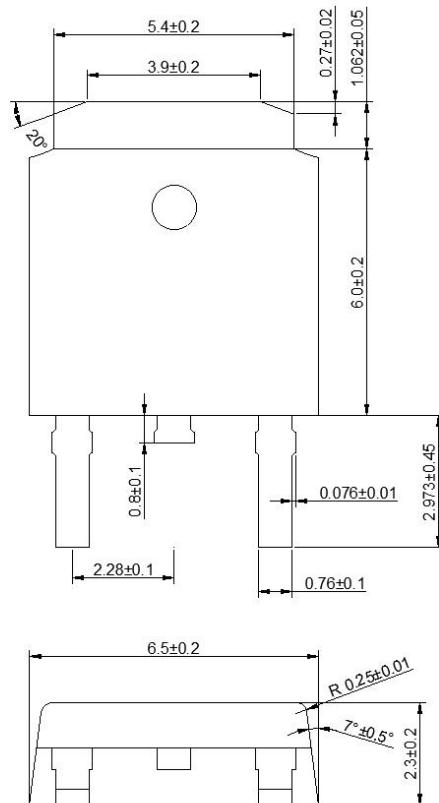
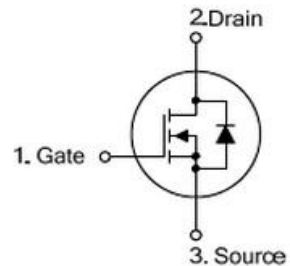

单位: mm
TO-252

◆ Absolute Maximum Ratings (Tc=25°C)

Symbol	Parameters	Ratings	Unit
V _{DSS}	Drain-Source Voltage 漏源电压	650	V
V _{GS}	Gate-Source Voltage-Continuous 栅源电压	±30	V
I _D	Drain Current-Continuous (Note 2) 漏极持续电流	5	A
I _{DM}	Drain Current-Single Plused (Note 1) 漏极单次脉冲电流	18	A
P _D	Power Dissipation (Note 2) 功率损耗	32	W
T _j	Max.Operating junction temperature 最大结温	150	°C

◆ Electrical characteristics (Tc=25°C unless otherwise noted)

Symbol	Parameters	Min	Typ	Max	Units	Conditions
Static Characteristics						
B _{VDSS}	Drain-Source Breakdown VoltageCurrent (Note 1) 漏极击穿电压	650	--	--	V	I _D =250μA, V _{GS} =0V, T _J =25°C
V _{GS(th)}	Gate Threshold Voltage 栅极开启电压	2.0	--	4.0	V	V _{DS} =V _{GS} , I _D =250μA
R _{DS(on)}	Drain-Source On-Resistance 漏源导通电阻	--	2.3	2.8	Ω	V _{GS} =10V, I _D =2.5A
I _{GSS}	Gate-Body Leakage Current 栅极漏电流	--	--	±100	nA	V _{GS} =±30V, V _{DS} =0
I _{DSS}	Zero Gate Voltage Drain Current 零栅极电压漏极电流	--	--	1	μA	V _{DS} =650V, V _{GS} =0
g _{fs}	Forward Transconductance 正向跨导	1.2	--	--	S	V _{DS} =15V, I _D =2.5A

650V N-CHANNEL MOSFET

Switching Characteristics						
$T_{d(on)}$	Turn-On Delay Time 开启延迟时间	--	20	40	ns	$V_{DS}=325V, I_D=5A,$ $R_G=25\Omega$ (Note 2)
T_r	Rise Time 上升时间	--	45	100	ns	
$T_{d(off)}$	Turn-Off Delay Time 关闭延迟时间	--	35	75	ns	
T_f	Fall Time 下降时间	--	35	85	ns	
Q_g	Total Gate Charge 栅极总电荷	--	15	20	nC	$V_{DS}=520V$, $V_{GS}=10V,$ $I_D=5A$ (Note 2)
Q_{gs}	Gate-Source Charge 栅源极电荷	--	3.5	--	nC	
Q_{gd}	Gate-Drain Charge 栅漏极电荷	--	7.5	--	nC	
Dynamic Characteristics						
C_{iss}	Input Capacitance 输入电容	--	515	670	pF	$V_{DS}=25V, V_{GS}=0,$ $f=1MHz$
C_{oss}	Output Capacitance 输出电容	--	65	80	pF	
C_{rss}	Reverse Transfer Capacitance 反向传输电容	--	7.5	10.5	pF	
I_S	Continuous Drain-Source Diode Forward Current (Note 2) 二极管导通正向持续电流	--	--	5	A	
V_{SD}	Diode Forward On-Voltage 二极管正向导通电压	--	--	1.4	V	$I_S=5A, V_{GS}=0$
$R_{th(j-c)}$	Thermal Resistance, Junction to Case 结到外壳的热阻	--	--	3.9	$^{\circ}C/W$	

Note 1: Repetitive Rating : Pulse width limited by maximum junction temperature

Note 2: Pulse test: $PW \leq 300\mu s$, duty cycle $\leq 2\%$.