

RECOMMENDED PANEL CUTOUT

| PANEL THICKNESS | X |
|-----------------|------|
| 0.75 - 1.25 | 19.2 |
| 1.25 - 2.00 | 19.4 |
| 2.00 - 3.00 | 19.6 |

| SWITCH FUNCTION | |
|-----------------|--------|
| POS. 1 | POS. 2 |
| | |
| OFF | ON |
| OPEN | 2-1 |

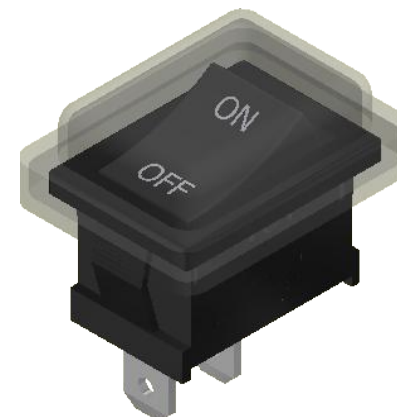
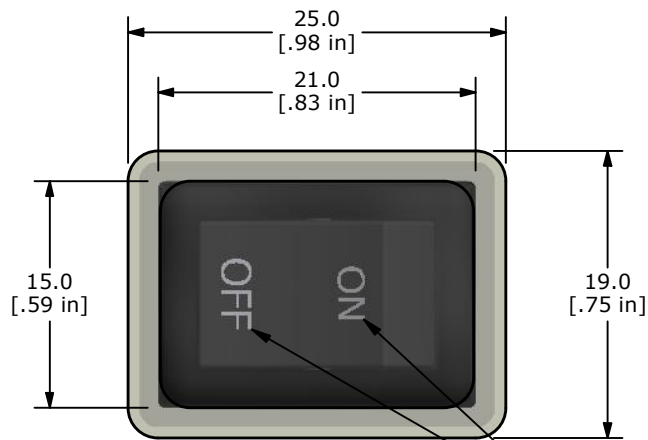
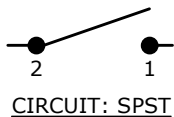

▲ GRAPHIC COLOR: WHITE

▲ ACTUATOR COLOR: BLACK

▲ BODY COLOR: BLACK

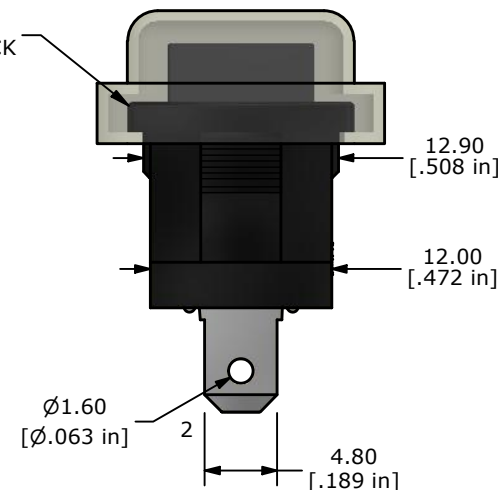
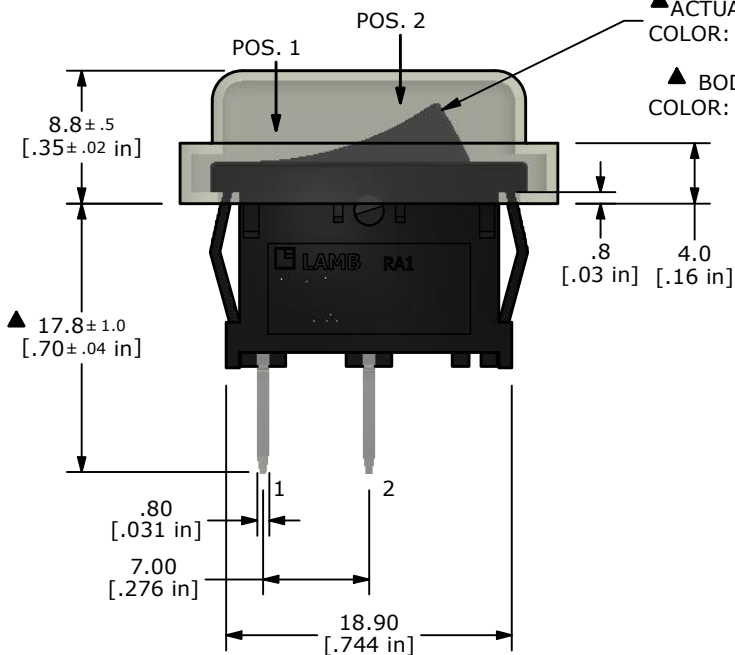

NOTE:

1. DIMENSIONS IN MM [INCH]
2. GENERAL TOLERANCE: X.X = ± 0.4
X.XX = ± 0.25
3. TERMINAL NUMBERS FOR REF ONLY
4. CONTACT MATERIAL: SILVER
- ▲ 5. CONTACT RATINGS: 10A @ 125VAC [UR, cUR]
6. CONTACT RESISTANCE: 35mΩ MAX. @ 50VAC
7. INSULATION RESISTANCE: 100MΩ MIN. @ 500VAC
8. DIELECTRIC STRENGTH: 1,500VAC FOR 1 MINUTE
9. ELECTRICAL LIFE: 6,000 CYCLES [UR, cUR]
10. OPERATING TEMPERATURE: -20°C to 105°C [UR, cUR]
11. ▲ DENOTES CRITICAL PARAMETER

| REV | ECO NO | DESCRIPTION | DATE | BY |
|-----|------------|---------------------------------|----------|----|
| C | ECO-101272 | RA1 SERIES UPDATE | 10/11/22 | MR |
| B | ECO-100452 | REMOVE VDE/ENEC RATING AND LOGO | 01/11/22 | JS |



OBJECT ID
000001425

| | | | | | | |
|-----------------------------|--|--------------|------------------|----------|---------------------|----------|
| TITLE RA11131123/ACC-P01 | | SCALE 2:1 | DATE 1/8/2018 | DR MW | DWG 38-RA1S00266 | REV C |
|-----------------------------|--|--------------|------------------|----------|---------------------|----------|