

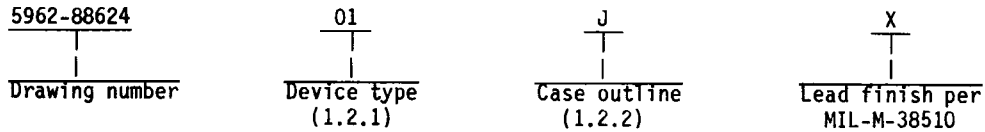

1. SCOPE

1.1 Scope. This drawing describes device requirements for class B microcircuits in accordance with 1.2.1 of MIL-STD-883, "Provisions for the use of MIL-STD-883 in conjunction with compliant non-JAN devices".

1.2 Part number. The complete part number shall be as shown in the following example:



1.2.1 Device type. The device type shall identify the circuit function as follows:

Device type	Generic number	Circuit function
01	54HCT4059	Programmable, divide-by-N counter with TTL compatible inputs

1.2.2 Case outline. The case outline shall be as designated in appendix C of MIL-M-38510, and as follows:

Outline letter	Case outline
J	D-3 (24-lead, 1.290" x .610" x .225"), dual-in-line package

1.3 Absolute maximum ratings.

Supply voltage range <sup>1/</sup> - - - - -	-0.5 V dc to +7.0 V dc
DC input voltage ( $V_{IN}$ ) - - - - -	-0.5 V dc to $V_{CC} + 0.5$ V dc
DC output voltage ( $V_{OUT}$ ) - - - - -	-0.5 V dc to $V_{CC} + 0.5$ V dc
Clamp diode current - - - - -	±20 mA
DC output current (per pin) - - - - -	±25 mA
DC $V_{CC}$ or GND current (per pin) - - - - -	±50 mA
Storage temperature range - - - - -	-65°C to +150°C
Maximum power dissipation ( $P_D$ ) - - - - -	500 mW <sup>2/</sup>
Lead temperature (soldering, 10 seconds) - - - - -	+260°C
Thermal resistance, junction-to-case ( $\theta_{JC}$ ):	
Case J - - - - -	See MIL-M-38510, appendix C
Junction temperature ( $T_J$ ) - - - - -	+175°C

1.4 Recommended operating conditions.

Supply voltage range ( $V_{CC}$ ) - - - - -	4.5 V dc to 5.5 V dc
Case operating temperature range - - - - -	-55°C to +125°C
Input rise or fall time:	
$V_{CC} = 4.5$ V - - - - -	0 to 500 ns
Minimum setup time, data to clock ( $t_s$ ):	
$T_C = +25^\circ\text{C}$ , $V_{CC} = 4.5$ V - - - - -	15 ns
$T_C = -55^\circ\text{C}$ to +125°C, $V_{CC} = 4.5$ V - - - - -	22 ns
Minimum clock pulse width ( $t_w$ ):	
$T_C = +25^\circ\text{C}$ , $V_{CC} = 4.5$ V - - - - -	20 ns
$T_C = -55^\circ\text{C}$ to +125°C, $V_{CC} = 4.5$ V - - - - -	30 ns

<sup>1/</sup> Unless otherwise specified, all voltages are referenced to ground.

<sup>2/</sup> For  $T_C = +100^\circ\text{C}$  to +125°C, derate linearly at 12 mW/°C.

<b>STANDARDIZED MILITARY DRAWING</b> DEFENSE ELECTRONICS SUPPLY CENTER DAYTON, OHIO 45444	SIZE <b>A</b>	5962-88624
	REVISION LEVEL	SHEET 2

2. APPLICABLE DOCUMENTS

2.1 Government specification and standard. Unless otherwise specified, the following specification and standard, of the issue listed in that issue of the Department of Defense Index of Specifications and Standards specified in the solicitation, form a part of this drawing to the extent specified herein.

SPECIFICATION

MILITARY

MIL-M-38510 - Microcircuits, General Specification for.

STANDARD

MILITARY

MIL-STD-883 - Test Methods and Procedures for Microelectronics.

(Copies of the specification and standard required by manufacturers in connection with specific acquisition functions should be obtained from the contracting activity or as directed by the contracting activity.)

2.2 Order of precedence. In the event of a conflict between the text of this drawing and the references cited herein, the text of this drawing shall take precedence.

3. REQUIREMENTS

3.1 Item requirements. The individual item requirements shall be in accordance with 1.2.1 of MIL-STD-883, "Provisions for the use of MIL-STD-883 in conjunction with compliant non-JAN devices" and as specified herein.

3.2 Design, construction, and physical dimensions. The design, construction, and physical dimensions shall be as specified in MIL-M-38510 and herein.

3.2.1 Terminal connections. The terminal connections shall be as specified on figure 1.

3.2.2 Mode selection table. The mode selection table shall be specified on figure 2.

3.2.3 Functional diagram. The functional diagram shall be as specified on figure 3.

3.2.4 Case outline. The case outline shall be in accordance with 1.2.2 herein.

3.3 Electrical performance characteristics. Unless otherwise specified, the electrical performance characteristics are as specified in table I and apply over the full case operating temperature range.

3.4 Marking. Marking shall be in accordance with MIL-STD-883 (see 3.1 herein). The part shall be marked with the part number listed in 1.2 herein. In addition, the manufacturer's part number may also be marked as listed in 6.4 herein

3.5 Certificate of compliance. A certificate of compliance shall be required from a manufacturer in order to be listed as an approved source of supply in 6.4. The certificate of compliance submitted to DESC-ECS prior to listing as an approved source of supply shall state that the manufacturer's product meets the requirements of MIL-STD-883 (see 3.1 herein) and the requirements herein.

3.6 Certificate of conformance. A certificate of conformance as required in MIL-STD-883 (see 3.1 herein) shall be provided with each lot of microcircuits delivered to this drawing.

<b>STANDARDIZED MILITARY DRAWING</b> DEFENSE ELECTRONICS SUPPLY CENTER DAYTON, OHIO 45444	SIZE <b>A</b>		5962-88624
		REVISION LEVEL	SHEET 3

TABLE I. Electrical performance characteristics.

Test	Symbol	Conditions -55°C ≤ T <sub>C</sub> ≤ +125°C 1/	Group A subgroups	Limits		Unit
				Min	Max	
High level output voltage	V <sub>OH</sub>	V <sub>IN</sub> = V <sub>IH</sub> or V <sub>IL</sub> ,  I <sub>O</sub>   ≤ 20 μA	V <sub>CC</sub> = 4.5 V	1,2,3	4.4	V
		V <sub>IN</sub> = V <sub>IH</sub> or V <sub>IL</sub> ,  I <sub>O</sub>   ≤ 4.0 mA	V <sub>CC</sub> = 4.5 V	1,2,3	3.7	V
Low level output voltage	V <sub>OL</sub>	V <sub>IN</sub> = V <sub>IH</sub> or V <sub>IL</sub> ,  I <sub>O</sub>   ≤ 20 μA	V <sub>CC</sub> = 4.5 V	1,2,3	0.1	V
		V <sub>IN</sub> = V <sub>IH</sub> or V <sub>IL</sub> ,  I <sub>O</sub>   ≤ 4.0 mA	V <sub>CC</sub> = 4.5 V	1,2,3	0.4	V
High level input voltage	V <sub>IH</sub>	2/	V <sub>CC</sub> = 4.5 V	1,2,3	2.0	V
Low level input voltage	V <sub>IL</sub>	2/	V <sub>CC</sub> = 4.5 V	1,2,3	0.8	V
Quiescent current	I <sub>CC</sub>	V <sub>CC</sub> = 5.5 V, V <sub>IN</sub> = V <sub>CC</sub> or GND		1,2,3	160	μA
Input leakage current	I <sub>IN</sub>	V <sub>CC</sub> = 5.5 V, V <sub>IN</sub> = V <sub>CC</sub> or GND		1,2,3	±1	μA
Additional quiescent current	ΔI <sub>CC</sub>	V <sub>IN</sub> = 2.4 or 0.5 V, any 1 input V <sub>IN</sub> = V <sub>CC</sub> or GND, other inputs V <sub>CC</sub> = 5.5 V		1,2,3	3.0	mA
Input capacitance	C <sub>IN</sub>	V <sub>IN</sub> = 0 V, T <sub>C</sub> = +25°C, See 4.3.1c		4	10	pF
Functional tests		See 4.3.1d		7		
Maximum clock frequency 3/	f <sub>max</sub>	V <sub>CC</sub> = 4.5 V		9	25	MHz
				10,11	17	

See footnotes at end of table.

<b>STANDARDIZED MILITARY DRAWING</b> DEFENSE ELECTRONICS SUPPLY CENTER DAYTON, OHIO 45444	SIZE <b>A</b>		5962-88624
		REVISION LEVEL	SHEET 4

TABLE I. Electrical performance characteristics - Continued.

Test	Symbol	Conditions -55°C ≤ T <sub>C</sub> ≤ +125°C <u>1/</u>	Group A subgroups	Limits		Unit
				Min	Max	
Propagation delay time, LE and clock to output (see figure 4)	t <sub>PHL1</sub>	V <sub>CC</sub> = 5.0 V ±10%, CL = 50 pF ±10%	9		46	ns
	t <sub>PLH1</sub>		10,11		69	ns
Transition time <u>3/</u> (see figure 4)	t <sub>TLH</sub>		9		15	ns
	t <sub>THL</sub>		10,11		22	ns

1/ For a power supply of 5 V ±10 percent, the worst case output voltages (V<sub>OH</sub> and V<sub>OL</sub>) occur for HCT at 4.5 V. Thus, the 4.5 V values should be used when designing with this supply. Worst case V<sub>IH</sub> and V<sub>IL</sub> occur at V<sub>CC</sub> = 5.5 V and 4.5 V respectively.

2/ Test not required if applied as a forcing function for V<sub>OH</sub> or V<sub>OL</sub>.

3/ Guaranteed, if not tested, to the specified limits.

3.7 Notification of change. Notification of change to DESC-ECS shall be required in accordance with MIL-STD-883 (see 3.1 herein).

3.8 Verification and review. DESC, DESC's agent, and the acquiring activity retain the option to review the manufacturer's facility and applicable required documentation. Offshore documentation shall be made available onshore at the option of the reviewer.

4. QUALITY ASSURANCE PROVISIONS

4.1 Sampling and inspection. Sampling and inspection procedures shall be in accordance with section 4 of MIL-M-38510 to the extent specified in MIL-STD-883 (see 3.1 herein).

<b>STANDARDIZED MILITARY DRAWING</b> DEFENSE ELECTRONICS SUPPLY CENTER DAYTON, OHIO 45444	SIZE <b>A</b>		5962-88624
		REVISION LEVEL	SHEET 5

Device type	01
Package	J
Terminal number	Terminal symbol
1	CP
2	LE
3	J1
4	J2
5	J3
6	J4
7	J16
8	J15
9	J14
10	J13
11	K <sub>c</sub>
12	GND
13	K <sub>b</sub>
14	K <sub>a</sub>
15	J12
16	J11
17	J10
18	J9
19	J8
20	J7
21	J6
22	J5
23	Q
24	V <sub>CC</sub>

FIGURE 1. Terminal connections.

<b>STANDARDIZED MILITARY DRAWING</b> DEFENSE ELECTRONICS SUPPLY CENTER DAYTON, OHIO 45444	SIZE <b>A</b>	5962-88624
	REVISION LEVEL	SHEET 6

Device type 01

Mode select input 1/, 4/			First counting section			Last counting section			Counter range	
									Design	Extended
K <sub>a</sub>	K <sub>b</sub>	K <sub>c</sub>	Mode	Can be preset to a	Jam inputs used 2/	Mode	Can be preset to a	Jam inputs used 2/	Max	Max
			Divides by	max of		Divides by	max of			
H	H	H	2	1	J1	8	7	J2, J3, J4	15,999	17,331
L	H	H	4	3	J1, J2	4	3	J3, J4	15,999	18,663
H	L	H	5 3/	4	J1, J2, J3	2	1	J4	9,999	13,329
L	L	H	8	7	J1, J2, J3	2	1	J4	15,999	21,327
H	H	L	10	9	J1, J2, J3, J4	1	0	--	9,999	16,659
X	L	L	Master preset			Master preset			---	---

1/ H = High level (steady state)  
 L = Low level (steady state)  
 X = Don't care

2/ J1 = Least significant bit  
 J4 = Most significant bit

3/ Operation in the divide by 5 mode (1st counting section) requires going through the master preset mode prior to going into the divide by 5 mode. At power turn-on, K<sub>c</sub> must be "low" for a period of 3 input clock pulses after V<sub>CC</sub> reaches a minimum of 3 volts.

4/ LE (High) = output disabled (output = high)  
 LE (Low) = output enabled after one cycle

FIGURE 2. Mode selection table.

<b>STANDARDIZED                  MILITARY DRAWING</b> DEFENSE ELECTRONICS SUPPLY CENTER DAYTON, OHIO 45444	SIZE <b>A</b>	5962-88624
		REVISION LEVEL

How to preset the 54/HCT4059 to desired ÷ N

The value N is determined as follows:

$$N = (\text{MODE}^*) (1000 \times \text{decade 5 preset} + 100 \times \text{decade 4 preset} + 10 \times \text{decade 3 preset} + 1 \times \text{decade 2 preset}) + \text{decade 1 preset}$$

\*MODE = First counting section divider (10, 8, 5, 4, or 2)

To calculate preset values for any N count, divide the N count by the mode. The resultant is the corresponding preset values of the 5th through 2nd decade with the remainder being equal to the 1st decade value.

$$\text{Preset value} = \frac{N}{\text{Mode}}$$

Example:

$$N = 8479, \text{ Mode} = 5$$

$$\text{Mode select} = 5$$

$K_a$	$K_b$	$K_c$
H	L	H

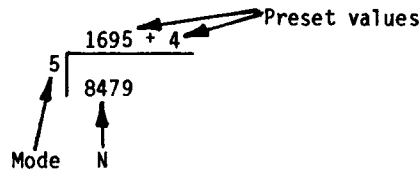

Program jam inputs (BCD)

<u>4</u>			<u>1</u>	<u>5</u>				<u>9</u>				<u>6</u>			
J1	J2	J3	J4	J5	J6	J7	J8	J9	J10	J11	J12	J13	J14	J15	J16
L	L	H	H	H	L	H	L	H	L	L	H	L	H	H	L

To verify the results, use equation 1:

$$N = 5 (1000 \times 1 + 100 \times 6 + 10 \times 9 + 1 \times 5) + 4$$

$$N = 8479$$

FIGURE 2. Mode selection table - Continued.

<b>STANDARDIZED MILITARY DRAWING</b> DEFENSE ELECTRONICS SUPPLY CENTER DAYTON, OHIO 45444	SIZE <b>A</b>	5962-88624
	REVISION LEVEL	SHEET 8



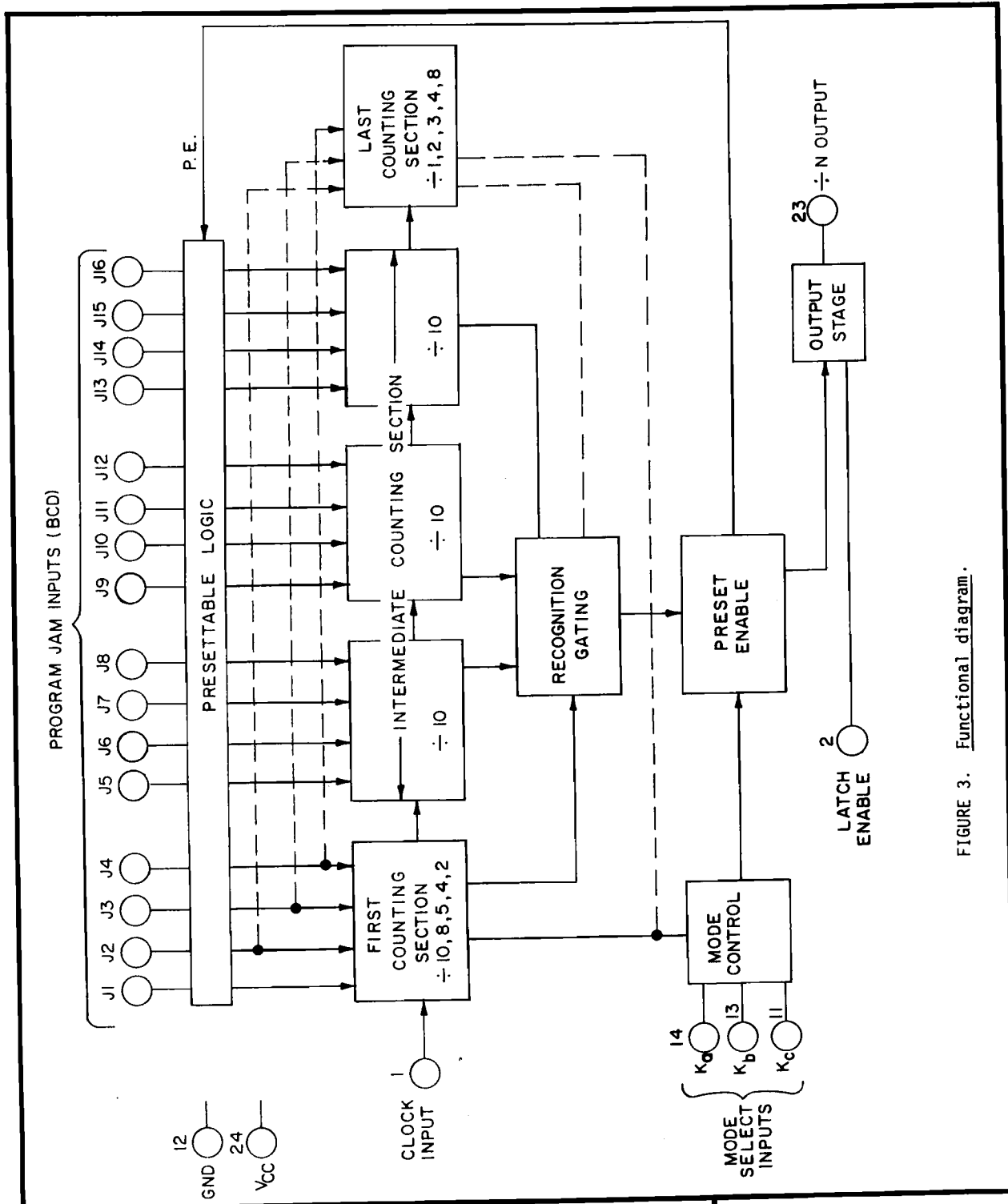

FIGURE 3. Functional diagram.

<b>STANDARDIZED MILITARY DRAWING</b> DEFENSE ELECTRONICS SUPPLY CENTER DAYTON, OHIO 45444	SIZE <b>A</b>	5962-88624
	REVISION LEVEL	SHEET 9

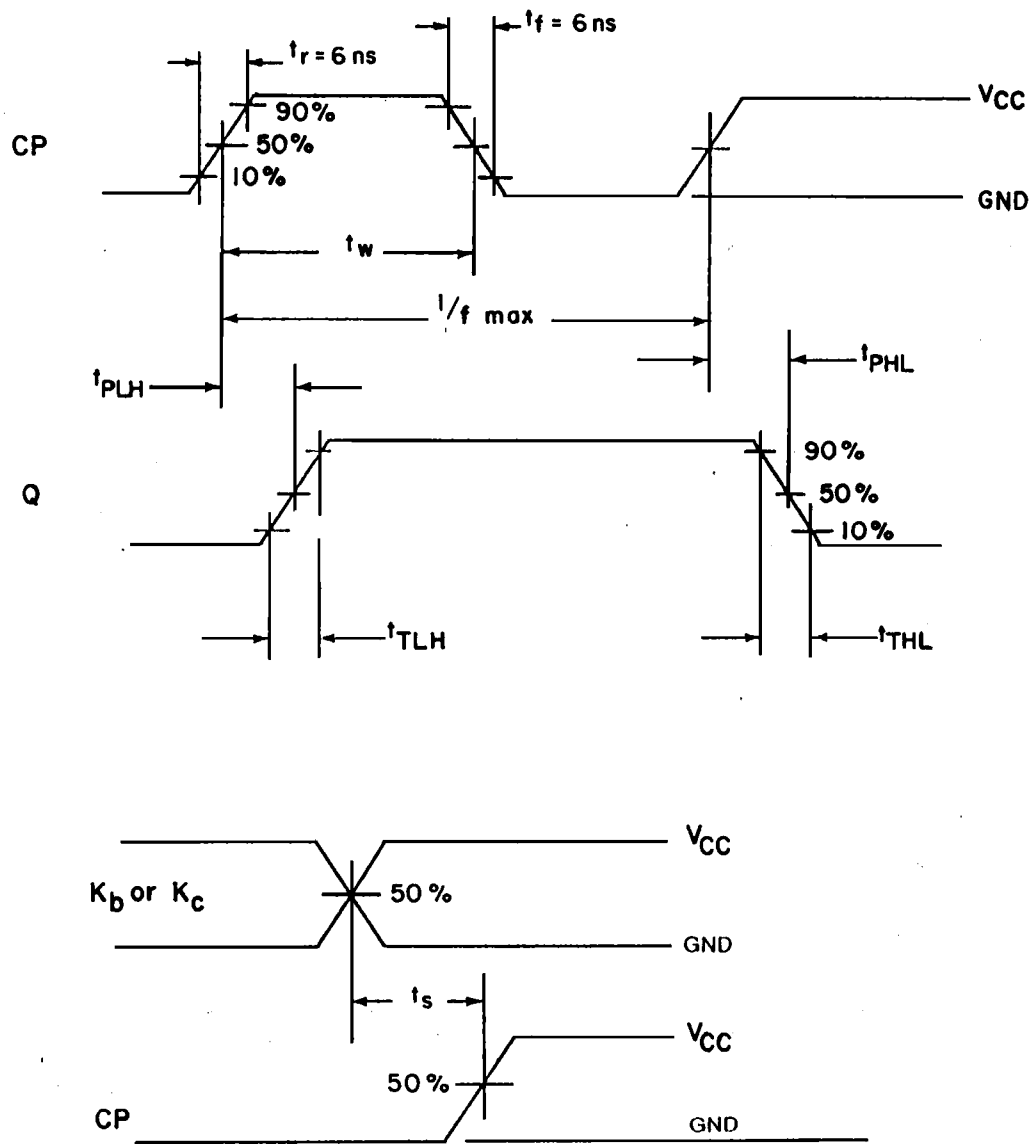

FIGURE 4. Switching waveforms.

<b>STANDARDIZED MILITARY DRAWING</b> DEFENSE ELECTRONICS SUPPLY CENTER DAYTON, OHIO 45444	SIZE <b>A</b>	5962-88624
	REVISION LEVEL	SHEET 10

4.2 Screening. Screening shall be in accordance with method 5004 of MIL-STD-883, and shall be conducted on all devices prior to quality conformance inspection. The following additional criteria shall apply:

- a. Burn-in test method 1015 of MIL-STD-883.
  - (1) Test condition A, B, C, or D using the circuit submitted with the certificate of compliance (see 3.5 herein).
  - (2)  $T_A = +125^{\circ}\text{C}$ , minimum.
- b. Interim and final electrical test parameters shall be as specified in table II herein, except interim electrical parameter tests prior to burn-in are optional at the discretion of the manufacturer.

4.3 Quality conformance inspection. Quality conformance inspection shall be in accordance with method 5005 of MIL-STD-883 including groups A, B, C, and D inspections. The following additional criteria shall apply.

4.3.1 Group A inspection.

- a. Tests shall be as specified in table II herein.
- b. Subgroups 5, 6, and 8 in table I, method 5005 of MIL-STD-883 shall be omitted.
- c. Subgroup 4 ( $C_{IN}$  measurement) shall be measured only for the initial test and after process or design changes which may affect input capacitance.
- d. Subgroup 7 test sufficient to verify all 16 JAM inputs to truth table using all 5 modes. Function testing at  $f_{max}$  shall be done for initial test and after process or design changes which may affect the functionality of the device.

4.3.2 Groups C and D inspections.

- a. End-point electrical parameters shall be as specified in table II herein.
- b. Steady-state life test method 1005 of MIL-STD-883 conditions:
  - (1) Test condition A, B, C, or D using the circuit submitted with the certificate of compliance (see 3.5 herein).
  - (2)  $T_A = +125^{\circ}\text{C}$ , minimum.
  - (3) Test duration: 1,000 hours, except as permitted by method 1005 of MIL-STD-883.

<b>STANDARDIZED MILITARY DRAWING</b> DEFENSE ELECTRONICS SUPPLY CENTER DAYTON, OHIO 45444	SIZE <b>A</b>	5962-88624
	REVISION LEVEL	SHEET 11

TABLE II. Electrical test requirements.

MIL-STD-883 test requirements	Subgroups (per method 5005, table I)
Interim electrical parameters (method 5004)	---
Final electrical test parameters (method 5004)	1*,2,9
Group A test requirements (method 5005)	1,2,3,4,7, 9,10,11
Groups C and D end-point electrical parameters (method 5005)	1,2,3

\* PDA applies to subgroup 1.

5. PACKAGING

5.1 Packaging requirements. The requirements for packaging shall be in accordance with MIL-M-38510.

6. NOTES

6.1 Intended use. Microcircuits conforming to this drawing are intended for use when military specifications do not exist and qualified military devices that will perform the required function are not available for OEM application. When a military specification exists and the product covered by this drawing has been qualified for listing on QPL-38510, the device specified herein will be inactivated and will not be used for new design. The QPL-38510 product shall be the preferred item for all applications.

6.2 Replaceability. Microcircuits covered by this drawing will replace the same generic device covered by a contractor-prepared specification or drawing.

6.3 Comments. Comments on this drawing should be directed to DESC-ECS, Dayton, Ohio 45444, or telephone 513-296-5375.

<b>STANDARDIZED MILITARY DRAWING</b> DEFENSE ELECTRONICS SUPPLY CENTER DAYTON, OHIO 45444	SIZE <b>A</b>	5962-88624
	REVISION LEVEL	SHEET 12

6.4 Approved source of supply. An approved source of supply is listed herein. Additional sources will be added as they become available. The vendor listed herein has agreed to this drawing and a certificate of compliance (see 3.5 herein) has been submitted to DESC-ECS.

Military drawing part number	Vendor CAGE number	Vendor similar part number <u>1/</u>
5962-8862401JX	18714	CD54HCT4059F/3A

1/ Caution. Do not use this number for item acquisition. Items acquired by this number may not satisfy the performance requirements of this drawing.

Vendor CAGE number

18714

Vendor name and address

GE/RCA Corporation  
Route 202  
Somerville, NJ 08876

<b>STANDARDIZED MILITARY DRAWING</b> DEFENSE ELECTRONICS SUPPLY CENTER DAYTON, OHIO 45444	SIZE <b>A</b>		5962-88624
		REVISION LEVEL	SHEET 13