

March 1997

## CMOS Octal Latching Inverting Bus Driver

### Features

- Full 8-Bit Parallel Latching Buffer
- Bipolar 8283 Compatible
- Three-State Inverting Outputs
- Propagation Delay ..... 25ns Max
- Gated Inputs
  - Reduce Operating Power
  - Eliminate the Need for Pull-Up Resistors
- Single 5V Power Supply
- Low Power Operation
  - ICCSB ..... 10mA
- Operating Temperature Ranges
  - C82C83H ..... 0°C to +70°C
  - I82C83H ..... -40°C to +85°C
  - M82C83H ..... -55°C to +125°C

### Description

The Harris 82C83H is a high performance CMOS Octal Latching Buffer manufactured using a self-aligned silicon gate CMOS process (Scaled SAJI IV). The 82C83H provides an 8-bit parallel latch/buffer in a 20 lead pin package. The active high strobe (STB) input allows transparent transfer of data and latches data on the negative transition of this signal. The active low output enable (OE) permits simple interface to microprocessor systems. The 82C83H provides inverted data at the outputs.

### Ordering Information

PART NO.	PACKAGE	TEMP RANGE	PKG. NO
CP82C83H	20 Ld PDIP	0°C to +70°C	E20.3
IP82C83H		-40°C to +85°C	E20.3
CS82C83H	20 Ld PLCC	0°C to +70°C	N20.35
IS82C83H		-40°C to +85°C	N20.35
CD82C83H	20 Ld Cerdip	0°C to +70°C	F20.3
ID82C83H		-40°C to +85°C	F20.3
MD82C83H/B		0°C to +70°C	F20.3
8406702RA	SMD#	-55°C to +125°C	F20.3
MR82C83H/B	20 Pad CLCC	-55°C to +125°C	J20.A
84067022A	SMD#	-55°C to +125°C	J20.A

### Pinouts

82C83H (PDIP, Cerdip)  
TOP VIEW

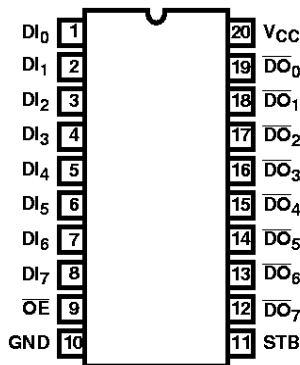

82C83H (PLCC, CLCC)  
TOP VIEW

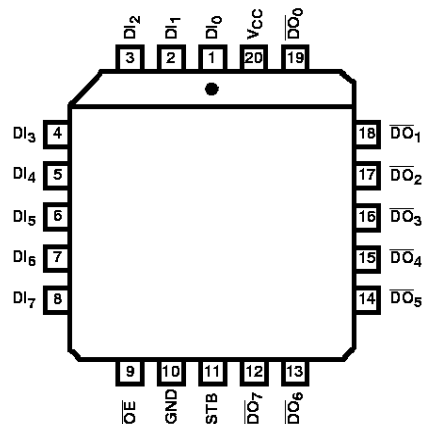

### TRUTH TABLE

STB	OE	DI	DO
X	H	X	HI-Z
H	L	L	H
H	L	H	L
↓	L	X	†

H = Logic One  
L = Logic Zero  
X = Don't Care  
HI-Z = High Impedance  
↓ = Negative Transition  
† = Latched to Value of Last Data

### PIN NAMES

PIN	DESCRIPTION
DI <sub>0</sub> - DI <sub>7</sub>	Data Input Pins
DO <sub>0</sub> - DO <sub>7</sub>	Data Output Pins
STB	Active High Strobe
OE	Active Low Output Enable

**Functional Diagram**

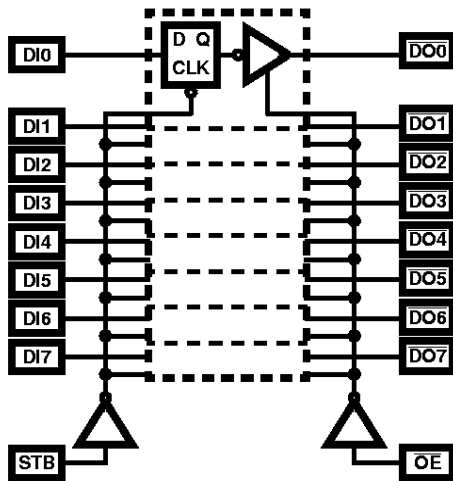

**Gated Inputs**

During normal system operation of a latch, signals on the bus at the device inputs will become high impedance or make transitions unrelated to the operation of the latch. These unrelated input transitions switch the input circuitry and typically cause an increase in power dissipation in CMOS devices by creating a low resistance path between  $V_{CC}$  and GND when the signal is at or near the input switching threshold. Additionally, if the driving signal becomes high impedance ("float" condition), it could create an indeterminate logic state at the inputs and cause a disruption in device operation.

The Harris 82C8X series of bus drivers eliminates these conditions by turning off data inputs when data is latched (STB = logic zero for the 82C82/83H) and when the device is disabled (OE = logic one for the 82C86H/87H). These gated inputs disconnect the input circuitry from the  $V_{CC}$  and ground power supply pins by turning off the upper P-channel and lower N-channel (See Figures 1 and 2). No current flow from  $V_{CC}$  to GND occurs during input transitions and invalid logic states from floating inputs are not transmitted. The next stage is held to a valid logic level internal to the device.

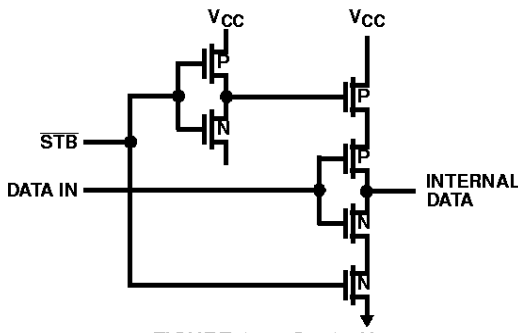

FIGURE 1. 82C82/83H

D.C. input voltage levels can also cause an increase in  $I_{CC}$  if these input levels approach the minimum  $V_{IH}$  or maximum  $V_{IL}$  conditions. This is due to the operation of the input circuitry in its linear operating region (partially conducting

state). The 82C8X series gated inputs mean that this condition will occur only during the time the device is in the transparent mode (STB = logic one).  $I_{CC}$  remains below the maximum  $I_{CC}$  standby specification of  $10\mu A$  during the time inputs are disabled, thereby greatly reducing the average power dissipation of the 82C8X series devices.

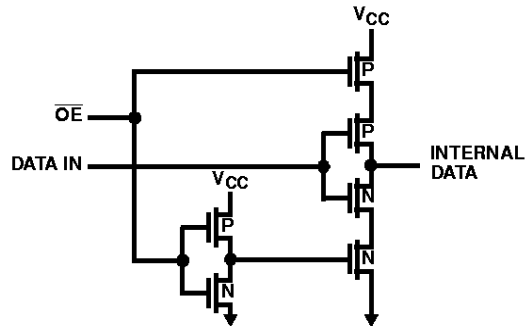

FIGURE 2. 82C86H/87H GATED INPUTS

**Decoupling Capacitors**

The transient current required to charge and discharge the 300pF load capacitance specified in the 82C83H data sheet is determined by

$$I = C_L (dv/dt)$$

Assuming that all outputs change state at the same time and that  $dv/dt$  is constant;

$$I = C_L \frac{(V_{CC} \times 80 \text{ percent})}{t_R/t_F} \quad \text{(EQ. 1)}$$

where  $t_R = 20ns$ ,  $V_{CC} = 5.0V$ ,  $C_L = 300pF$  on each eight outputs.

$$I = (8 \times 300 \times 10^{-12}) \times (5.0V \times 0.8) / (20 \times 10^{-9}) = 480mA$$

This current spike may cause a large negative voltage spike on  $V_{CC}$  which could cause improper operation of the device. To filter out this noise, it is recommended that a  $0.1\mu F$  ceramic disc capacitor be placed between  $V_{CC}$  and GND at each device, with placement being as near to the device as possible.

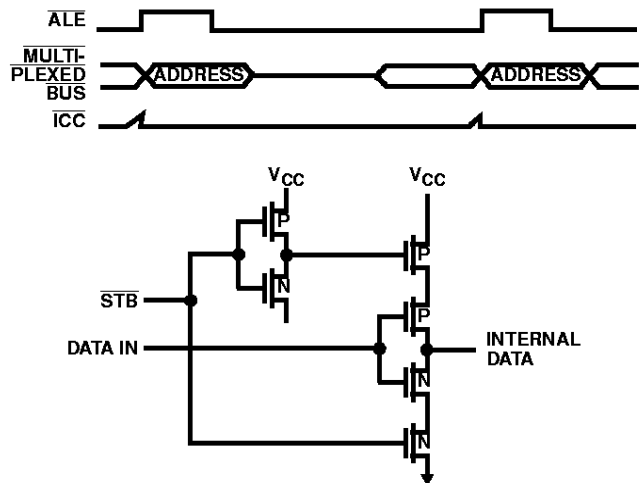

FIGURE 3. SYSTEM EFFECTS OF GATED INPUTS

# 82C83H

## Absolute Maximum Ratings

Supply Voltage ..... +8.0V  
 Input, Output or I/O Voltage ..... GND 0.5V to  $V_{CC} + 0.5V$   
 ESD Classification ..... Class 1

## Operating Conditions

Operating Voltage Range ..... +4.5V to +5.5V  
 Operating Temperature Range  
 C82C83H ..... 0°C to +70°C  
 I82C83H ..... -40°C to +85°C  
 M82C83H ..... -55°C to +125°C

## Thermal Information

Thermal Resistance (Typical)	$\theta_{JA}$ °C/W	$\theta_{JC}$ °C/W
CERDIP Package	70	16
CLCC Package	80	20
PDIP Package	75	N/A
PLCC Package	75	N/A
Storage Temperature Range	-65°C to +150°C	
Max Junction Temperature Ceramic Package	+175°C	
Max Junction Temperature Plastic Package	+150°C	
Lead Temperature (Soldering 10s) (PLCC - Lead Tips Only)	+300°C	

## Die Characteristics

Gate Count ..... 265 Gates

*CAUTION: Stresses above those listed in "Absolute Maximum Ratings" may cause permanent damage to the device. This is a stress only rating and operation of the device at these or any other conditions above those indicated in the operational sections of this specification is not implied.*

**DC Electrical Specifications**  $V_{CC} = 5.0V \pm 10\%$ ;  $T_A = 0^\circ C$  to +70°C (C82C83H);  
 $T_A = -40^\circ C$  to +85°C (I82C83H);  
 $T_A = -55^\circ C$  to +125°C (M82C83H)

SYMBOL	PARAMETER	MIN	MAX	UNITS	TEST CONDITIONS
$V_{IH}$	Logical One Input Voltage	2.0 2.2	-	V	C82C83H, I82C83H, M82C83H, (Note 1)
$V_{IL}$	Logical Zero Input Voltage		0.8	V	
$V_{OH}$	Logical One Output Voltage	3.0 $V_{CC} - 0.4V$	-	V	$I_{OH} = -8mA$ , $I_{OH} = -100mA$ , $\overline{OE} = GND$
$V_{OL}$	Logical Zero Output Voltage		0.45	V	$I_{OL} = 20mA$ , $\overline{OE} = GND$
$I_I$	Input Leakage Current	-10	10	$\mu A$	$V_{IN} = GND$ or $V_{CC}$ , DIP Pins 1-9,11
$I_O$	Output Leakage Current	-10	10	$\mu A$	$V_O = GND$ or $\overline{OE} \geq V_{CC} - 0.5V$ DIP Pins 12-19
ICCSB	Standby Power Supply Current	-	10	$\mu A$	$V_{IN} = V_{CC}$ or GND $V_{CC} = 5.5V$ Outputs Open
IC COP	Operating Power Supply Current	-	1	mA/ MHz	$T_A = +25^\circ C$ , $V_{CC} = 5V$ , Typical (See Note 2)

### NOTES:

- $V_{IH}$  is measured by applying a pulse of magnitude =  $V_{IHMIN}$  to one data input at a time and checking the corresponding device output for a valid logical 1 - during valid input high time. Control pins (STB,  $\overline{CE}$ ) are tested separately with all device data input pins at  $V_{CC} - 0.4V$ .
- Typical ICCOP = 1 mA/MHz of STB cycle time. (Example: 5MHz  $\mu P$ , ALE = 1.25MHz, ICCOP = 1.25mA).

## Capacitance $T_A = +25^\circ C$

SYMBOL	PARAMETER	TYPICAL	UNITS	TEST CONDITIONS
$C_{IN}$	Input Capacitance	13	pF	FREQ = 1MHz, all measurements are referenced to device GND
$C_{OUT}$	Output Capacitance	20	pF	

## 82C83H

**AC Electrical Specifications**  $V_{CC} = 5.0V \pm 10\%$ ;  $C_L = 300pF$  (Note 1),  $FREQ = 1MHz$   
 $T_A = 0^\circ C$  to  $+70^\circ C$  (C82C83H);  
 $T_A = -40^\circ C$  to  $+85^\circ C$  (I82C83H);  
 $T_A = -55^\circ C$  to  $+125^\circ C$  (M82C83H)

SYMBOL	PARAMETER	LIMITS		UNITS	TEST CONDITIONS
		MIN	MAX		
(1) TIVOV	Propagation Delay Input to Output	5	25	ns	See Notes 2, 3
(2) TSHOV	Propagation Delay STB to Output	10	50	ns	See Notes 2, 3
(3) TEHOZ	Output Disable Time	5	22	ns	See Notes 2, 3
(4) TELOV	Output Enable Time	10	45	ns	See Notes 2, 3
(5) TIVSL	Input to STB Set Up Time	0	-	ns	See Notes 2, 3
(6) TSLIX	Input to STB Hold Time	30	-	ns	See Notes 2, 3
(7) TSHSL	STB High Time	15	-	ns	See Notes 2, 3
(8) TR, TF	Input Rise/Fall Times	-	20	ns	See Notes 2, 3

**NOTES:**

- Output load capacitance is rated 300pF for both ceramic and plastic packages.
- All AC Parameters tested as per test load circuits. Input rise and fall times are driven at 1ns/V.
- Input test signals must switch between  $V_{IL} - 0.4V$  and  $V_{IH} + 0.4V$ .

### Timing Waveforms

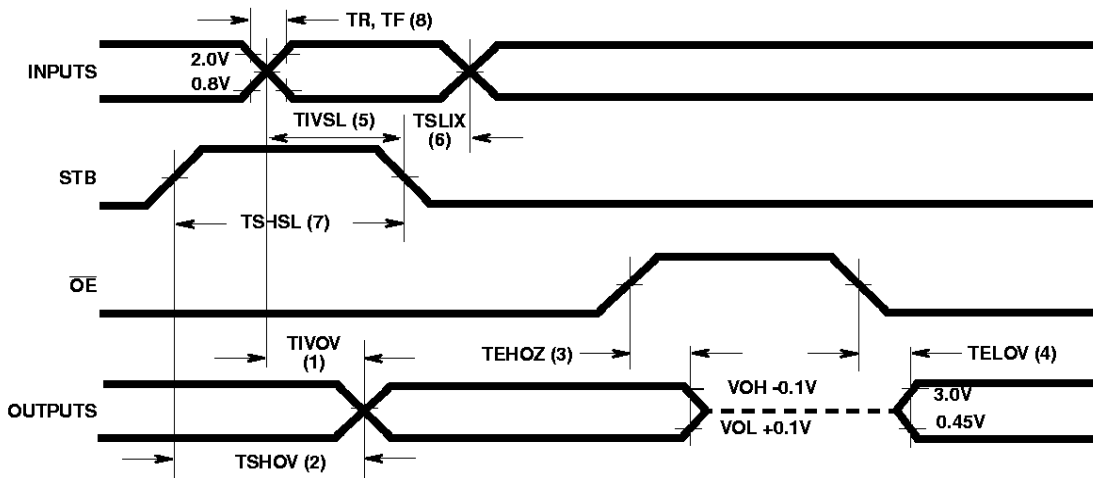

All Timing measurements are made at 1.5V unless otherwise noted.

FIGURE 4. TIMING WAVEFORMS

### Test Load Circuits

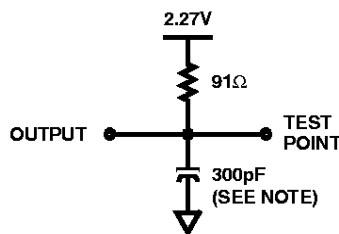

FIGURE 5. TIVOV, TSHOV

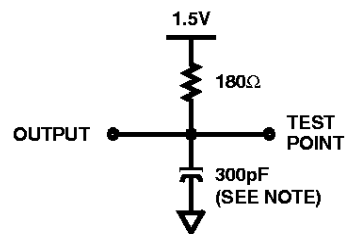
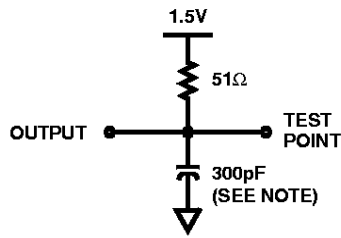

FIGURE 6. TELOV OUTPUT HIGH ENABLE

**Test Load Circuits** (Continued)



NOTE: Includes jig and stray capacitance.

FIGURE 7. TELOV OUTPUT LOW ENABLE

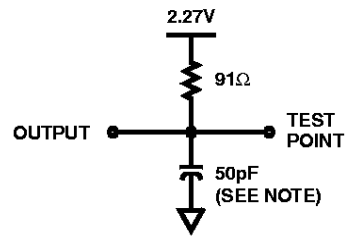

FIGURE 8. TEHOZ OUTPUT LOW/HIGH DISABLE

**Burn-In Circuits**

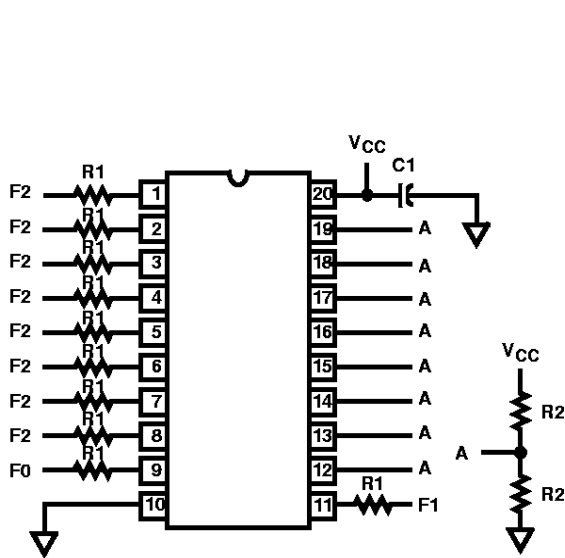

FIGURE 9. MD82C83H CERDIP

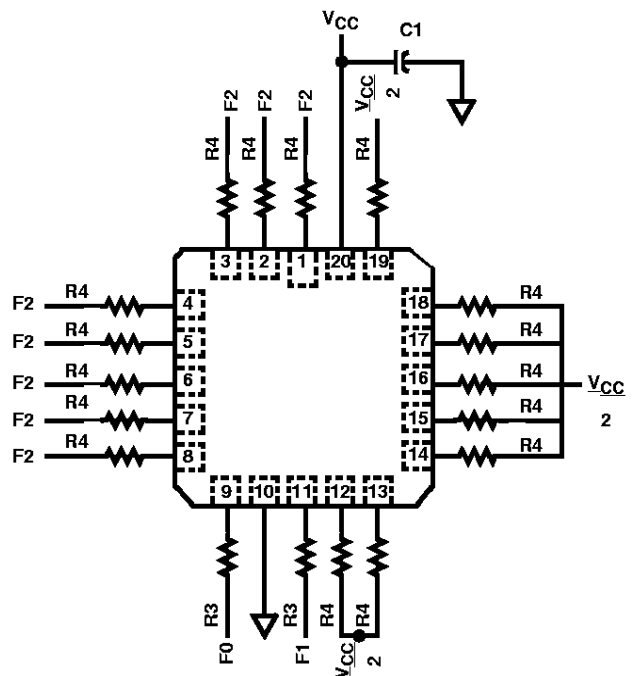

FIGURE 10. MR82C83H CLCC

NOTES:

1.  $V_{CC} = 5.5V \pm 0.5V$  GND = 0V
2.  $V_{IH} = 4.5V \pm 10\%$
3.  $V_{IL} = -0.2$  to  $0.4V$
4.  $R1 = 47k\Omega \pm 5\%$
5.  $R2 = 2.0k\Omega \pm 5\%$
6.  $R3 = 1.0k\Omega \pm 5\%$
7.  $R4 = 5.0k\Omega \pm 5\%$
8.  $C1 = 0.01\mu F$  Minimum
9.  $F0 = 100kHz \pm 10\%$
10.  $F1 = F0/2$ ,  $F2 = F1/2$ ,  $F3 = F2/2$

# 82C83H

## Die Characteristics

**DIE DIMENSIONS:**  
138.6 x 155.5 x 19 ± 1 mils

**METALLIZATION:**  
Type: Silicon - Aluminum  
Thickness: 11kÅ ± 2kÅ

**GLASSIVATION:**  
Type: SiO<sub>2</sub>  
Thickness: 8kÅ ± 1kÅ

**WORST CASE CURRENT DENSITY:**  
2.0 x 10<sup>5</sup> A/cm<sup>2</sup>

## Metallization Mask Layout

82C83H

