

## 3-MODE 150mA LDO REGULATOR

NO.EA-110-130415

### OUTLINE

The R1162x Series consist of CMOS-based voltage regulator ICs with high output voltage accuracy and low supply current. Each of these voltage regulator ICs consists of a voltage reference unit, an error amplifier, resistors for setting output voltage, a current limit circuit, and so on. The output voltage is internally fixed with high accuracy.

These ICs perform with the chip enable function and realize a standby mode with ultra low supply current. To prevent the destruction by over current, the current limit circuit is included. The R1162x Series have 3-mode. One is standby mode with CE or standby control pin. Other two modes are realized with ECO pin. Fast Transient Mode (FT mode) and Low Power Mode (LP mode) are alternative with ECO pin. Consumption current is reduced at Low Power Mode compared with Fast Transient Mode. The output voltage is maintained between FT mode and LP mode.

Since the packages for these ICs are SOT-23-5 and SON1612-6 packages, high density mounting of the ICs on boards is possible.

### FEATURES

- Supply Current ..... Typ. 5.5 $\mu$ A (Low Power Mode),  
Typ. 70 $\mu$ A (Fast Transient Mode)
- Standby Current ..... Typ. 0.1 $\mu$ A
- High Ripple Rejection ..... Typ. 70dB (f=1kHz, Fast Transient Mode)  
Typ. 60dB (f=10kHz, Fast Transient Mode)
- Input Voltage Range ..... 2.0V to 6.0V
- Output Voltage Range..... 1.5V to 4.0V (0.1V steps)  
(For other voltages, please refer to MARK INFORMATION.)
- Output Voltage Accuracy..... $\pm$ 2.0% ( $\pm$ 3.0% at Low Power Mode)
- Temperature-Drift Coefficient of Output Voltage .... Typ.  $\pm$ 100ppm/ $^{\circ}$ C
- Dropout Voltage ..... Typ. 0.25V (I<sub>OUT</sub>=150mA , V<sub>OUT</sub>=2.8V)
- Line Regulation ..... Typ. 0.02%/V
- Package ..... SON1612-6, SOT-23-5
- Built-in fold-back protection circuit ..... Typ. 40mA (Current at short mode)
- Performs with Ceramic Capacitors ..... C<sub>IN</sub>=1.0 $\mu$ F, C<sub>OUT</sub>=0.47 $\mu$ F

### APPLICATIONS

- Precision Voltage References.
- Power source for electrical appliances such as cameras, VCRs and hand-held communication equipment.
- Power source for battery-powered equipment.

## BLOCK DIAGRAM

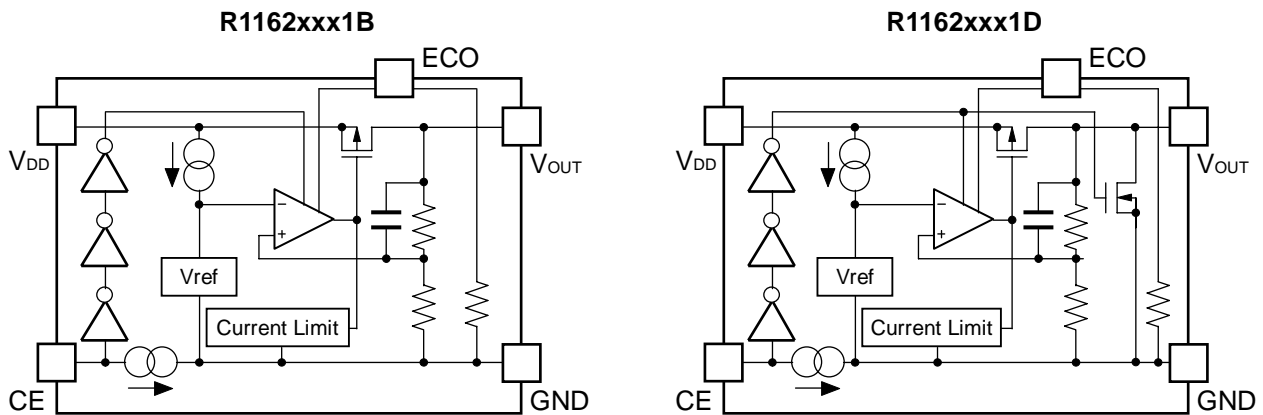

## SELECTION GUIDE

The output voltage, auto discharge function, and package, etc. for the ICs can be selected at the user's request.

Product Name	Package	Quantity per Reel	Pb Free	Halogen Free
R1162Dxx1*-TR-FE	SON1612-6	4,000 pcs	Yes	Yes
R1162Nxx1*-TR-FE	SOT-23-5	3,000 pcs	Yes	Yes

xx: The output voltage can be designated in the range from 1.5V(15) to 4.0V(40) in 0.1V steps.  
(For other voltages, please refer to MARK INFORMATIONS.)

\* : The auto discharge function at off state are options as follows.  
(B) without auto discharge function at off state  
(D) with auto discharge function at off state

## PIN CONFIGURATIONS

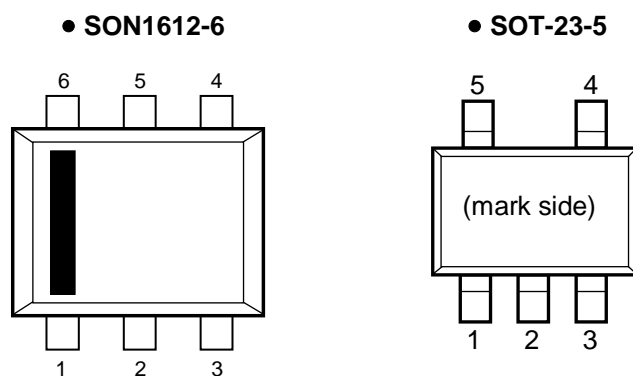

## PIN DESCRIPTIONS

### • SON1612-6

Pin No	Symbol	Pin Description
1	CE	Chip Enable Pin ("H" Active)
2	GND	Ground Pin
3	V <sub>DD</sub>	Input Pin
4	V <sub>OUT</sub>	Output Pin
5	GND	Ground Pin
6	ECO	MODE alternative pin

### • SOT-23-5

Pin No	Symbol	Pin Description
1	V <sub>DD</sub>	Input Pin
2	GND	Ground Pin
3	CE	Chip Enable Pin ("H" Active)
4	ECO	MODE alternative pin
5	V <sub>OUT</sub>	Output pin

## ABSOLUTE MAXIMUM RATINGS

Symbol	Item	Rating	Unit
$V_{IN}$	Input Voltage	6.5	V
$V_{ECO}$	Input Voltage (ECO Pin)	-0.3 to 6.5	V
$V_{CE}$	Input Voltage ( $\overline{CE}$ / CE Pin)	-0.3 to 6.5	V
$V_{OUT}$	Output Voltage	-0.3 to $V_{IN}+0.3$	V
$I_{OUT}$	Output Current	180	mA
$P_D$	Power Dissipation (SOT-23-5) *	420	mW
	Power Dissipation (SON1612-6)*	500	MW
$T_{opt}$	Operating Temperature Range	-40 ~ 85	°C
$T_{stg}$	Storage Temperature Range	-55 ~ 125	°C

\*) For Power Dissipation, please refer to PACKAGE INFORMATION.

### ABSOLUTE MAXIMUM RATINGS

Electronic and mechanical stress momentarily exceeded absolute maximum ratings may cause the permanent damages and may degrade the life time and safety for both device and system using the device in the field.

The functional operation at or over these absolute maximum ratings is not assured.

### RECOMMENDED OPERATING CONDITIONS (ELECTRICAL CHARACTERISTICS)

All of electronic equipment should be designed that the mounted semiconductor devices operate within the recommended operating conditions. The semiconductor devices cannot operate normally over the recommended operating conditions, even if when they are used over such conditions by momentary electronic noise or surge. And the semiconductor devices may receive serious damage when they continue to operate over the recommended operating conditions.

## ELECTRICAL CHARACTERISTICS

### • R1162xxx1B/D

T<sub>opt</sub>=25°C

Symbol	Item	Conditions	Min.	Typ.	Max.	Unit
V <sub>OUT</sub>	Output Voltage	V <sub>IN</sub> = Set V <sub>OUT</sub> +1V V <sub>ECO</sub> = V <sub>IN</sub> 1mA ≤ I <sub>OUT</sub> ≤ 30mA <sup>Note 1</sup>	V <sub>OUT</sub> ×0.98		V <sub>OUT</sub> ×1.02	V
		V <sub>IN</sub> = Set V <sub>OUT</sub> + 1V V <sub>ECO</sub> =GND 1mA ≤ I <sub>OUT</sub> ≤ 30mA <sup>Note 2</sup>	V <sub>OUT</sub> ×0.97		V <sub>OUT</sub> ×1.03	V
ΔV <sub>OUT</sub>	Output Voltage Deviation between FT Mode and LP Mode	V <sub>IN</sub> = Set V <sub>OUT</sub> +1V, I <sub>OUT</sub> =30mA V <sub>OUT</sub> ≤ 2.0V	-1.2	0.0	1.2	%
		V <sub>OUT</sub> ≥ 2.0V	(-24)	0.0	(24)	mV
I <sub>OUT</sub>	Output Current	V <sub>IN</sub> - V <sub>OUT</sub> = 1.0V	150			mA
ΔV <sub>OUT</sub> / ΔI <sub>OUT</sub>	Load Regulation(FT Mode)	V <sub>IN</sub> =Set V <sub>OUT</sub> +1V, V <sub>ECO</sub> =V <sub>IN</sub> 1mA ≤ I <sub>OUT</sub> ≤ 150mA		20	40	mV
	Load Regulation(LP Mode)	V <sub>IN</sub> = Set V <sub>OUT</sub> +1V, V <sub>ECO</sub> =GND 1mA ≤ I <sub>OUT</sub> ≤ 150mA		20	45	mV
V <sub>DIF</sub>	Dropout Voltage	Refer to the ELECTRICAL CHARACTERISTICS by OUTPUT VOLTAGE				
I <sub>SS1</sub>	Supply Current(FT Mode)	V <sub>IN</sub> = Set V <sub>OUT</sub> +1V V <sub>ECO</sub> = V <sub>IN</sub> , I <sub>OUT</sub> =0mA		70	100	μA
I <sub>SS2</sub>	Supply Current(LP Mode)	V <sub>IN</sub> = Set V <sub>OUT</sub> +1V V <sub>ECO</sub> = GND, I <sub>OUT</sub> =0mA		5.5	9.0	μA
I <sub>standby</sub>	Supply Current (Standby)	V <sub>IN</sub> = V <sub>CE</sub> = Set V <sub>OUT</sub> +1V		0.1	1.0	μA
ΔV <sub>OUT</sub> / ΔV <sub>IN</sub>	Line Regulation(FT Mode)	Set V <sub>OUT</sub> +0.5V ≤ V <sub>IN</sub> ≤ 6.0V I <sub>OUT</sub> = 30mA, V <sub>ECO</sub> = V <sub>IN</sub> V <sub>OUT</sub> ≤ 1.6V; 2.2V ≤ V <sub>IN</sub> ≤ 6.0V		0.02	0.10	%/V
	Line Regulation(LP Mode)	Set V <sub>OUT</sub> + 0.5V ≤ V <sub>IN</sub> ≤ 6.0V I <sub>OUT</sub> = 30mA, V <sub>ECO</sub> = GND V <sub>OUT</sub> ≤ 1.6V; 2.2V ≤ V <sub>IN</sub> ≤ 6.0V		0.05	0.20	%/V
RR	Ripple Rejection(FT Mode)	f = 1kHz f = 10kHz, Ripple 0.2Vp-p V <sub>IN</sub> = Set V <sub>OUT</sub> + 1V I <sub>OUT</sub> = 30mA, V <sub>ECO</sub> = V <sub>IN</sub>		70 60		dB
V <sub>IN</sub>	Input Voltage		2.0		6.0	V
ΔV <sub>OUT</sub> / ΔT <sub>opt</sub>	Output Voltage Temperature Coefficient	I <sub>OUT</sub> = 30mA -40°C ≤ T <sub>opt</sub> ≤ 85°C		±100		ppm /°C
I <sub>SC</sub>	Short Current Limit	V <sub>OUT</sub> = 0V		40		mA
I <sub>PD</sub>	CE Pull-down Constant Current			0.3	0.6	μA
R <sub>PD</sub>	ECO Pull-down Resistance		2	5	30	MΩ
V <sub>CEH</sub>	CE, ECO Input Voltage "H"		1.0		6.0	V
V <sub>CEL</sub>	CE, ECO Input Voltage "L"		0.00		0.35	V
e <sub>n</sub>	Output Noise (Fast Mode)	BW = 10Hz to 100kHz		30		μVrms
e <sub>n</sub>	Output Noise (Low Power Mode)	BW = 10Hz to 100kHz		40		μVrms
R <sub>LOW</sub>	Nch On resistance for auto-discharge (Applied to D version)	V <sub>CE</sub> =0V		60		Ω

## ELECTRICAL CHARACTERISTICS by OUTPUT VOLTAGE

T<sub>opt</sub> = 25°C

Output Voltage V <sub>OUT</sub> (V)	Dropout Voltage (mV)				
	Condition	V <sub>DIF</sub> (ECO=H)		V <sub>DIF</sub> (ECO=L)	
		Typ.	Max.	Typ.	Max.
1.5 ≤ V <sub>OUT</sub> < 1.6	I <sub>OUT</sub> = 150mA	400	680	420	680
1.6 ≤ V <sub>OUT</sub> < 1.7		380	550	390	550
1.7 ≤ V <sub>OUT</sub> < 1.8		350	520	370	520
1.8 ≤ V <sub>OUT</sub> < 2.0		340	490	350	490
2.0 ≤ V <sub>OUT</sub> < 2.8		290	425	300	430
2.8 ≤ V <sub>OUT</sub> ≤ 4.0		250	350	250	350

## TYPICAL APPLICATION

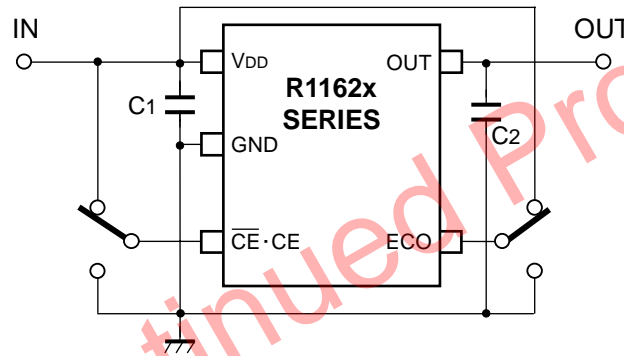

(External Components)

C2 Ceramic 0.47μF Ex. Murata GRM40B474K  
Kyocera CM105B474K

C1 Ceramic 1.0μF

## TYPICAL CHARACTERISTICS Unless otherwise provided, capacitors are ceramic type.

### 1) Output Voltage vs. Output Current

R1162x15x (ECO=H)

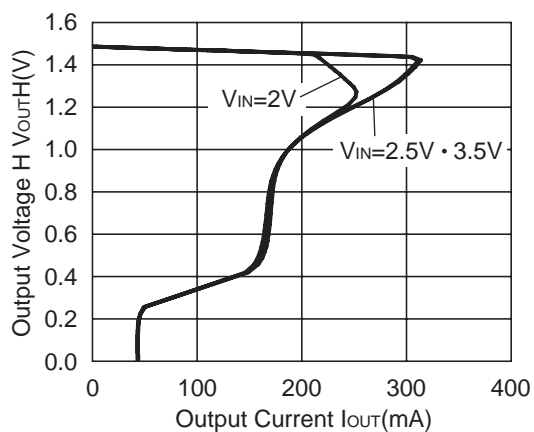

R1162x15x (ECO=L)

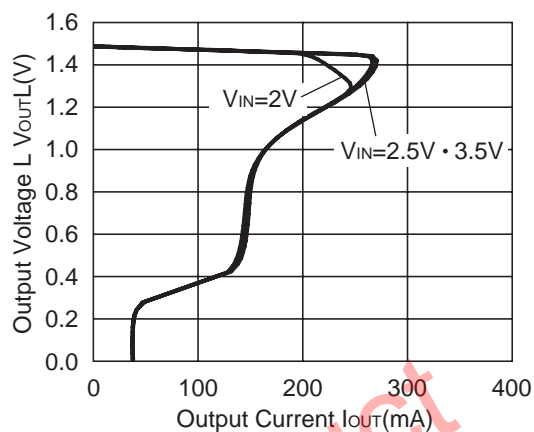

R1162x28x (ECO=H)

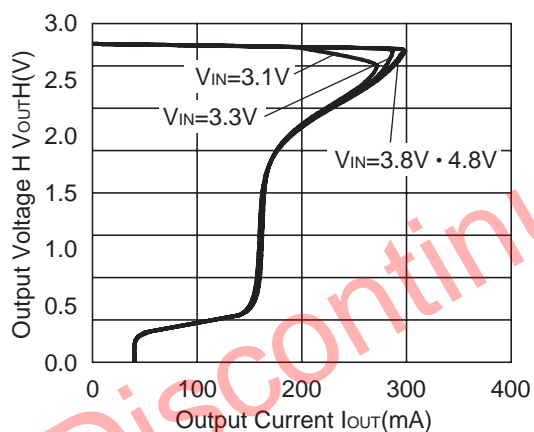

R1162x28x (ECO=L)

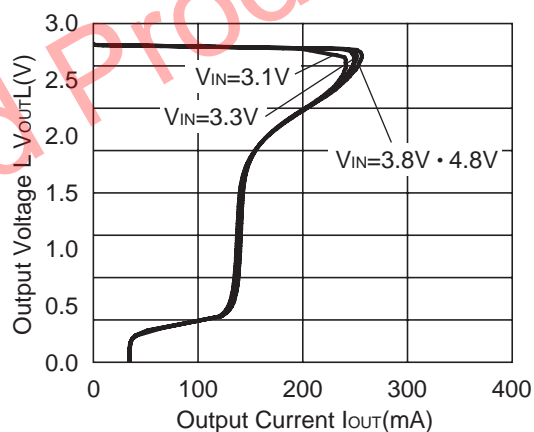

R1162x40x (ECO=H)

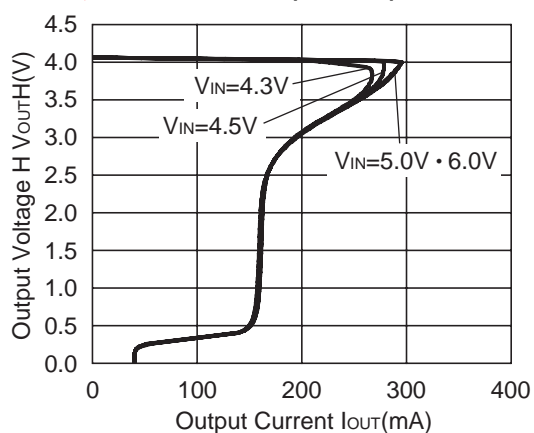

R1162x40x (ECO=L)

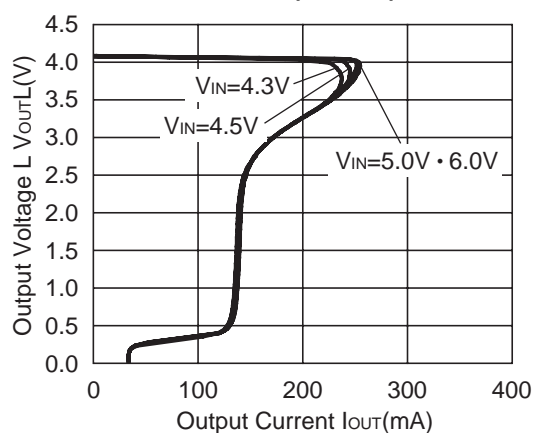

2) Output Voltage vs. Input Voltage

R1162x15x (ECO=H)

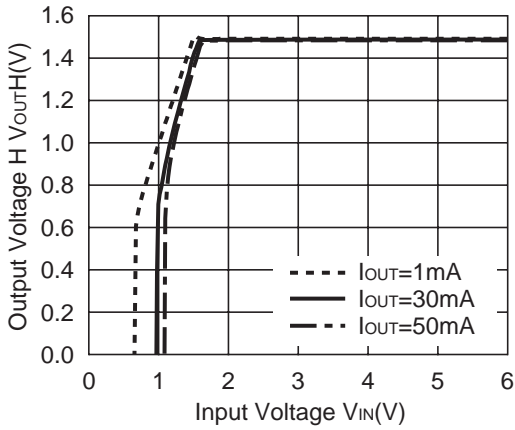

R1162x15x (ECO=L)

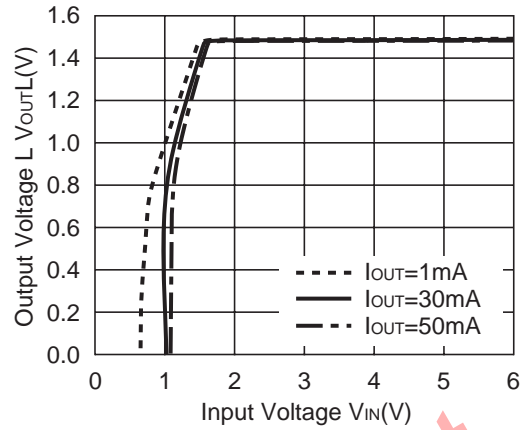

R1162x28x (ECO=H)

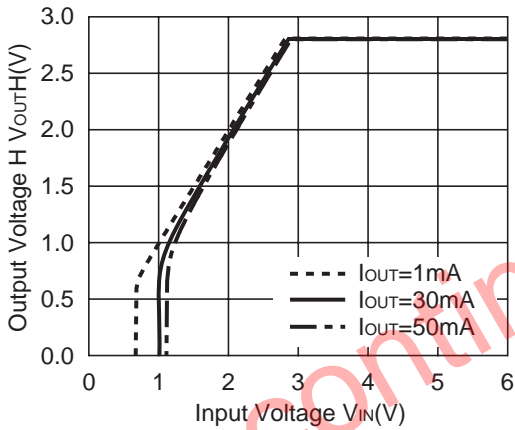

R1162x28x (ECO=L)

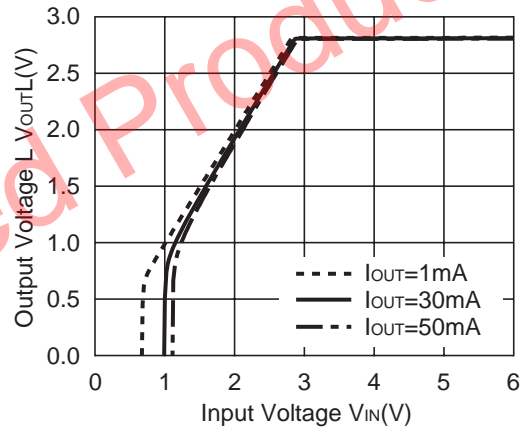

R1162x40x (ECO=H)

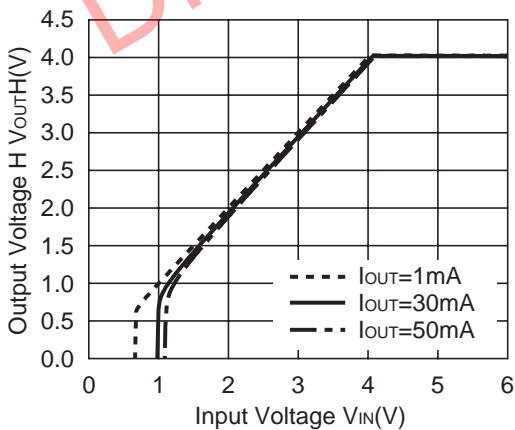

R1162x40x (ECO=L)

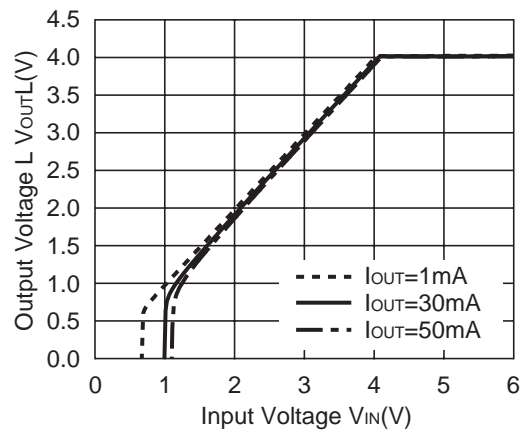



## 3) Supply Current vs. Input Voltage

R1162x15x (ECO=H)

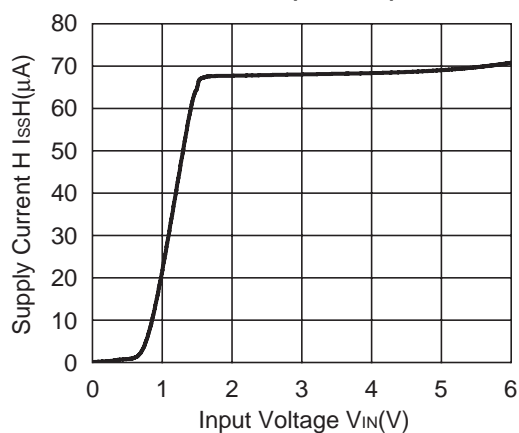

R1162x15x (ECO=L)

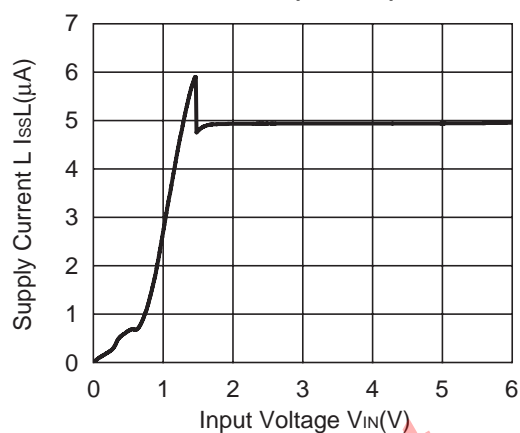

R1162x28x (ECO=H)

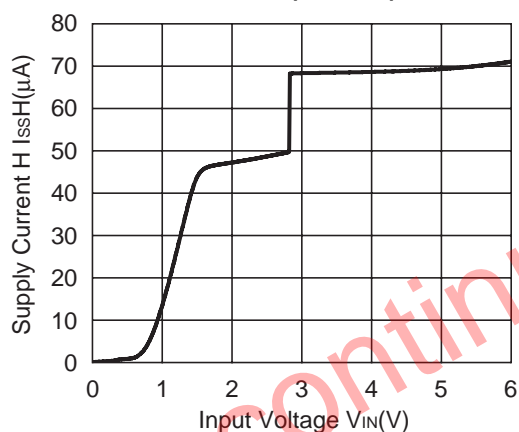

R1162x28x (ECO=L)

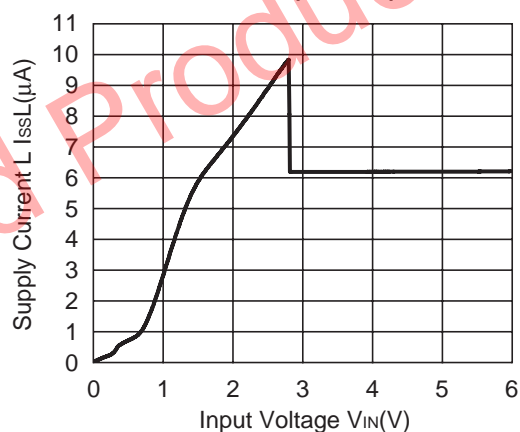

R1162x40x (ECO=H)

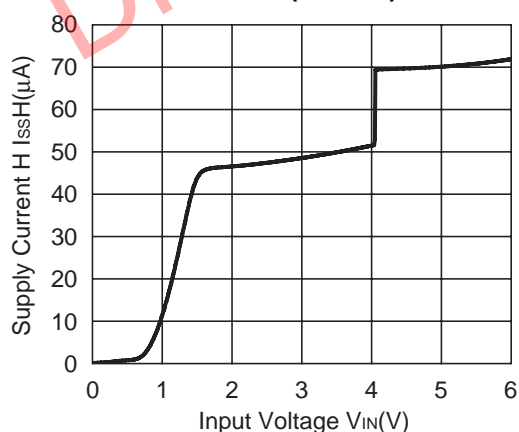

R1162x40x (ECO=L)

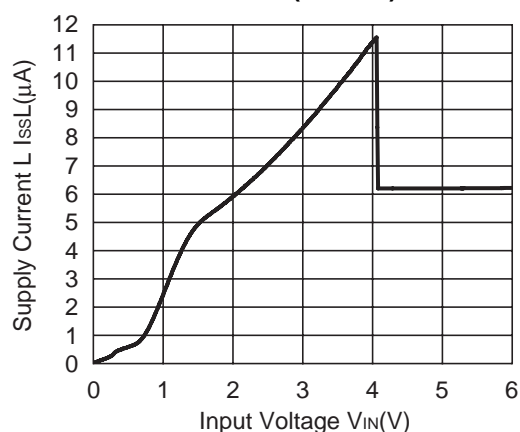

4) Output Voltage vs. Temperature

R1162x15x (ECO=H)

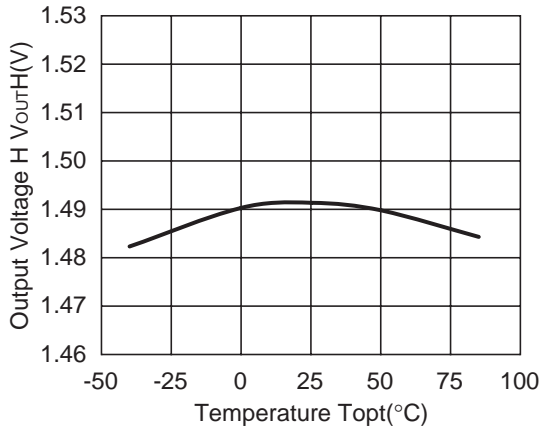

R1162x15x (ECO=L)

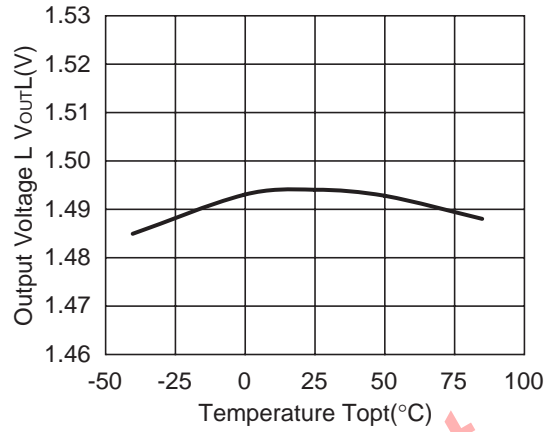

R1162x28x (ECO=H)

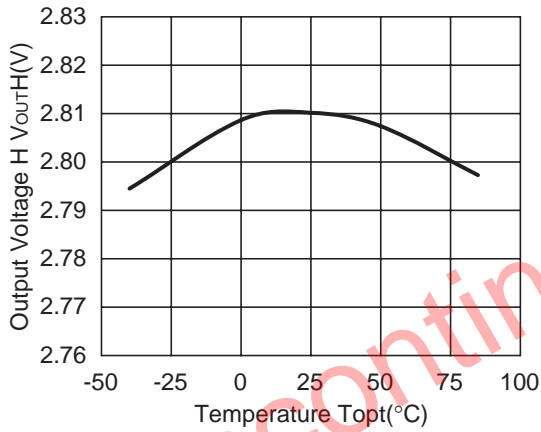

R1162x28x (ECO=L)

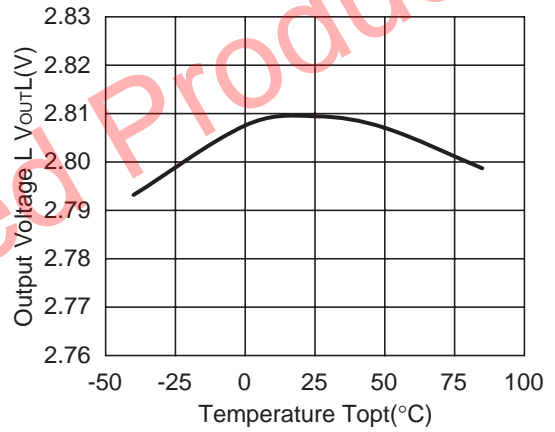

R1162x40x (ECO=H)

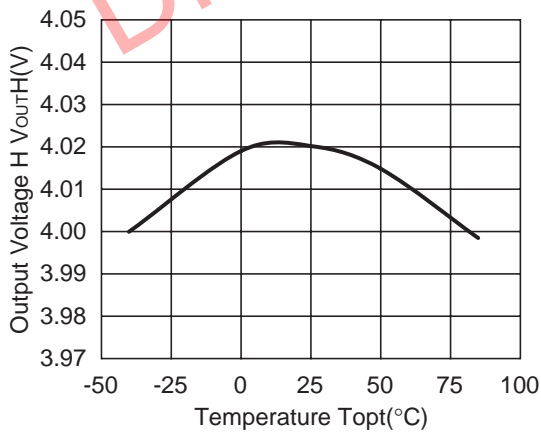

R1162x40x (ECO=L)

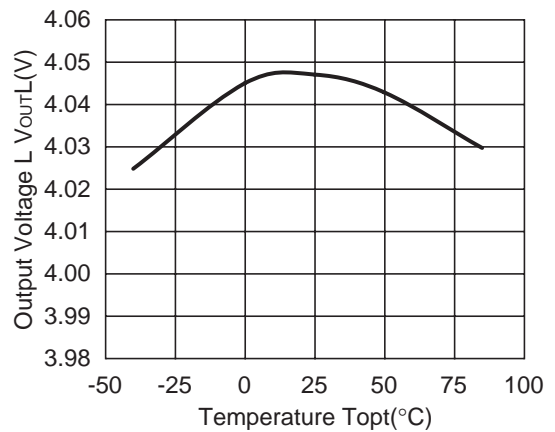

## 5) Supply Current vs. Temperature

R1162x15x (ECO=H)

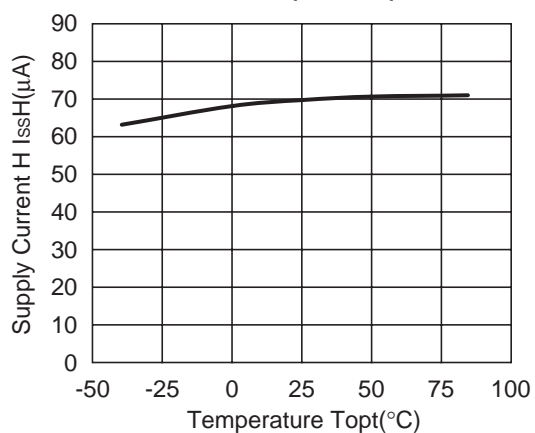

R1162x15x (ECO=L)

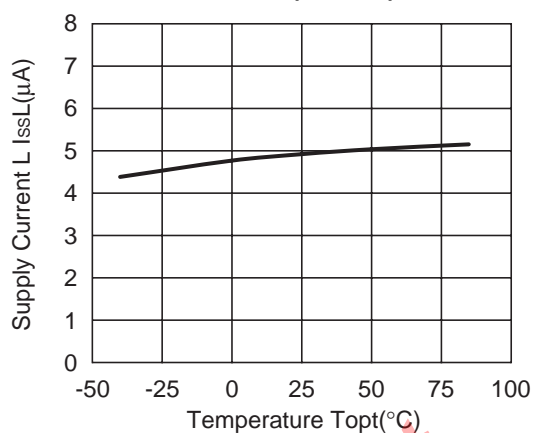

R1162x28x (ECO=H)

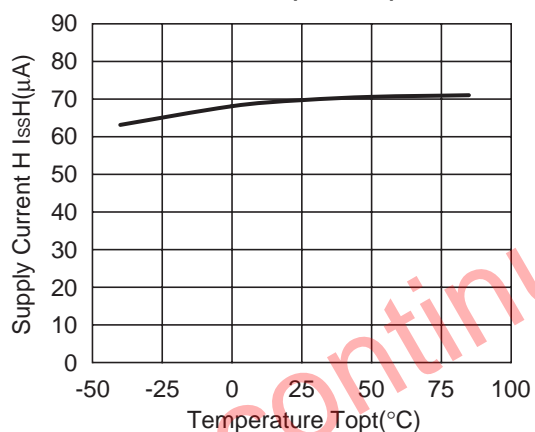

R1162x28x (ECO=L)

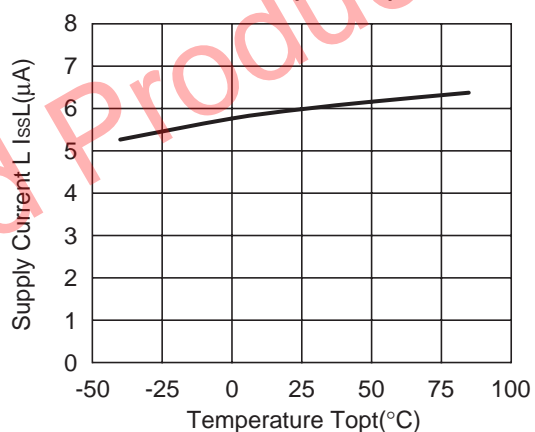

R1162x40x (ECO=H)

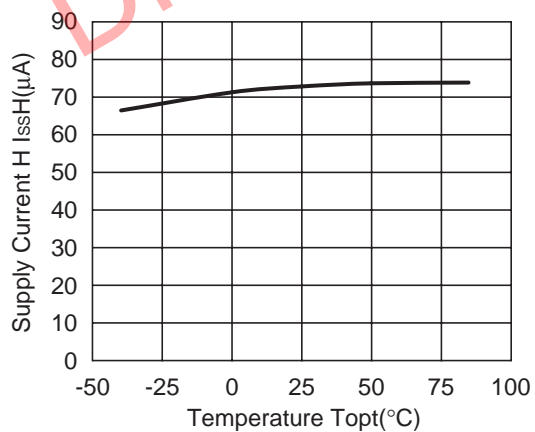

R1162x40x (ECO=L)

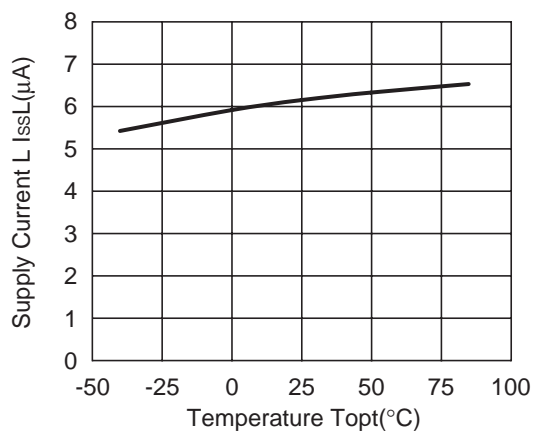

6) Dropout Voltage vs. Output Current

R1162x15x (ECO=H)

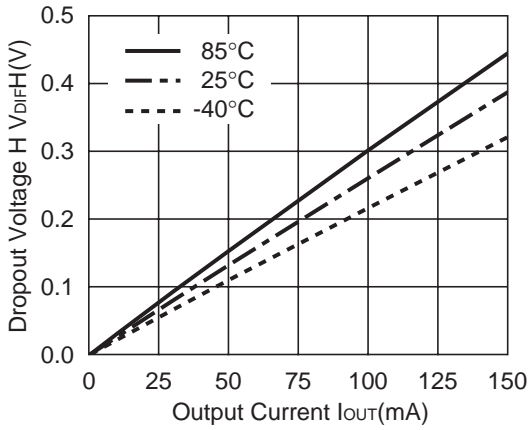

R1162x15x (ECO=L)

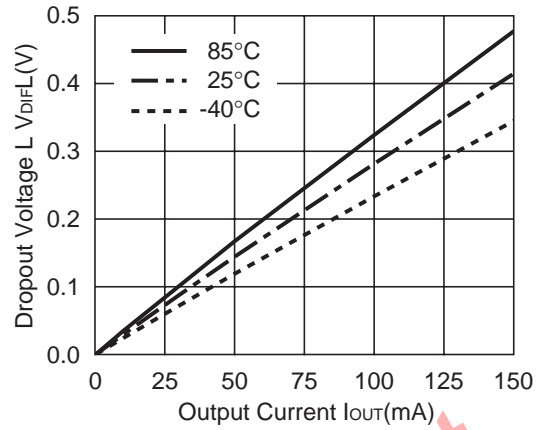

R1162x16x (ECO=H)

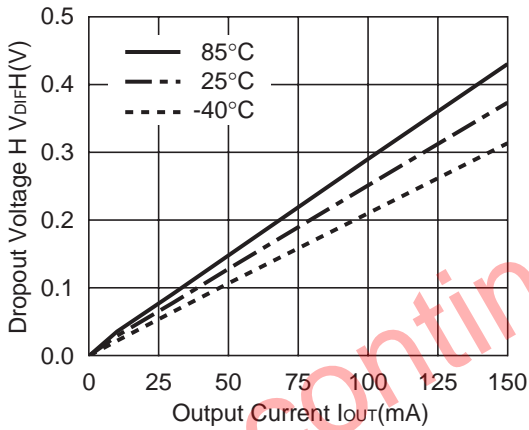

R1162x16x (ECO=L)

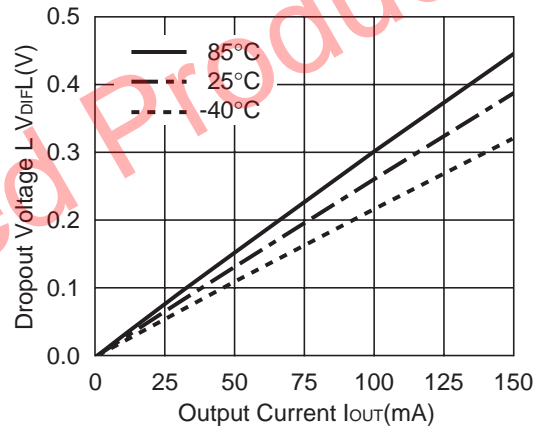

R1162x17x (ECO=H)

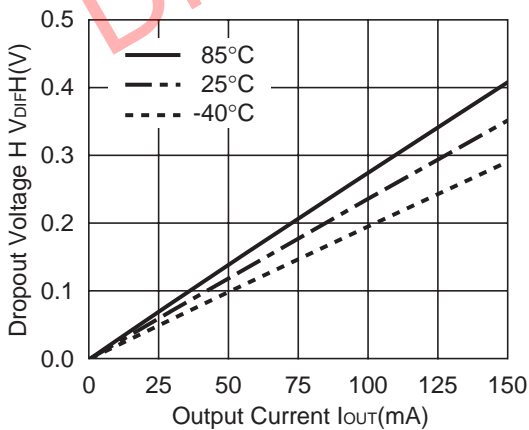

R1162x17x (ECO=L)

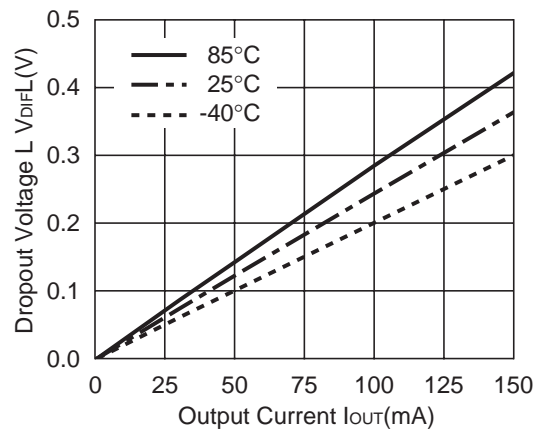

R1162x18x (ECO=H)

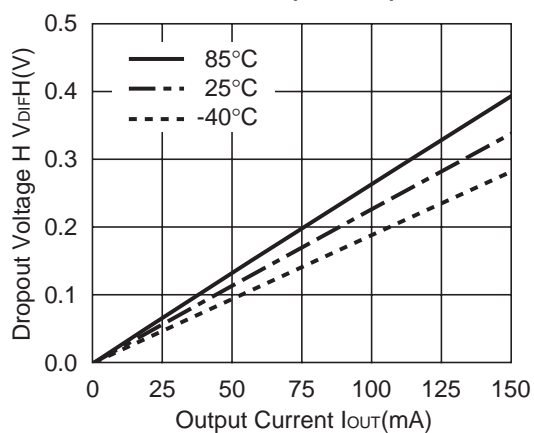

R1162x18x (ECO=L)

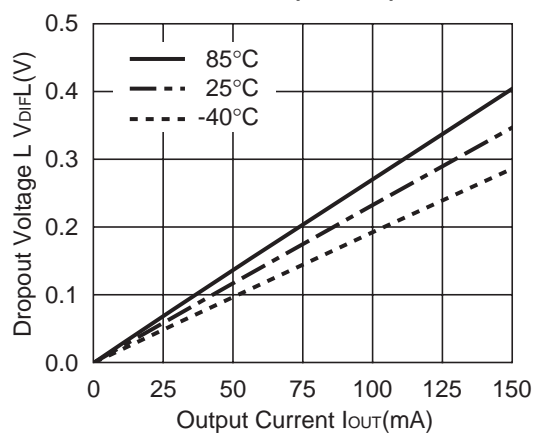

R1162x21x (ECO=H)

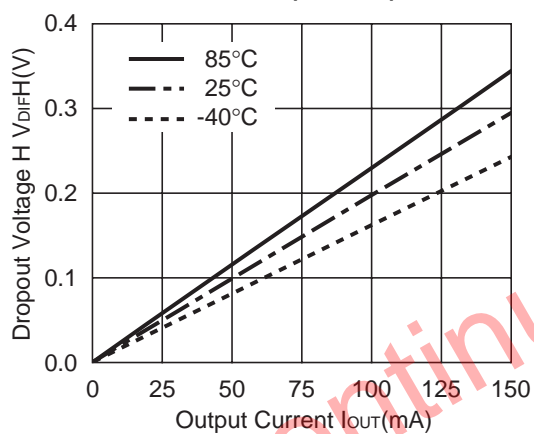

R1162x21x (ECO=L)

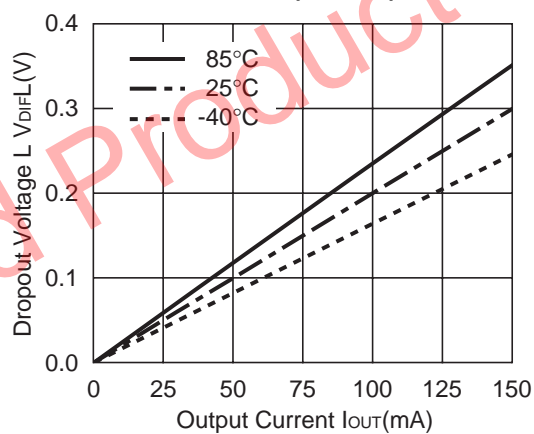

R1162x28x (ECO=H)

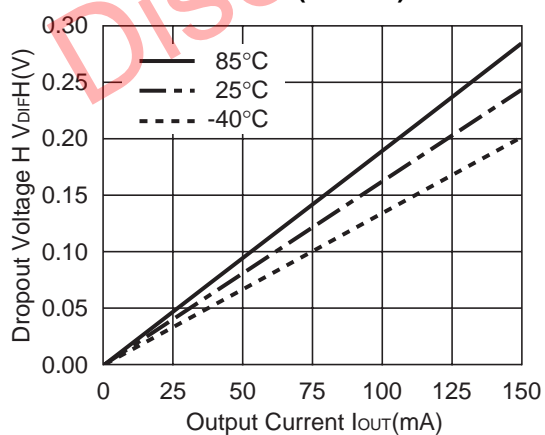

R1162x28x (ECO=L)

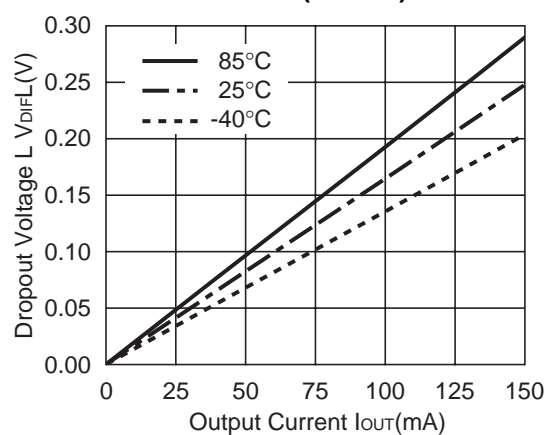

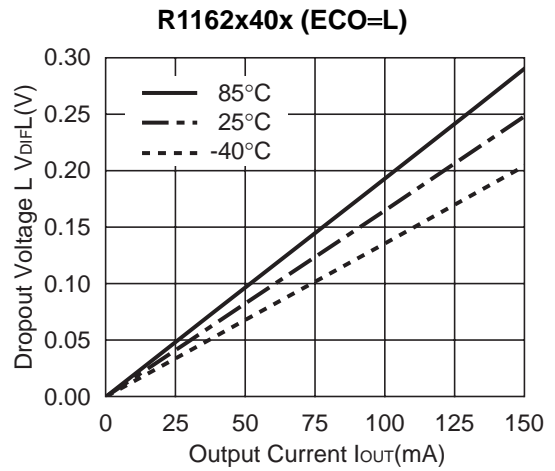
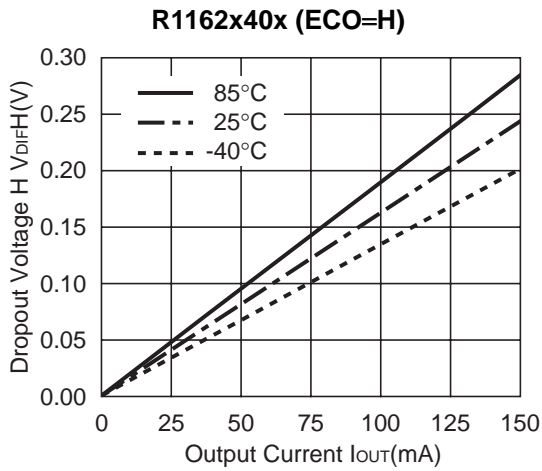

**7) Dropout Voltage vs. Set Output Voltage**

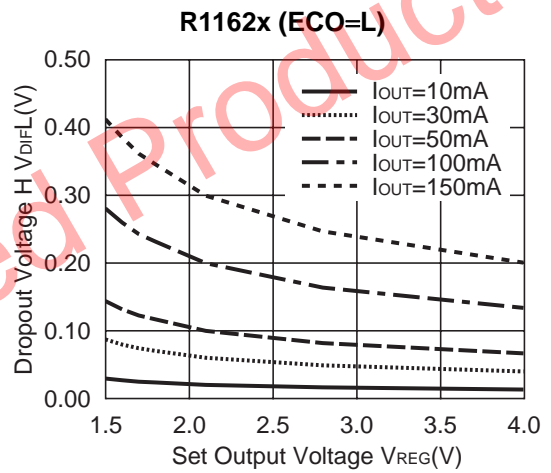
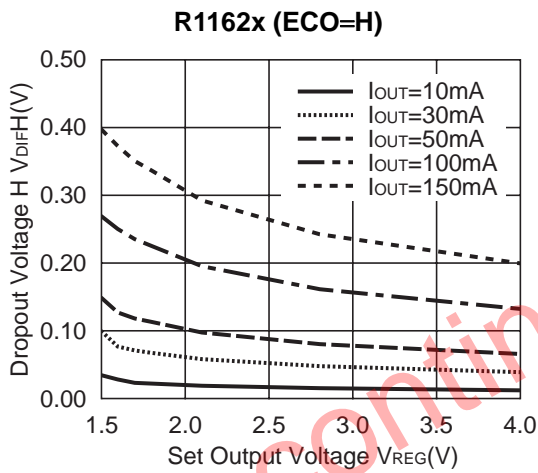

**8) Ripple Rejection vs. Input Bias Voltage**

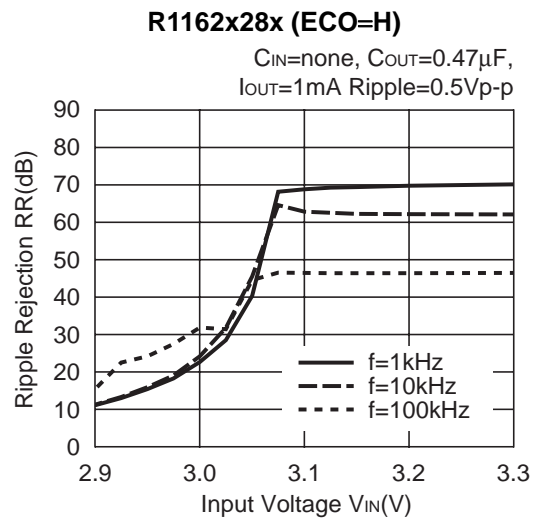
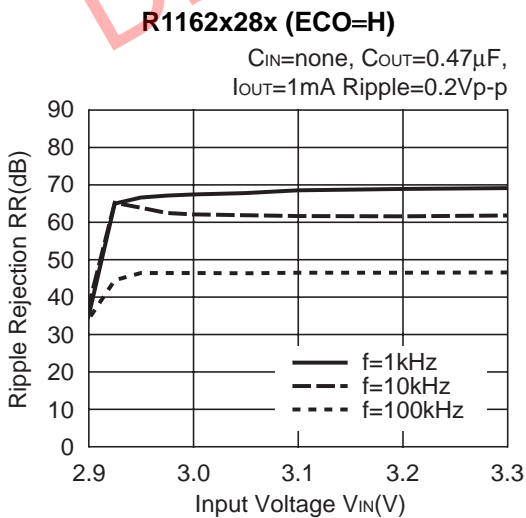

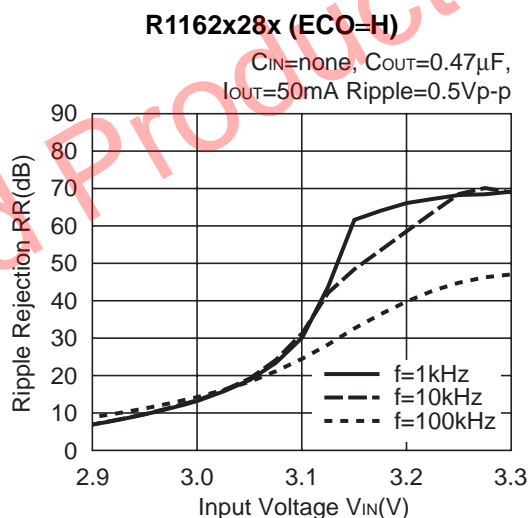
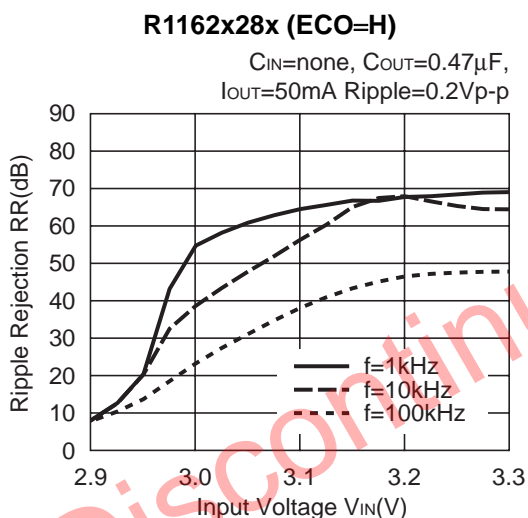
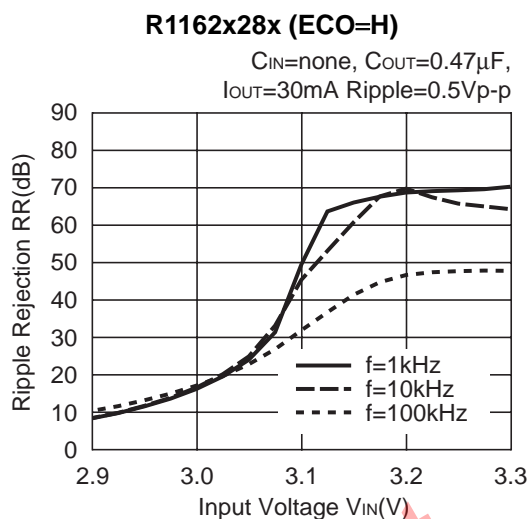
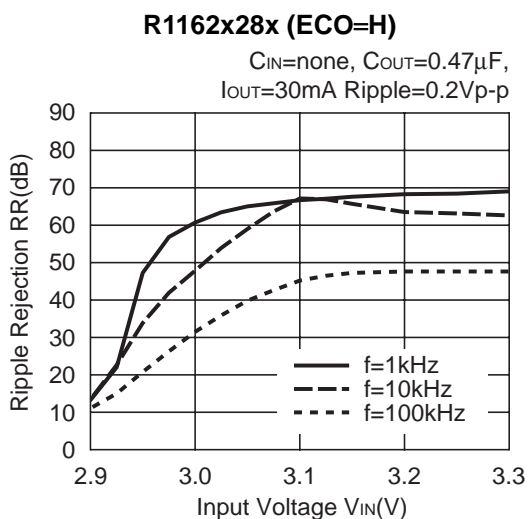

**9) Ripple Rejection vs. Frequency**

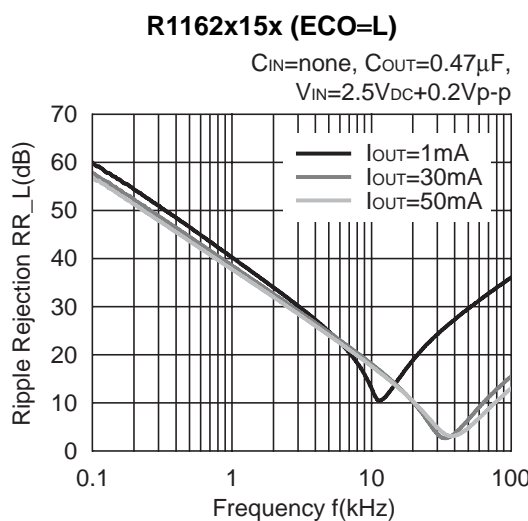
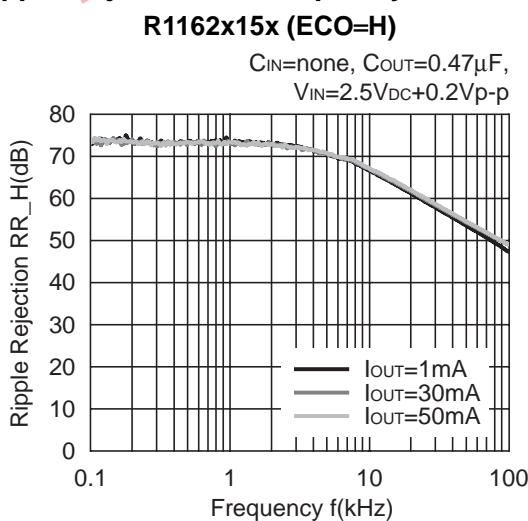

**R1162x28x (ECO=H)**

$C_{IN}$ =none,  $C_{OUT}$ =0.47 $\mu$ F,  
 $V_{IN}$ =3.8V<sub>DC</sub>+0.2V<sub>p-p</sub>

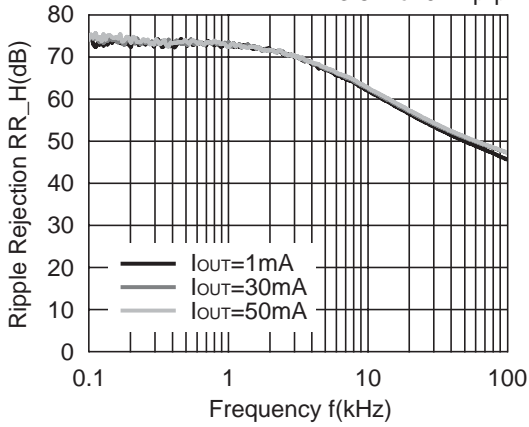

**R1162x28x (ECO=L)**

$C_{IN}$ =none,  $C_{OUT}$ =0.47 $\mu$ F,  
 $V_{IN}$ =3.8V<sub>DC</sub>+0.2V<sub>p-p</sub>

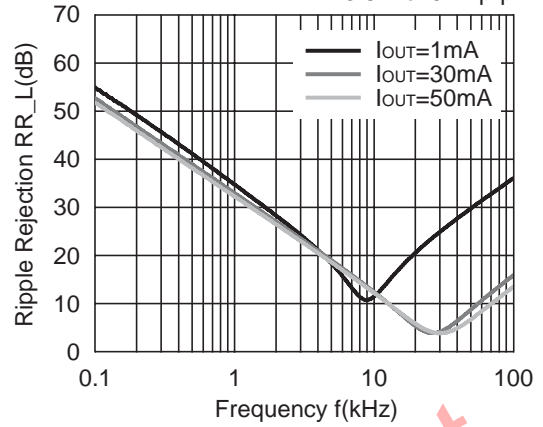

**R1162x40x (ECO=H)**

$C_{IN}$ =none,  $C_{OUT}$ =0.47 $\mu$ F,  
 $V_{IN}$ =5.0V<sub>DC</sub>+0.2V<sub>p-p</sub>

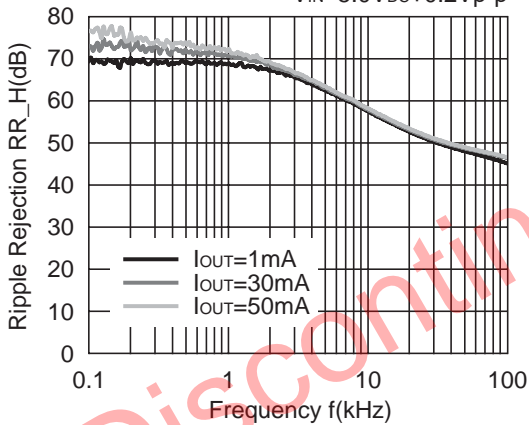

**R1162x40x (ECO=L)**

$C_{IN}$ =none,  $C_{OUT}$ =0.47 $\mu$ F,  
 $V_{IN}$ =5.0V<sub>DC</sub>+0.2V<sub>p-p</sub>

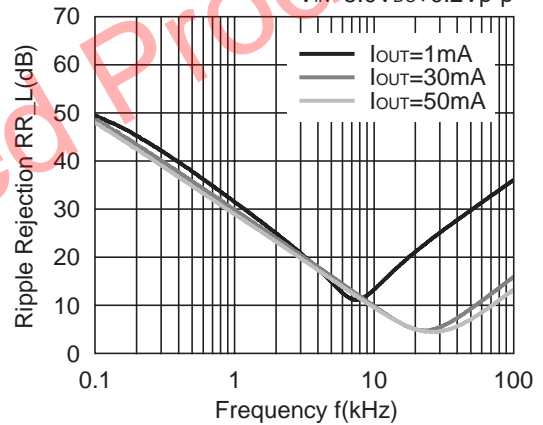

**10) Input Transient Response**

**R1162x15x (ECO=H)**

$C_{IN}$ =none,  $C_{OUT}$ =0.47 $\mu$ F,  $I_{OUT}$ =30mA

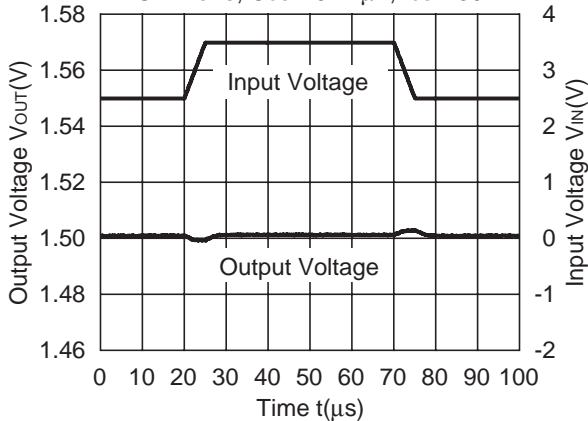

**R1162x15x (ECO=L)**

$C_{IN}$ =none,  $C_{OUT}$ =0.47 $\mu$ F,  $I_{OUT}$ =10mA

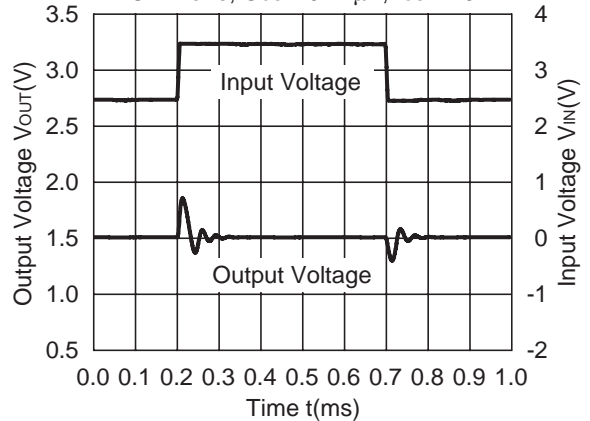



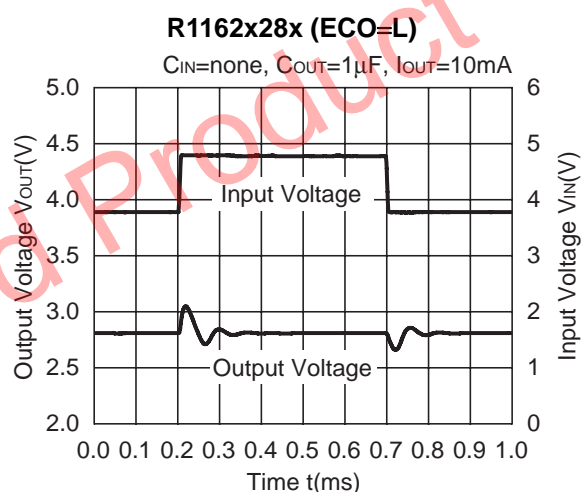
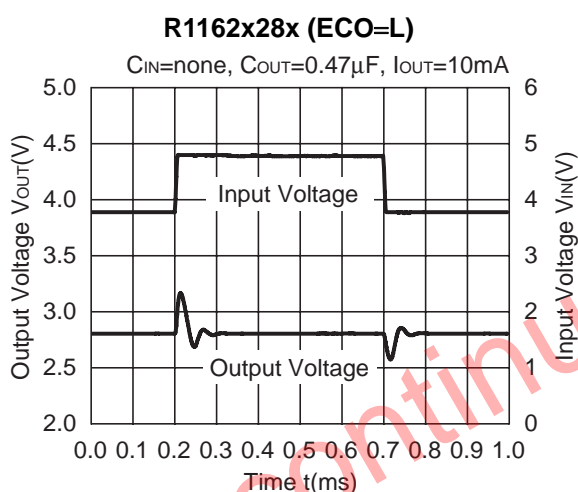
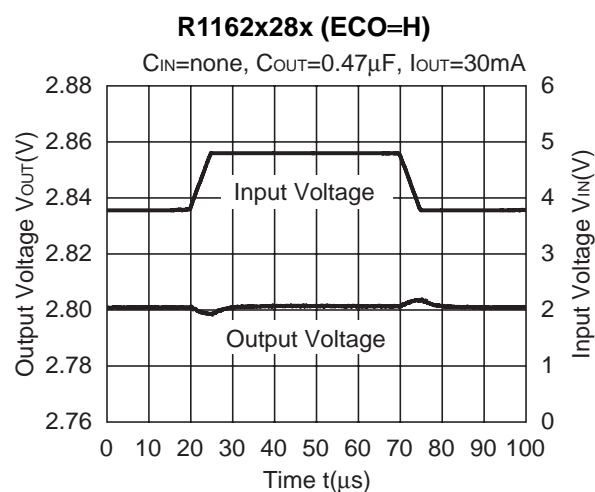
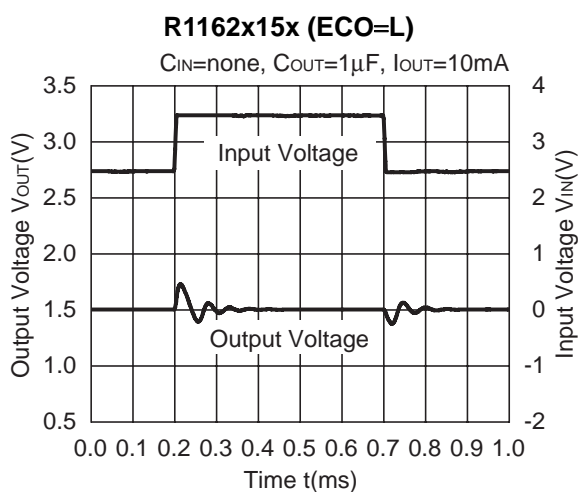

## 11) Load Transient Response

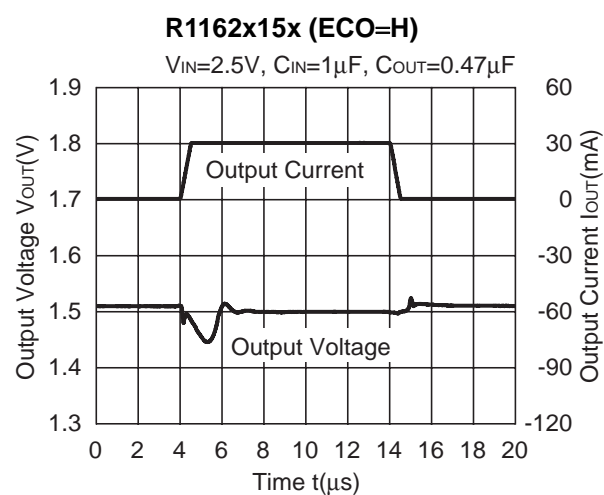
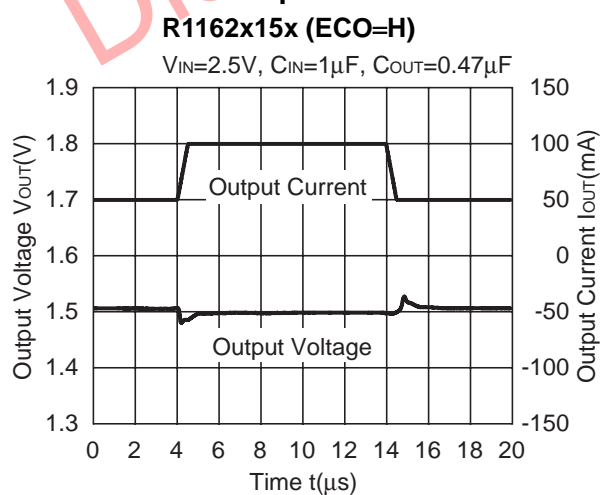

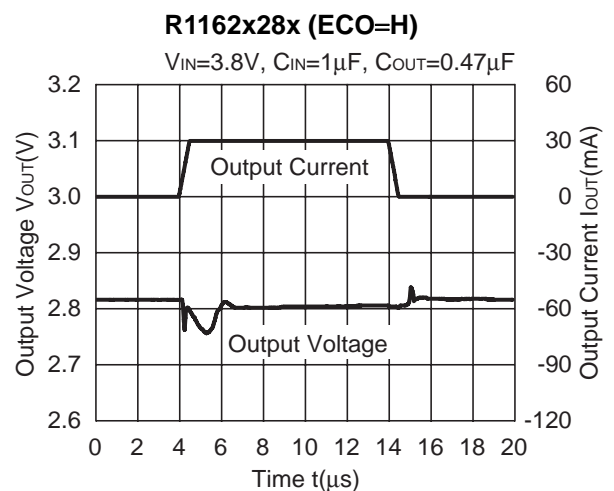
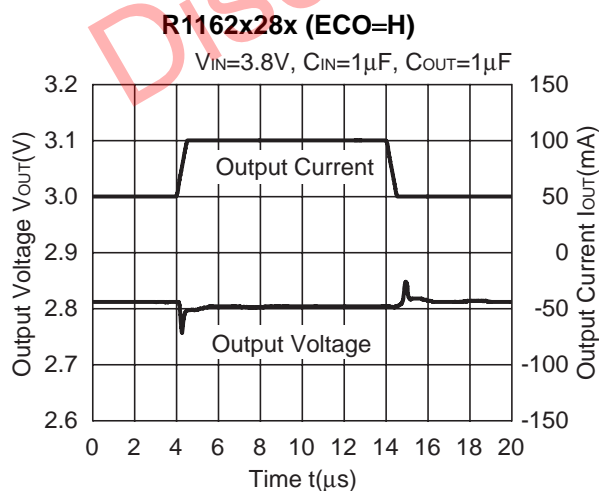
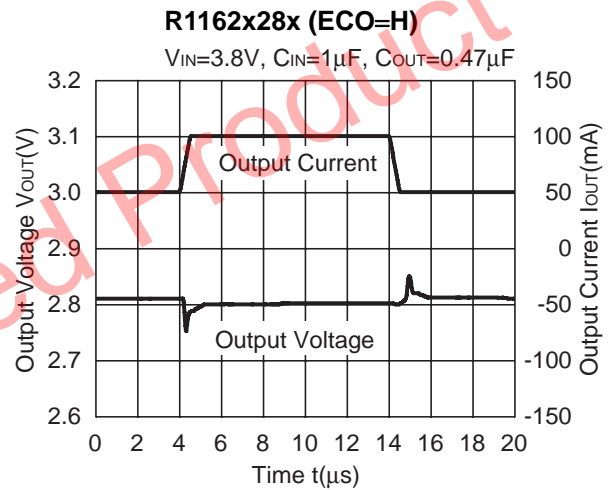
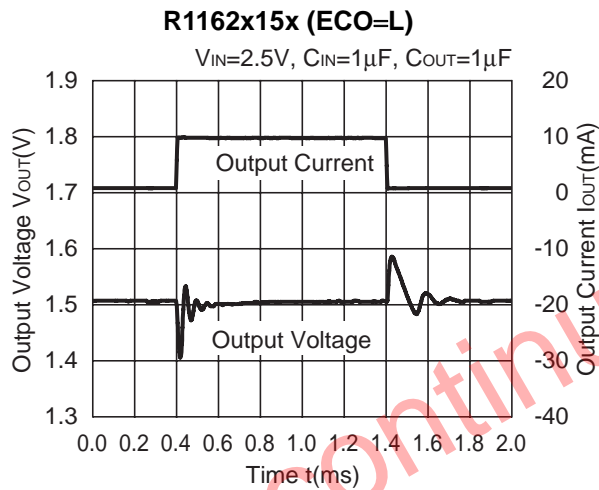
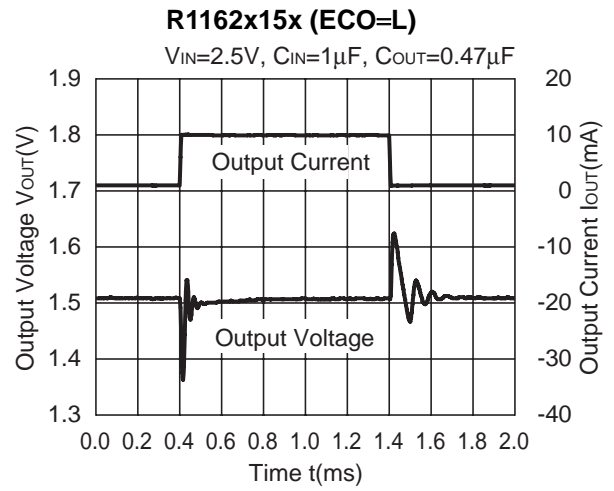
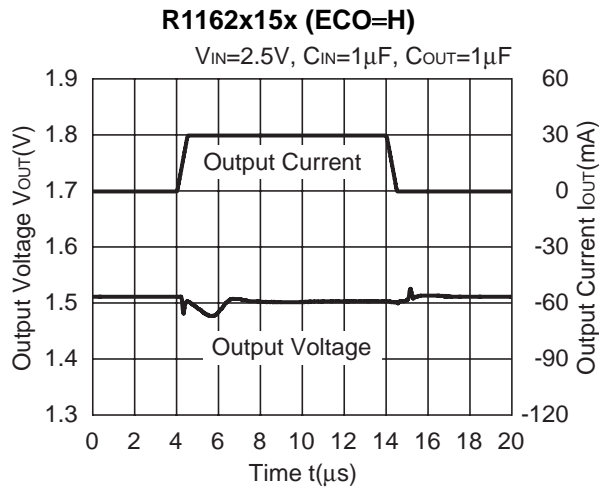

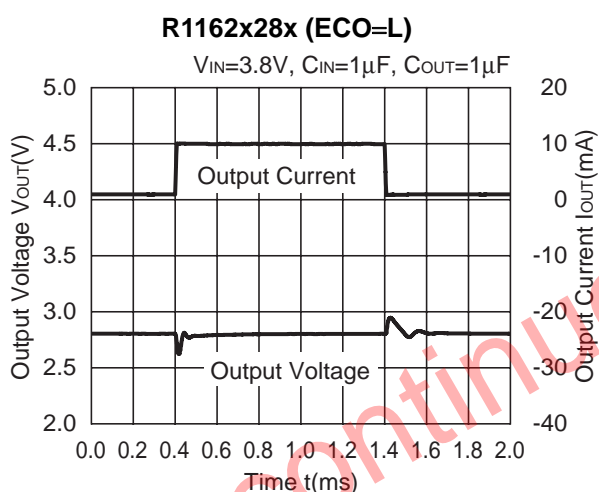
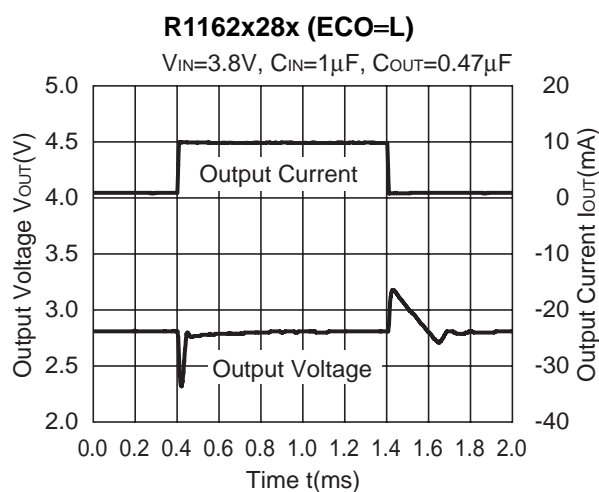
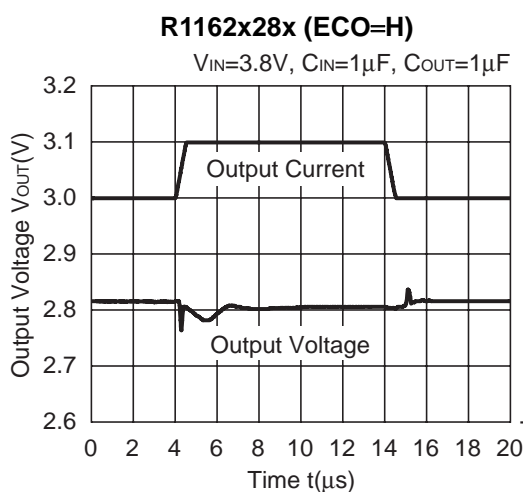

## 12) Turn on speed with CE pin

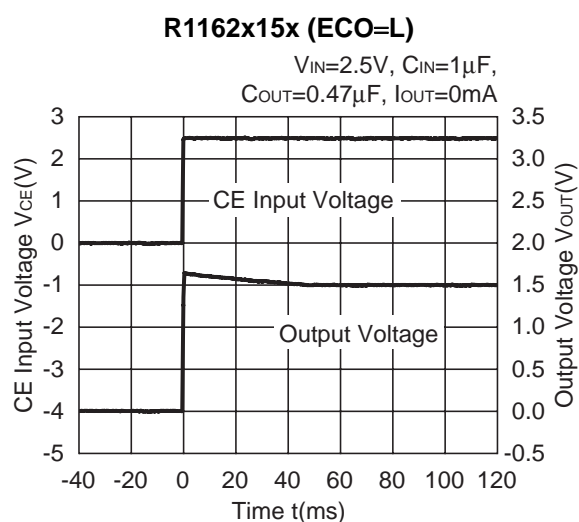
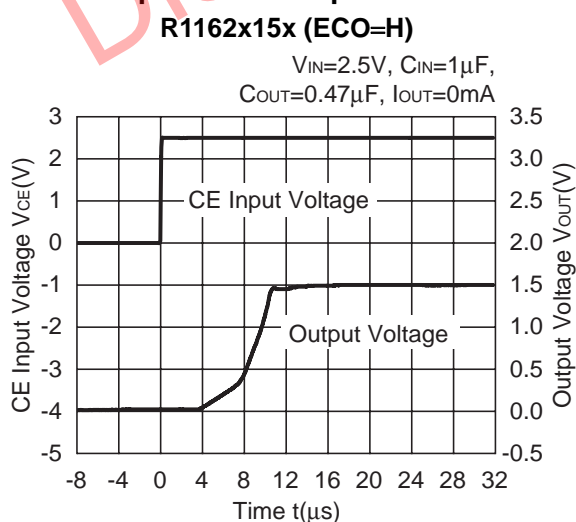

**R1162x15x (ECO=H)**

$V_{IN}=2.5V$ ,  $C_{IN}=1\mu F$ ,  
 $C_{OUT}=0.47\mu F$ ,  $I_{OUT}=30mA$

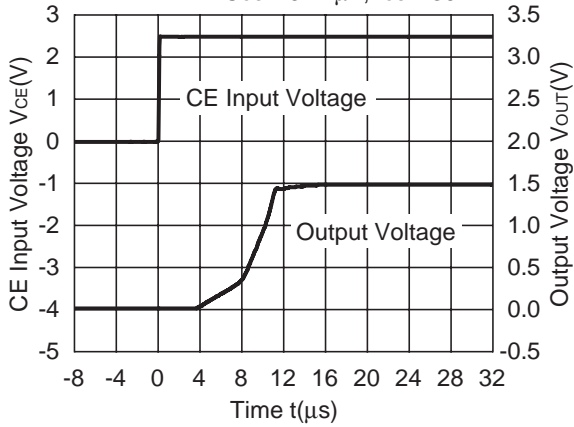

**R1162x15x (ECO=L)**

$V_{IN}=2.5V$ ,  $C_{IN}=1\mu F$ ,  
 $C_{OUT}=0.47\mu F$ ,  $I_{OUT}=30mA$

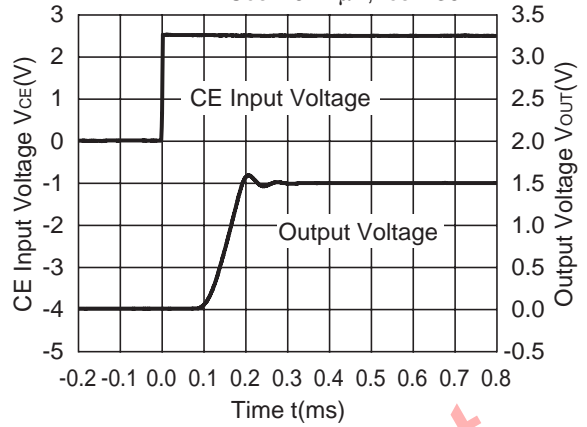

**R1162x15x (ECO=H)**

$V_{IN}=2.5V$ ,  $C_{IN}=1\mu F$ ,  
 $C_{OUT}=0.47\mu F$ ,  $I_{OUT}=150mA$

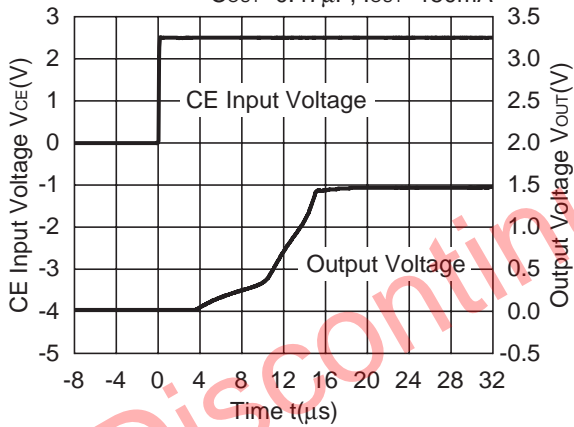

**R1162x15x (ECO=L)**

$V_{IN}=2.5V$ ,  $C_{IN}=1\mu F$ ,  
 $C_{OUT}=0.47\mu F$ ,  $I_{OUT}=150mA$

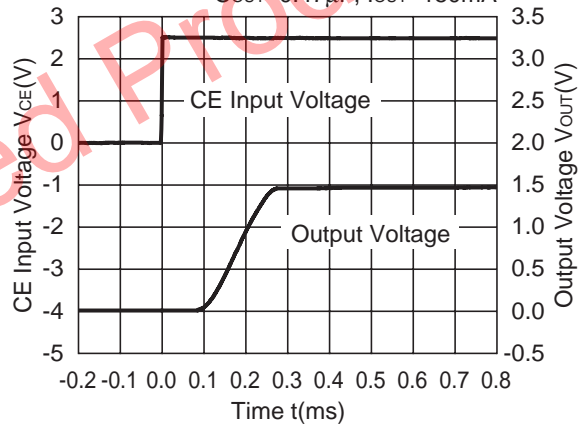

**R1162x28x (ECO=H)**

$V_{IN}=3.8V$ ,  $C_{IN}=1\mu F$ ,  
 $C_{OUT}=0.47\mu F$ ,  $I_{OUT}=0mA$

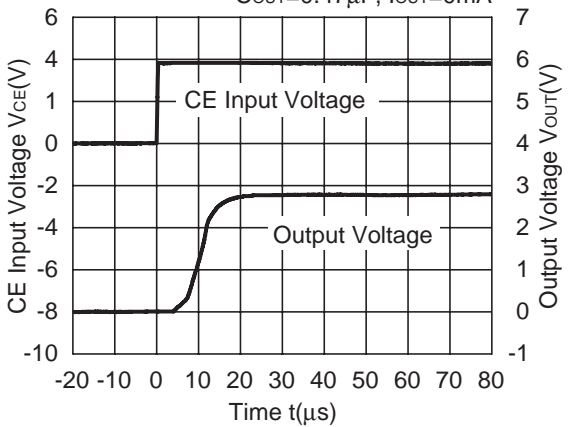

**R1162x28x (ECO=L)**

$V_{IN}=3.8V$ ,  $C_{IN}=1\mu F$ ,  
 $C_{OUT}=0.47\mu F$ ,  $I_{OUT}=0mA$

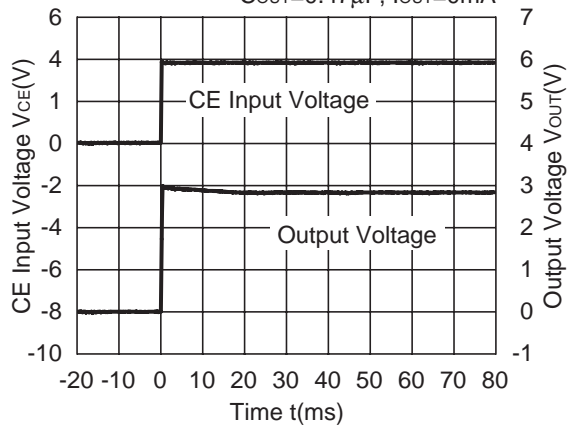

**R1162x28x (ECO=H)**

$V_{IN}=3.8V$ ,  $C_{IN}=1\mu F$ ,  
 $C_{OUT}=0.47\mu F$ ,  $I_{OUT}=30mA$

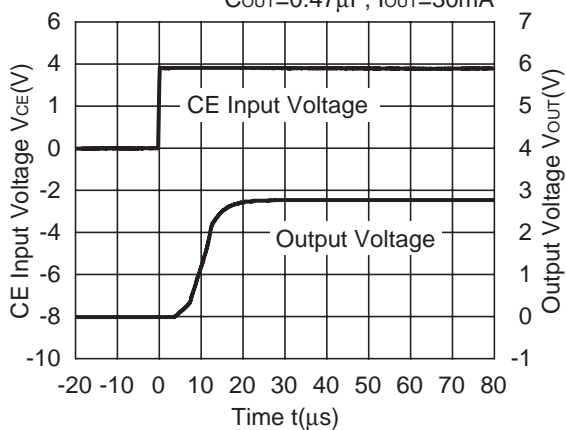
**R1162x28x (ECO=L)**

$V_{IN}=3.8V$ ,  $C_{IN}=1\mu F$ ,  
 $C_{OUT}=0.47\mu F$ ,  $I_{OUT}=30mA$

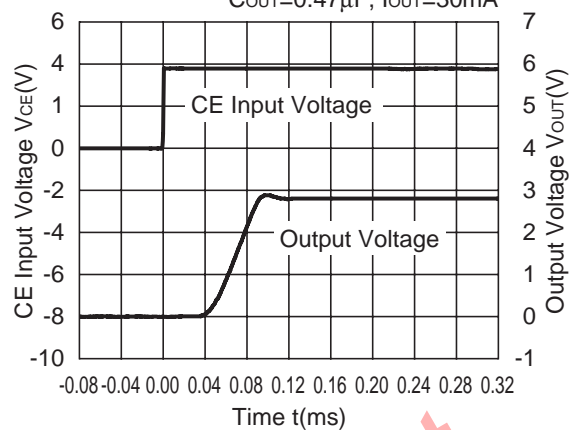
**R1162x28x (ECO=H)**

$V_{IN}=3.8V$ ,  $C_{IN}=1\mu F$ ,  
 $C_{OUT}=0.47\mu F$ ,  $I_{OUT}=150mA$

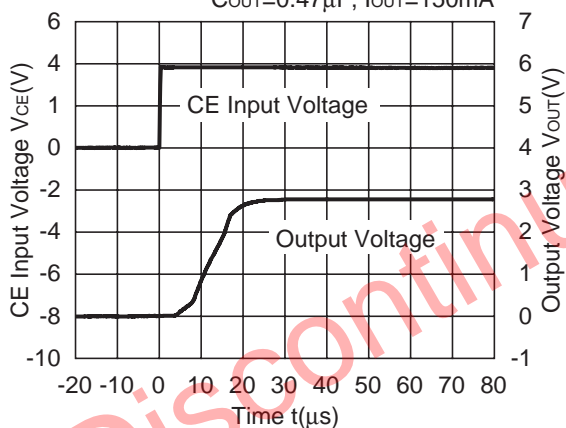
**R1162x28x (ECO=L)**

$V_{IN}=3.8V$ ,  $C_{IN}=1\mu F$ ,  
 $C_{OUT}=0.47\mu F$ ,  $I_{OUT}=150mA$

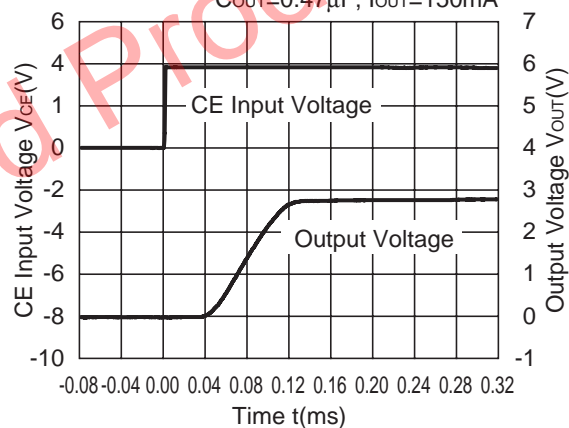
**R1162x40x (ECO=H)**

$V_{IN}=5.0V$ ,  $C_{IN}=1\mu F$ ,  
 $C_{OUT}=0.47\mu F$ ,  $I_{OUT}=0mA$

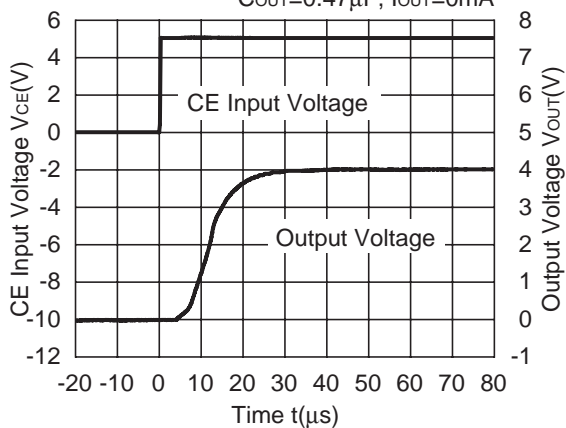
**R1162x40x (ECO=L)**

$V_{IN}=5.0V$ ,  $C_{IN}=1\mu F$ ,  
 $C_{OUT}=0.47\mu F$ ,  $I_{OUT}=0mA$

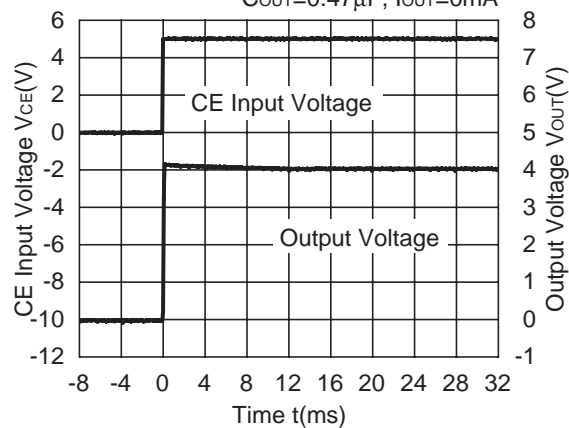

**R1162x40x (ECO=H)**

$V_{IN}=5.0V$ ,  $C_{IN}=1\mu F$ ,  
 $C_{OUT}=0.47\mu F$ ,  $I_{OUT}=30mA$

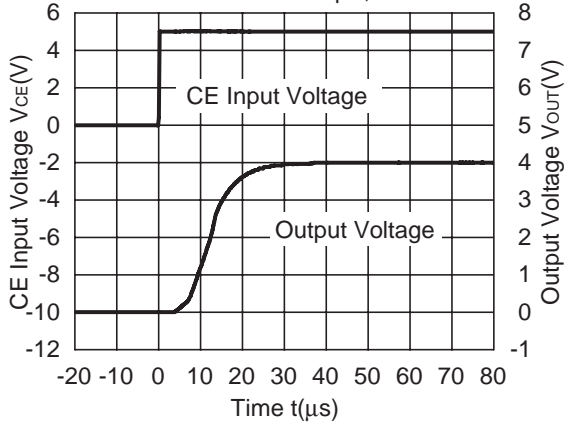

**R1162x40x (ECO=L)**

$V_{IN}=5.0V$ ,  $C_{IN}=1\mu F$ ,  
 $C_{OUT}=0.47\mu F$ ,  $I_{OUT}=30mA$

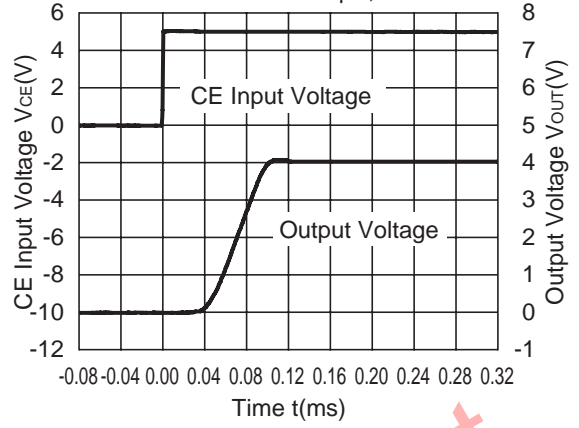

**R1162x40x (ECO=H)**

$V_{IN}=5.0V$ ,  $C_{IN}=1\mu F$ ,  
 $C_{OUT}=0.47\mu F$ ,  $I_{OUT}=150mA$

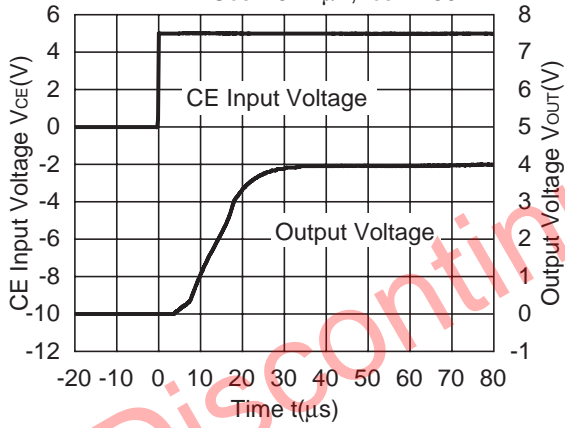

**R1162x40x (ECO=L)**

$V_{IN}=5.0V$ ,  $C_{IN}=1\mu F$ ,  
 $C_{OUT}=0.47\mu F$ ,  $I_{OUT}=150mA$

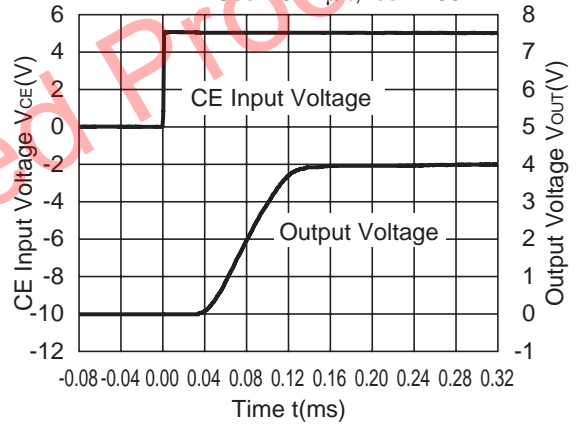

Discontinued Product

13) Turn off speed with CE pin

R1162x15xD

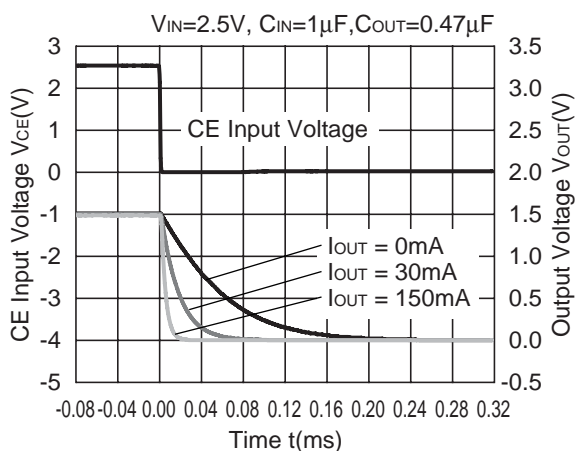

R1162x28xD

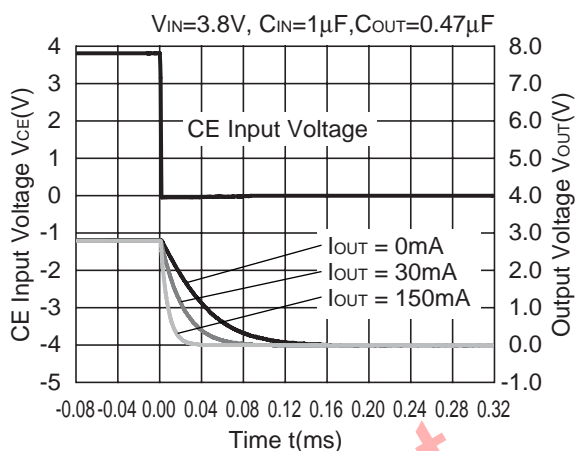

R1162x40xD

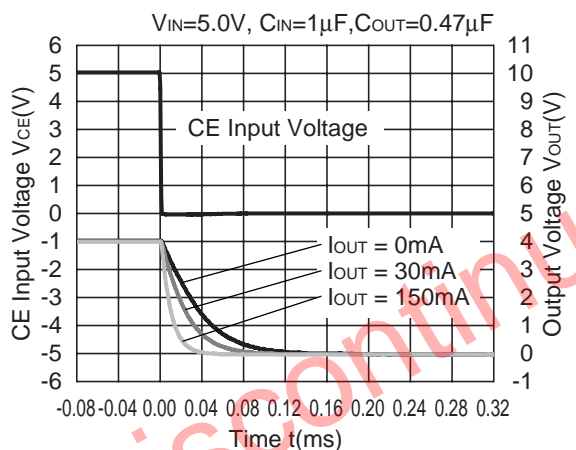

Discontinued Product

14) Output Voltage at Mode alternative point

**R1162x15x**

$V_{IN}=2.5V$ ,  $C_{IN}=\text{Ceramic } 1.0\mu F$ ,  
 $C_{OUT}=\text{Ceramic } 0.47\mu F$

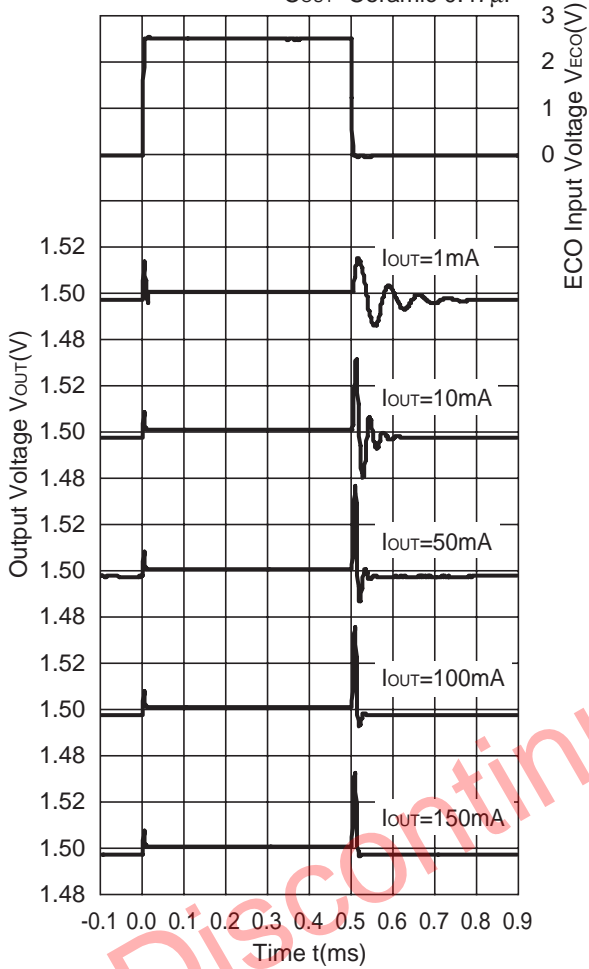

**R1162x28x**

$V_{IN}=3.8V$ ,  $C_{IN}=\text{Ceramic } 1.0\mu F$ ,  
 $C_{OUT}=\text{Ceramic } 0.47\mu F$

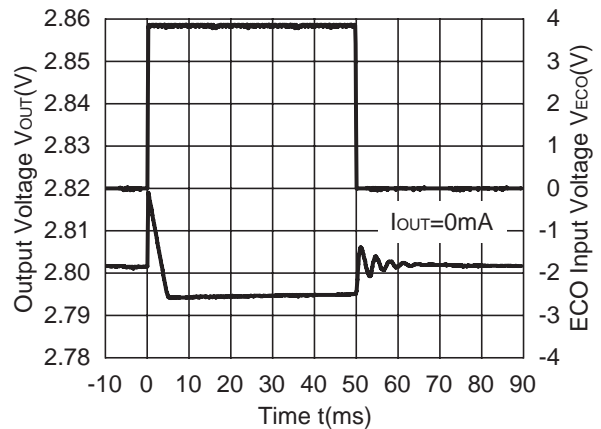
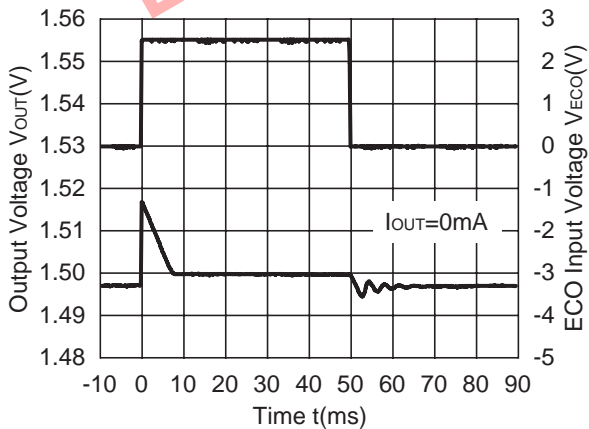
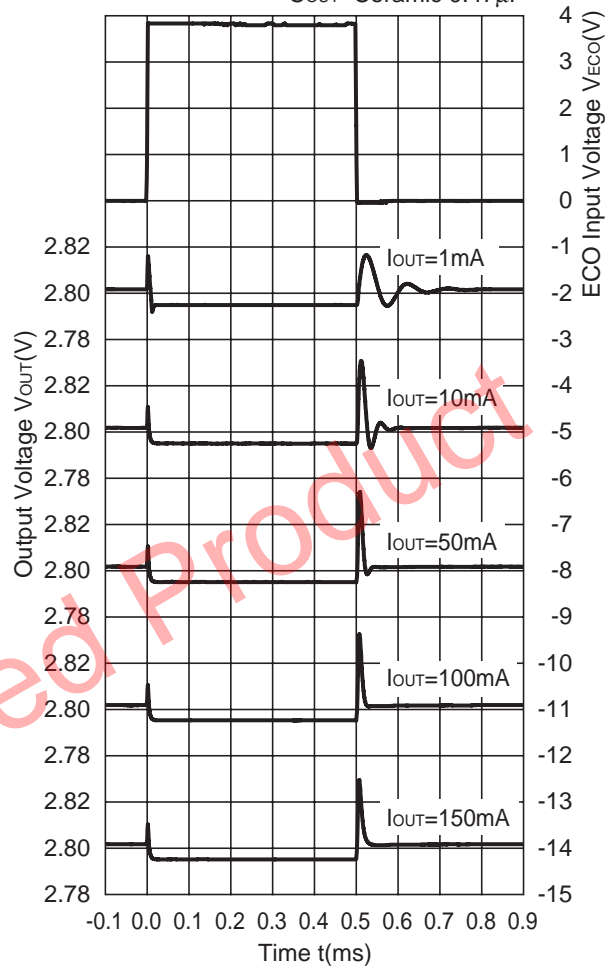



## TECHNICAL NOTES

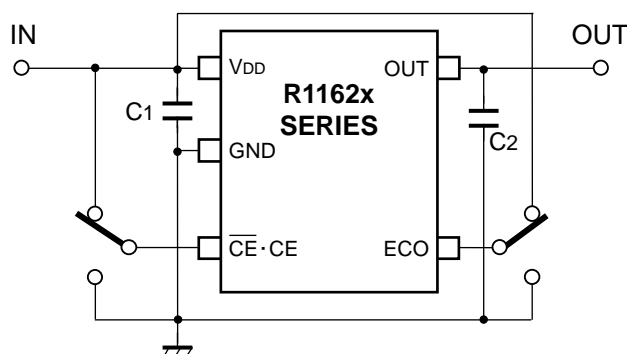

(External Components)

C<sub>2</sub> Ceramic 0.47 $\mu$ F Ex. Murata GRM40B474K  
Kyocera CM105B474K

C<sub>1</sub> Ceramic 1.0 $\mu$ F

When using these ICs, consider the following points:

### 1. Mounting on PCB

Make V<sub>DD</sub> and GND lines sufficient. If their impedance is high, noise pickup or unstable operation may result. Connect a capacitor with as much as 1.0 $\mu$ F capacitor between V<sub>DD</sub> and GND pin as close as possible.

Set external components, especially the output capacitor as close as possible to the ICs and make wiring as short as possible.

### 2. Phase Compensation

In these ICs, phase compensation is made for securing stable operation even if the load current is varied. For this purpose, be sure to use a 0.47 $\mu$ F or more capacitor C<sub>OUT</sub> with good frequency characteristics and ESR (Equivalent Series Resistance).

If you use a tantalum type capacitor and ESR value of the capacitor is large, output might be unstable. Evaluate your circuit with considering frequency characteristics.

Depending on the capacitor size, manufacturer, and part number, the bias characteristics and temperature characteristics are different. Evaluate the circuit with actual using capacitors.

## ESR vs. Output Current

When using these ICs, consider the following points:

In these ICs, phase compensation is made for securing stable operation even if the load current is varied.

For this purpose, be sure to use a capacitor  $C_{OUT}$  with good frequency characteristics and ESR (Equivalent Series Resistance) in the range described as follows:

The relations between  $I_{OUT}$  (Output Current) and ESR of Output Capacitor are shown below.

The conditions when the white noise level is under  $40\mu V$  (Avg.) are marked as the hatched area in the graph.

<Test conditions>

(1) Frequency band: 10Hz to 2MHz

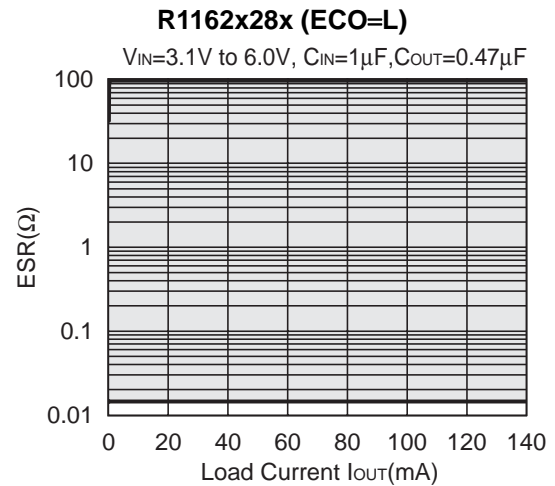
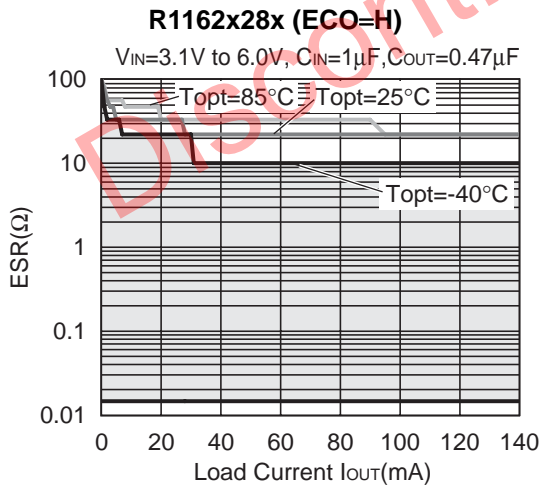
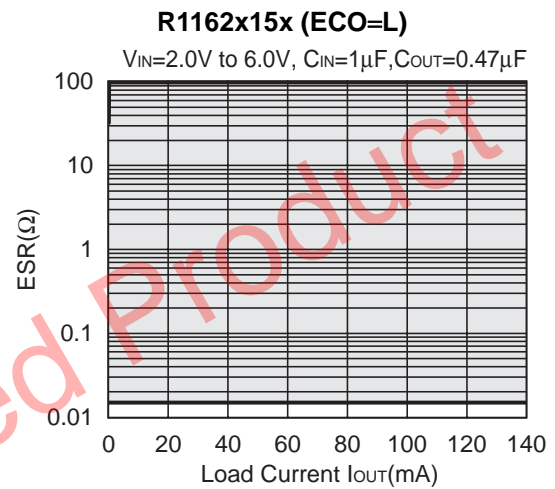
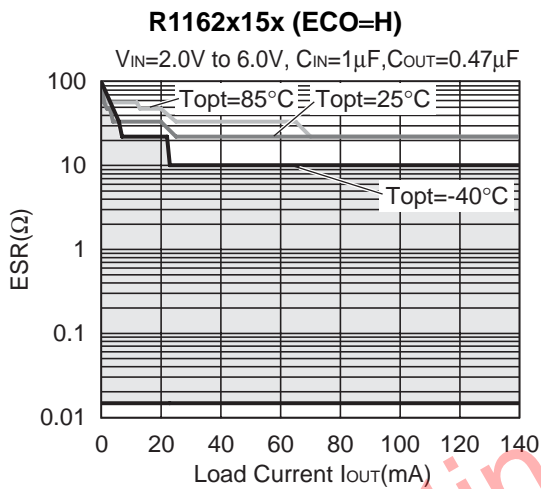



1. The products and the product specifications described in this document are subject to change or discontinuation of production without notice for reasons such as improvement. Therefore, before deciding to use the products, please refer to Ricoh sales representatives for the latest information thereon.
2. The materials in this document may not be copied or otherwise reproduced in whole or in part without prior written consent of Ricoh.
3. Please be sure to take any necessary formalities under relevant laws or regulations before exporting or otherwise taking out of your country the products or the technical information described herein.
4. The technical information described in this document shows typical characteristics of and example application circuits for the products. The release of such information is not to be construed as a warranty of or a grant of license under Ricoh's or any third party's intellectual property rights or any other rights.
5. The products listed in this document are intended and designed for use as general electronic components in standard applications (office equipment, telecommunication equipment, measuring instruments, consumer electronic products, amusement equipment etc.). Those customers intending to use a product in an application requiring extreme quality and reliability, for example, in a highly specific application where the failure or misoperation of the product could result in human injury or death (aircraft, spacevehicle, nuclear reactor control system, traffic control system, automotive and transportation equipment, combustion equipment, safety devices, life support system etc.) should first contact us.
6. We are making our continuous effort to improve the quality and reliability of our products, but semiconductor products are likely to fail with certain probability. In order to prevent any injury to persons or damages to property resulting from such failure, customers should be careful enough to incorporate safety measures in their design, such as redundancy feature, fire containment feature and fail-safe feature. We do not assume any liability or responsibility for any loss or damage arising from misuse or inappropriate use of the products.
7. Anti-radiation design is not implemented in the products described in this document.
8. The X-ray exposure can influence functions and characteristics of the products. Confirm the product functions and characteristics in the evaluation stage.
9. WLCSP products should be used in light shielded environments. The light exposure can influence functions and characteristics of the products under operation or storage.
10. There can be variation in the marking when different AOI (Automated Optical Inspection) equipment is used. In the case of recognizing the marking characteristic with AOI, please contact Ricoh sales or our distributor before attempting to use AOI.
11. Please contact Ricoh sales representatives should you have any questions or comments concerning the products or the technical information.



**Ricoh is committed to reducing the environmental loading materials in electrical devices with a view to contributing to the protection of human health and the environment.**

Ricoh has been providing RoHS compliant products since April 1, 2006 and Halogen-free products since April 1, 2012.

**RICOH** RICOH ELECTRONIC DEVICES CO., LTD.

<https://www.e-devices.ricoh.co.jp/en/>

#### Sales & Support Offices

##### **Ricoh Electronic Devices Co., Ltd.**

##### **Shin-Yokohama Office (International Sales)**

2-3, Shin-Yokohama 3-chome, Kohoku-ku, Yokohama-shi, Kanagawa, 222-8530, Japan  
Phone: +81-50-3814-7687 Fax: +81-45-474-0074

##### **Ricoh Americas Holdings, Inc.**

675 Campbell Technology Parkway, Suite 200 Campbell, CA 95008, U.S.A.  
Phone: +1-408-610-3105

##### **Ricoh Europe (Netherlands) B.V.**

##### **Semiconductor Support Centre**

Prof. W.H. Keesomlaan 1, 1183 DJ Amstelveen, The Netherlands  
Phone: +31-20-5474-309

##### **Ricoh International B.V. - German Branch**

##### **Semiconductor Sales and Support Centre**

Oberrather Strasse 6, 40472 Düsseldorf, Germany  
Phone: +49-211-6546-0

##### **Ricoh Electronic Devices Korea Co., Ltd.**

3F, Haesung Bldg, 504, Teheran-ro, Gangnam-gu, Seoul, 135-725, Korea  
Phone: +82-2-2135-5700 Fax: +82-2-2051-5713

##### **Ricoh Electronic Devices Shanghai Co., Ltd.**

Room 403, No.2 Building, No.690 Bibo Road, Pu Dong New District, Shanghai 201203,  
People's Republic of China  
Phone: +86-21-5027-3200 Fax: +86-21-5027-3299

##### **Ricoh Electronic Devices Shanghai Co., Ltd.**

##### **Shenzhen Branch**

1205, Block D (Jinlong Building), Kingkey 100, Hongbao Road, Luohu District,  
Shenzhen, China  
Phone: +86-755-8348-7600 Ext 225

##### **Ricoh Electronic Devices Co., Ltd.**

##### **Taipei office**

Room 109, 10F-1, No.51, Hengyang Rd., Taipei City, Taiwan (R.O.C.)  
Phone: +886-2-2313-1621/1622 Fax: +886-2-2313-1623