

## 5A Ultra Low Dropout Voltage Regulator Fast Response, Adjustable & Fixed

### FEATURES

- Low Dropout Voltage 500mV at 5A Full Load Current
- Adjustable Output Down to 1.2V from ATX Power Supply
- Fixed Output Voltages of 3.3V, 2.8V and 2.5V
- Extremely Tight Load and Line Regulation
- Standard 5-Terminal Low Cost TO-220 and TO-263

### APPLICATIONS

- 3.3V to 2.8V ATX Power Supplies
- 3.3V to 2.9V for Portable PENTIUM™ Processor
- 5V to 3.5V VRE Supply
- High efficiency "Green" Computer Systems

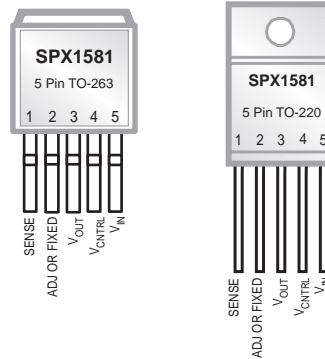

Now Available in Lead Free Packaging

### DESCRIPTION

The SPX1581 is a 5A Low Dropout Regulator with extremely low dropout voltage. The adjustable version requires only two external resistors to set the output voltage. The fixed version has a preset output of 3.3V, 2.8V or 2.5V and does not require any external resistors. The SPX1581 features a low dropout of 400mV(Typ.) and offers fast transient response. This device is suitable for Pentium applications requiring 2.8V, 2.5V from 3.3V ATX power supplies, where a low current input voltage 1V greater than the output voltage is needed. With an external sense pin the load regulation is less than 1mV. This device is an excellent choice for the use of powering low voltage microprocessors that require a lower dropout, fast transient response to regulate from 3.3V and 5V supplies. The SPX1581 is also an excellent choice as a post regulator for switching supplies applications.

The SPX1581 offers protection against over-current faults, reversed input polarity, over temperature operation and positive and negative transient voltage.

The SPX1581 is offered in a 5 pin TO-220 and TO-263 compatible with industry standard 5-terminal regulators. For 7A, 3A and 1.5A ultra low dropout versions refer to SPX1580, SPX1582 and SPX1583 data sheets respectively.

### TYPICAL APPLICATIONS CIRCUIT

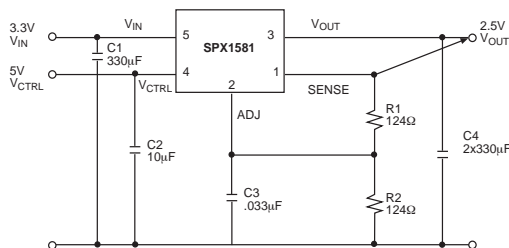

- (1)  $V_{CTRL}$  needed when  $V_{IN} < 5V$ .
- (2)  $V_{OUT} = V_{REF} (1+R_2/R_1) + ADJ \cdot R_2$ .
- (3)  $V_{REF}$  is measured across adjust to sense.

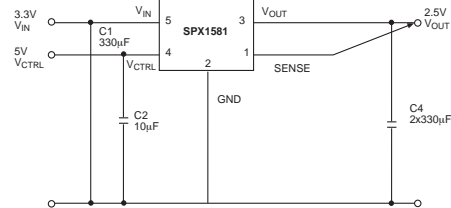

- (1)  $V_{CTRL}$  needed when  $V_{IN} < 5V$ .

Adjustable Regulator

Typical Fixed Regulator

## ABSOLUTE MAXIMUM RATINGS

Power Dissipation ..... Internally Limited  
 Storage Temperature Range ..... -65°C to +150°C

Input Supply Voltage ..... 6V  
 $V_{CTRL}$  Input Voltage ..... 13V

Operating Junction Temperature Range  
 SPX1581 Control Section ..... 0°C to +125°C  
 SPX1581 Power Transistor ..... 0°C to +150°C

## ELECTRICAL CHARACTERISTICS

Electrical characteristics at  $V_{OUT} = V_{SENSE}$ ,  $V_{ADJ} = 0V$ ,  $T_A = 25^\circ C$ ,  $C_{CTL} = C_{PWR} = C_{OUT} = 33\mu F$  tantalum cap otherwise specified. The  $\blacklozenge$  denotes the specifications which apply over full temperature range -40°C to +85°C, unless otherwise specified.

PARAMETER	MIN	TYP	MAX	UNITS	$\blacklozenge$	CONDITIONS
<b>2.5V Version</b>						
Output Voltage	2.450 2.400	2.5	2.550 2.600	V		$V_{CTRL} = 6.0V$ to 12V, $V_{IN} = 3.0V$ to 5.0V, $I_O = 10mA$ $\blacklozenge$ $I_O = 10mA$ to 5A
<b>2.8V Version</b>						
Output Voltage	2.744 2.688	2.8	2.856 2.912	V		$V_{CTRL} = 6.3V$ to 12V, $V_{IN} = 3.3V$ to 12V, $I_O = 10mA$ $\blacklozenge$ $I_O = 10mA$ to 5A
<b>3.3V Version</b>						
Output Voltage	3.234 3.168	3.3	3.366 3.432	V		$V_{CTRL} = 6.3V$ to 12V, $V_{IN} = 3.3V + 0.8V$ , $I_O = 10mA$ $\blacklozenge$ $I_O = 10mA$ to 5A
<b>All Voltage Options</b>						
Reference Voltage	1.238	1.25	1.263	V		$V_{CTRL} = 2.75V$ , $V_{IN} = 2.00V$ , $I_O = 10mA$ $V_{CTRL} = 2.7V$ to 12V, $V_{IN} = 2.05V$ to 5.5V, $I_O = 10mA$ to 5A
Line Regulation		1.0	3.0	mV	$\blacklozenge$	$V_{CTRL} = 2.5V$ to 12V, $V_{IN} = 1.75V$ to 5.5V, $I_O = 10mA$ $V_{ADJ} = 0V$
Load Regulation (Note 1)		1.0	5.0	mV	$\blacklozenge$	$V_{CTRL} = 2.75V$ , $V_{IN} = 2.1V$ , $I_O = 10mA$ to 5A, $V_{ADJ} = 0V$
Dropout Voltage Min. $V_{CTRL}$ (Note 2) ( $V_{CTRL} - V_{OUT}$ )		1.10	1.25	V		$V_{ADJ} = 0V$ $V_{IN} = 2.05V$ , $I_O = 1A$
Dropout Voltage Min. $V_{IN}$ (Note 2) ( $V_{IN} - V_{OUT}$ )		0.40	0.50	V		$V_{ADJ} = 0V$ $V_{IN} = 2.75V$ , $I_O = 5A$
Current Limit	5.1			A		$V_{CTRL} = 2.75V$ , $V_{IN} = 2.05V$ , $\Delta V_{OUT} = 100mV$ , $V_{ADJ} = 0V$
Minimum Load Current		5	10	mA	$\blacklozenge$	$V_{CTRL} = 5V$ , $V_{IN} = 3.3V$ , $V_{ADJ} = 0V$
Thermal Regulation		0.002	0.02	%/W		30ms Pulse
Ripple Rejection	60	80		dB		$V_{CTRL} = 3.75V$ , $V_{IN} = 3.75V$ , $I_O = 2.5A$ , $V_{ADJ} = 0V$ $T_J = 25$ , $V_{RIPPLE} = 1V_{pp}$ at 120Hz
Control Pin Current		60	120	mA	$\blacklozenge$	$V_{ADJ} = 0V$ $V_{CTRL} = 2.75V$ , $V_{IN} = 2.05V$ , $I_O = 5A$
Adjustble Pin Current		50	120	$\mu A$	$\blacklozenge$	$V_{CTRL} = 2.75V$ , $V_{IN} = 2.05V$ , $V_{ADJ} = 0V$ , $I_O = 10mA$
Thermal Resistance TO-220-5			3 50	$^\circ C/W$		Junction to Case ( $\theta_{JC}$ ) Junction to Ambient ( $\theta_{JA}$ )
Thermal Resistance TO-263-5			3 60	$^\circ C/W$		Junction to Case ( $\theta_{JC}$ ) Junction to Ambient ( $\theta_{JA}$ )

**Note 1:** Low duty cycle pulse testing with Kelvin connections is required in order to maintain accurate data.

**Note 2:** Dropout voltage is defined as the minimum differential between  $V_{IN}$  and  $V_{OUT}$  or  $V_{CTRL}$  and  $V_{OUT}$  required to maintain regulation at  $V_{OUT}$  95% Nominal  $V_{OUT}$ .

**Note 3:**  $V_{REF}$  is measured across Adjust pin to Sense pin.

PIN NUMBER	PIN NAME	DESCRIPTION
1	SENSE	Allows Kelvin sense of $V_{OUT}$ at the load. (Positive side of the reference voltage of the device).
2	ADJ	Negative side of the reference voltage for the device. Adding a small bypass capacitor from the ADJ pin to ground will improve the transient response.
3	$V_{OUT}$	Power output of the device.
4	$V_{CTRL}$	Supply pin for the control circuitry of the device. The current flow into this pin will be about 1% of the output current. $V_{CTRL}$ must be between 1.0V and 1.3V greater than the output voltage for the device to regulate.
5	$V_{IN}$	Output load current is supplied through this pin. $V_{IN}$ must be between 0.1V and 0.8V greater than the output voltage for this device to regulate.

Note that TAB is internally connected to Pin 3.

**FUNCTIONAL DIAGRAM**

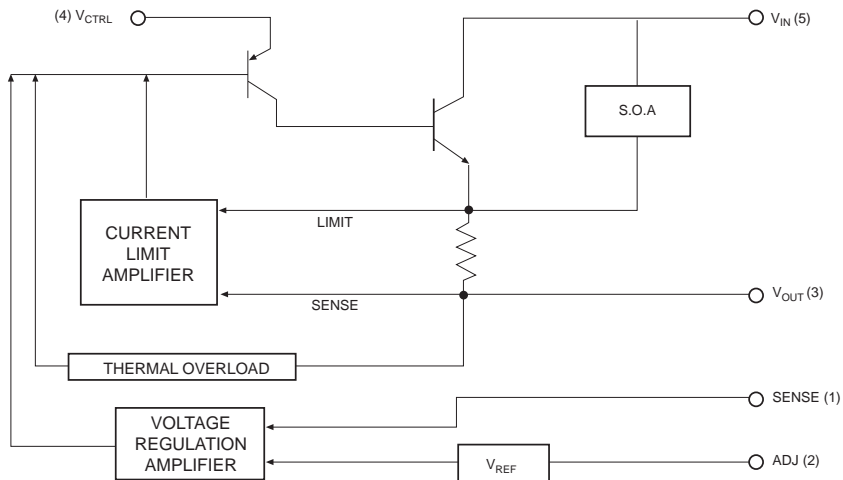

The SPX1581 is designed as a high performance and low cost solution for application requiring a lower dropout than traditional NPN regulators.

The SPX1581 uses a separate input voltage  $V_{CTRL}$  ( $V_{CTRL} \geq V_{OUT} + 1.3V$ ) to minimize the dropout voltage. This allows the 2.5V power for the load to come from a 3.3V system supply.

As added benefit this will reduce the heat dissipation\*, and lower heatsink and cooling fan cost.

A typical application would use 5V for  $V_{IN}$  and 3.3V for  $V_{CTRL}$  from a motherboard power supply to provide a nominal 2.5V output. Using the sense pin allows Kelvin measure the output, reducing resistance-associated errors.

The SPX1581 can power the 2.5V core voltage for microprocessors such as a Pentium™, P55C™, AMD5k86™ and K6™ and the IBM PowerPC™ 603EV and 604EV processors. Power sequencing of  $V_{IN}$  and  $V_{CTRL}$  is required. Apply  $V_{IN}$  before  $V_{CTRL}$  for proper operation

\* The reduction of heat dissipation is a result of the increase of the regulator efficiency ( $\text{efficiency} = V_{OUT}/V_{IN}$ ).

### Adjustable Regulator Design

1.25V reference voltage is being developed between the SENSE pin and the ADJ pin of the SPX1581. Adding two external resistors (see fig 1.) will allow setting the output voltage from 1.25V to 6V.  $R_1$  is chosen so that this current is specified minimum load current of 10mA.  $R_2$  is given by the formula:  $V_{OUT} = V_{REF} (1 + R_2/R_1) + I_{ADJ} (R_2)$ . The current flowing from the ADJ pin is typically 50 $\mu$ A. This ADJ pin contributes to the final  $V_{OUT}$  but is usually neglected.

Connecting the sense pin to the top of the resistor divider will improve load regulation.

### Lowering Noise

Using the SENSE pin to Kelvin the load will increase accuracy of the output voltage during load regulation. For the fixed voltage device, adding a capacitor at the GND pin will improve transient response. This capacitor is chosen in the range of 1 $\mu$ F to 0.1 $\mu$ F and will depend on the amount of output capacitance in the system.

### Power Up Sequencing

The SPX158x requires a power up sequence in that  $V_{IN}$  must applied before  $V_{CTRL}$  to prevent a latch up condition. If this is not possible then a series 10 $\Omega$  resistor should be added to the  $V_{CTRL}$  input to prevent the device from entering a latch up if  $V_{CTRL}$  is applied before  $V_{IN}$ .

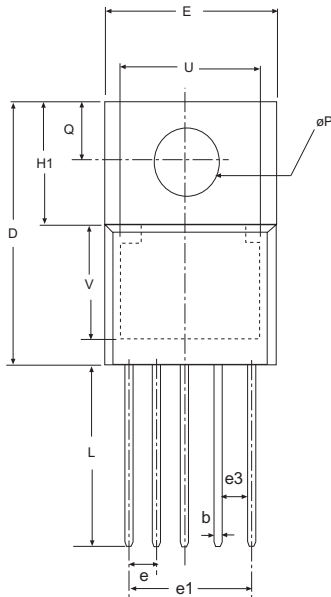

## Package Outline Drawing

POS	INCHES		MILLIMETERS	
	MIN	MAX	MIN	MAX
A	.160	.190	4.06	4.83
b	.025	.040	0.63	1.04
C1	.014	.022	0.36	0.56
D	.560	.590	14.22	14.99
E	.385	.415	9.78	10.54
e	.062	.072	1.57	1.83
e1	.263	.273	6.68	6.93
e3	.030	.040	0.76	1.02
F	.045	.055	1.14	1.40
H1	.234	.258	5.94	6.55
J1	.090	.115	2.29	2.92
phi P	.146	.156	3.71	3.96
Q	.103	.113	2.62	2.87
L	.540	.560	13.72	14.22
alpha	3°	7°	3°	7°
U	.30 REF		7.62 REF	
V	.24 REF		6.10 REF	

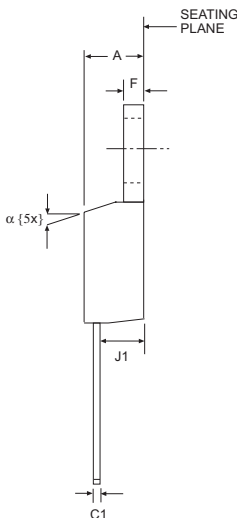

### NOTE:

1. DIMENSION C1 APPLY FOR TIN PLATE FINISH.
2. FOR SOLDER DIP LEAD FINISH, DIMENSION C1 SHOULD BE .015"-.027" (0.38-0.69MM).
3. J1 DIMENSION TO BE COVERED BY FINAL VISUAL OUTGOING SPEC, CSM-220-017 (L). Y-AXIS BEND LEAD ALLOWED FOR 1 LEAD THICKNESS.

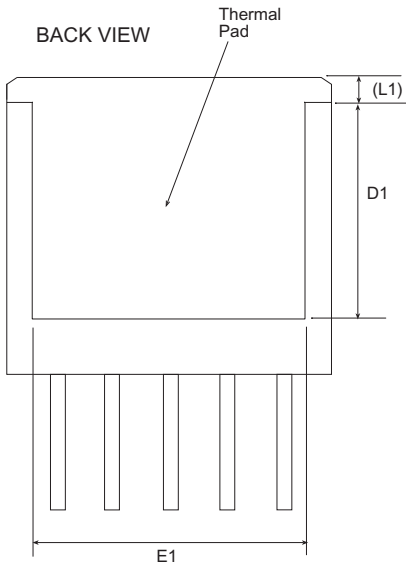
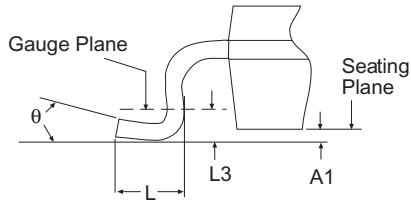
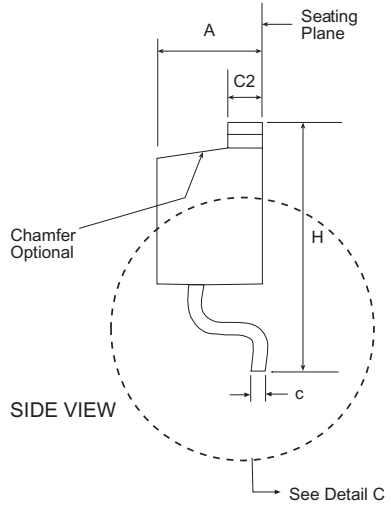
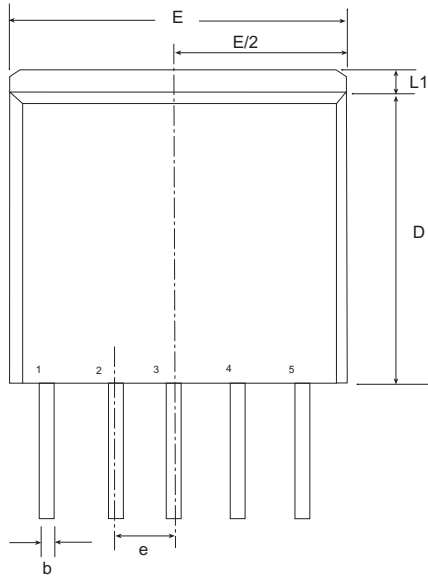

5 Pin TO-263 JEDEC TO-263			Variation BA			
SYMBOL	Inches Controlling Dimension			Millimeters Conversion Factor: 1 Inch = 25.40 mm		
	MIN	NOM	MAX	MIN	NOM	MAX
A	0.160	-	0.190	4.06	-	4.83
A1	0.000	-	0.010	0.00	-	0.25
b	0.020	-	0.039	0.51	-	0.99
c	0.015	-	0.029	0.38	-	0.74
c2	0.045	-	0.065	11.43	-	5.84
D	0.330	-	0.380	8.38	-	9.65
D1	0.270	-	-	6.86	-	-
E	0.380	-	0.420	9.65	-	10.67
E1	0.245	-	-	6.22	-	-
e	.067 BSC			17.02 BSC		
H	0.575	-	0.625	14.61	-	15.88
L	0.070	-	0.110	1.78	-	2.79
L1	-	-	0.066	-	-	1.68
L3	.010 BSC			2.54 BSC		
Q	0°	-	8°	0°	-	8°
SIPEX Pkg Signoff Date/Rev:				JL Jan18-06/Rev A		

Part Number	Accuracy	Output Voltage	Packages
SPX1581U5 .....	2.0% .....	Adj .....	5-Pin TO-220
SPX1581U5-2-5 .....	2.0% .....	2.5V .....	5-Pin TO-220
SPX1581U5-2-8 .....	2.0% .....	2.8V .....	5-Pin TO-220
SPX1581U5-3-3 .....	2.0% .....	3.3V .....	5-Pin TO-220
SPX1581T5 .....	2.0% .....	Adj .....	5-Pin TO-263
SPX1581T5/TR .....	2.0% .....	Adj .....	5-Pin TO-263
SPX1581T5-2-5 .....	2.0% .....	2.5V .....	5-Pin TO-263
SPX1581T5-2-5/TR .....	2.0% .....	2.5V .....	5-Pin TO-263
SPX1581T5-3-3 .....	2.0% .....	3.3V .....	5-Pin TO-263
SPX1581T5-3-3/TR .....	2.0% .....	3.3V .....	5-Pin TO-263

Available in lead free packaging. To order add "-L" suffix to part number.

Example: SPX1581T5-3-3/TR = standard; SPX1581T5-L-3-3/TR = lead free

/TR = Tape and Reel

Pack quantity is 500 for TO-263.



Solved by Sipex™

**Sipex Corporation**

**Headquarters and Sales Office**

233 South Hillview Drive  
 Milpitas, CA 95035  
 TEL: (408) 934-7500  
 FAX: (408) 935-7600

Sipex Corporation reserves the right to make changes to any products described herein. Sipex does not assume any liability arising out of the application or use of any product or circuit described herein; neither does it convey any license under its patent rights nor the rights of others.