

# OPTIREG™ linear TLE4276

## Low drop voltage regulator



### Features

- 5 V and variable output voltage
- Output voltage tolerance  $\leq \pm 4\%$
- 400 mA current capability
- Low drop voltage
- Inhibit input
- Very low current consumption
- Short-circuit-proof
- Reverse polarity proof
- Suitable for use in automotive electronics
- Green Product (RoHS compliant)

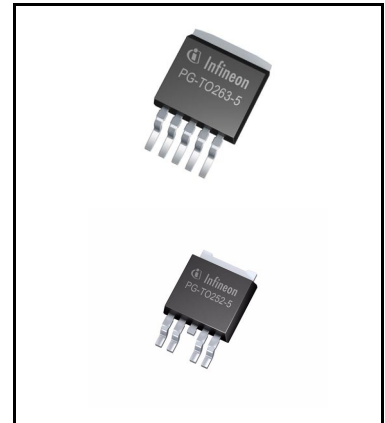

### Potential applications

Automotive applications especially with tight space constraints.

### Product validation

Qualified for automotive applications. Product validation according to AEC-Q100/101.

### Description

The OPTIREG™ linear TLE4276 is a low-drop voltage regulator in a TO package. The IC regulates an input voltage up to 40 V to  $V_{Q,nom} = 5.0$  V (V50), and adjustable voltage (V). The maximum output current is 400 mA. The IC can be switched off via the inhibit input, which causes the current consumption to drop below 10  $\mu$ A. The IC is short-circuit-proof and includes temperature protection which turns off the device at overtemperature.

Type	Package	Marking
TLE4276GV50	PG-T0263-5	4276V50
TLE4276GV	PG-T0263-5	4276V
TLE4276DV50	PG-T0252-5	4276V50
TLE4276DV	PG-T0252-5	4276V

## Table of Contents

<b>1</b>	<b>Block diagram</b> .....	<b>3</b>
<b>2</b>	<b>Pin configuration</b> .....	<b>4</b>
2.1	Pin assignments .....	4
<b>3</b>	<b>Functional description</b> .....	<b>5</b>
3.1	Typical performance graphs .....	11
<b>4</b>	<b>Package information</b> .....	<b>13</b>
<b>5</b>	<b>Revision history</b> .....	<b>14</b>



**Pin configuration**

**2 Pin configuration**

**2.1 Pin assignments**

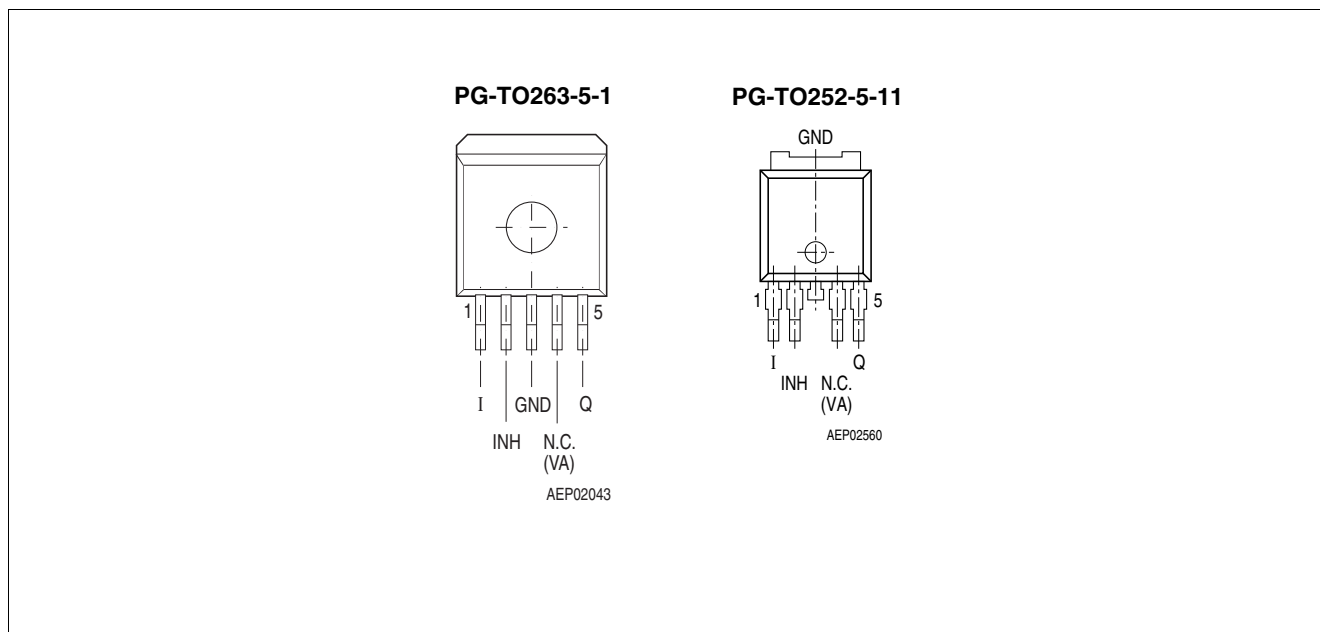

**Figure 2 Pin configuration** (top view)

**Table 1 Pin definitions and functions**

Pin No.	Symbol	Function
1	I	<b>Input;</b> block to ground directly at the IC with a ceramic capacitor.
2	INH	<b>Inhibit;</b> low-active input.
3	GND	<b>Ground</b>
4	N.C. VA	<b>Not connected</b> for V50 <b>Voltage adjust Input;</b> only for adjustable version. Connect an external voltage divider to determine the output voltage.
5	Q	<b>Output;</b> block to GND with a $\geq 22 \mu\text{F}$ capacitor, $\text{ESR} \leq 3 \Omega$ at 10 kHz
Heatsink		Connect to GND.

## **3 Functional description**

### **Functional description**

The OPTIREG™ linear TLE4276 is a low-drop voltage regulator in a TO package. The IC regulates an input voltage up to 40 V to  $V_{Q,nom} = 5.0$  V (V50), and adjustable voltage (V). The maximum output current is 400 mA. The IC can be switched off via the inhibit input, which causes the current consumption to drop below 10  $\mu$ A. The IC is short-circuit-proof and includes temperature protection which turns off the device at overtemperature.

### **Dimensioning information on external components**

The input capacitor  $C_I$  is necessary for compensation of line influences. Using a resistor of approx. 1  $\Omega$  in series with  $C_I$ , the oscillating of input inductivity and input capacitance can be damped. The output capacitor  $C_O$  is necessary for the stability of the regulation circuit. The stability is guaranteed at values  $C_O \geq 22$   $\mu$ F and an ESR of  $\leq 3$   $\Omega$  within the operating temperature range.

### **Circuit description**

The control amplifier compares a reference voltage to a voltage that is proportional to the output voltage and drives the base of the series transistor via a buffer. Saturation control as a function of the load current prevents any oversaturation of the power element. The IC also incorporates a number of internal circuits for protection against:

- Overload
- Overtemperature
- Reverse polarity

**Functional description**

**Table 2 Absolute maximum ratings**

Parameter	Symbol	Limit Values		Unit	Test Condition
		Min.	Max.		
<b>Input I</b>					
Voltage	$V_I$	-42	45	V	-
Current	$I_I$	-	-	-	Internally limited
<b>Inhibit INH</b>					
Voltage	$V_{INH}$	-42	45	V	-
<b>Voltage adjust input VA</b>					
Voltage	$V_{VA}$	-0.3	10	V	-
<b>Output Q</b>					
Voltage	$V_Q$	-1.0	40	V	-
Current	$I_Q$	-	-	-	Internally limited
<b>Ground GND</b>					
Current	$I_{GND}$	-	100	mA	-
<b>Temperature</b>					
Junction temperature	$T_j$	-40	150	°C	-
Storage temperature	$T_{stg}$	-50	150	°C	-

*Note: Maximum ratings are absolute ratings; exceeding any one of these values may cause irreversible damage to the integrated circuit.*

**Table 3 ESD rating**

Parameter	Symbol	Limit Values		Unit	Notes
		Min.	Max.		
ESD capability	$V_{ESD,HBM}$	2000	-	V	Human body model

**Functional description**

**Table 4 Operating range**

Parameter	Symbol	Limit Values		Unit	Remarks
		Min.	Max.		
Input voltage	$V_I$	$V_Q + 0.5$	40	V	Fixed voltage devices V50
Input voltage	$V_I$	$V_Q + 0.5$	40	V	Variable device V
Input voltage	$V_I$	4.5 V	40	V	Variable device V, $V_Q < 4$ V
Junction temperature	$T_j$	-40	150	°C	-

**Thermal resistance**

Junction ambient	$R_{thj-a}$	-	80	K/W	1)
Junction case	$R_{thj-c}$	-	4	K/W	-

1) Package mounted on PCB 80 × 80 × 1.5 mm; 35 μ Cu; 5 μ Sn; Footprint only; zero airflow.

**Functional description**

**Table 5 Electrical characteristics**

$V_I = 13.5 \text{ V}$ ;  $-40 \text{ °C} < T_j < 150 \text{ °C}$  (unless otherwise specified)

Parameter	Symbol	Limit Values			Unit	Measuring Condition	Measuring Circuit
		Min.	Typ.	Max.			
Output voltage	$V_Q$	4.8	5.0	5.2	V	V50-version $5 \text{ mA} < I_Q < 400 \text{ mA}$ $6 \text{ V} < V_I < 28 \text{ V}$	1
Output voltage	$V_Q$	4.8	5.0	5.2	V	V50-version $5 \text{ mA} < I_Q < 200 \text{ mA}$ $6 \text{ V} < V_I < 40 \text{ V}$	1
Output voltage tolerance	$\Delta V_Q$	-4	-	4	%	V-version $R_2 < 50 \text{ k}\Omega$ $V_Q + 1 \text{ V} \leq V_I \leq 40 \text{ V}$ $V_I > 4.5 \text{ V}$ $5 \text{ mA} \leq I_Q \leq 400 \text{ mA}$	1
Output current limitation <sup>1)</sup>	$I_Q$	400	600	1100	mA	-	1
Current consumption; $I_q = I_I - I_Q$	$I_q$	-	-	10	$\mu\text{A}$	$V_{\text{INH}} = 0 \text{ V}$ ; $T_j \leq 100 \text{ °C}$	1
Current consumption; $I_q = I_I - I_Q$	$I_q$	-	100	220	$\mu\text{A}$	$I_Q = 1 \text{ mA}$	1
Current consumption; $I_q = I_I - I_Q$	$I_q$	-	5	10	mA	$I_Q = 250 \text{ mA}$	1
Current consumption; $I_q = I_I - I_Q$	$I_q$	-	15	25	mA	$I_Q = 400 \text{ mA}$	1
Drop voltage <sup>1)</sup>	$V_{\text{DR}}$	-	250	500	mV	V50 $I_Q = 250 \text{ mA}$ $V_{\text{DR}} = V_I - V_Q$	1
Drop voltage <sup>1)</sup>	$V_{\text{DR}}$	-	250	500	mV	V-version devices $I_Q = 250 \text{ mA}$ $V_I > 4.5 \text{ V}$ $V_{\text{DR}} = V_I - V_Q$	1
Load regulation	$\Delta V_{Q,\text{Lo}}$	-	5	35	mV	$I_Q = 5 \text{ mA to } 400 \text{ mA}$	1
Line regulation	$\Delta V_{Q,\text{Li}}$	-	15	25	mV	$\Delta V_I = 12 \text{ V to } 32 \text{ V}$ $I_Q = 5 \text{ mA}$	1
Power supply ripple rejection	PSRR	-	54	-	dB	$f_r = 100 \text{ Hz}$ ; $V_r = 0.5 \text{ Vpp}$	1
Temperature output voltage drift	$\Delta V_Q/dT$	-	0.5	-	-	-	mV/K



**Functional description**

**Table 5 Electrical characteristics (cont'd)**

$V_I = 13.5\text{ V}$ ;  $-40\text{ °C} < T_j < 150\text{ °C}$  (unless otherwise specified)

Parameter	Symbol	Limit Values			Unit	Measuring Condition	Measuring Circuit
		Min.	Typ.	Max.			
<b>Inhibit</b>							
Inhibit on voltage	$V_{INH}$	–	2	3.5	V	$V_Q \geq 4.9\text{ V}$	1
Inhibit off voltage	$V_{INH}$	0.5	1.7	–	V	$V_Q \leq 0.1\text{ V}$	1
Input current	$I_{INH}$	5	10	20	$\mu\text{A}$	$V_{INH} = 5\text{ V}$	1

1) Measured when the output voltage  $V_Q$  has dropped 100 mV from the nominal value obtained at  $V_I = 13.5\text{ V}$ .

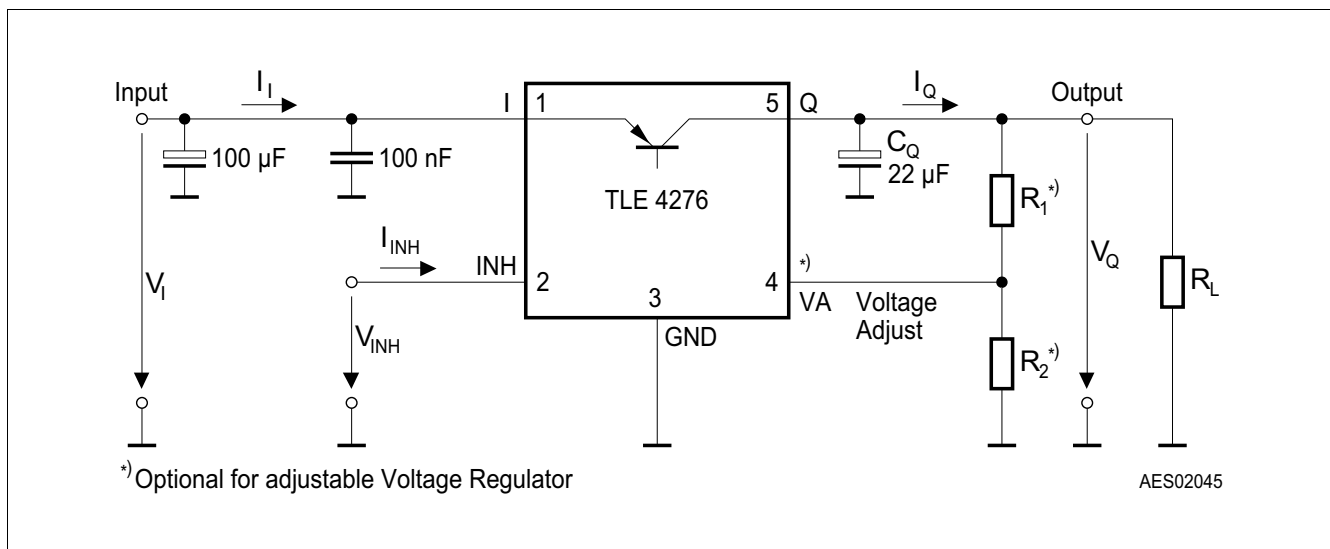

**Figure 3 Measuring circuit**

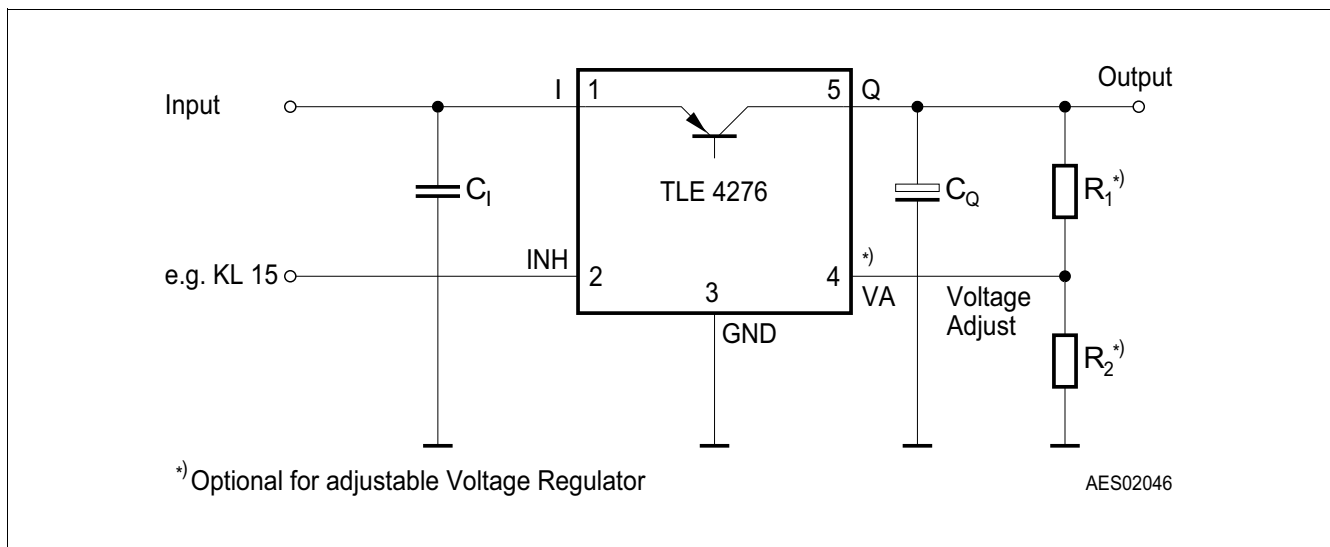

**Figure 4 Application circuit**

**Functional description**

**Application information for variable output regulator TLE4276V**

The output voltage of the TLE4276V can be adjusted between 2.5 V and 20 V by an external output voltage divider, closing the control loop to the voltage adjust pin VA.

The voltage at pin VA is compared to the internal reference of typical 2.5 V in an error amplifier. It controls the output voltage.

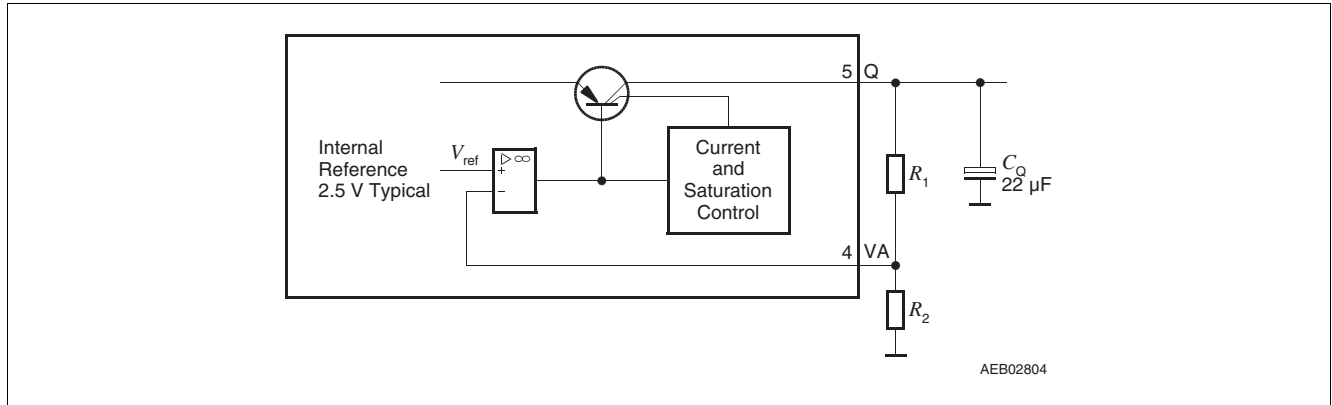

**Figure 5 Application detail external components at output for variable voltage regulator**

The output voltage is calculated according to **Equation (3.1)**:

$$V_Q = (R_1 + R_2)/R_2 \times V_{ref}, \text{ neglecting } I_{VA} \quad (3.1)$$

$V_{ref}$  is typically 2.5 V.

To avoid errors caused by leakage current  $I_{VA}$ , we recommend to choose the resistor value  $R_2$  according to **Equation (3.2)**:

$$R_2 < 50 \text{ k}\Omega \quad (3.2)$$

For a 2.5 V output voltage the output pin Q is directly connected to the adjust pin VA.

The accuracy of the resistors  $R_1$  and  $R_2$  add an additional error to the output voltage tolerance.

The operation range of the variable TLE4276V is  $V_Q + 0.5 \text{ V}$  to 40 V. For internal biasing a minimum input voltage of 4.3 V is required. For output voltages below 4 V the voltage drop is  $4.3 \text{ V} - V_Q$ .

**Functional description**

**3.1 Typical performance graphs**

**Typical performance characteristics V50**

**Voltage  $V_{DR}$  versus output current  $I_Q$**

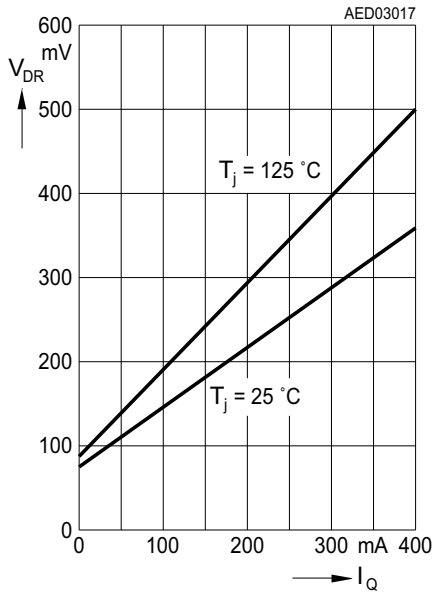

**Current consumption  $I_Q$  versus output current  $I_Q$  (high load)**

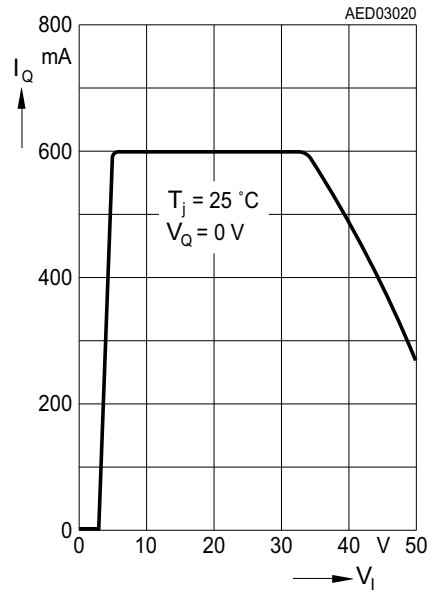

**Max. output current  $I_Q$  versus input voltage  $V_I$**

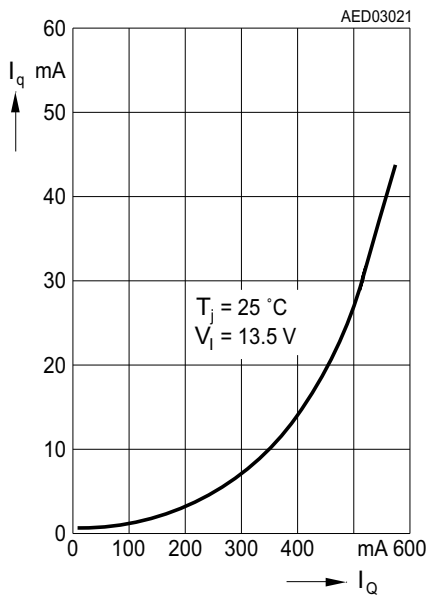

**Current consumption  $I_Q$  versus output current  $I_Q$  (low load)**

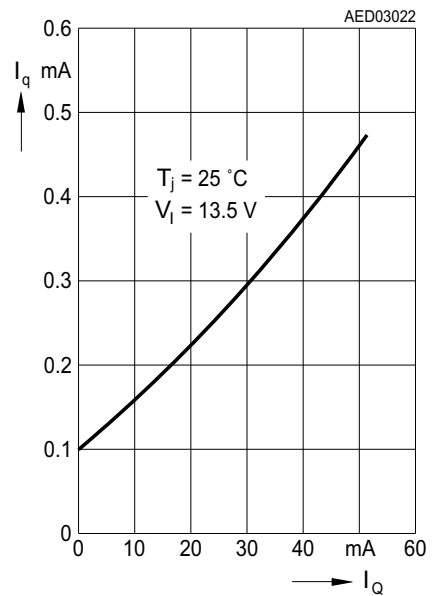

**Functional description**

**Output voltage  $V_Q$  versus temperature  $T_J$**

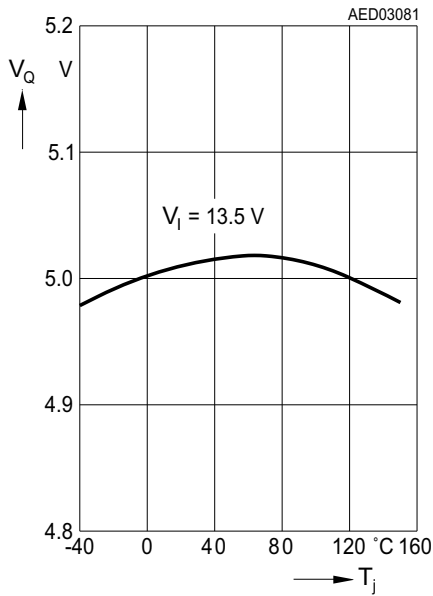

**Current consumption  $I_q$  versus input voltage  $V_I$**

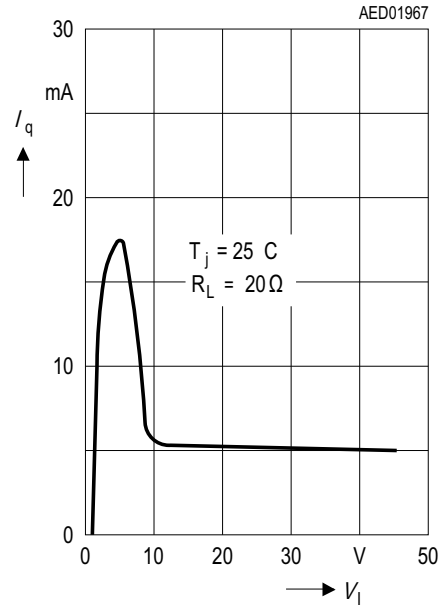

**Low voltage behavior**

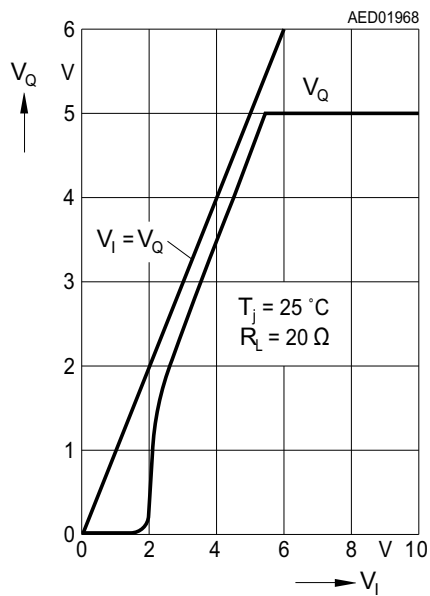

**High voltage behavior**

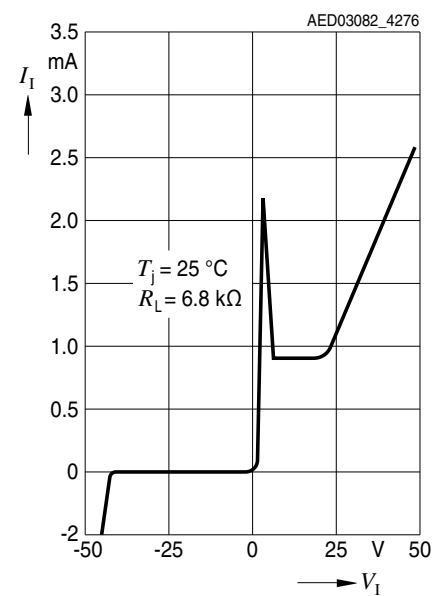

## 4 Package information

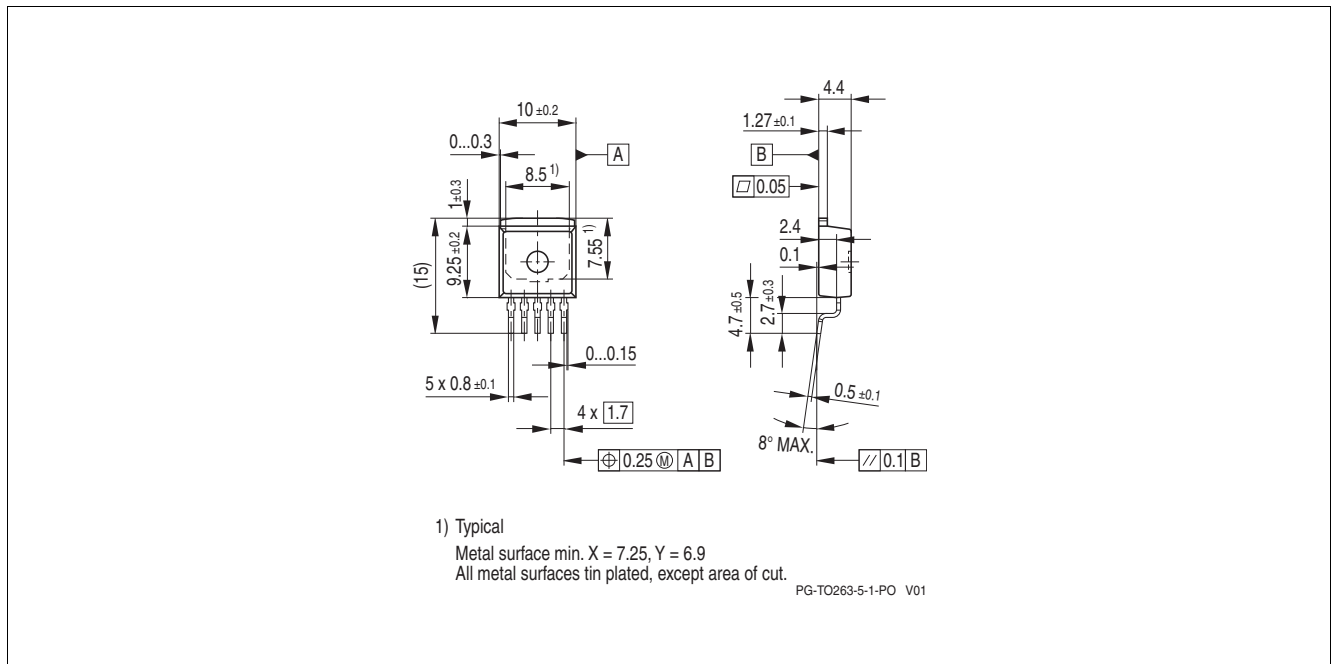

**Figure 6 PG-TO263-5<sup>1)</sup>**

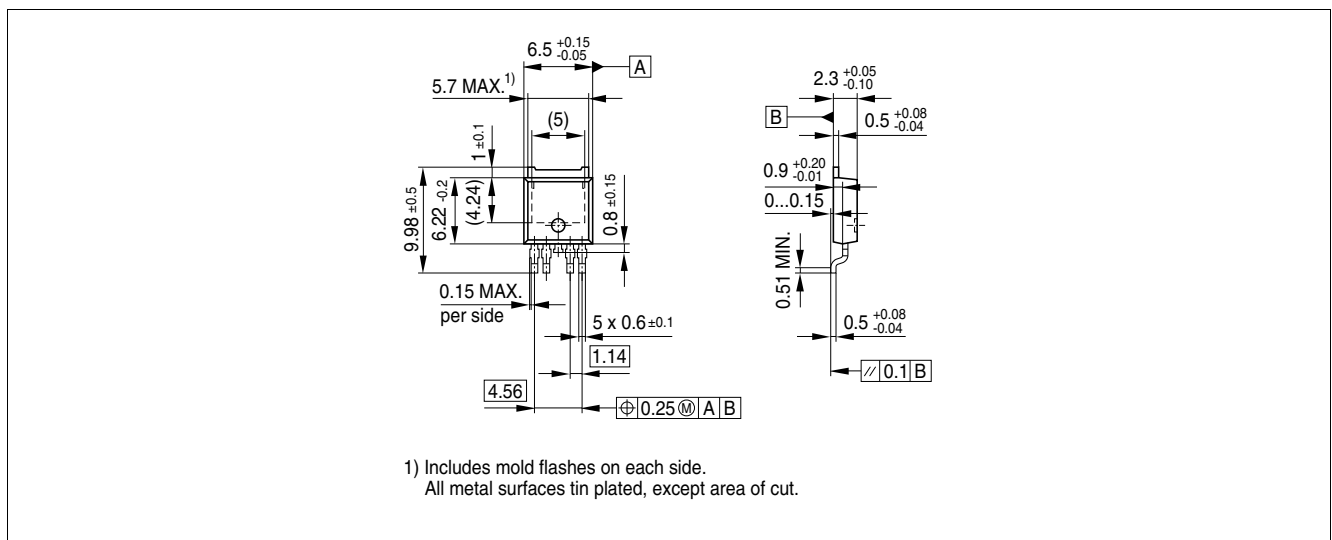

**Figure 7 PG-TO252-5<sup>1)</sup>**

### Green Product (RoHS compliant)

To meet the world-wide customer requirements for environmentally friendly products and to be compliant with government regulations the device is available as a green product. Green products are RoHS-Compliant (i.e Pb-free finish on leads and suitable for Pb-free soldering according to IPC/JEDEC J-STD-020).

### Further information on packages

<https://www.infineon.com/packages>

1) Dimensions in mm

**Revision history**

## **5 Revision history**

<b>Revision</b>	<b>Date</b>	<b>Changes</b>
2.90	2023-06-28	TLE4276SV, package PG-TO220-5 removed (discontinued) Editorial changes
2.81	2019-05-22	Updated layout (OPTIREG™)
2.80	2018-01-10	Deleted obsolete products: TLE4276V50, TLE4276V85, TLE4276V10, TLE4276SV50, TLE4276SV85, TLE4276GV85 and TLE4276GV10 Updated template

## Trademarks

All referenced product or service names and trademarks are the property of their respective owners.

**Edition 2023-06-28**

**Published by**

**Infineon Technologies AG**

**81726 Munich, Germany**

**© 2023 Infineon Technologies AG.**

**All Rights Reserved.**

**Do you have a question about any aspect of this document?**

**Email: [erratum@infineon.com](mailto:erratum@infineon.com)**

**Document reference**

**Z8F55294382**

## IMPORTANT NOTICE

The information given in this document shall in no event be regarded as a guarantee of conditions or characteristics ("Beschaffheitsgarantie").

With respect to any examples, hints or any typical values stated herein and/or any information regarding the application of the product, Infineon Technologies hereby disclaims any and all warranties and liabilities of any kind, including without limitation warranties of non-infringement of intellectual property rights of any third party.

In addition, any information given in this document is subject to customer's compliance with its obligations stated in this document and any applicable legal requirements, norms and standards concerning customer's products and any use of the product of Infineon Technologies in customer's applications.

The data contained in this document is exclusively intended for technically trained staff. It is the responsibility of customer's technical departments to evaluate the suitability of the product for the intended application and the completeness of the product information given in this document with respect to such application.

For further information on technology, delivery terms and conditions and prices, please contact the nearest Infineon Technologies Office ([www.infineon.com](http://www.infineon.com)).

## WARNINGS

Due to technical requirements products may contain dangerous substances. For information on the types in question please contact your nearest Infineon Technologies office.

Except as otherwise explicitly approved by Infineon Technologies in a written document signed by authorized representatives of Infineon Technologies, Infineon Technologies' products may not be used in any applications where a failure of the product or any consequences of the use thereof can reasonably be expected to result in personal injury.