

Multilayer Ceramic Chip Capacitors

江苏芯声微电子科技有限公司

Jiangsu Holy Ram Electronics

Technology Limited

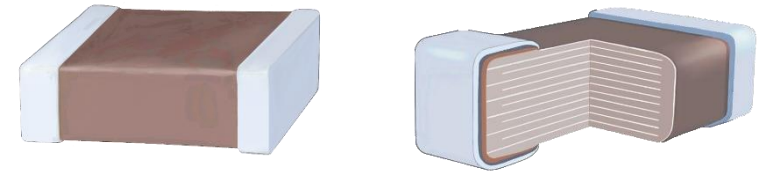

CAI Series (Automotive Grade)

Material	X7R	C0G
Temp. Range	-55°C--125°C	-55°C--125°C
Cap.Tolerance	±15%	±30ppm/°C





PRECAUTIONS FOR USE

Please attach the purchase specification before using this product.

SAFETY INFORMATION

Please pay attention to safety precautions when using this product.

Limitation of Applications

Please contact us before using our products for the applications listed below which require especially high reliability for the prevention of defects which might directly cause damage to the third party's life, body or property.

- ①Aircraft equipment
- ②Aerospace equipment
- ③Undersea equipment
- ④Power plant control equipment
- ⑤Medical equipment
- ⑥Transportation equipment(vehicles,trains,ships,etc.)
- ⑦Traffic signal equipment
- ⑧Disaster prevention / crime prevention equipment
- ⑨Data-processing equipment
- ⑩Application of similar complexity and/or

Methods of transportation and storage

1.Transportation:

Packaged products suitable for modern transportation, in the process of transportation to prevent rain and acid and alkali corrosion, gravity throwing and force extrusion.

2.Storage:

The storage period to ensure good weldability of the product is one year from the date of production. Do not open the braid before use of the product (in the case of packaging and delivery). After the braid is opened, the product should be used within three months.

storage temperature: 0°C~35°C

Storage relative humidity:<70%

Characteristic

- complies with AEC-Q200 standard
- conforms to the MSL class :MSL 1
- complies with vehicle regulation J-STD-020D
- High reliability and equipment reliability
- Pass 100% six-sided photosynthesis test

Application

- car audio and video
- Body electronics
- High reliability
- Industrial applications

Product Structure Diagram

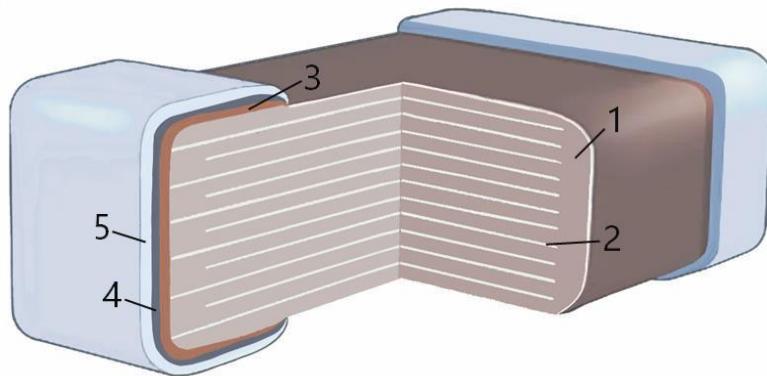

Serial number	Designation
1	Dielectric ceramics
2	Inner electrode (nickel)
3	Outer electrode (copper)
4	Nickel layer
5	Tin layer

Product model naming rules

EX: C AI 0402 X7R 104 K 500 G T
 (1) (2) (3) (4) (5) (6) (7) (8) (9)

(1)	C:MLCC			(5) Capacitance Value	Cap. > =10pF: First Two×10 ^{third} 104=10×10 ⁴ =100nF 123=12×10 ³ =12nF Cap. < 10pF: R30=0.3pF, 1R0=1pF													
(2) Application	AI:Automotive				(6) Capacitance Tolerance	A: ±0.05pF		B: ±0.1pF		C: ±0.25pF		D: ±0.5pF		F: ±1.0%				
(3) Size (L*W)	Coding	inch	Size(mm)	(7) Rate voltage Vdc		G: ±2%		J: ±5%		K: ±10%		M: ±20%		Z: 80/-20%				
	00R4	008004	0201		2R5:2.5		4R0:4.0		6R3:6.3		100:10		160:16		250:25			
	01R5	01005	0402		350:35		500:50		630:63		800:80		101:100		201:200			
	0201	0201	0603		251:250		401:400		451:450		501:500		631:630		102:1000			
	0402	0402	1005		202:2000		252:2500		302:3000		402:4000							
	0603	0603	1608		(8) Thickness (mm)		A:0.10		B:0.13		C:0.18		D:0.20		E:0.30		F:0.45	
	0805	0805	2012				G:0.50		H:0.60		J:0.80		K:0.85		L:1.15		M:1.25	
	1206	1206	3216				N:1.60		P:1.90		Q:2.00		R:2.50					
1210	1210	3225			(9) Packing						T: Finished product packaging (7" Reel)							
1808	1808	4520																
1812	1812	4532																
(4) Temperature Characteristic	COG X7R																	

Size & Packing Specifications

Generally, a $\Phi 180\text{mm}$ (7") tray is used for packing.

Each 5 disks is packed into a box, and each 12 boxes is a whole box.

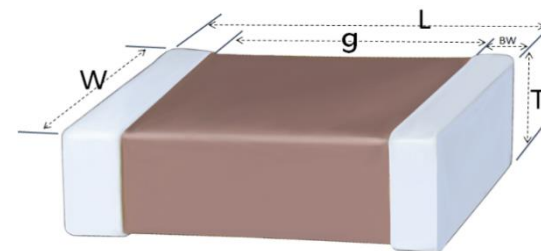

规格	Size (mm)				Packing (7")	
	Length	Width	Thickness	g	Number (star)	Method
0201	0.60±0.03	0.30±0.03	0.30±0.03	0.20	15,000	Paper tape
0402	1.00±0.05	0.50±0.05	0.50±0.05	0.30	10,000	Paper tape
0603	1.60±0.10	0.80±0.10	0.80±0.10	0.30	4,000	Paper tape
0805	2.00±0.20	1.25±0.20	0.85±0.20	0.50	4,000	Paper tape
			1.25±0.20		3,000/2,000	Plastic tape
1206	3.20±0.20	1.60±0.20	0.85±0.20	1.00	4,000	Paper tape
			1.25±0.20		3,000/2,000	Plastic tape
			1.60±0.20		2,000	Plastic tape
1210	3.20±0.40	2.50±0.30	1.25±0.30	1.00	3,000	Plastic tape
			1.60±0.30		2,000	
			2.50±0.30		1,000	

*** Plz refer to the single specification for details**

Capacitance Range 【COG】 0402~0805

Size (inch)	Thick (Code)	RV (Vdc)	1pF			10pF						100pF						1nF						10nF
			1R0	2R2	4R7	100	150	220	330	470	680	101	151	221	331	471	681	102	152	222	332	472	682	103
0402	0.50 (G)	25																						
		50																						
0603	0.80 (J)	25																						
		50																						
		100																						
0805	0.60 (H)	25																						
		50																						
	0.85 (K)	25																						
		50																						
	1.25 (M)	25																						
		50																						

【X7R】 0201~1210

Size (inch)	Thick (Code)	RV (Vdc)	150pF				1nF				15nF			100nF			1uF			10uF
			151	221	331	681	102	152	332	682	153	333	473	104	224	474	105	225	475	106
0201	0.30 (E)	16 25					■	■												
0402	0.50 (G)	6.3																		
		16	■	■	■	■	■	■	■	■	■	■	■	■	■	■	■	■	■	
		25	■	■	■	■	■	■	■	■	■	■	■	■	■	■	■	■	■	
		50	■	■	■	■	■	■	■	■	■	■	■	■	■	■	■	■	■	
100	■	■	■	■	■	■	■	■	■	■	■	■	■	■	■	■	■	■		
0603	0.80 (J)	10																		
		16					■	■	■	■	■	■	■	■	■	■	■	■	■	■
		25					■	■	■	■	■	■	■	■	■	■	■	■	■	■
		50	■	■	■	■	■	■	■	■	■	■	■	■	■	■	■	■	■	■
100	■	■	■	■	■	■	■	■	■	■	■	■	■	■	■	■	■	■		
0805	0.85 (K)	16																		
		25																		
		50					■	■	■	■	■	■	■	■	■	■	■	■	■	■
	100					■	■	■	■	■	■	■	■	■	■	■	■	■	■	■
	250					■	■	■	■	■	■	■	■	■	■	■	■	■	■	■
	1.25 (M)	6.3																		
10																				
16																				
25																				
50																				
100										■	■	■	■	■	■	■	■	■	■	■
250									■	■	■	■	■	■	■	■	■	■	■	
1206	1.60 (N)	25																		
		50																		
		100																		
1210	2.00 (Q)	50																		
		100																		
	2.50 (R)	25																		
		50																		

Specifications and Test Methods

No	Item	Specification	Test Method(Ref. Standard:AEC—Q200)			
1	Pre-and-Post-Stress Electrical Test	--	--			
2	High Temperature Exposure (Storage)	Appearance	No defects or abnormalities.	Mounting method	Solder the capacitor on the test substrate	
		Cap. Change	Plz refer to the single specification	Test Temperature	150+/-3°C	
		Q or D.F.	Within the specified initial value	Test Time	1000+/-12h	
		I.R.	Within the specified initial value	Post-treatment	Let sit for 24+/-2hours at room temperature, then measure.	
3	Temperature Cycling	Appearance	No defects or abnormalities.	Mounting method	Solder the capacitor on the test substrate	
				Pre-treatment	Perform a heat treatment at 150+0/-10°C for 1hour and then let sit for 24+/-2hours at room temperature, then measure.	
		Cap. Change	Plz refer to the single specification	Cycles	1000 cycles	
				Temperature Cycling:		
		Q or D.F.	Within the specified initial value	Step	Temperature (°C)	Time (min)
				1	Min. Operating Temp.+0/-3	30+/-3
				2	Room Temperature	1
		I.R.	Within the specified initial value	3	Max. Operating Temp.+3/-0	30+/-3
4	Room Temperature			1		
Post-treatment	Let sit for 24+/-2hours at room temperature, then measure					

Specifications and Test Methods

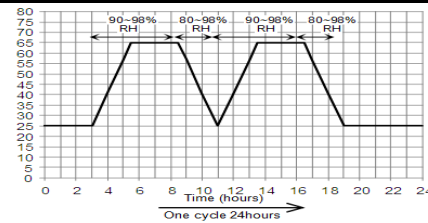
No	Item	Specification	Test Method(Ref. Standard:AEC—Q200)
4	DPA	Appearance No defects or abnormalities.	Per EIA-469
5	Moisture Resistance	Appearance No defects or abnormalities.	Mounting method Solder the capacitor on the test substrate
		Cap. Change Plz refer to the single specification	Test Temperature +25°C to +65°C
		Q or D.F. Within the specified initial value	Test Humidity 80% to 98% R.H.
		I.R. Within the specified initial value	Test Time Apply the 24h treatment shown below, 10 consecutive times.
			Temperature and Humidity cycle: 
	Post-treatment Let sit for 24+/-2hours at room temperature, then measure		
6	Biased Humidity	Appearance No defects or abnormalities.	Mounting method Solder the capacitor on the test substrate
		Cap. Change Plz refer to the single specification	Test Temperature 85+/-3°C
		Q or D.F. Within the specified initial value	Test Humidity 80% to 85% R.H.
		I.R. Within the specified initial value	Test Time 1000+/-12h
			Test Voltage 1. Rated voltage (not exceeding 630V) 2. Apply 1.5V (silver electrode) Connect the 100KΩ resistor
	Charge/discharge current 50mA max		
	Post-treatment Let sit for 24+/-2hours at room temperature, then measure		

Specifications and Test Methods

No	Item	Specification		Test Method(Ref. Standard:AEC—Q200)	
7	Operational Life	Appearance	No defects or abnormalities.	Mounting method	Solder the capacitor on the test substrate
		Cap. Change	Plz refer to the single specification	Test Temperature	Maximum Operating Temperature +/-3℃
		Q or D.F.	Within the specified initial value	Test Time	1000+/-12h
				Test Voltage (R.V.)	Plz refer to the single specification
		I.R.	Within the specified initial value	Charge/discharge current	50mA max
				Post-treatment	Let sit for 24+/-2hours at room temperature, then measure
8	Appearance	No defects or abnormalities.		Visual inspection	
9	Dimension	Shown in Dimension.		Using Measuring instrument of dimension	
10	Resistance to Solvents	Appearance	No defects or abnormalities.	Per MIL-STD-202 Method 215 (Only for the Mark points)	
		Cap. Change	Within the specified initial value		
		Q or D.F.	Within the specified initial value		
		I.R.	Within the specified initial value		
11	Mechanical Shock	Appearance	No defects or abnormalities.	Mounting method	Solder the capacitor on the test substrate
				Waveform	Half-sine
		Cap. Change	Within the specified initial value	Peak value	1500g
		Q or D.F.	Within the specified initial value	Holding Time	0.5ms
				Velocity change	4.7m/s
		I.R.	Within the specified initial value	Shocks directions and times	Three shocks in each direction should be applied along 3 mutually perpendicular axes of the test specimen (18 shocks).

Specifications and Test Methods

No	Item	Specification	Test Method(Ref. Standard:AEC—Q200)
12	Mechanical Vibration	Appearance	No defects or abnormalities.
		Cap. Change	Within the specified initial value
		Q or D.F.	Within the specified initial value
		I.R.	Within the specified initial value
13	Resistance to Soldering Heat	Appearance	No defects or abnormalities.
		Cap. Change	Within the specified initial value
		Q or D.F.	Within the specified initial value
		I.R.	Within the specified initial value
14	ESD	Appearance	No defects or abnormalities.
		Cap. Change	Within the specified initial value
		Q or D.F.	Within the specified initial value
		I.R.	Within the specified initial value

Mounting method	Kind of Vibration	Vibration Time	Total amplitude	Vibration directions and time
Solder the capacitor on the test substrate	A 10Hz ~ 2000Hz ~ 10Hz	20min	1.5mm	This motion should be applied for 12 items in each 3 mutually perpendicular directions (total of 36 times).

Test Method	Kind of Solder	Test Temperature	Test Time	Post-treatment
Solder bath method	Sn-3.0Ag-0.5Cu(Lead Free Solder)	260+/-5℃	10+/-1s	Let sit for 24+/-2hours at room temperature, then measure.

Per AEC-Q200-002

```

graph TD
    A[6 kV DC] -- FAIL --> B[2 kV DC]
    A -- PASS --> C[12 kV AD]
    B -- FAIL --> D[1 kV DC]
    B -- PASS --> E[4 kV DC]
    D -- FAIL --> F[500 V DC]
    D -- PASS --> G[1 kV DC]
    F -- FAIL --> H[< 500 V DC]
    F -- PASS --> I[500 V DC]
    E -- FAIL --> J[2 kV DC]
    E -- PASS --> K[4 kV DC]
    C -- FAIL --> L[8 kV DC]
    C -- PASS --> M[16 kV AD]
    L -- FAIL --> N[6 kV DC]
    L -- PASS --> O[8 kV DC]
    M -- FAIL --> P[12 kV AD]
    M -- PASS --> Q[25 kV AD]
    P -- FAIL --> R[16 kV AD]
    P -- PASS --> Q
    Q -- FAIL --> R
    Q -- PASS --> Q
    
```

Note: It is classified according to the highest level of electrostatic voltage under static test. Flow chart of passive component HBM anti-static test (DC = direct contact discharge, AD = air discharge)

Specifications and Test Methods

No	Item	Specification	Test Method(Ref. Standard:AEC—Q200)				
15	Solderability (a)	95% of the terminations is to be soldered evenly and continuously	Pre-treatment	Perform a heat treatment at 155°C			
			Flux	Solution of rosin ethanol 25(mass)%			
			Kind of Solder	Sn-3.0Ag-0.5Cu(Lead Free Solder)			
			Solder Temperature	Sn-3.0Ag-0.5Cu solder solution at 245+/-5 °C			
			Immersion time	5+0/-0.5s			
			Immersion and emersion rate	25+/-5mm/s			
16	Electrical Characterization	Capacitance	Shown in Rated value				
		Q or D.F.	Plz refer to the single specification	Test Temperature	25°C		
				Test Frequency	1.0+/-0.1MHz		
				Test Voltage	1.0±0.2Vrms		
		I.R.	Within the specified initial value	Test Temperature	25°C		
				Test Voltage	Plz refer to the single specification		
				Charging Time	1min		
				Charge/discharge current	50mA max		
		Voltage proof	No defects or abnormalities.	Material	Rate Voltage	Test Voltage	
					C0G	RV≤50V	300% RV
				50V < RV≤100V		250% RV	
				100V < RV≤250V		200% RV	
				250V < RV≤500V		150% RV	
				500V < RV≤1000V		130% RV	
X7R	RV≤100V			250% RV			
	100V < RV≤250V			200%RV			
	250V < RV≤630V			150% RV			
	630V < RV≤1000V			120% RV			

Specifications and Test Methods

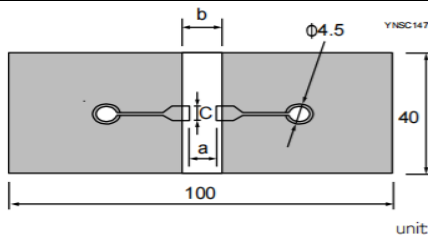
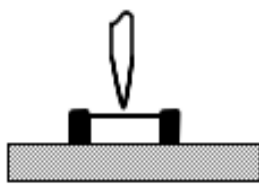
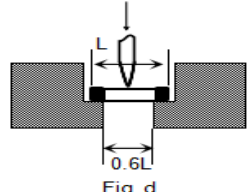
No	Item	Specification	Test Method(Ref. Standard:AEC—Q200)																											
17	Board Flex	Appearance	No defects or abnormalities.																											
		Cap. Change	Plz refer to the single specification																											
		Q or D.F.	Within the specified initial value																											
		I.R.	Within the specified initial value																											
				<div style="display: flex; align-items: center;">  <table border="1" style="margin-left: 20px;"> <thead> <tr> <th>尺寸</th> <th>a</th> <th>b</th> <th>c</th> </tr> </thead> <tbody> <tr> <td>0201</td> <td>0.3</td> <td>0.9</td> <td>0.3</td> </tr> <tr> <td>0402</td> <td>0.5</td> <td>1.5</td> <td>0.6</td> </tr> <tr> <td>0603</td> <td>0.6</td> <td>2.2</td> <td>0.9</td> </tr> <tr> <td>0805</td> <td>0.8</td> <td>3</td> <td>1.3</td> </tr> <tr> <td>1206</td> <td>2</td> <td>4.4</td> <td>1.7</td> </tr> <tr> <td>1210</td> <td>2</td> <td>4.4</td> <td>2.6</td> </tr> </tbody> </table> </div>	尺寸	a	b	c	0201	0.3	0.9	0.3	0402	0.5	1.5	0.6	0603	0.6	2.2	0.9	0805	0.8	3	1.3	1206	2	4.4	1.7	1210	2
尺寸	a	b	c																											
0201	0.3	0.9	0.3																											
0402	0.5	1.5	0.6																											
0603	0.6	2.2	0.9																											
0805	0.8	3	1.3																											
1206	2	4.4	1.7																											
1210	2	4.4	2.6																											
18	Terminal Strength	Appearance	No defects or abnormalities.																											
		Cap. Change	Within the specified initial value																											
		Q or D.F.	Within the specified initial value																											
		I.R.	Within the specified initial value																											
				<div style="display: flex; align-items: flex-start;"> <div style="margin-right: 20px;"> <p>Mounting method</p> <p>Solder the capacitor on the test substrate</p> </div> <div> <p>Applied Force</p> <p>keep applying 17.7N (1.8Kg)</p> <p>*0402 Apply 2N</p> <p>*0201 Apply 1N</p> <p>Note: Apply the force gradually so as not to impact the parts under test</p> </div> </div>																										
		<div style="display: flex; align-items: flex-start;"> <div style="margin-right: 20px;"> <p>Speed supplied the Stress Load 0.1mm/s</p> </div> <div> <p>Placement diagram:</p> <div style="display: flex; justify-content: space-around;"> <div style="text-align: center;"> <p>[Size L≤2.5mm]</p>  </div> <div style="text-align: center;"> <p>[Size L ≥ 3.2mm]</p>  </div> </div> <p>Fig. d</p> </div> </div>																												
19	Beam Load Test	<p>The tolerance should exceed the following values:</p> <table border="0" style="width: 100%;"> <tr> <td>Size L≤2.5mm</td> <td>Size L ≥ 3.2mm</td> </tr> <tr> <td>Thickness > 0.5mm:20N</td> <td>Thickness ≥ 1.25mm:54N</td> </tr> <tr> <td>Thickness ≤ 0.5mm:8N</td> <td>Thickness < 1.25mm:15N</td> </tr> </table>	Size L≤2.5mm	Size L ≥ 3.2mm	Thickness > 0.5mm:20N	Thickness ≥ 1.25mm:54N	Thickness ≤ 0.5mm:8N	Thickness < 1.25mm:15N																						
Size L≤2.5mm	Size L ≥ 3.2mm																													
Thickness > 0.5mm:20N	Thickness ≥ 1.25mm:54N																													
Thickness ≤ 0.5mm:8N	Thickness < 1.25mm:15N																													

Specifications and Test Methods

No	Item	Specification	Test Method(Ref. Standard:AEC—Q200)	
20	Temperature Characteristics of Capacitance	Cap. Change The nominal value of the temperature coefficient is shown in the rating. The change of capacitance at reference temperature is shown in Table A.	The capacitance change should be measured after 5 min at each specified temp. stage.	
			Capacitance value as a reference is the value in "*" marked step.	
			Cap. Change Tolerance changes are calculated by dividing the difference between the maximum and minimum values	
			Test Voltage Less than 1.0Vrms (Refer to the individual data sheet)	
		C0G: $\pm 30\text{ppm}/^\circ\text{C}$ X7R: $\pm 15\%$	Temperature Step: (A)	
			Step	Temperature
			1	Ref. Temperature: ± 2
			2	Min. Operating Temp.: ± 3
			3*	Ref. Temperature: ± 2
			4	Max. Operating Temp.: ± 3
5	Ref. Temperature: ± 2			

Product Packaging

At present, the most common way of packaging is to carry coil packaging. A coil with a diameter of 180mm (7") can contain 1000~20000 capacitors, or coil packaging can be carried out according to customer requirements.

1. Tape Size

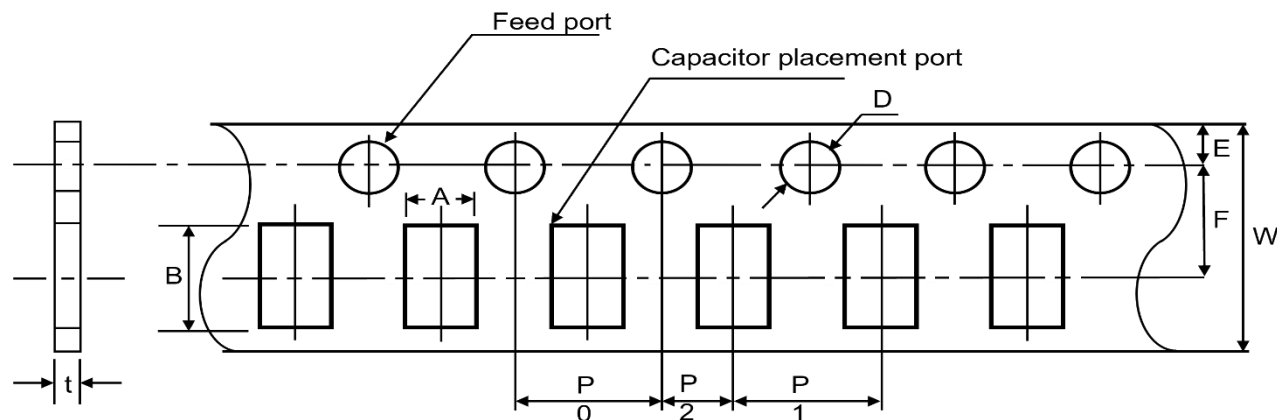

	01005 (0402)	0201 (0603)	0402 (1005)	0603 (1608)	0805 (2012)	1206 (3216)
P1	2.00±0.05(1.0 ±0.05)			4.00±0.10		
P0	4.00±0.10			4.00±0.10		
P2	2.00±0.05			2.00±0.05		
A	0.25±0.02	0.38±0.03	0.62±0.05	1.00±0.01	1.55±0.10	2.05±0.10
B	0.46±0.02	0.68±0.03	1.12±0.05	1.90±0.10	2.30±0.10	3.60±0.10
W	8.00±0.30			8.00±0.30		
E	1.75±0.10			1.75±0.10		
F	3.50±0.05			3.50±0.05		
D	φ1.50+0.10/-0.03			φ1.50+0.10/-0		
t	0.25±0.02	0.35±0.03	0.60±0.05	1.1Below		

2. Plastic Size

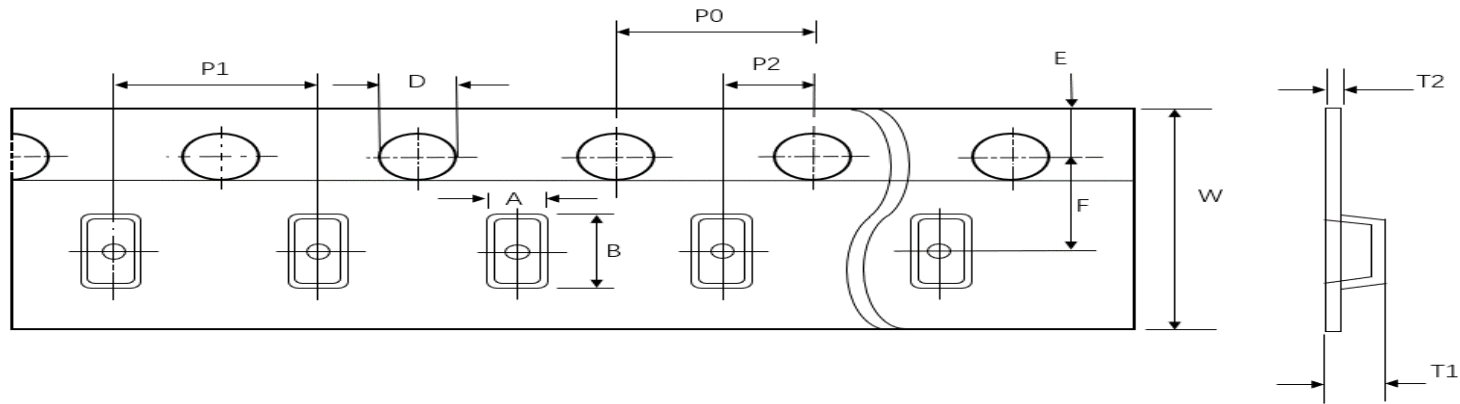

	0603 (1608)	0805 (2012)	1206 (3216)	1210 (3225)
P1	4±0.1	4±0.1	4±0.1	4±0.1
P0	4±0.1	4±0.1	4±0.1	4±0.1
P2	2±0.05	2±0.05	2±0.05	2±0.05
A	1.2±0.2	1.45±0.2	1.9±0.2	2.8±0.2
B	2.0±0.2	2.3±0.2	3.5±0.2	3.6±0.2
W	8±0.3	8±0.2	8±0.2	8±0.2
E	1.75±0.1	1.75±0.1	1.75±0.1	1.75±0.1
F	3.5±0.05	3.5±0.05	3.5±0.05	3.5±0.05
D	1.5 (+0.1/-0.0)	1.5 (+0.1/-0.0)	1.5 (+0.1/-0.0)	1.5 (+0.1/-0.0)
T1	1.4 max	2.5 max.	2.5 max.	2.5 max.
T2	0.25±0.1	0.305±0.1	0.30±0.1	0.30±0.1

3. Disk Size

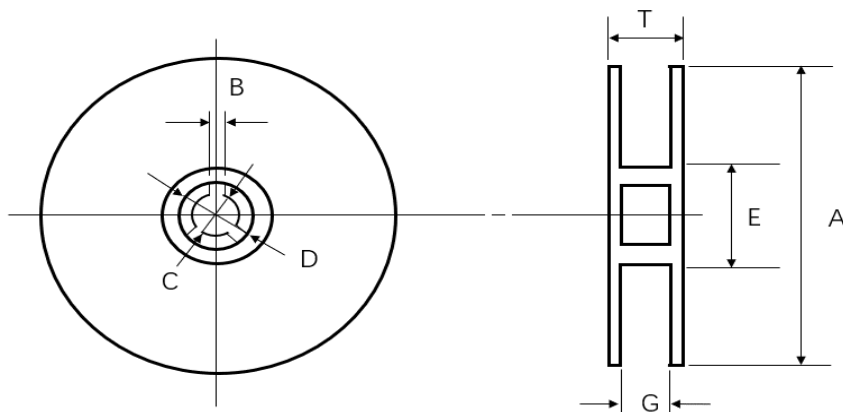

Disk Size	A (mm)	B (mm)	C (mm)	D (mm)	E (mm)	G (mm)	T (mm)
7"Reel	$\Phi 178 \pm 2.0$	2.0 ± 0.5	$\Phi 13 \pm 1.0$	$\Phi 21 \pm 0.8$	$\Phi 50$ 或更大	10 ± 1.0	13 ± 1.0

4. Instructions for use of reel tape

When the finished product is in use, the upper band (film) is at a speed of $300 \pm 10 \text{ mm/min}$, an Angle of $165^\circ \sim 180^\circ$ (as shown below), and the peeling strength is $0.1\text{N} \sim 0.7\text{N}$ ($10\text{g.f} \leq \text{peeling force} \leq 70\text{g.f}$).

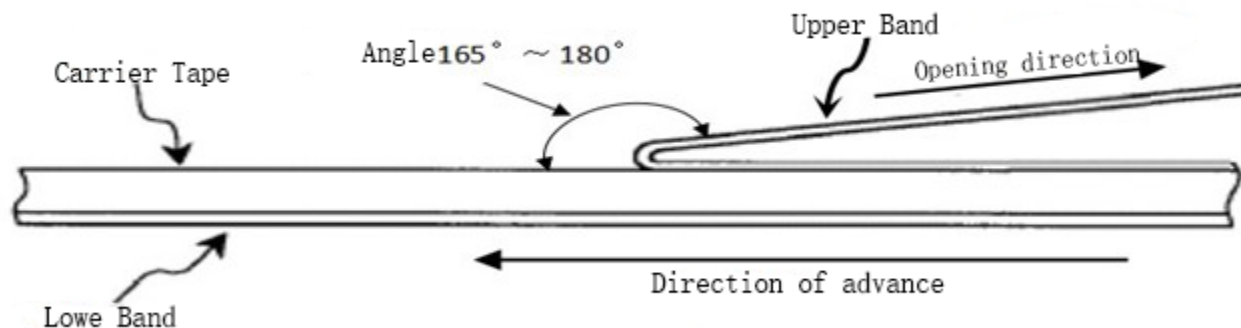

Precautions for use

Multi-layer Ceramic Chip Capacitors (MLCC) may have short circuit or open circuit under the harsh working environment beyond the use frequency described in this letter of admission or related instructions, or under the action of external mechanical force overpressure. Or it may smoke, burn or even explode, so when using, we should first consider to follow the relevant instructions in this acknowledgement, if there is anything unclear, please contact our technical department, Quality Control Department or production Department.

1. The amount of solder used in welding

A. Too much solder will cause capacitor damage due to excessive pressure at the capacitor end.



B. Too little solder fixed force is insufficient, may cause capacitor chip and line contact is poor.



2. Recommended amount of solder:

A. Optimal amount of solder for reflow welding

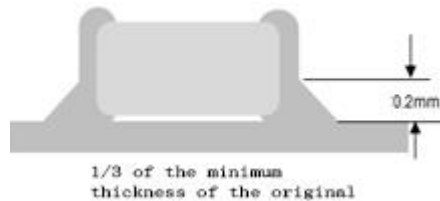

B. Optimum amount of solder for wave soldering

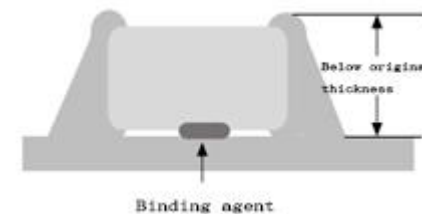

C. The optimal amount of solder used for repair with soldering iron



3. Recommended welding temperature curve:

Reflow welding

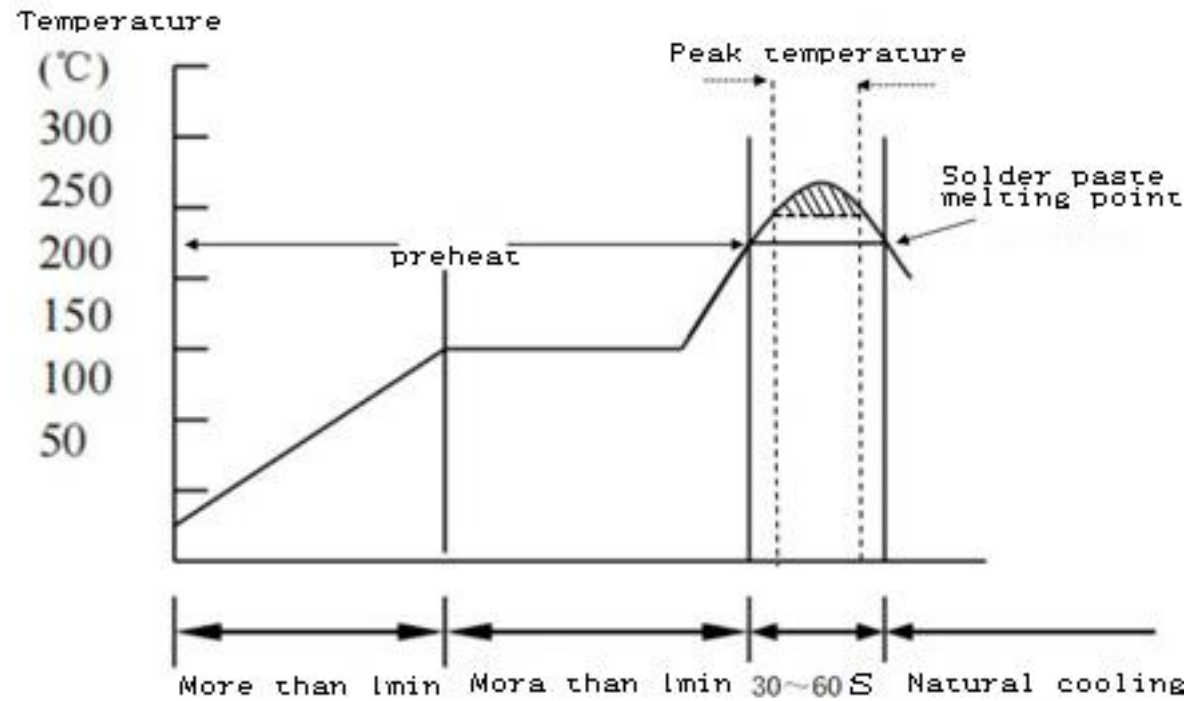

Solder type	Pb-Sn welding	Lead-free welding
Peak temperature	230°C ~ 250°C	240°C ~ 260°C
Peak time	3s ~ 10s	3s ~ 10s

Wave soldering

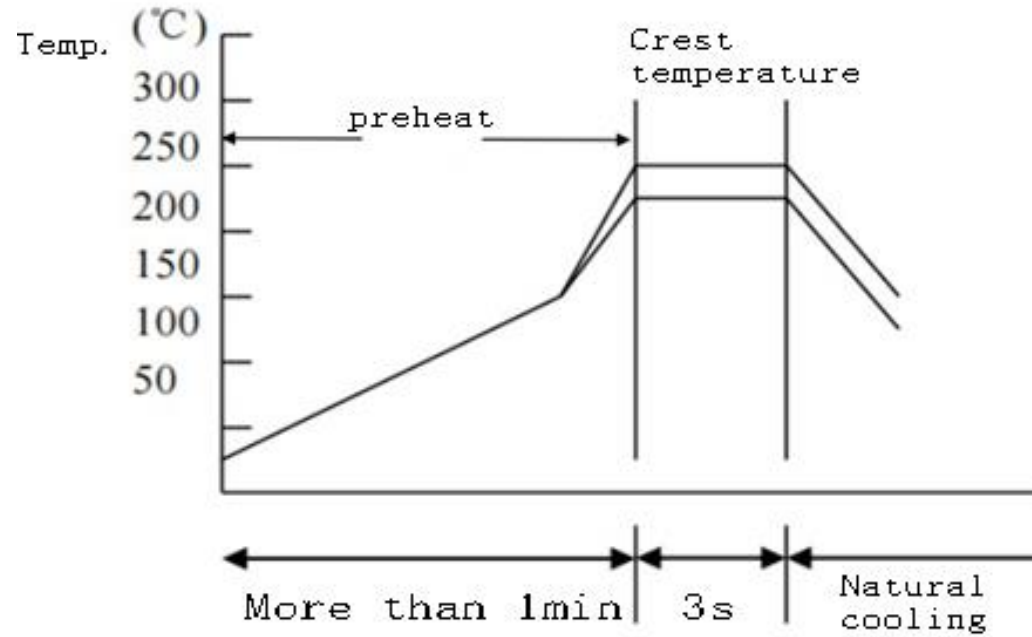

Solder type	Pb-Sn welding	Lead-free welding
Peak temperature	230°C ~ 260°C	240°C ~ 270°C
Peak time	Within 3s	Within 3s

Hand welding

Manual welding is easy to cause micro-cracking or partial cracking of porcelain because of uneven local heating of capacitor. Therefore, the use of electric iron manual welding should be carefully operated, and the choice of the tip of the electric branding iron and tip temperature control should be more careful.

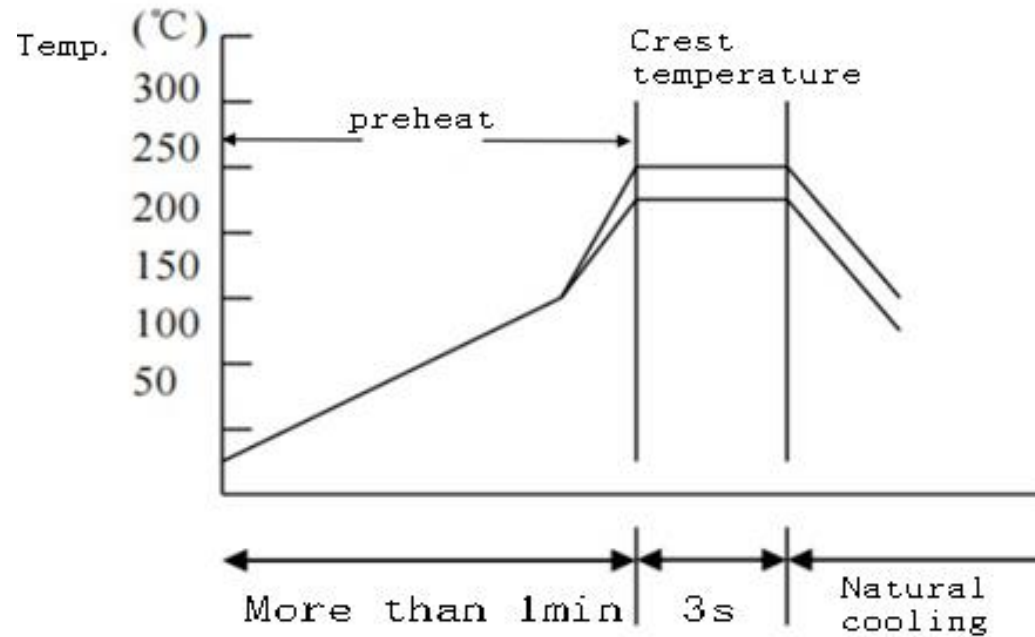

Preheat	Temperature	Power	Diameter	Time	Tin paste	Notice
$\Delta \leq 130^{\circ}\text{C}$	$\leq 350^{\circ}\text{C}$	$\leq 20\text{W}$	Recommended 1mm	$\leq 3\text{s}$	$\leq 1/2$ Capacitance height	Do not contact the iron head directly with the ceramic body

版本	修订日期	修订内容叙述
CAI-A-2023-01	2023/2/25	Initial issue
CAI-A-2023-02	2023/6/25	<ol style="list-style-type: none">1. Update the tolerance range legend2. Update the packaging quantity3. Update the Feature content