

3.0A,40V High Efficiency Synchronous Step-Down DC/DC Converter

Description

NDP14301KC is a high efficiency, monolithic synchronous step-down DC/DC converter utilizing a constant frequency, average current mode control architecture. Capable of delivering up to 3.0A continuous load with excellent line and load regulation. The device operates from an input voltage range of 4.6V to 36V and provides an adjustable output voltage from 3.3V to 25V.

The NDP14301KC features short circuit and thermal protection circuits to increase system reliability. The internal soft-start avoids input inrush current during startup.

The NDP14301KC require a minimum number of external components, and a wide array of protection features to enhance reliability.

Features

- Wide VIN Range : 4.6V to 36V
- 3.0A Continuous Output Current
- Up to 94% Efficiency
- CC/CV Mode Control
- 100% Max Duty Cycle
- Built in Adjustable Line-Compensation
- Adjustable Output Voltages
- $\pm 2\%$ Output Voltage Accuracy
- $\pm 5\%$ Current Limit Accuracy
- Integrated 56m Ω High Side Switch
- Integrated 29m Ω Low Side Switch
- Frequency(110KHz)
- Burst Mode Operation at Light Load
- Internal loop Compensation
- Internal Soft Start
- Available in SOP8 Package

Applications

- Car Charger
- Rechargeable Portable Devices
- Networking Systems
- Distributed Power Systems

Typical Application

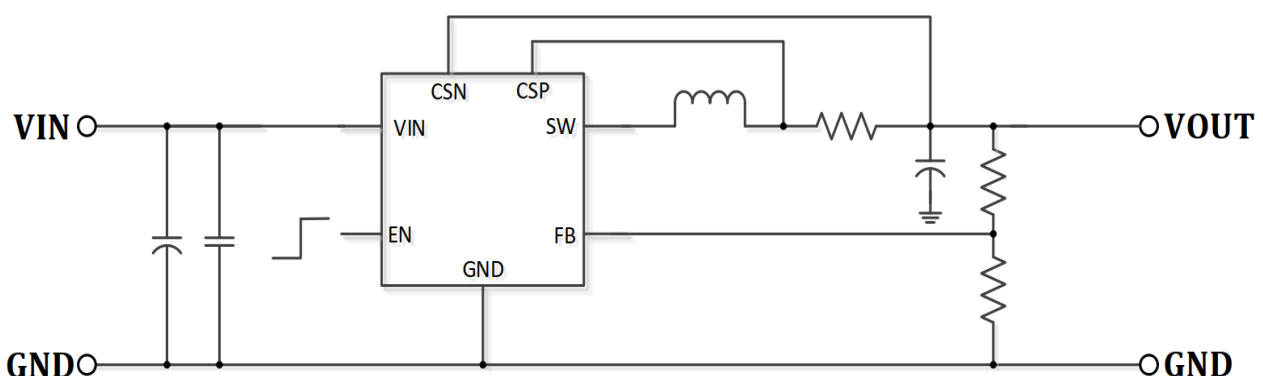

Note: When using a solid or ceramic input Cap, It is recommended to parallel a TVS diode.

Absolute Maximum Ratings (at TA = 25°C)

Characteristics	Symbol	Rating	Unit
VIN to GND		-0.3 to 42	V
SW to GND		-0.3 to VIN	V
FB, FS to GND		-0.3 to 6	V
CSP, CSN to GND		-0.3 to 25	V
Junction to Ambient Thermal Resistance		105	°C/W
Operating Junction Temperature		-40 to 150	°C
Storage Junction Temperature		-55 to 150	°C
Thermal Resistance from Junction to case	θ_{JC}	45	°C/W
Thermal Resistance from Junction to ambient	θ_{JA}	90	°C/W

Pin Function And Descriptions

PIN	NAME	Description
1	VFB	Feedback Of Output Voltage
2	CSP	Positive Pole of Current Sense
3	CSN	Negative Pole1 of Current Sense
4	VIN	Power Input Positive Pole
5,6	SW	Switching, Connected With a Inductor
7	EN	Enable internal pull up
8	GND	Ground

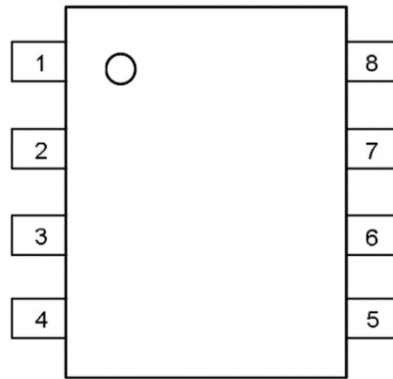

Order information

Order Information	Top Marking
<p>NDP14301 K C</p> <p>Pin NO. C:8</p> <p>Package K: SOP</p> <p>Product Number</p>	<p>NDP NDP14301KC DYYWWX</p> <p>DYY: Year(D22=2022,D23=2023,...) WW: Weekly (01-53) X : Internal ID Code</p>

Note : 1、Moisture sensitive level : MSL3.

2、After bag is opened, devices that will be subjected to reflow solder or other high temperature process must mounted within 168 hours of factory conditions <30°C/60% RH,or stored at <10%RH.

Electrical Characteristics

T_J = 25°C. V_{IN} = 12V, unless otherwise noted

Characteristics	Symbol	Conditions	Min	Typ	Max	Units
Input Voltage	V _{IN}		4.6	-	36	V
UVLO Voltage	V _{UVLO}			4.4		V
UVLO Hysteresis				0.7		V
Input over voltage protect	V _{ovp}		37	38	39	V
Quiescent Current	I _{CCQ}	No Switch(V _{in} =12V)	-	300	-	μA
Standby Current	I _{SB}	No Load(V _{in} =12V)	-	0.4	-	mA
Shut down Current	I _{SD}	V _{IN} =12V, EN=0V		45		μA
FB Reference Voltage	V _{FB}		0.980	1	1.020	V
V _{FB} bias Current	I _{FB}				0.2	μA
Current Sense AMP	V _{CS}	CSP-CSN	57	60	63	mV
VEN_H	EN Input High Voltage			1.2		V
VEN_L	EN Input Low Voltage			0.6		V
Switching Frequency	F _{SW}			110		KHz
Maximum Duty Cycle				100	-	%
Current Limit	I _{LIM}		3.3			A
Hicup Interval	T _{hiccup}			500		mS
Soft start Time	T _{SS}			2		mS
RDS _{ON} Of Power MOS	High side	Temp=25°C		56		mΩ
	Low side	Temp=25°C		29		mΩ
Thermal Regulation	T _{TR}			150		°C
Thermal shutdown Temp	T _{SD}		-	165	-	°C
Thermal Shutdown Hysteresis	T _{SH}		-	30	-	°C

Block Diagram

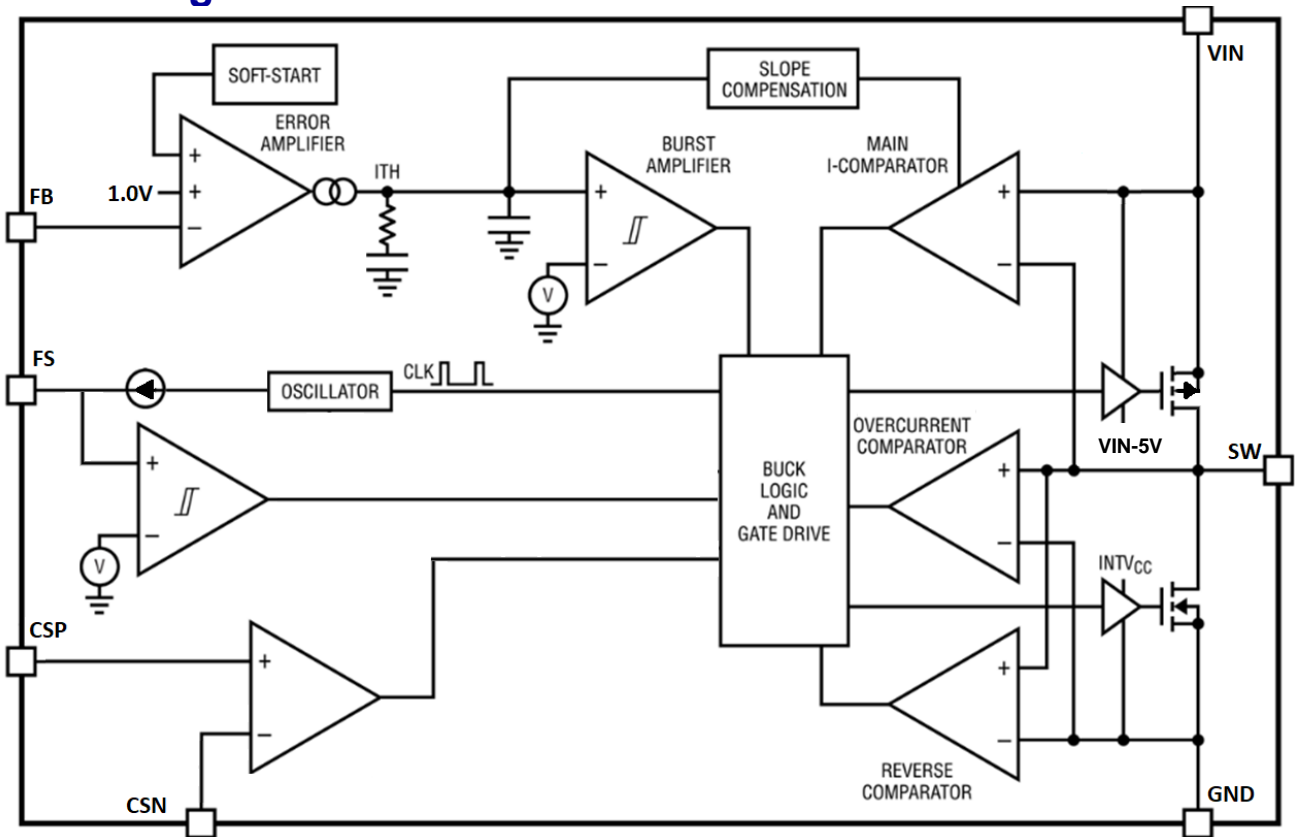

Typical Performance Characteristics (T_J = 25°C, unless otherwise noted)

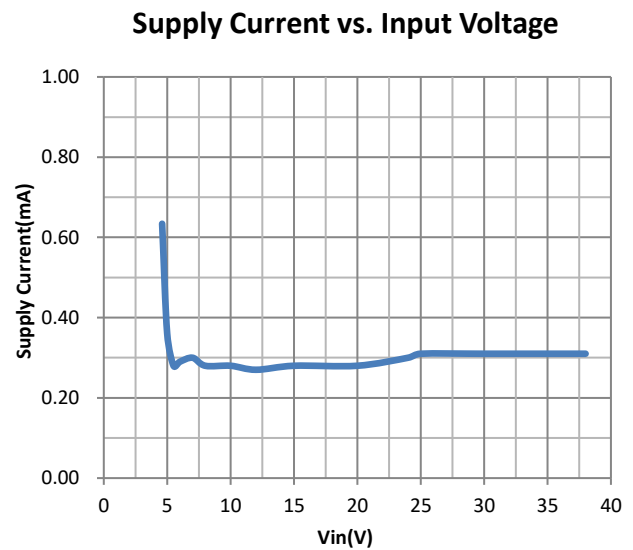
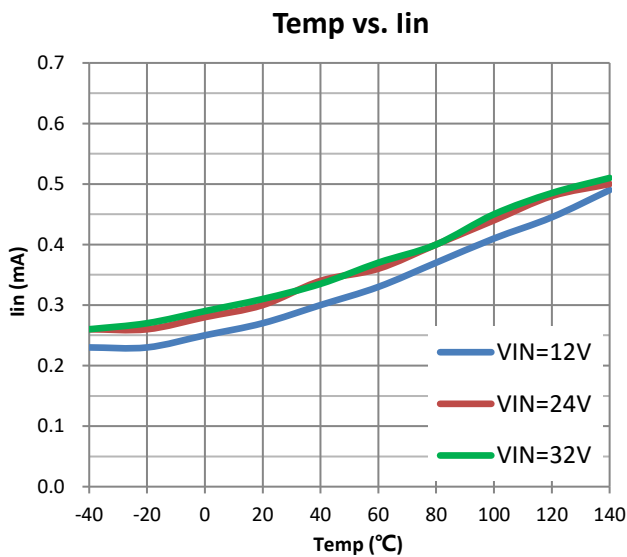
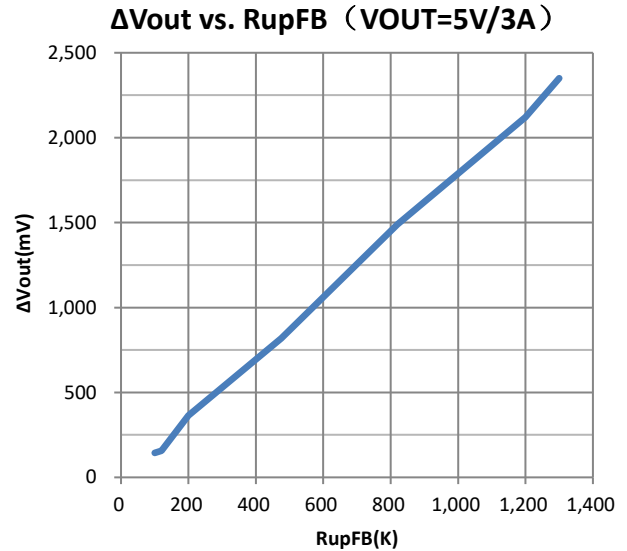
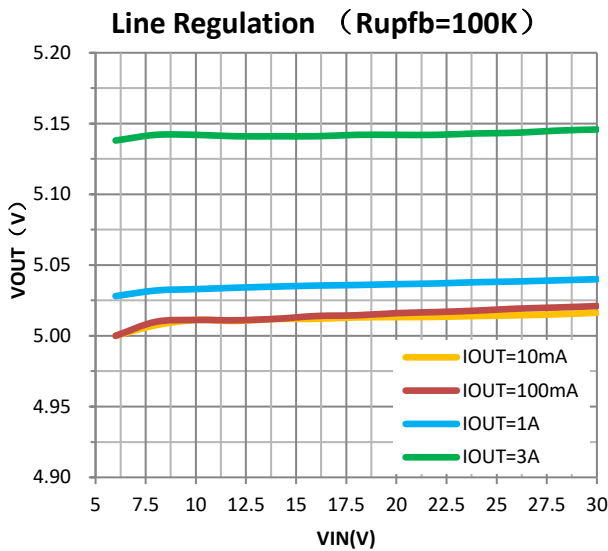
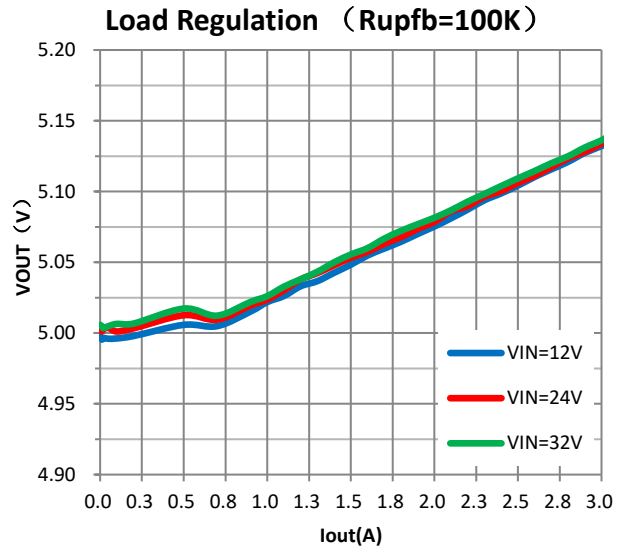
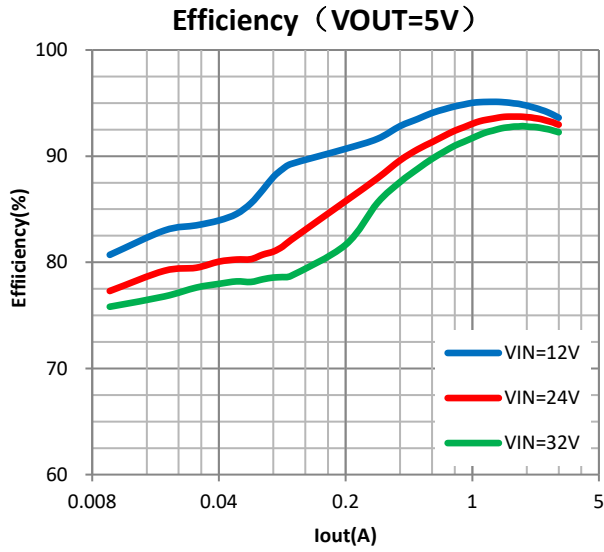

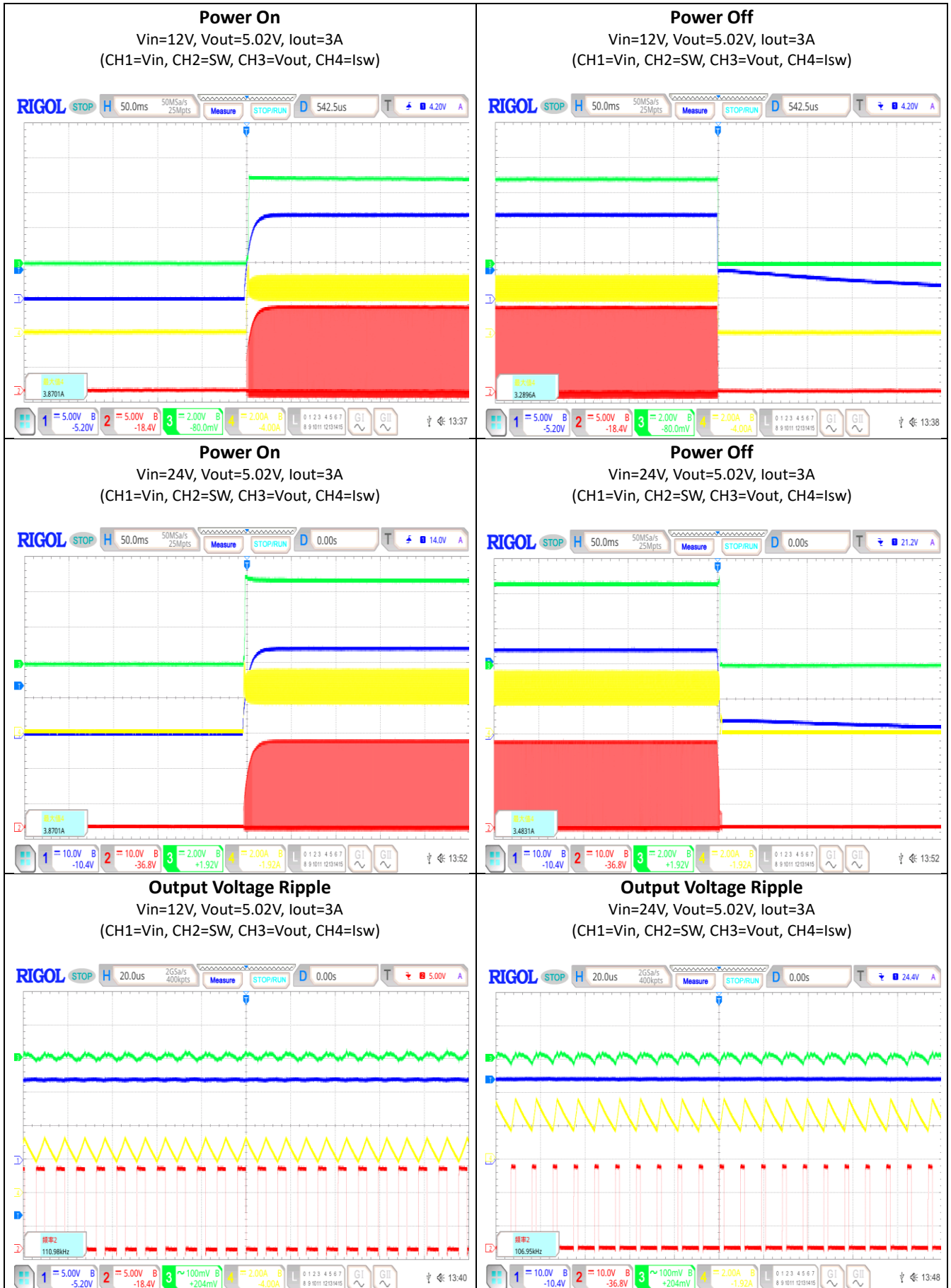

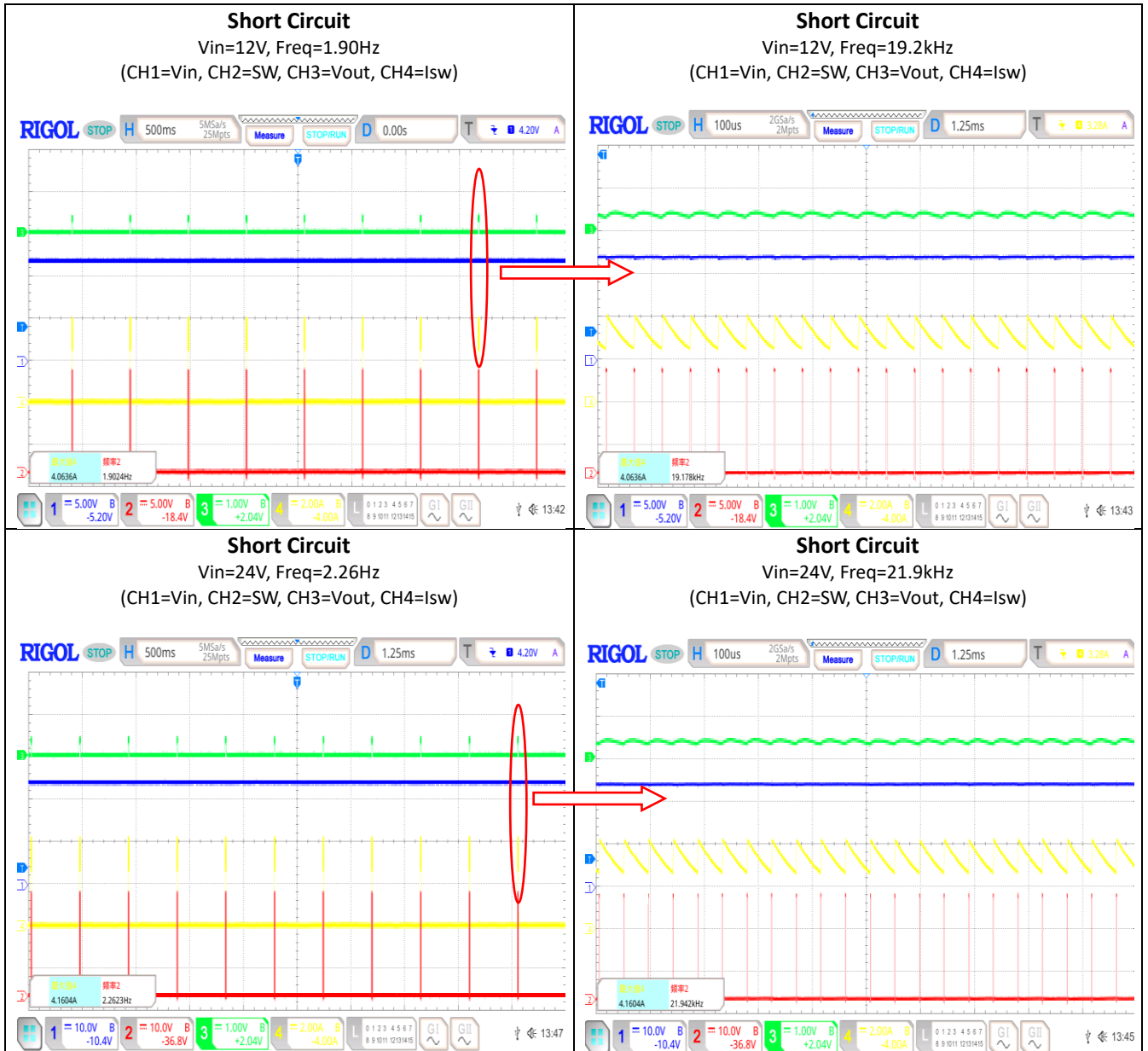

Operation

The NDP14301KC is a high efficiency, monolithic, synchronous step-down DC/DC converter utilizing a constant frequency, average current mode control architecture. Average current mode control enables fast and precise control of the output current. It operates through a wide VIN range and regulates with low quiescent current. An error amplifier compares the output voltage with a internal reference voltage of 1.0V and adjusts the peak inductor current accordingly. overvoltage and undervoltage comparators will turn off the regulator.

Main Control Loop

During normal operation, the internal top power switch (P-channel MOSFET) is turned on at the beginning of each clock cycle, causing the inductor current to increase. The sensed inductor current is then delivered to the average current amplifier, whose output is compared with a saw-tooth ramp. When the voltage exceeds the v duty voltage, the PWM comparator trips and turns off the top power MOSFET. After the top power MOSFET turns off, the synchronous power switch (N-channel MOSFET) turns on, causing the inductor current to decrease. The bottom switch stays on until the beginning of the next clock cycle, unless the reverse current limit is reached and the reverse current comparator trips. In closed-loop operation, the average current amplifier creates an average current loop that forces the average sensed current signal to be equal to the internal ITH voltage. Note that the DC gain and compensation of this average current loop is automatically adjusted to maintain an optimum

current-loop response. The error amplifier adjusts the ITH voltage by comparing the divided-down output voltage (VFB) with a 1.0V reference voltage. If the load current changes, the error amplifier adjusts the average inductor current as needed to keep the output voltage in regulation.

Low Current operation

The discontinuous-conduction modes (DCMs) are available to control the operation of the NDP14301KC at low currents. Burst Mode operation automatically switch from continuous operation to the Burst Mode operation when the load current is low

VIN Overvoltage Protections

In order to protect the internal power MOSFET devices against transient voltage spikes, the NDP14301KC constantly monitors the VIN pin for an overvoltage condition. When VIN rises above 38V, the regulator suspends operation by shutting off both power MOSFETs. Once VIN drops below 37V, the regulator immediately resumes normal operation. The regulator executes its soft-start function when exiting an overvoltage condition.

Constant Voltage Output

NDP14301KC presets the VFB voltage to 1V. The Output can be set by extra resistance.

$$V_{OUT} = V_{FB} * \frac{R_{FB_TOP} + R_{FB_LOW}}{R_{FB_LOW}}$$

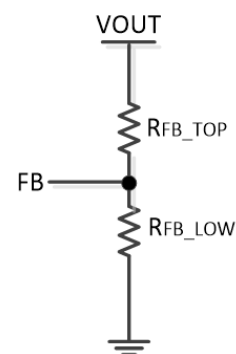

Cable Drop Compensation

Due to the resistive of charger's output Cable, The NDP14301KC built in a simple user programmable cable voltage drop compensation using the impedance at the FB pin. Choose the proper resistance values for charger's output cable as show in table 1:

R_{up} is the upper resistor the resistors divider net

R_{low} is the lower resistor the resistors divider net

$R_{FB(UPER)}$ (K)	R_{low} (K)	Cable Drop compensation (mV)
100	25	148
200	50	240
300	75	470
475	120	950
820	200	1670
1200	300	2200

table 1

Applications Information

Input Capacitor (CIN) Selection

The input capacitance CIN is needed to filter the square wave current at the drain of the top power MOSFET. To prevent large voltage transients from occurring, a low ESR input capacitor sized for the maximum RMS current should be used. The maximum RMS current is given by:

$$I_{RMS} \cong I_{OUT(MAX)} \frac{V_{OUT}}{V_{IN}} \sqrt{\frac{V_{IN}}{V_{OUT}} - 1}$$

This formula has a maximum at $V_{IN} = 2V_{OUT}$, where: $I_{RMS} \cong I_{OUT}/2$

This simple worst-case condition is commonly used for design because even significant deviations do not offer much relief. Note that ripple current ratings from capacitor manufacturers are often based on only 2000

hours of life which makes it advisable to further derate the capacitor, or choose a capacitor rated at a higher temperature than required. Several capacitors may also be paralleled to meet size or height requirements in the design. For low input voltage applications, sufficient bulk input capacitance is needed to minimize transient effects during output load changes.

Output Capacitor (COUT) Selection

The selection of COUT is determined by the effective series resistance (ESR) that is required to minimize voltage ripple and load step transients as well as the amount of bulk capacitance that is necessary to ensure that the control loop is stable. Loop stability can be checked by viewing the load transient response. The output ripple, ΔV_{OUT} , is determined by:

$$\Delta V_{OUT} < \Delta I_L \left(\frac{1}{8 \cdot f \cdot C_{OUT}} + ESR \right)$$

The output ripple is highest at maximum input voltage since ΔI_L increases with input voltage. Multiple capacitors placed in parallel may be needed to meet the ESR and RMS current handling requirements. Dry tantalum, special polymer, aluminum electrolytic, and ceramic capacitors are all available in surface mount packages. Special polymer capacitors are very low ESR but have lower capacitance density than other types. Tantalum capacitors have the highest capacitance density but it is important to only use types that have been surge tested for use in switching power supplies. Aluminum electrolytic capacitors have significantly higher ESR, but can be used in cost-sensitive applications provided that consideration is given to ripple current ratings and long-term reliability. Ceramic capacitors

have excellent low ESR characteristics and small footprints.

Inductor Selection

Given the desired input and output voltages, the inductor value and operating frequency determine the ripple current:

$$\Delta I_L = \frac{V_{OUT}}{F * L} \left(1 - \frac{V_{OUT}}{V_{IN(MAX)}} \right)$$

Lower ripple current reduces power losses in the inductor, ESR losses in the output capacitors and output voltage ripple. Highest efficiency operation is obtained at low frequency with small ripple current. However, achieving this requires a large inductor. There is a trade-off between component size, efficiency and operating frequency. A reasonable starting point is to choose a ripple current that is about 40% of IOUT(MAX). To guarantee that ripple current does not exceed a specified maximum, the inductance should be chosen according to:

$$L = \frac{V_{OUT}}{F * \Delta I_L(MAX)} \left(1 - \frac{V_{OUT}}{V_{IN(MAX)}} \right)$$

Once the value for L is known, the type of inductor must be selected. Actual core loss is independent of core size for a fixed inductor value, but is very dependent on the inductance selected. As the inductance or frequency increases, core losses decrease. Unfortunately, increased inductance requires more turns of wire and therefore copper losses will increase. Copper losses also increase as frequency increases. Ferrite designs have very low core losses and are preferred at high switching frequencies, so design goals can concentrate on copper loss and preventing saturation. Ferrite core material saturates “hard”, which means that inductance collapses abruptly when the peak design current is exceeded. This

results in an abrupt increase in inductor ripple current and consequent output voltage ripple. Do not allow the core to saturate!

Different core materials and shapes will change the size/current and price/current relationship of an inductor. Toroid or shielded pot cores in ferrite or permalloy materials are small and don't radiate much energy, but generally cost more than powdered iron core inductors with similar characteristics. The choice of which style inductor to use mainly depends on the price versus size requirements and any radiated field/EMI requirements. New designs for surface mount inductors are available from Coilcraft, Toko, Vishay, NEC/Tokin, TDK and Würth Elektronik.

Efficiency Considerations

The percent efficiency of a switching regulator is equal to the output power divided by the input power times 100%. It is often useful to analyze individual losses to determine what is limiting the efficiency and which change would produce the most improvement. Percent efficiency can be expressed as: % Efficiency = 100% – (Loss1 + Loss2 + ...) where Loss1, Loss2, etc. are the individual losses as a percentage of input power. Although all dissipative elements in the circuit produce losses, three main sources usually account for most of the losses in NDP14301KC circuits: 1) I²R losses, 2) switching and biasing losses, 3) other losses.

Thermal Conditions

In a majority of applications, the NDP14301KC does not dissipate much heat due to its high efficiency and low thermal resistance. However, in applications where the NDP14301KC is running at high ambient temperature, high VIN,

and maximum output current load, the heat dissipated may exceed the maximum junction temperature of the part.

If the junction temperature reaches approximately 165°C, both power switches will be turned off until the temperature drops about 30°C cooler avoid the NDP14301KC from exceeding the maximum junction temperature, the user will need to do some thermal analysis.

The goal of the thermal analysis is to determine whether the power dissipated exceeds the maximum junction temperature of the part. If the application calls for a higher ambient temperature and/or higher switching frequency, care should be taken to reduce the temperature rise of the part by using a heat sink or forced air flow.

Typical Applications

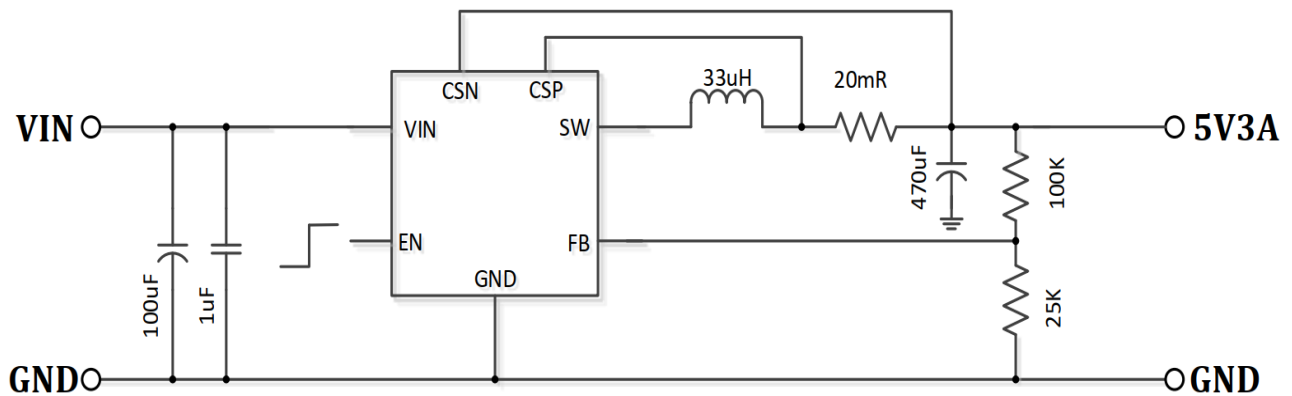

Package Description

8-Lead Standard Small Outline Package [SOP-8]

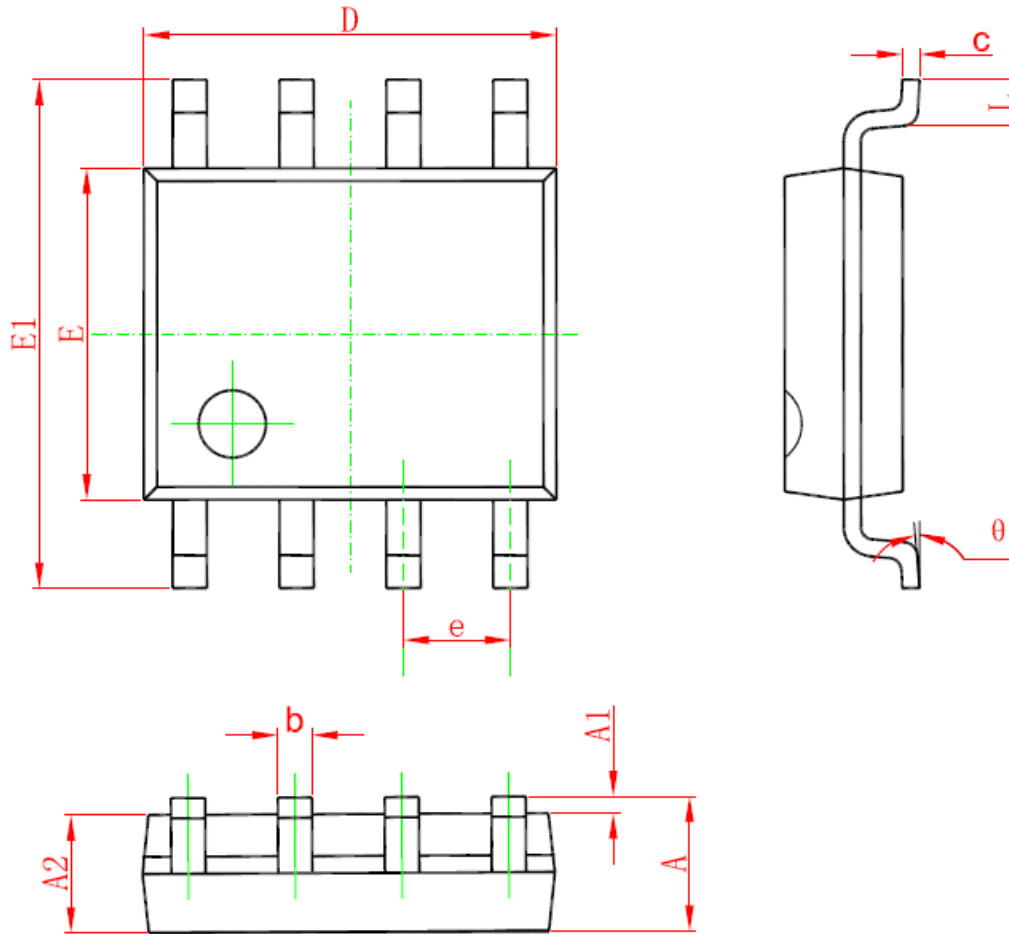

Symbol	Dimensions In Millimeters		Dimensions In Inches	
	Min	Max	Min	Max
A	1.350	1.750	0.053	0.069
A1	0.050	0.250	0.002	0.010
A2	1.250	1.650	0.049	0.065
b	0.310	0.510	0.012	0.020
c	0.170	0.250	0.006	0.010
D	4.700	5.150	0.185	0.203
E	3.800	4.000	0.15	0.157
E1	5.800	6.200	0.228	0.244
e	1.270 (BSC)		0.05 (BSC)	
L	0.400	1.270	0.016	0.050
θ	0°	8°	0°	8°