

400mA Low Dropout Voltage Regulator with Shutdown

FEATURES

- Output 3.3V, 5.0V at 400mA Output
- Very Low Quiescent Current, 100 μ A
- Low Dropout Voltage, 420mV at 400mA
- Extremely Tight Load and Line Regulation
- Very Low Temperature Coefficient
- Current & Thermal Limiting
- Error Flag Warns Of Output Dropout
- Logic-Controlled Electronic Shutdown
- Output Programmable From 1.24V to 20V (for SO-8)

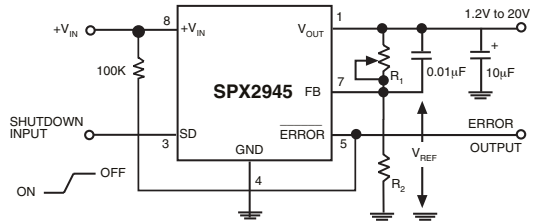

Adjustable Regulator

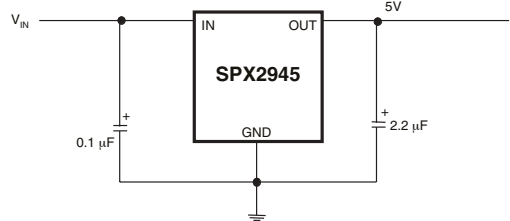

5V Regulator Circuit

Now Available in Lead Free Packaging

DESCRIPTION

The SPX2945 is a low power voltage regulator. This device is an excellent choice for use in battery-powered applications such as cordless telephones, radio control systems, and portable computers. The SPX2945 features very low quiescent current (100 μ A Typ.) and very low dropout voltage. This includes a tight initial tolerance of 1% max and very low output temperature coefficient, making the SPX2945 useful as a low-power voltage reference.

The error flag output feature is used as power-on reset for warning of a low output voltage, due to a falling voltage input of batteries. Another feature is the logic-compatible shutdown input which enables the regulator to be switched on and off. The SPX2945 is offered in 3-pin TO-220 package, SO-8 (same pin out as SPX2951), SOT-223, surface mount 3-Pin TO-252, 3-Pin TO-263 packages and 5-Pin TO-263.

The regulator output voltage (of the 8-pin SO-8) may be pin-strapped for a 3.3V and 5.0V or programmed from 1.24V to 20V with an external pair of resistors. Look for SPX2951 for 150mA and SPX2954 for 250mA applications.

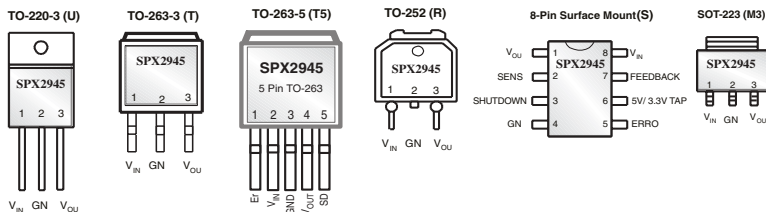

ABSOLUTE MAXIMUM RATINGS

Power Dissipation Internally Limited
 Lead Temp. (Soldering, 5 Seconds) 260°C
 Storage Temperature Range -65°C to +150°C
 Operating Junction Temperature Range -40°C to +125°C
 Input Supply Voltage -20V to +26V

Feedback Input Voltage -1.5V to +26V
 Shutdown Input Voltage -0.3V to +26V
 Error Comparator Output -0.3V to +26V
 ESD Rating 2kV Min

ELECTRICAL CHARACTERISTICS

Electrical characteristics at $V_{IN} = V_O + 1V$, $I_O = 1mA$, $C_{OUT} = 2.2\mu F$, $T_A = 25^\circ C$, unless otherwise specified. The ♦ denotes the specifications which apply over full operating temperature range -40°C to +85°C, unless noted.

PARAMETER	CONDITIONS (Note 2)	MIN	TYP	MAX		UNITS		
3.3V Version								
Output Voltage	$1mA \leq I_L \leq 400mA$	3.267	3.3	3.333		V		
		3.217	3.3	3.382	♦			
5.0V Version								
Output Voltage	$1mA \leq I_L \leq 400mA$	4.950	5.0	5.050		V		
		4.880	5.0	5.120	♦			
All Voltage Options								
Output Voltage Temperature Coefficient	(Note1)	20		100	♦	ppm/°C		
Line Regulation (Note 3)	$6V \leq V_{IN} \leq 20V$ (Note 4)		1.5	20	♦	mV		
Load Regulation (Note 3)	$I_L = 1$ to 400mA		6	20	♦	mV		
				30				
Dropout Voltage (Note5)	$I_L = 1mA$ $I_L = 400mA$		60	100	♦	mV		
				150				
			360	450			700	
Ground Current	$I_L = 1mA$		100	200	♦	μA		
				300				
	$I_L = 150mA$		2	4			♦	mA
				6				
	$I_L = 300mA$		4	8				
			12					
	$I_L = 400mA$		8	15	♦			
				25	♦			
Current Limit	$V_{OUT} = 0$		330	800	♦	mA		
Thermal Regulation			0.05	0.2		%/W		
Output Noise, 10Hz to 100kHz, $I_L = 100mA$	$C_L = 2.2\mu F$ $C_L = 33\mu F$		400			μV_{RMS}		
			260					
PSRR at 100KHz $I_L = 100mA$	$C_L = 10\mu F$		31			dB		
Adjustable 8 Pin Version only								
Reference Voltage		1.210	1.235	1.260		V		
Reference Voltage	Over Temperature	1.185		1.285		V		
Feedback Pin Bias Current			20	40	♦	nA		
				60				
Reference Voltage Temp. Coefficient			20			ppm/°C		

ELECTRICAL CHARACTERISTICS: Continued

Electrical characteristics at $V_{IN} = V_O + 1V$, $I_O = 1mA$, $C_{OUT} = 2.2\mu F$, $T_A = 25^\circ C$, unless otherwise specified. ♦ applies over the full operating temperature range.

PARAMETER	CONDITIONS (Note 2)	MIN	TYP	MAX	♦	UNITS
Feedback Pin Bias Current Temperature Coefficient			0.1			nA/°C
Output Leakage Current	$V_{OH}=20V$		0.01	1 2	♦	μA
Output Low Voltage	$V_{IN}=4.5V$ $I_{OL}=400\mu A$		150	250 400	♦	mV
Upper Threshold Voltage	(Note 6)	40 25	60			mV
Lower Threshold Voltage	(Note 6)		75	95 140	♦	mV
Hysteresis	(Note 6)		15			mV
Input Logic Voltage	Low (Regulator ON) High (Regulator OFF)		1.3	0.7 2.0	♦ ♦	V
Shutdown Pin Input Current	$V_S=2.4V$ $V_S=26V$		30 450	50 100 600 750	♦ ♦ ♦	μA
Regulator Output Current in Shutdown	(Note 7)	10 20	3		♦	μA

Note 1: Output or reference voltage temperature coefficients defined as the worst case voltage change divided by the total temperature range.

Note 2: Unless otherwise specified all limits are guaranteed for $T_J = 25^\circ C$, $V_{IN} = 6V$, $I_L = 1mA$ and $C_L = 2.2\mu F$. Additional conditions for the 8-pin versions are feedback tied to 5V/3.3V tap and output tied to output sense ($V_{OUT} = 5V$) and $V_{SHUTDOWN} \leq 0.8V$.

Note 3: Regulation is measured at constant junction temperature, using pulse testing with a low duty cycle. Changes in output voltage due to heating effects are covered under the specification for thermal regulation.

Note 4: Line regulation for the SPX2945 is tested at $150^\circ C$ for $I_L = 1mA$. For $T_J = 125^\circ C$, line regulation is guaranteed by design.

Note 5: Dropout voltage is defined as the input to output differential at which the output voltage drops 100 mV below its nominal value measured at 1V differential at very low values of programmed output voltage, the minimum input supply voltage of 2V (2.3V over temperature) must be taken into account.

Note 6: Comparator thresholds are expressed in terms of a voltage differential at the feedback terminal below the nominal reference voltage measured at 6V input. To express these thresholds in terms of output voltage change, multiply by the error amplifier gain $= V_{OUT}/V_{REF} = (R1 + R2)/R2$. For example, at a programmed output voltage of 5V, the Error output is guaranteed to go low when the output drops by $95mV \times 5V/1.235 = 384mV$. Thresholds remain constant as a percent of V_{OUT} as V_{OUT} is varied, with the dropout warning occurring at typically 5% below nominal, 7.5% guaranteed.

Note 7: $V_{SHUTDOWN} \geq 2V$, $V_{IN} \leq 26V$, $V_{OUT} = 0$, Feedback pin tied to 5V/3.3V Tap.

Error Detection Comparator Output

The Comparator produces a logic low output whenever the SPX2945 output falls out of regulation by more than around 5%. This is around 60mV offset divided by the 1.235 reference voltage. This trip level remains 5% below normal regardless of the programmed output voltage of the regulator. Figure 1 shows the timing diagram depicting the ERROR signal and the regulator output voltage as the SPX2945 input is ramped up and down. The ERROR signal becomes low at around 1.3V input, and goes high around 5V input (input voltage at which $V_{OUT} = 4.75$). Since the SPX2945's dropout voltage is load dependent, the input voltage trip point (around 5V) will vary with the load current. The output voltage trip point (approx. 4.75V) does not vary with load.

The error comparator has an open-collector output, which requires an external pull-up resistor. Depending on the system requirements the resistor may be returned to 5V output or other supply voltage. In determining the value of this resistor, note that the output is rated to sink 400 μ A; this value adds to battery drain in a low battery condition. Suggested values range from 100K to 1M Ω . If the output is unused this resistor is not required.

Programming the Output Voltage of SPX2945

The SPX2945 may be pin-strapped for 5V or 3.3V using its internal voltage divider by tying Pin 1 (output) to Pin 2 (sense) and Pin 7 (feedback) to Pin 6 (5V/3.3V Tap).

Also, it may be programmed for any output voltage between its 1.235V reference and its 20V maximum rating. As seen in Figure 2, an external pair of resistors is required.

Refer to the below equation for the programming of the output voltage::

$$V_{OUT} = V_{REF} \times (1 + R_1/R_2) + I_{FB}R_1$$

The V_{REF} is 1.235 and I_{FB} is the feedback bias current, nominally -20nA. The minimum recommended load current of 1 μ A forces an upper limit of 1.2 M Ω on value of R_2 . If no load is presented the I_{FB} produces an error of typically

2% in V_{OUT} , which may be eliminated at room temperature by trimming R_1 . To improve the accuracy choose the value of $R_2 = 100k$; this reduces the error by 0.17% and increases the resistor program current by 12 μ A. Since the SPX2945 typically draws 60 μ A at no load with Pin 2 open-circuited this is a small price to pay.

Reducing Output Noise

It may be an advantage to reduce the AC noise present at the output. One way is to reduce the regulator bandwidth by increasing the size of the output capacitor. This is the only way that noise can be reduced on the 3 lead SPX2945 but is relatively inefficient, as increasing the capacitor from 1 μ F to 220 μ F only decreases the noise from 430 μ V to 160 μ V Vrms for a 100kHz bandwidth at 5V output. Noise could also be reduced fourfold by a bypass capacitor across R_1 , since it reduces the high frequency gain from 4 to unity. Pick

$$C_{BYPASS} \cong 1 / 2\pi R_1 \times 200 \text{ Hz}$$

or choose 0.01 μ F. When doing this, the output capacitor must be increased to 3.3 μ F to maintain stability. These changes reduce the output noise from 430 μ V to 100 μ V Vrms for a 100kHz bandwidth at 5V output. With the bypass capacitor added, noise no longer scales with output voltage so that improvements are more dramatic at higher output voltages.

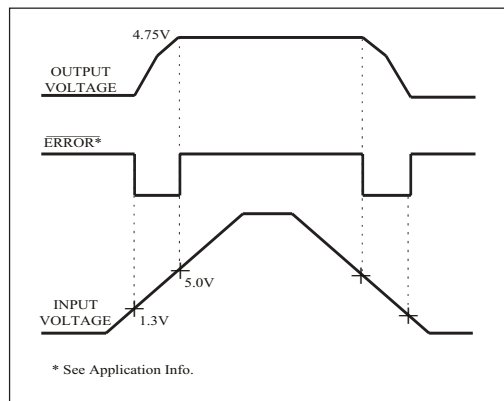
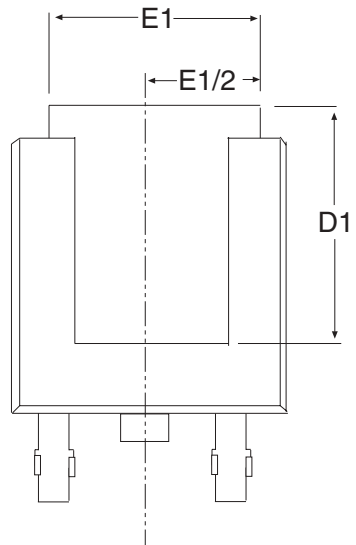
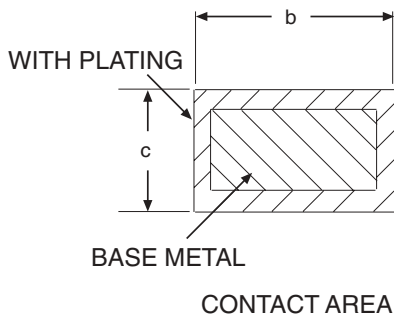
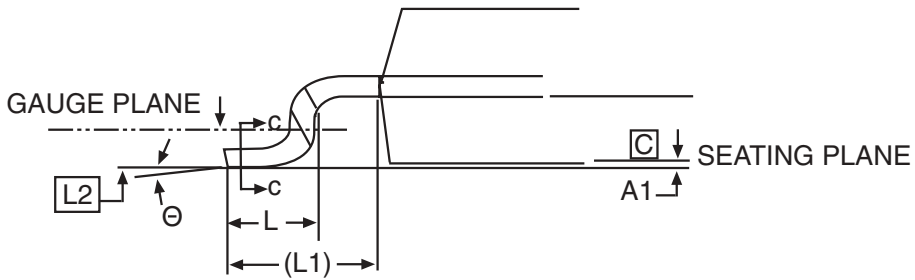
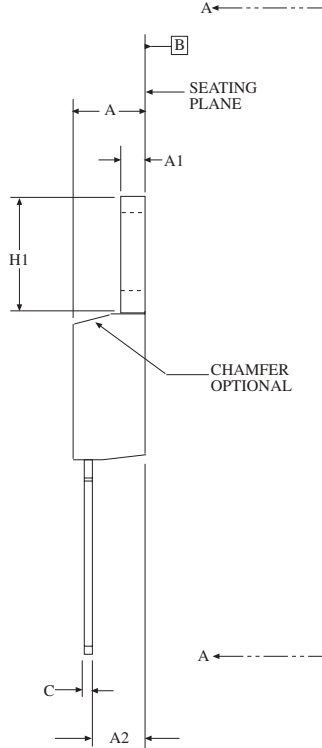
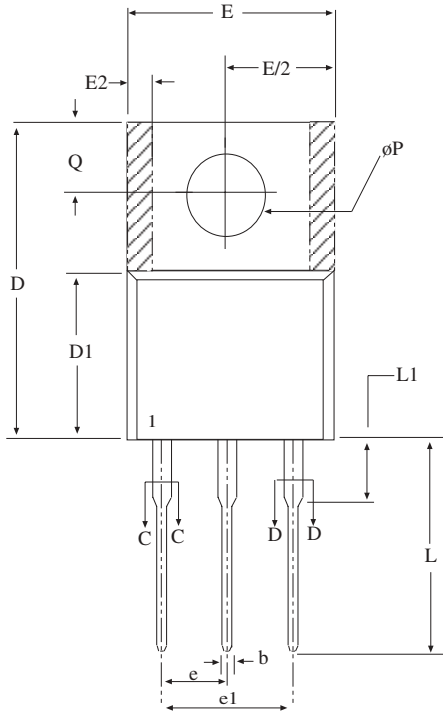

Figure 1. ERROR Output Timing



3 PIN TO-252 JEDEC TO-252 (AA) Variation	Dimensions in inches		
	MIN	NOM	MAX
A1	-	-	.005
c	.018	-	.024
D1	.205	-	-
E1	.170	-	-
H	.370	-	.410
L	.055	.060	.070
L1	.108 REF		
L2	.020 BSC		

3 PIN TO-252



Dimensions in (mm)	3 PIN TO-220 JEDEC TO-220 (AB) Variation		
	MIN	NOM	MAX
A	.140	-	.190
A1	.020	-	.055
A2	.080	-	.115
b	.015	.027	.040
b2	.045	-	.070
c	.014	-	.024
D	.560	-	.650
D1	.330	-	.355
D2	.480	-	.507
E	.380	-	.420
E1	.270	-	.350
E2	-	-	.030
e	.100 BSC		
e1	.200 BSC		
H1	.230	-	.270
L1	-	-	.250
L2	-	-	-
ΔP	.139	-	.161
Q	.100	-	.135

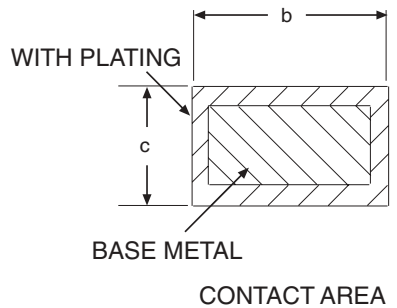

3 PIN TO-220

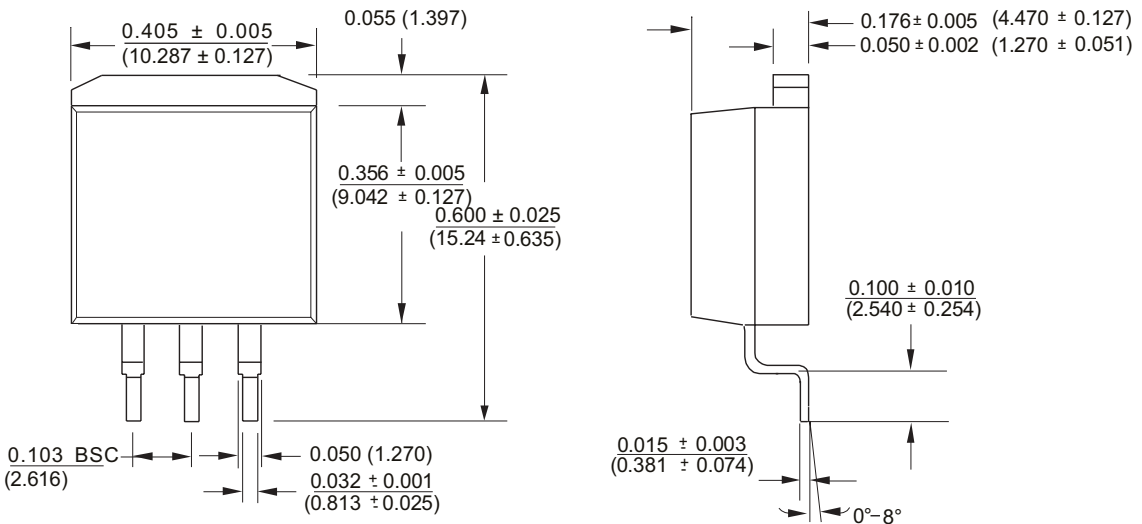
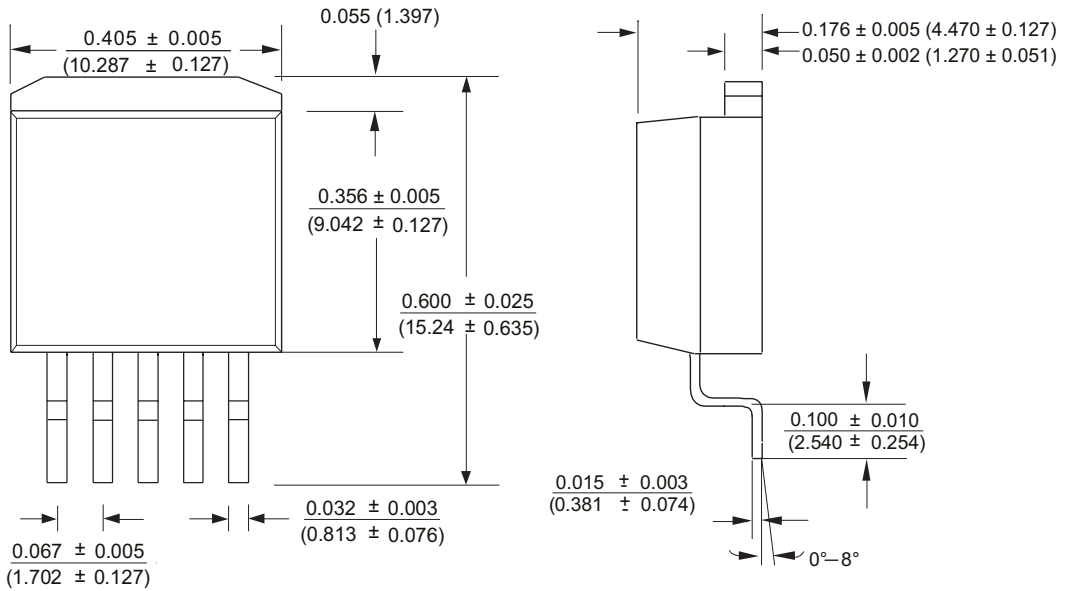

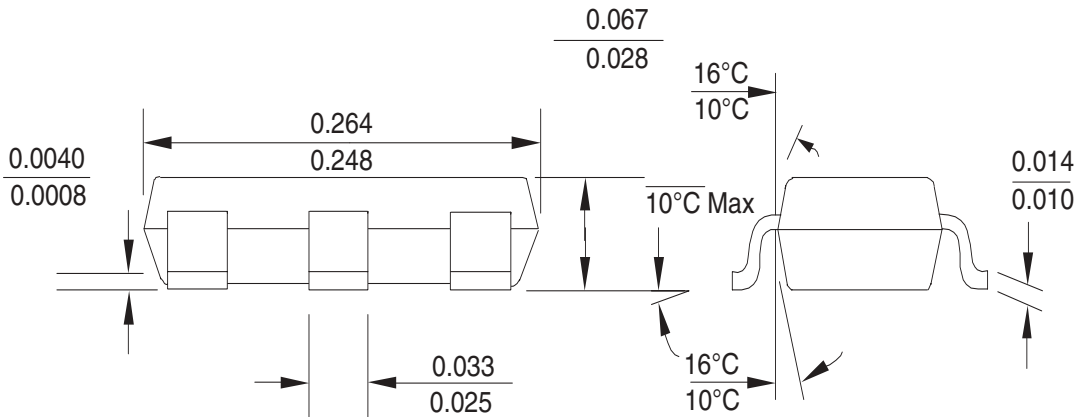
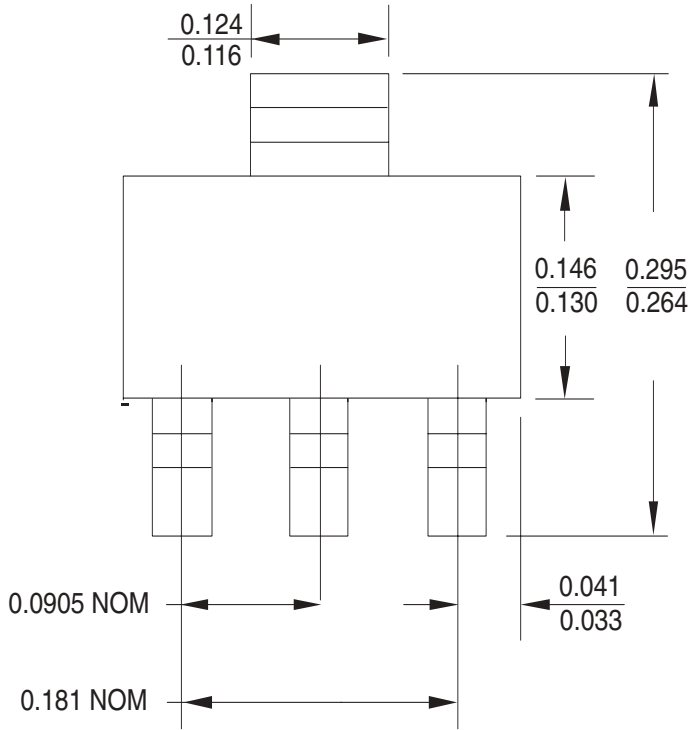

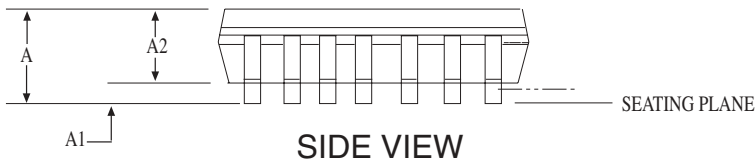
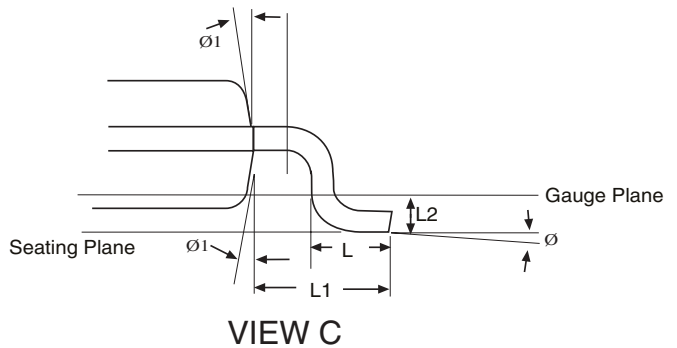
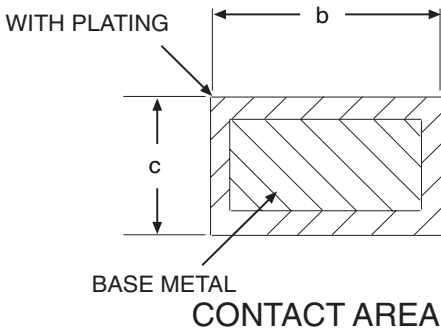
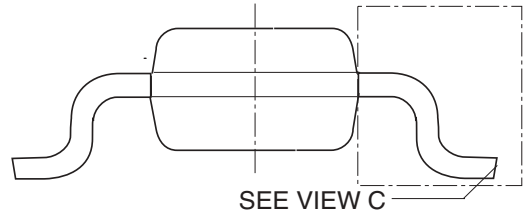
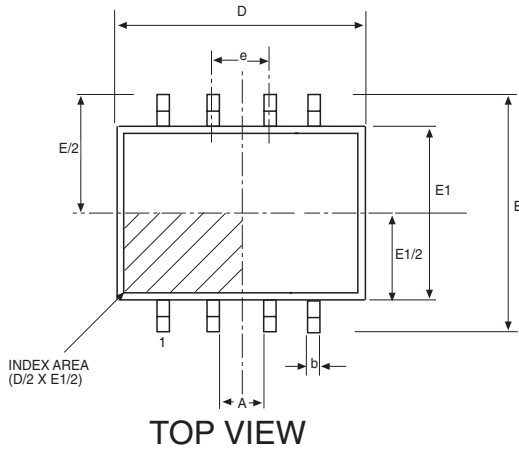

DIMENSIONS Minimum/Maximum (mm)	8 Pin NSOIC (JEDEC MS-012, AA - VARIATION)		
COMMON HEIGHT DIMENSION			
SYMBOL	MIN	NOM	MAX
A	1.35	-	1.75
A1	0.10	-	0.25
A2	1.25	-	1.65
b	0.31	-	0.51
c	0.17	-	0.25
D	4.90 BSC		
E	6.00 BSC		
E1	3.90 BSC		
e	1.27 BSC		
L	0.40	-	1.27
L1	1.04 REF		
L2	0.25 BSC		
Ø	0°	-	8°
Ø1	5°	-	15°

8 PIN NSOIC

ORDERING INFORMATION

Ordering No.	Accuracy	Output Voltage	Packages
SPX2945M3-3.3	1%	3.3V	3-Pin SOT-223
SPX2945M3-3.3/TR	1%	3.3V	3-Pin SOT-223
SPX2945M3-5.0	1%	5.0V	3-Pin SOT-223
SPX2945M3-5.0/TR	1%	5.0V	3-Pin SOT-223
SPX2945S-3.3	1%	3.3V	8-Pin NSOIC
SPX2945S-3.3/TR	1%	3.3V	8-Pin NSOIC
SPX2945S-5.0	1%	5.0V	8-Pin NSOIC
SPX2945S-5.0/TR	1%	5.0V	8-Pin NSOIC
SPX2945R-3.3	1%	3.3V	3-Pin TO-252
SPX2945R-3.3/TR	1%	3.3V	3-Pin TO-252
SPX2945R-5.0	1%	5.0V	3-Pin TO-252
SPX2945R-5.0/TR	1%	5.0V	3-Pin TO-252
SPX2945T-3.3	1%	3.3V	3-Pin TO-263
SPX2945T-3.3/TR	1%	3.3V	3-Pin TO-263
SPX2945T-5.0	1%	5.0V	3-Pin TO-263
SPX2945T-5.0/TR	1%	5.0V	3-Pin TO-263
SPX2945T5-3.3	1%	3.3V	5-Pin TO-263
SPX2945T5-3.3/TR	1%	3.3V	5-Pin TO-263
SPX2945T5-5.0	1%	5.0V	5-Pin TO-263
SPX2945T5-5.0/TR	1%	5.0V	5-Pin TO-263
SPX2945U-3.3	1%	3.3V	3-Pin TO-220
SPX2945U-5.0	1%	5.0V	3-Pin TO-220

Available in lead free packaging. To order add "-L" suffix to part number.

Example: SPX2954S-5.0/TR = standard; SPX2954S-L-5.0/TR = lead free

/TR = Tape and Reel

Pack quantity is 500 for TO-263, 2,000 for TO-252, and 2,500 for SOT223 or NSOIC.



ANALOG EXCELLENCE

Sipex Corporation

**Headquarters and
Sales Office**

233 South Hillview Drive
Milpitas, CA 95035
TEL: (408) 934-7500
FAX: (408) 935-7600