

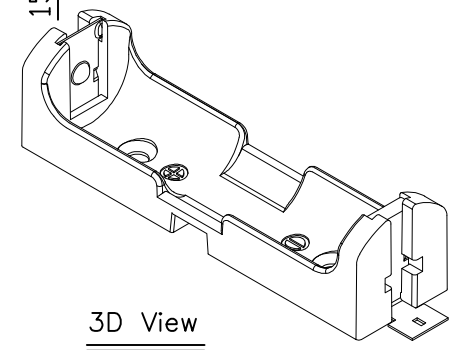

REV.	ECN NO.	REVISED	DATE

NOTE:

- MATERIAL:
 - HOUSING: NYLON RESIN BLACK
 - SPRING: C5191 (SURFACE PLATING: Au1u")
SEE ORDERING INFORMATION
- ELECTRIC:
 - DIELECTRIC VOLTAGE: 270V AC ONE SEC LEVEL
 - OPERATING TEMPERATURE: -10° C ~ +100° C

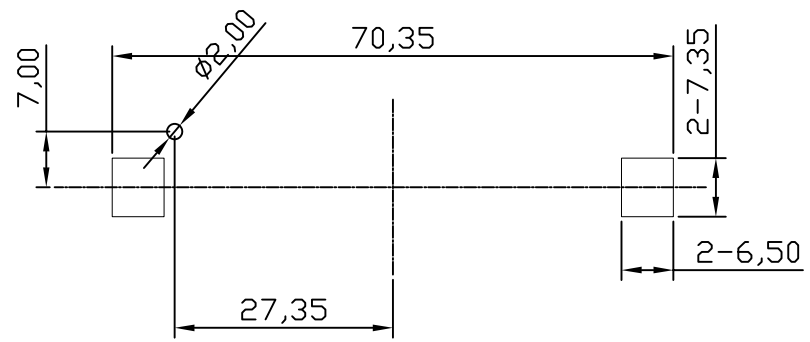
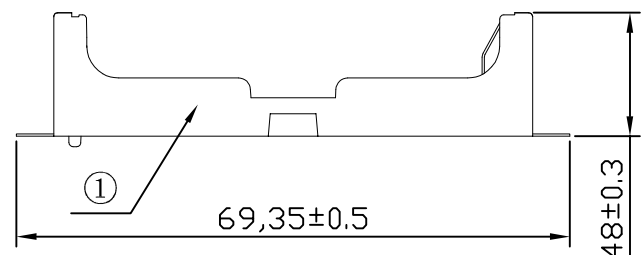
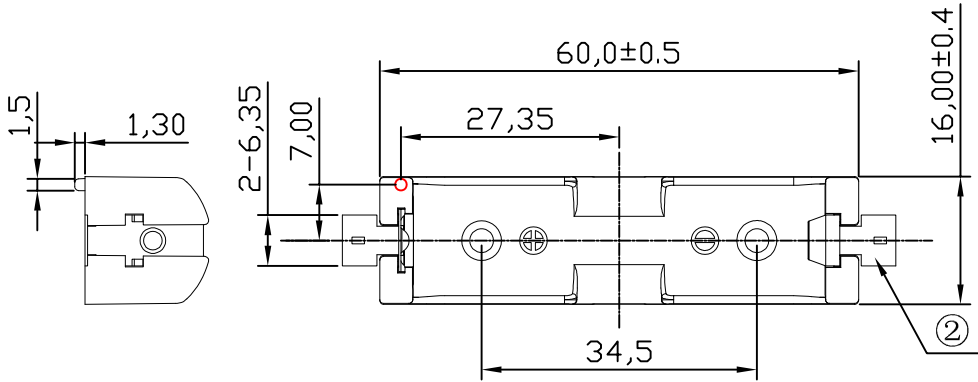

3D View

ORDERING INFORMATION

BH-AA-B*026**

电池盒

电池型号

SMT 180° TYPE

PLATING:
A-Au1U"
J-Ni100U"~120U"
K-Sn100U"~120U"

MATERIAL:
1A-PP BLACK
1B-PA66 BLACK
2A-PPA BROWN
2B-PPA BLACK
3A-PPS BROWN
3B-PPS BLACK
4A-LCP WHITE
4B-LCP BLACK
5B-NYLON RESIN BLACK



MOUNTING DETAIL

UNLESS OTHERWISE SPECIFIED TOLERANCES		MYOUNG 美阳 www.meiyangdz.com	
DECIMALS: X :±0.30 X.X :±0.25 X.XX :±0.20 X.XXX :±0.10	ANGLES: X :±1° X.X :±0.5°	DSND YangFeng	DATE 2022-01-15
WEIGHT: SHEET 1 OF 1		CHKD ZhouRuicai	DATE 2022-01-15
		APVD XueShunyong	DATE 2022-01-15
TITLE: 电池盒BH-AA-1J Au SMT		PART NO.: BH-AA-B5BA026	
UNIT: mm		SCALE:	VIEW:
REV.: A/1		SIZE: A4	OBJECT: MY
DRAW NO.:WD-CP-0188			

②	CONTACT	2	C5191, 0.35MM	Au-Plating
①	HOUSING	1	NYLON Resin	BLACK
NO.	PART NAME	Q'TY	MATERIAL	PLATING & COLOR