

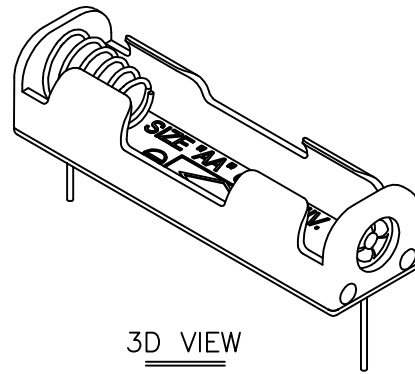

REV.	ECN NO.	REVISED	DATE

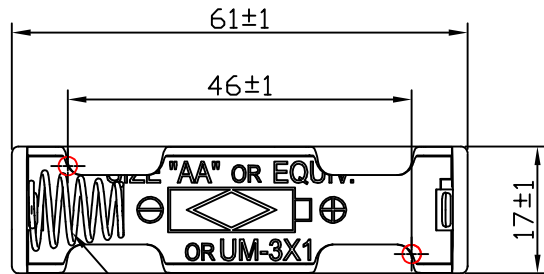

3D VIEW

NOTE:

1.MATERIAL:

- a.HOUSING:PP RESIN BLACK
- b.CONTACT:BRASS
(SURFACE PLATING: NI-PLATING)
SEE ORDERING INFORMATION
- c.OPERATING TEMPERATURE: -10° C~ +80° C

ORDERING INFORMATION

BH-AA-A1AJ025

电池盒

电池型号

DIP 90° TYPE

PLATING:
A-Au1U"
J-Ni-PLATING
K-Sn-PLATING

MATERIAL:
1A-PP BLACK
1B-PA66 BLACK
2A-PPA BROWN
2B-PPA BLACK
3A-PPS BROWN
3B-PPS BLACK
4A-LCP WHITE
4B-LCP BLACK
5A-PA9T BLACK

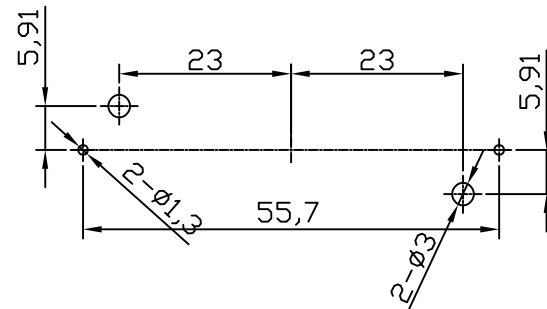
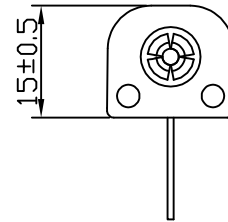
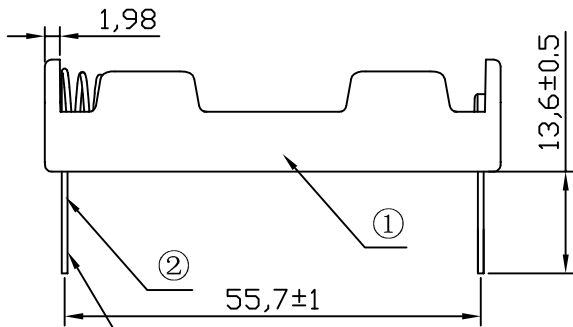

MOYOTING PAD LAYOUT



3	SPRING	1	65C SPRING WIRE, ϕ 0.65MM	Ni-Plating
2	TERMINAL	2	BRASS, ϕ 0.8MM	Ni-Plating
1	HOUSING	1	PP Resin	BLACK
NO.	PART NAME	Q'TY	MATERIAL	PLATING & COLOR

UNLESS OTHERWISE SPECIFIED TOLERANCES		MYOUNG 美阳 www.meiyangdz.com	
DECIMALS: X :±0.30 X.X :±0.25 X.XX :±0.20 X.XXX :±0.10	ANGLES: X :±1° X.X :±0.5°	DSND YangFeng	DATE 2021-09-03
		CHKD ZhouRuicai	DATE 2021-09-03
		APVD XueShunyong	DATE 2021-09-03
WEIGHT:		SCALE:	VIEW:
SHEET 1 OF 1		SIZE: A4	REV.: A/1
		UNIT: mm	OBJECT: MY
		DATE	TITLE: 电池盒BH-AA-1J 加长 长脚DIP(14505)
		DATE	PART NO.: BH-AA-A1AJ025
		DATE	DRAW NO.:WD-CP-0167