



8Gb WT M-die DDR4 SDRAM Datasheet

ChangXin Memory Technologies, Inc.

Preliminary Ver. 0.4.1

Aug. 11, 2020



DISCLAIMER

The information presented in this document is for reference purposes only and may contain inaccuracies, omissions and errors. The information contained herein is subject to change or rendered obsolete without notice, including but not limited to product and roadmap changes, component changes, new model and/or product releases, firmware upgrades, or the like. This document supersedes and replaces all information supplied prior to the publication hereof. Any information set forth in this document shall not be relied on if the product described therein is obtained from any unauthorized distributor or other source not authorized by ChangXin Memory Technologies, Inc. (hereinafter referred to as "CXMT").

CXMT assumes no obligation to update, correct or revise this information. CXMT reserves the right to update, correct or revise this information without notice; in addition, CXMT has no obligation to notify any party of such updates, corrections and revisions.

This document and all information discussed herein remain the sole and exclusive property of CXMT. No license of any patent, copyright, mask work, trademark or any other intellectual property right is granted by one party to the other party under this document, by implication, estoppel or otherwise.

CXMT MAKES NO REPRESENTATIONS OR WARRANTIES WITH RESPECT TO THE CONTENTS HEREOF AND ASSUMES NO RESPONSIBILITY FOR ANY INACCURACIES, ERRORS OR OMISSIONS THAT MAY APPEAR IN THIS INFORMATION.

CXMT SPECIFICALLY DISCLAIMS ANY IMPLIED WARRANTIES OF MERCHANTABILITY OR FITNESS FOR ANY PARTICULAR PURPOSE. ALL SEMICONDUCTOR PRODUCTS HAVE INHERENT FAILURES RATES AND LIMITED USEFUL LIVES. CUSTOMERS ARE SOLELY RESPONSIBLE FOR DETERMINING WHETHER THE CXMT PRODUCT IS SUITABLE AND FIT FOR THE CUSTOMER'S SYSTEM, APPLICATION OR PRODUCT. IN NO EVENT SHALL CXMT BE LIABLE FOR ANY DIRECT, INDIRECT, SPECIAL OR OTHER CONSEQUENTIAL DAMAGES ARISING FROM THE USE OF ANY INFORMATION CONTAINED HEREIN, EVEN IF CXMT HAS EXPRESSLY ADVISED OF THE POSSIBILITY OF SUCH DAMAGES.

CONFIDENTIALITY OBLIGATION

This is to remind you of your continuing confidentiality obligation as set forth in the Non-Disclosure Agreement or the like, executed between you and CXMT prior to this meeting and/or visit CXMT and/or access any CXMT information by other means, directly or indirectly, even if it appears to be pseudonymous or anonymous. CXMT reserves the right to pursue any adequate legal action, including injunctive relief, in the case of any violations.



Revision History

Revision	Date	Description
Ver. 0.1	Sept. 9, 2019	First release
Ver. 0.2	Nov. 19, 2019	Update speed bin, part number decoding
Ver. 0.3	Feb. 24, 2020	Update ordering options and package dimension
Ver. 0.4	July 21, 2020	Update IDD specifications
Ver. 0.4.1	Aug. 11, 2020	Correct typo of "tRRD_L(1/2K)" on page 117, other typos on page 59, 76, 137

CXMT Privileged and Confidential



Contents

1. Core Specifications	7
1.1 Speed Bins.....	8
1.2 Key Features.....	8
1.3 Ordering Options	10
1.4 Part Number Decoding	10
1.5 Address Table	10
2. DDR4 SDRAM Package Specifications	11
2.1 DDR4 SDRAM Package Dimension	12
2.2 DDR4 SDRAM x8 Ballout Using MO-207.....	14
2.3 DDR4 SDRAM x16 Ballout Using MO-207.....	16
2.4 Pinout Description	17
3. Absolute Maximum Ratings	20
3.1 Absolute Maximum DC Ratings	20
3.2 Recommended DC Operating Conditions.....	21
3.3 DRAM Component Operating Temperature Range.....	22
4. AC & DC Input Measurement Levels	23
4.1 AC and DC Logic Input Levels for Single-ended Signals.....	24
4.2 AC and DC Input Measurement Levels: Vref Tolerances.....	25
4.3 AC and DC Logic Input Levels for Differential Signals.....	26
4.3.1 Differential Signal Definition.....	26
4.3.2 Differential Swing Requirements for Clock (CK_t - CK_c)	27
4.3.3 Single-ended Requirements for CK Differential Signals.....	28
4.3.4 Address, Command, and Control Overshoot and Undershoot Specifications	30
4.3.5 Clock Overshoot and Undershoot Specifications.....	31
4.3.6 Data, Strobe and Mask Overshoot and Undershoot Specifications	32
4.4 Slew Rate Definitions for Differential Input Signals.....	34



4.4.1	Slew Rate Definitions for Differential Input Signals (CK).....	34
4.4.2	Slew Rate Definition for Single-ended Input Signals (CMD/ADD).....	36
4.5	CK Differential Input Cross Point Voltage.....	37
4.6	CMOS Rail to Rail Input Levels for RESET_n	39
4.7	AC & DC Logic Input Levels for DQS Signals.....	40
4.7.1	Differential Signal Definition	40
4.7.2	Differential Swing Requirements for DQS (DQS_t - DQS_c).....	41
4.7.3	Peak Voltage Calculation Method.....	42
4.7.4	Differential Input Cross Point Voltage	43
4.7.5	Differential Input Slew Rate Definition.....	45
5.	AC & DC Output Measurement Levels.....	47
5.1	Output Driver DC Electrical Characteristics	48
5.1.1	Alert_n Output Drive Characteristic.....	50
5.1.2	Output Driver Characteristic of Connectivity Test (CT) Mode	51
5.2	Single-ended AC&DC Output Levels	53
5.3	Differential AC & DC Output Levels.....	53
5.4	Single-ended Output Slew Rate.....	54
5.5	Differential Output Slew Rate	55
5.6	Single-ended AC and DC Output Levels of Connectivity Test Mode	58
5.7	Test Load for Connectivity Test Mode Timing	59
6.	Speed Bin.....	60
6.1	DDR4-2666 Speed Bins and Operations	60
6.2	tREFI and tRFC Parameters.....	62
7.	IDD and IDDQ Specification Parameters and Test Conditions	63
7.1	IDD, IPP and IDDQ Measurement Conditions	64
7.1.1	IDD0, IDD0A and IPP0 Measurement-Loop Pattern.....	76
7.1.2	IDD1, IDD1A and IPP1 Measurement-Loop Pattern.....	78
7.1.3	IDD2N, IDD2NA, IDD2NL, IDD2NG, IDD2ND, IDD2N_par, IPP2,IDD3N, IDD3NA	



and IDD3P Measurement-Loop Pattern.....	80
7.1.4 IDD2NT and IDDQ2NT Measurement-Loop Pattern.....	82
7.1.5 IDD4R, IDDR4RA, IDD4RB and IDDQ4R Measurement-Loop Pattern ¹	84
7.1.6 IDD4W, IDD4WA, IDD4WB and IDD4W_par Measurement-Loop Pattern	86
7.1.7 IDD4WC Measurement-Loop Pattern	88
7.1.8 IDD5B Measurement-Loop Pattern	90
7.1.9 IDD7 Measurement-Loop Pattern.....	91
7.2 IDD Specifications	93
8. Input/Output Capacitance	97
9. Electrical Characteristics & AC Timing.....	103
9.1 Reference Load for AC Timing and Output Slew Rate.....	104
9.2 tREFI	105
9.3 Clock Specification	105
9.3.1 Definition for tCK(abs).....	105
9.3.2 Definition for tCK(avg).....	105
9.3.3 Definition for tCH(avg) and tCL(avg).....	106
9.3.4 Definition for tERR(nper).....	106
9.4 Timing Parameters by Speed Grade	107
9.4.1 Timing Parameters by Speed Bin for DDR4-1600 to 2400.....	107
9.4.2 Timing Parameters by Speed Bin for DDR4-2666 to 3200.....	115
9.5 Rounding Algorithms	129
9.6 The DQ Input Receiver Compliance Mask for Voltage and Timing.....	130
9.7 Command, Control, and Address Setup, Hold, and Derating	136

1. Core Specifications

This chapter is an index to help you quickly know the key features of DDR4 component and available product options.

- [Speed Bins on Page 8](#)
- [Key Features on Page 8](#)
- [Ordering Options on Page 10](#)
- [Part Number Decoding on Page 10](#)
- [Address Table on Page 10](#)

CXMT Privileged and Confidential

1.1 Speed Bins

Speed	DDR4-2666	Unit
CL-tRCD-tRP	18-18-18	
tCK	0.75	ns
CL	18	nCK
tRCD	13.5	ns
tRP	13.5	ns
tRAS	32	ns
tRC	45.5	ns

1.2 Key Features

- Power supply : VDD = VDDQ = 1.2V (1.14V to 1.26V); VPP = 2.5V (2.375V to 2.75V)
- JEDEC standard package: x8 78-ball FBGA; x16 96-ball FBGA
- Array Configuration : 16 banks (x8) 4 groups of 4 banks; 8 banks (x16) 2 groups of 4 banks
- 8n-bit prefetch architecture
- Burst Length (BL) : 8 and 4 with Burst Chop (BC)
- Programmable CAS Latency (CL)
- Programmable CAS Write Latency (CWL)
- Internal generated Vref for data inputs
- On-Die Termination (ODT) : support Nominal, Park and Dynamic ODT
- Differential clock and data strobe inputs (CK_t ,CK_c; DQS_t, DQS_c)
- Interface: 1.2V Pseudo Open Drain (POD) IO
- Per DRAM Addressability (PDA)
- Data Bus Inversion (DBI)
- Data Mask (DM) for write data
- Maximum Power Saving Mode (MPSM)
- Programmable Partial Array Self-Refresh (PASR)
- Asynchronous reset for power up
- Precharge: auto precharge option for each burst access
- Operating case temperature : $-40^{\circ}\text{C} \leq \text{TCase} \leq 95^{\circ}\text{C}$
- Support auto-refresh and self-refresh mode

- Average Refresh Period: 7.8 μs at $-40^{\circ}\text{C} \leq \text{TCase} \leq 85^{\circ}\text{C}$; 3.9 μs at $85^{\circ}\text{C} < \text{TCase} \leq 95^{\circ}\text{C}$
- Fine granularity refresh 2x, 4x mode for smaller tRFC
- Programmable data strobe preambles
- Command Address (CA) Parity is supported
- Write Cyclic Redundancy Code (CRC) is supported
- hPPR and sPPR are supported
- Connectivity test mode (TEN) is supported
- Gear Down Mode
- Output driver calibration through ZQ pin (RZQ: 240ohm \pm 1%)
- JEDEC JESD-79-4 compliant
- RoHS compliant

Note:

The functionality described and the timing specifications included in this datasheet are for the DLL Enabled mode of operation (normal operation), unless specifically stated otherwise.

1.3 Ordering Options

Table 1-1 Device Ordering Information

Part Number	Organization	Data Rate
CXDQ3A8AM-WG	1G x 8	2666 Mbps
CXDQ3BFAM-WG	512M x 16	2666 Mbps

1.4 Part Number Decoding

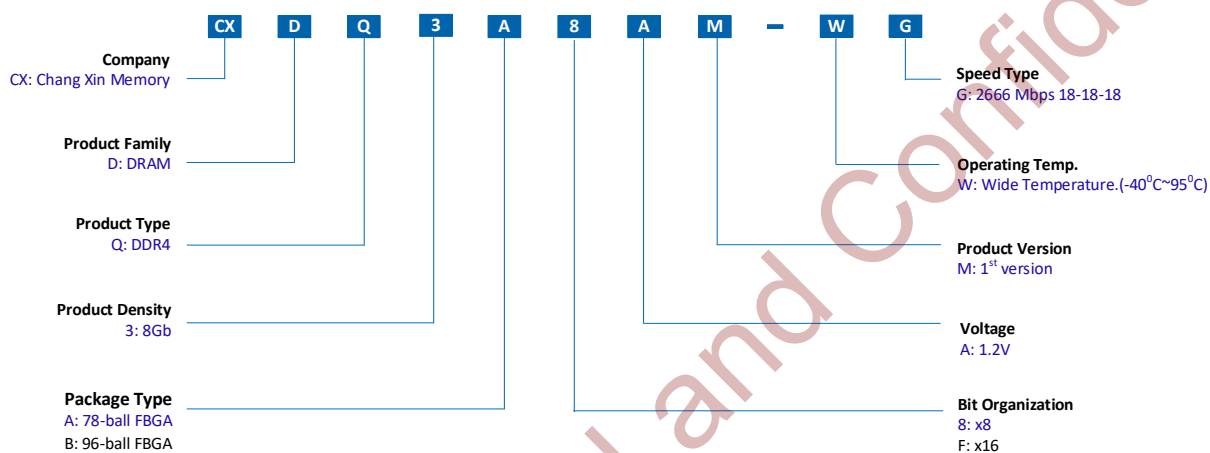

1.5 Address Table

Table 1-2 8Gb Addressing Table

Parameter	1Gb x8	512 Mb x16
Number of Bank Groups	4	2
Number of Banks per Bank Group	4	4
Bank Group Address	BG0~BG1	BG0
Bank Address per Bank Group	BA0~BA1	BA0~BA1
Row Address	A0~A15	A0~A15
Column Address	A0~A9	A0~A9
Page Size	1KB	2KB

2. DDR4 SDRAM Package Specifications

This chapter will mainly introduce the package dimension and ballout in x8 and x16 configurations which may help to match your device.

- [DDR4 SDRAM Package Dimension on Page 12](#)
- [DDR4 SDRAM x8 Ballout Using MO-207 on Page 14](#)
- [DDR4 SDRAM x16 Ballout Using MO-207 on Page 16](#)
- [Pinout Description on Page 17](#)

CXMT Privileged and Confidential

2.1 DDR4 SDRAM Package Dimension

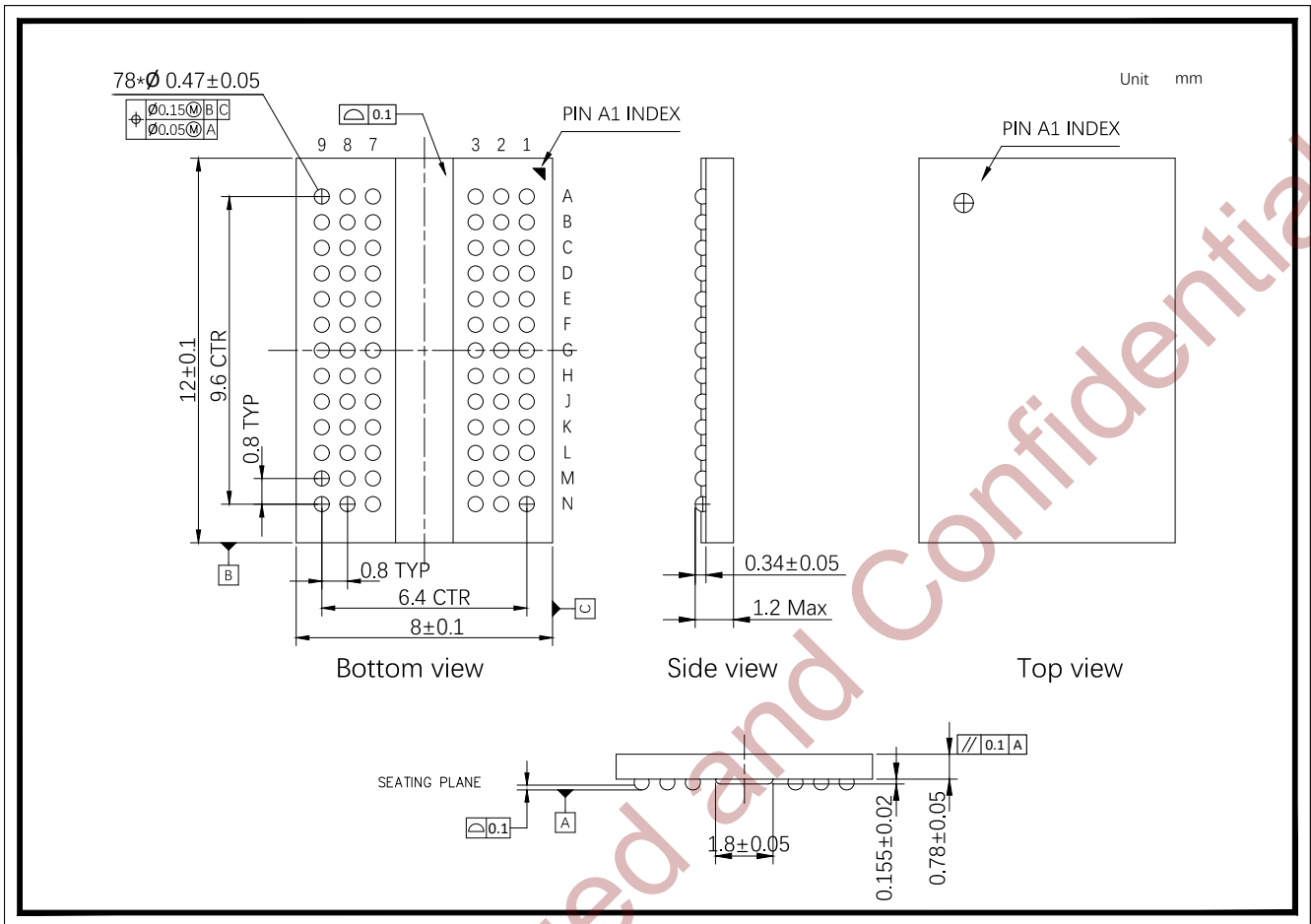

Figure 2-1 78-Ball FBGA - x8 Component

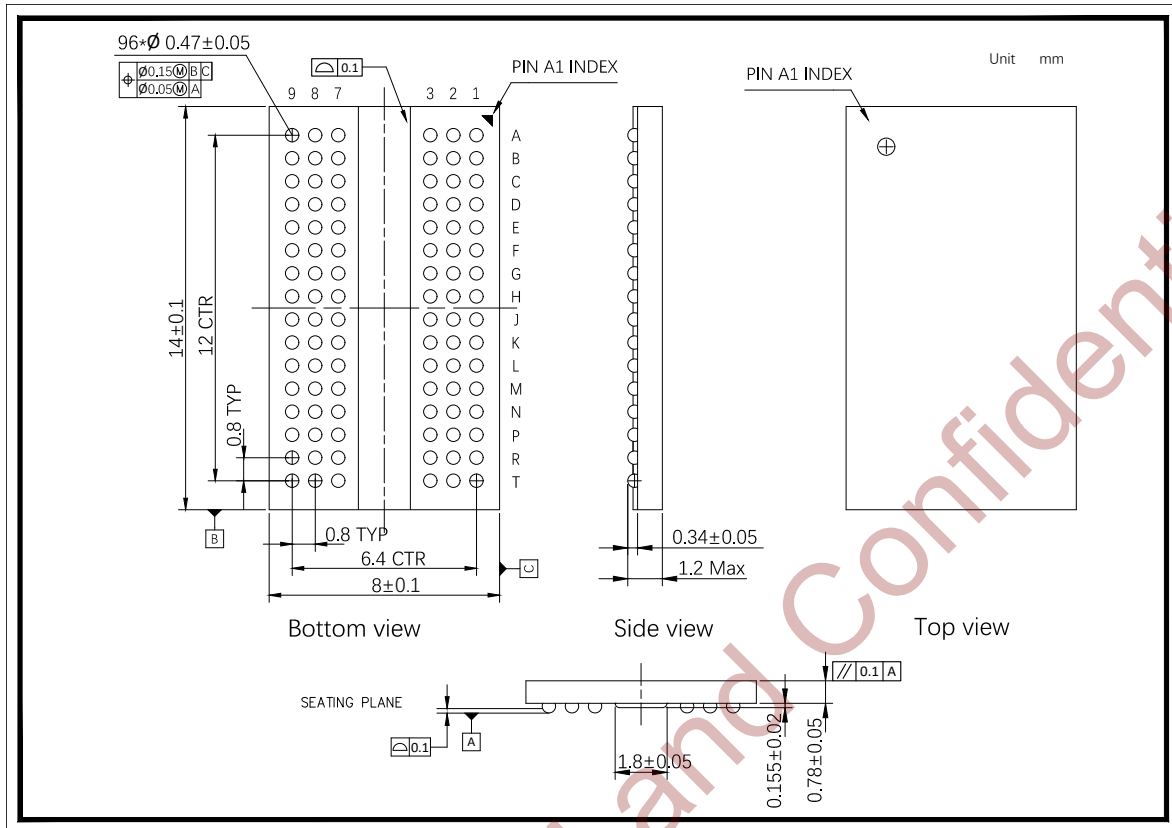

Figure 2-2 96-Ball FBGA - x16 Component

2.2 DDR4 SDRAM x8 Ballout Using MO-207

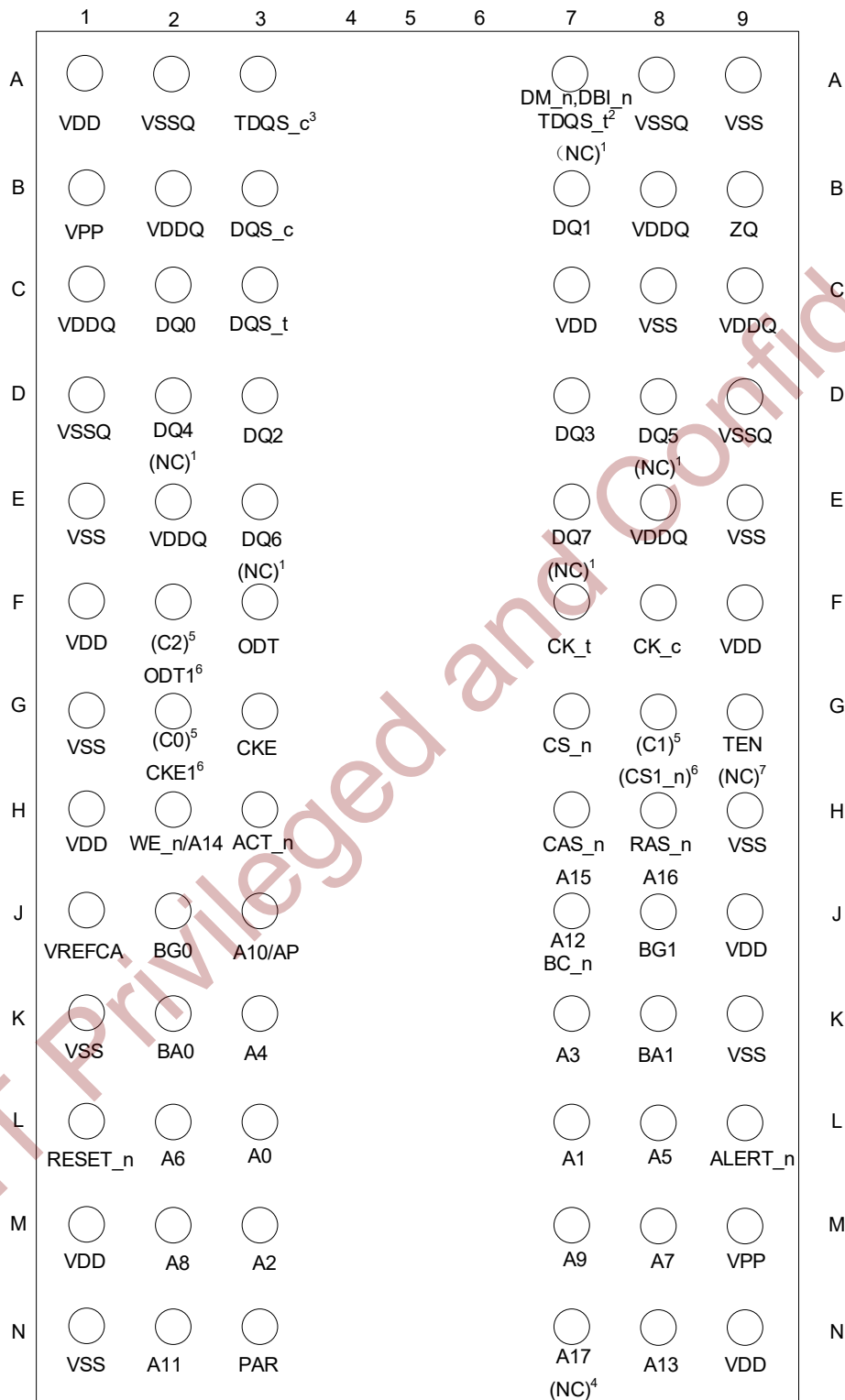

Figure 2-3 DDR4 Ball Assignments for the x8 Component

Note:

- 1 These pins are not connected for the x4 configuration.
- 2 TDQS_t is not valid for the x4 configuration.
- 3 TDQS_c is not valid for the x4 configuration.
- 4 A17 is only defined for the x4 configuration.
- 5 These pins are for stacked component such as 3DS. For mono package, these pins are NC.
- 6 ODT1 / CKE1 / CS1_n are used together only for DDP.
- 7 TEN is optional for 8Gb and above. This pin is not connected if TEN is not supported.

CXMT Privileged and Confidential

2.3 DDR4 SDRAM x16 Ballout Using MO-207

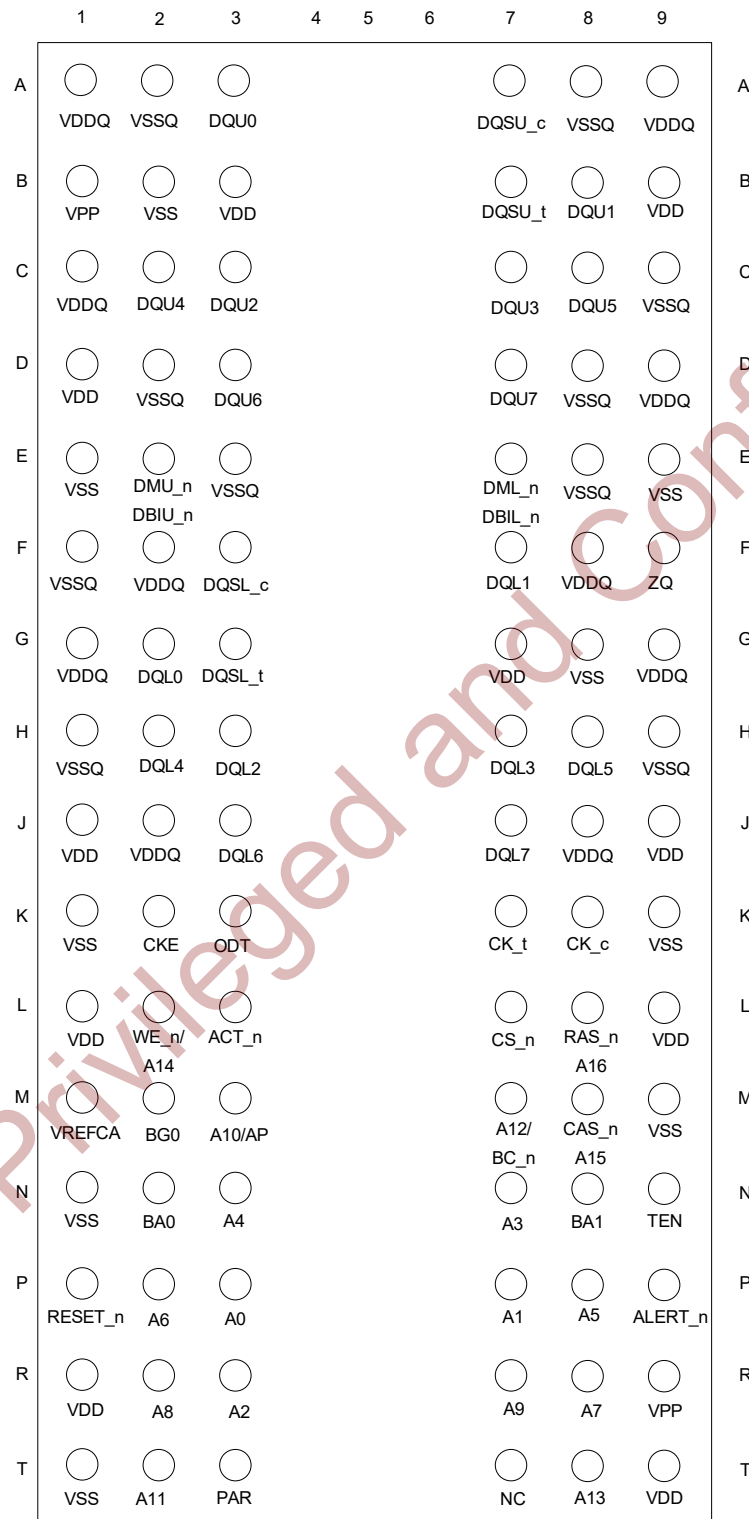

Figure 2-4 DDR4 Ball Assignments for the x16 Component

2.4 Pinout Description

Symbol	Type	Function
CK_t, CK_c	Input	Clock: CK_t and CK_c are differential clock inputs. All address and control input signals are sampled on the crossing of the positive edge of CK_t and negative edge of CK_c
CKE	Input	Clock Enable: CKE High activates, and CKE Low deactivates, internal clock signals and device input buffers and output drivers. Taking CKE Low provides Precharge Power-Down and Self-Refresh operation (all banks idle), or Active Power-Down (row Active in any bank). CKE is synchronous for Self-Refresh exit. After VREFCA and Internal DQ Vref have become stable during the power on and initialization sequence, they must be maintained during all operations (including Self-Refresh). CKE must be maintained high throughout Read and Write accesses. Input buffers, excluding CK_t, CK_c, ODT and CKE are disabled during power-down. Input buffers, excluding CKE, are disabled during Self-Refresh
CS_n	Input	Chip Select: All commands are masked when CS_n is registered High. CS_n provides for external Rank selection on systems with multiple Ranks. CS_n is considered part of the command code
ODT	Input	On Die Termination: ODT (registered High) enables RTT_NOM termination resistance internal to the DDR4 SDRAM. When enabled, ODT is only applied to each DQ, DQS_t, DQS_c and DM_n/DBI_n/TDQS_t, NU/TDQS_c (When TDQS is enabled via Mode Register A11=1 in MR1) signal for x8 configurations. For x16 configuration ODT is applied to each DQ, DQSU_t, DQSU_c, DQSL_t, DQSL_c, DMU_n, and DML_n signal. The ODT pin will be ignored if MR1 is programmed to disable RTT_NOM
ACT_n	Input	Activation Command Input: ACT_n defines the Activation command being entered along with CS_n. The input into RAS_n/A16, CAS_n/A15 and WE_n/A14 will be considered as Row Address A16, A15 and A14
RAS_n/A16 CAS_n/A15 WE_n/A14	Input	Command Inputs: RAS_n/A16, CAS_n/A15 and WE_n/A14 (along with CS_n) define the command being entered. Those pins have multi function. For example, for activation with ACT_n Low, those are Addressing like A16, A15 and A14 but for non-activation command with ACT_n High, those are command pins for Read, Write and other commands defined in Command Truth Table
DM_n/DBI_n, TDQS_t, (DMU_n/ DBIU_n), (DML_n/ DBIL_n)	Input/Output	Input Data Mask and Data Bus Inversion: DM_n is an input mask signal for Write data. Input data is masked when DM_n is sampled Low coincident with that input data during a Write access. DM_n is sampled on both edges of DQS. DM is muxed with DBI function by Mode Register A10, A11, A12 setting in MR5. For x8 device, the function of DM or TDQS is enabled by Mode Register A11 setting in MR1. DBI_n is an input/output identifying whether to store/output the true or inverted data. If DBI_n is Low, the data will be stored/output after inversion inside the DDR4 SDRAM and not inverted if DBI_n is High. TDQS is only supported in X8

Symbol	Type	Function
BG0 - BG1	Input	Bank Group Inputs: BG0 - BG1 define to which bank group an Active, Read, Write or Precharge command is being applied. BG0 also determines which mode register is to be accessed during a MRS cycle. x4/x8 have BG0 and BG1, but x16 has only BG0
BA0 - BA1	Input	Bank Address Inputs: BA0 - BA1 define to which bank an Active, Read, Write or Precharge command is being applied. Bank address also determines which mode register is to be accessed during a MRS cycle.
A0 - A16	Input	Address Inputs: Provide the row address for ACTIVATE commands and the column address for Read/Write commands to select one location out of the memory array in the respective bank. (A10/AP, A12/BC_n, RAS_n/A16, CAS_n/A15 and WE_n/A14 have additional functions, see corresponding entries in this table. The address inputs also provide the op-code during Mode Register Set commands.
A10/AP	Input	Auto-precharge: A10 is sampled during Read/Write commands to determine whether Autoprecharge should be performed to the accessed bank after the Read/Write operation. (High: Autoprecharge; Low: no Autoprecharge). A10 is sampled during a Precharge command to determine whether the Precharge applies to one bank (A10 Low) or all banks (A10 High). If only one bank is to be precharged, the bank is selected by bank addresses.
A12/BC_n	Input	Burst Chop: A12/BC_n is sampled during Read and Write commands to determine if burst chop (on-the-fly) will be performed. (High, no burst chop; Low: burst chopped). See "Command Truth Table" of Operation Guide for details.
RESET_n	Input	Active Low Asynchronous Reset: Reset is active when RESET_n is Low, and inactive when RESET_n is High. RESET_n must be High during normal operation. RESET_n is a CMOS rail to rail signal with DC high and low at 80% and 20% of VDD
DQ	Input/Output	Data Input/ Output: Bi-directional data bus. If CRC is enabled via mode register then CRC code is added at the end of Data Burst. Any DQ from DQ0~DQ3 may indicate the internal Vref level during test via Mode Register Setting MR4 A4=High. During this mode, RTT value should be set to Hi-Z. Refer to vendor specific data sheets to determine which DQ is used.
DQS_t, DQS_c, DQSU_t, DQSU_c, DQSL_t, DQSL_c	Input/Output	Data Strobe: output with Read data, input with Write data. Edge-aligned with Read data, centered-aligned with Write data. For the x16, DQSL corresponds to the data on DQL0-DQL7; DQSU corresponds to the data on DQU0-DQU7. The data strobe DQS_t, DQSL_t and DQSU_t are paired with differential signals DQS_c, DQSL_c, and DQSU_c, respectively, to provide differential pair signaling to the system during Reads and Writes. DDR4 SDRAM supports differential data strobe only and does not support single-ended.

Symbol	Type	Function
TDQS_t, TDQS_c	Output	Termination Data Strobe: TDQS_t/TDQS_c is applicable for x8 DRAMs only. When enabled via Mode Register A11 = 1 in MR1, the DRAM will enable the same termination resistance function on TDQS_t/TDQS_c that is applied to DQS_t/DQS_c. When disabled via mode register A11 = 0 in MR1, DM/DBI/TDQS will provide the data mask function or Data Bus Inversion depending on MR5; A11, A12, A10 and TDQS_c is not used. x4/ x16 DRAMs must disable the TDQS function via mode register A11 = 0 in MR1.
PAR	Input	Command and Address Parity Input: DDR4 Supports Even Parity Check in DRAMs with MR setting. Once it is enabled via Register in MR5, then DRAM calculates Parity with ACT_n,RAS_n/A16,CAS_n/A15,WE_n/A14,BG0-BG1,BA0-BA1,A17-A0. Input parity should maintain at the rising edge of the clock and at the same time with command & address with CS_n Low
ALERT_n	Input/Output	ALERT: It has multi functions such as CRC error flag, Command and Address Parity error flag as output signal. If there is error in CRC, then Alert_n goes Low for the period time interval and goes back High. If there is error in Command Address Parity Check, then ALERT_n goes Low for relatively long period until on going DRAM internal recovery transaction to complete. During Connectivity Test mode, this pin works as an input. Using this signal or not is dependent on system. In case of not connected as Signal, ALERT_n pin must be bounded to VDD on board.
TEN	Input	Connectivity Test Mode Enable: Required on X16 devices and optional input on x4/x8 with densities equal to or greater than 8Gb. High in this pin will enable Connectivity Test Mode operation along with other pins. It is a CMOS rail to rail signal with AC high and low at 80% and 20% of VDD. Using this signal or not is dependent on system. This pin may be DRAM internally pulled Low through a weak pull-down resistor to VSS.
NC		No Connect: No internal electrical connection is present.
VDDQ	Supply	DQ Power Supply: 1.2 V +/- 0.06 V
VSSQ	Supply	DQ Ground
VDD	Supply	Power Supply: 1.2 V +/- 0.06 V
VSS	Supply	Ground
VPP	Supply	DRAM Activating Power Supply: 2.5V (2.375V min, 2.75V max)
VREFCA	Supply	Reference voltage for CA
ZQ	Supply	Reference Pin for ZQ calibration

3. Absolute Maximum Ratings

3.1 Absolute Maximum DC Ratings

Symbol	Parameter	Min	Max	Unit	Note
VDD	Voltage on VDD pin relative to Vss	-0.3	1.5	V	1,3
VDDQ	Voltage on VDDQ pin relative to Vss	-0.3	1.5	V	1,3
VPP	Voltage on VPP pin relative to Vss	-0.3	3.0	V	4
V _{IN} , V _{OUT}	Voltage on any pin except VrefCA relative to Vss	-0.3	1.5	V	1,3,5
T _{STG}	Storage Temperature	-55	100	°C	1,2

Note:

- 1 Stresses greater than those listed under “Absolute Maximum Ratings” may cause permanent damage to the device. This is a stress rating only and functional operation of the device at these or any other conditions above those indicated in the operational sections of this specification is not implied. Exposure to absolute maximum rating conditions for extended periods may affect reliability.
- 2 Storage Temperature is the case surface temperature on the center/top side of the DRAM. For the measurement conditions, please refer to JEDEC51-2 standard.
- 3 VDD and VDDQ must be within 300 mV of each other at all times; and VREFCA must be not greater than 0.6*VDDQ, When VDD and VDDQ are less than 500 mV; VREF may be equal to or less than 300 mV.
- 4 VPP must be equal or greater than VDD/VDDQ at all times.
- 5 Overshoot area above 1.5V is specified in Section 4.3.5 and Section 4.3.6.

3.2 Recommended DC Operating Conditions

Table 3-1 Recommended DC Operating Conditions

Symbol	Parameter	Rating			Unit	Note
		Min	Typ.	Max		
VDD	Supply voltage	1.14	1.2	1.26	V	1,2,3
VDDQ	Supply voltage for output	1.14	1.2	1.26	V	1,2,3
VPP	Wordline supply voltage	2.375	2.5	2.75	V	3

Note:

- 1 Under all conditions VDDQ must be less than or equal to VDD.
- 2 VDDQ tracks with VDD. AC parameters are measured with VDD and VDDQ tied together.
- 3 DC bandwidth is limited to 20MHz.

3.3 DRAM Component Operating Temperature Range

Table 3-2 Operating Temperature Range

Symbol	Parameter	Rating	Unit	Note
T _{OPER}	Wide Temperature Range	-40 ~ 95	°C	1,2,3

Note:

- 1 Operating Temperature TOPER is the case surface temperature on the center / top side of the DRAM. For measurement conditions, please refer to the JEDEC document JESD51-2.
- 2 The Wide Temperature Range specifies the temperatures where all DRAM specifications will be supported.
- 3 Some applications require operation of the wide temperature DRAMs in the extended temperature range (between 85 °C and 95 °C case temperature). Full specifications are guaranteed in this range, but the following additional conditions apply:
 - Refresh commands must be doubled in frequency, therefore reducing the Refresh interval tREFI to 3.9 μs. It is also possible to specify a component with 1X refresh (tREFI to 7.8μs) in the Extended Temperature Range. Please refer to the DIMM SPD for option availability.
 - If Self-Refresh operation is required in the Extended Temperature Range, then it is mandatory to either use the Manual Self-Refresh mode with Extended Temperature Range capability (MR2 A6 = 0 and MR2 A7 = 1) or enable the optional Auto Self-Refresh mode (MR2 A6 = 1 and MR2 A7 = 1).

4. AC & DC Input Measurement Levels

This chapter mainly defines voltage tolerance limits and AC&DC logic input levels for input signals to ensure the normal operation of DDR4 SDRAM.

- AC and DC Logic Input Levels for Single-ended Signals on [Page 24](#)
- AC and DC Input Measurement Levels: Vref Tolerances on [Page 25](#)
- AC and DC Logic Input Levels for CK Differential Signals on [Page 26](#)
- Slew Rate Definitions for CK Differential Input Signals on [Page 34](#)
- CK Differential Input Cross Point Voltage on [Page 37](#)
- CMOS rail to rail Input Levels on [Page 39](#)
- AC&DC Logic input levels for DQS Signals on [Page 40](#)

4.1 AC and DC Logic Input Levels for Single-ended Signals

Table 4-1 Single-ended AC and DC Input Levels for Command and Address

Symbol	Parameter	1600/1866/2133/2400		2666		Unit	Note
		Min	Max	Min	Max		
VIH.CA(DC75)	DC input logic high	VREFCA + 0.075	VDD	-	-	V	
VIL.CA(DC75)	DC input logic low	VSS	VREFCA - 0.075	-	-	V	
VIH.CA(DC65)	DC input logic high	-	-	VREFCA + 0.065	VDD	V	
VIL.CA(DC65)	DC input logic low	-	-	VSS	VREFCA - 0.065	V	
VIH.CA(AC100)	AC input logic high	VREF + 0.1	Note 2	-	-	V	1
VIL.CA(AC100)	AC input logic low	Note 2	VREF - 0.1	-	-	V	1
VIH.CA(AC90)	AC input logic high	-	-	VREF + 0.09	Note 2	V	1
VIL.CA(AC90)	AC input logic low	-	-	Note 2	VREF - 0.09	V	1
VREFCA(DC)	Reference voltage for ADD, CMD inputs	0.49*VDD	0.51*VDD	0.49*VDD	0.51*VDD	V	2,3

Note:

- 1 See "Overshoot and Undershoot Specifications"
- 2 The AC peak noise on VREFCA may not allow VREFCA to deviate from VREFCA(DC) by more than $\pm 1\%$ VDD (for reference :approx. $\pm 12\text{mV}$)
- 3 For reference : approx. $VDD/2 \pm 12\text{ mV}$

4.2 AC and DC Input Measurement Levels: Vref Tolerances

The DC-tolerance limits and AC-noise limits for the reference voltages V_{refCA} is illustrated in 1 below. It shows a valid reference voltage $V_{ref}(t)$ as a function of time. (V_{ref} stands for V_{refCA}).

$V_{ref}(DC)$ is the linear average of $V_{ref}(t)$ over a very long period of time (for example, 1 second). This average has to meet the min/max requirement in Table 4-1. Furthermore $V_{ref}(t)$ may temporarily deviate from $V_{ref}(DC)$ by no more than $\pm 1\% VDD$.

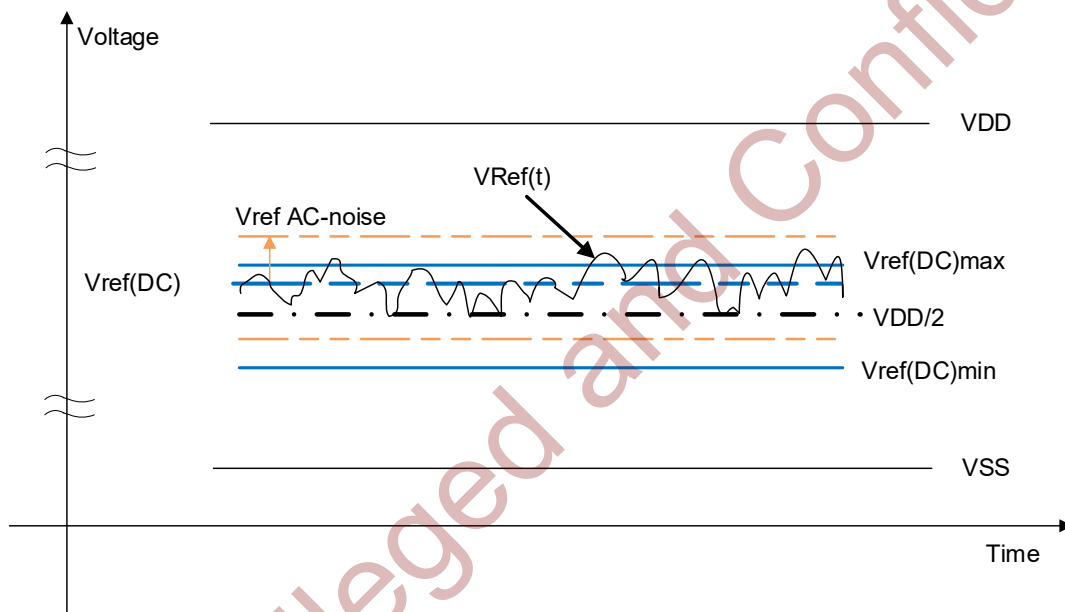

Figure 4-1 Illustration of $V_{ref}(DC)$ Tolerance and V_{ref} AC-noise Limits

The voltage levels for setup and hold time measurements $V_{IH}(AC)$, $V_{IH}(DC)$, $V_{IL}(AC)$ and $V_{IL}(DC)$ are dependent on V_{ref} .

“ V_{ref} ” should be understood as $V_{ref}(DC)$.

This clarifies that DC-variations of V_{ref} affect the absolute voltage a signal has to reach to achieve a valid high or low level, and therefore the time to which setup and hold is measured. System timing and voltage budgets need to account for $V_{ref}(DC)$ deviations from the optimum position within the data-eye of the input signals.

This also clarifies that the DRAM setup/hold specification and derating values need to include time and voltage associated with Vref AC-noise. Timing and voltage effects due to AC-noise on Vref up to the specified limit ($\pm 1\%$ of VDD) are included in DRAM timings and their associated deratings.

4.3 AC and DC Logic Input Levels for Differential Signals

4.3.1 Differential Signal Definition

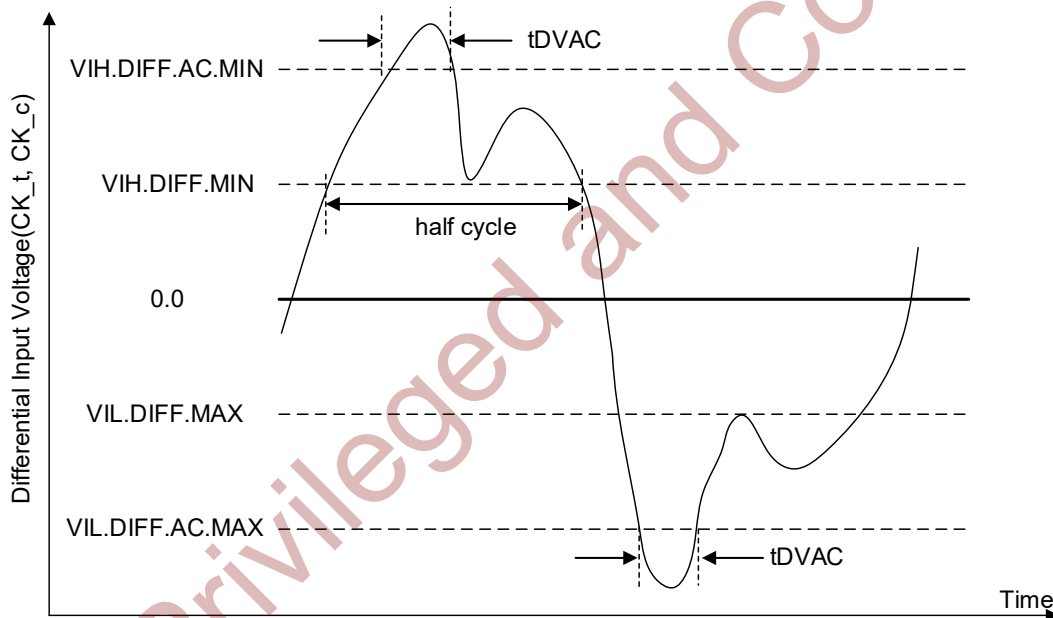

Figure 4-2 Definition of Differential AC-Swing and “Time above AC-Level” tDVAC

Note:

- 1 Differential signal rising edge from VIL.DIFF.MAX to VIH.DIFF.MIN must be monotonic slope.
- 2 Differential signal falling edge from VIH.DIFF.MIN to VIL.DIFF.MAX must be monotonic slope.

4.3.2 Differential Swing Requirements for Clock (CK_t - CK_c)

 Table 4-2 Differential Input Levels Requirements for CK_t - CK_c

Symbol	Parameter	1600/1866/2133		2400/2666		Unit	Note
		Min	Max	Min	Max		
VIHdiff	differential input high	+ 0.150	Note 3	+ 0.135	Note 3	V	1
VILdiff	differential input low	Note 3	- 0.150	Note 3	- 0.135	V	1
VIHdiff(AC)	differential input high ac	2 x (VIH(AC) - VREF)	Note 3	2 x (VIH(AC) - VREF)	Note 3	V	2
VILdiff(AC)	differential input low ac	Note 3	2 x (VIL(AC) - VREF)	Note 3	2 x (VIL(AC) - VREF)	V	2

Note:

- Used to define a differential signal slew-rate.
- for CK_t - CK_c use VIH.CA/VIL.CA(AC) of ADD/CMD and VREFCA;
- These values are not defined; however, the differential signals CK_t - CK_c, need to be within the respective limits (VIH.CA(DC) max, VIL.CA(DC)min) for single-ended signals as well as the limitations for overshoot and undershoot.

 Table 4-3 Allowed Time before Ringback (tDVAC) for CK_t - CK_c

Slew Rate [V/ns]	tDVAC [ps] @ VIH/Ldiff(AC) = 200mV		tDVAC [ps] @ VIH/Ldiff(AC) = TBDmV	
	Min	Max	Min	Max
> 4.0	120	-	TBD	-
4.0	115	-	TBD	-
3.0	110	-	TBD	-
2.0	105	-	TBD	-
1.8	100	-	TBD	-
1.6	95	-	TBD	-
1.4	90	-	TBD	-
1.2	85	-	TBD	-
1.0	80	-	TBD	-
<1.0	80	-	TBD	-

4.3.3 Single-ended Requirements for CK Differential Signals

Each individual component of a differential signal (CK_t, CK_c) has also to comply with certain requirements for single-ended signals.

CK_t and CK_c have to approximately reach VSEHmin/VSELmax (approximately equal to the ac-levels (VIH.CA(ac)/VIL.CA(ac)) for ADD/CMD signals) in every half-cycle.

Note that the applicable ac-levels for ADD/CMD might be different per speed-bin etc. E.g., if different value than VIH.CA(AC100)/VIL.CA(AC100) is used for ADD/CMD signals, then these ac-levels apply also for the single-ended signals CK_t and CK_c.

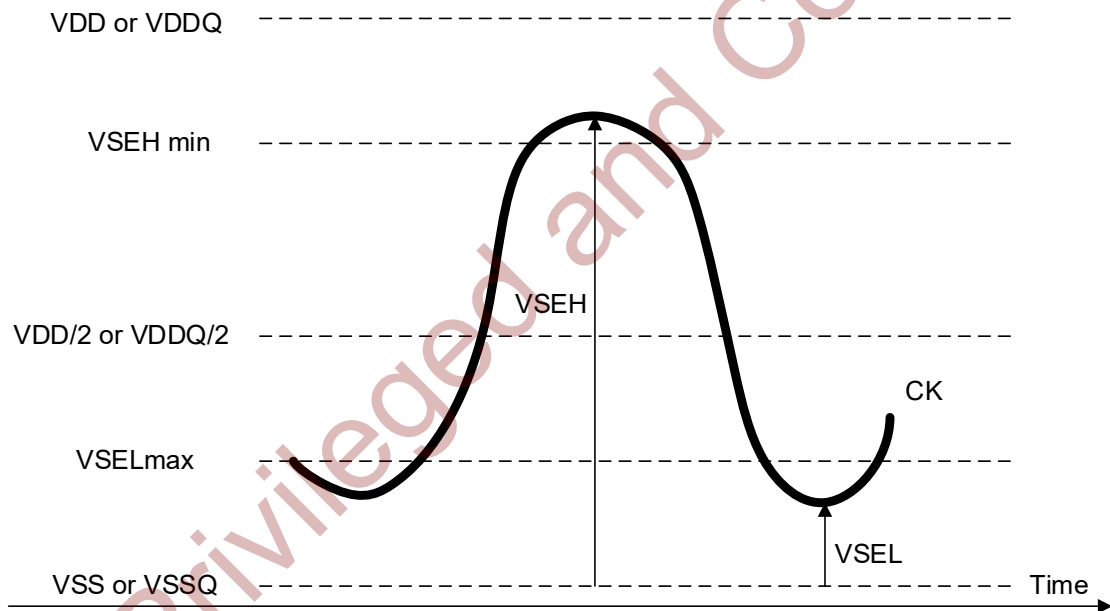

Figure 4-3 Single-ended Requirement for CK

Note that, while ADD/CMD signal requirements are with respect to VrefCA, the single-ended components of differential signals have a requirement with respect to VDD/2; this is nominally the same. The transition of single-ended signals through the ac-levels is used to measure setup time. For single-ended components of differential signals the requirement to reach VSELmax, VSEHmin has no bearing on timing, but adds a restriction on the common mode characteristics of these signals.

Table 4-4 Single-ended Levels Requirements for CK_t, CK_c

Symbol	Parameter	1600/1866/2133		2400/2666		Unit	Note
		Min	Max	Min	Max		
VSEH	Single-ended high-level for CK_t / CK_c	VDD/2 + 0.1	Note 3	VDD/2 + 0.095	Note 3	V	1,2
VSEL	Single-ended low-level for CK_t / CK_c	Note 3	VDD/2 - 0.1	Note 3	VDD/2 - 0.095	V	1,2

Note:

- 1 For CK_t-CK_c use VIH.CA/VIL.CA(AC) of ADD/CMD.
- 2 VIH(AC)/VIL(AC) for ADD/CMD is based on VREFCA.
- 3 These values are not defined, however the single-ended signals CK_t, CK_c need to be within the respective limits (VIH.CA(DC) max, VIL.CA(DC)min) for single-ended signals as well as the limitations for overshoot and undershoot.

4.3.4 Address, Command, and Control Overshoot and Undershoot Specifications

Table 4-5 AC Overshoot/Undershoot Specification for Address, Command, and Control Pins

Parameter	Symbol	1600/1866/2133/2400				2666	Unit	Note
Maximum peak amplitude above V_{AOS}	V_{AOSP}	0.06				TBD	V	
Upper boundary of overshoot area A_{AOS1}	V_{AOS}	VDD + 0.24				TBD	V	1
Maximum peak amplitude allowed for undershoot	V_{AUS}	0.3				TBD	V	
Maximum overshoot area per 1tCK Above V_{AOS}	A_{AOS2}	0.0083	0.0071	0.0062	0.0055	TBD	V-ns	
Maximum overshoot area per 1tCK Between VDD and V_{AOS}	A_{AOS1}	0.255	0.2185	0.1914	0.1699	TBD	V-ns	
Maximum undershoot area per 1tCK Below VSS	A_{AUS}	0.2644	0.2265	0.1984	0.1762	TBD	V-ns	
(A0-A13,A17,BG0-BG1,BA0-BA1,ACT_n,RAS_n/A16,CAS_n/A15,WE_n/A14,CS_n,CKE,ODT,C2-C0)								

Note:

The value of V_{AOS} matches VDD absolute max as defined in Section 3.1 if VDD equals VDD max as defined in Table 3-1. If VDD is above the recommended operating conditions, V_{AOS} remains at VDD absolute max as defined in Section 3.1 .

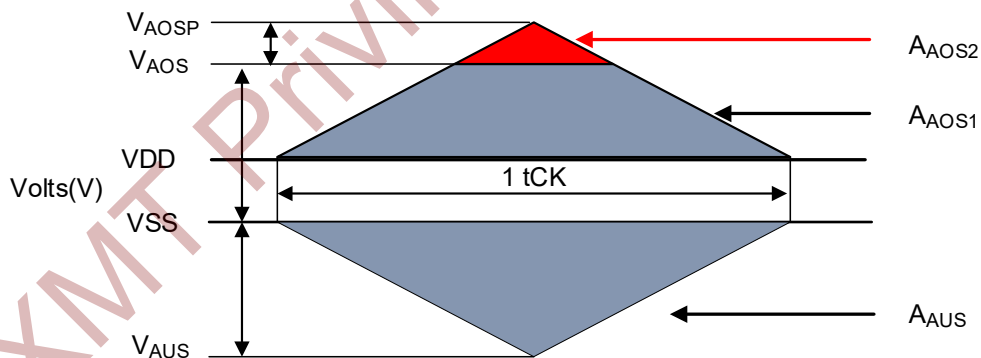

Figure 4-4 Address, Command, and Control Overshoot and Undershoot Definition

4.3.5 Clock Overshoot and Undershoot Specifications

Table 4-6 AC Overshoot/Undershoot Specification for Clock

Parameter	Symbol	1600/1866/2133/2400				2666	Unit	Note
Maximum peak amplitude above V_{COS}	V_{COSP}	0.06				TBD	V	
Upper boundary of overshoot area A_{COS1}	V_{COS}	VDD + 0.24				TBD	V	1
Maximum peak amplitude allowed for undershoot	V_{CUS}	0.3				TBD	V	
Maximum overshoot area per UI Above V_{COS}	A_{COS2}	0.0038	0.0032	0.0028	0.0025	TBD	V-ns	
Maximum overshoot area per 1tCK Between VDD and V_{COS}	A_{COS1}	0.1125	0.0964	0.0844	0.075	TBD	V-ns	
Maximum undershoot area per UI Below VSS	A_{CUS}	0.1144	0.098	0.0858	0.0762	TBD	V-ns	

(CK_t, CK_c)

Note:

The value of VAOS matches VDD absolute max as defined in Section 3.1 if VDD equals VDD max as defined in Table 3-1. If VDD is above the recommended operating conditions, VAOS remains at VDD absolute max as defined in Section 3.1

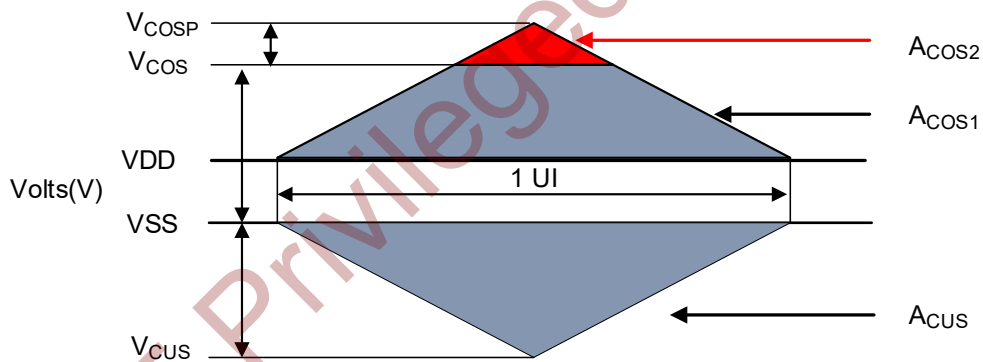

Figure 4-5 Clock Overshoot and Undershoot Definition

4.3.6 Data, Strobe and Mask Overshoot and Undershoot Specifications

Table 4-7 AC Overshoot/Undershoot Specification for Data, Strobe and Mask

Parameter	Symbol	1600/1866/2133/2400				Unit	Note
Maximum peak amplitude above V_{DOS}	V_{DOSP}	0.16				V	
Upper boundary of overshoot area A_{DOS1}	V_{DOS}	VDD + 0.24				V	1
Lower boundary of undershoot area A_{DUS1}	V_{DUS}	0.3				V	2
Maximum peak amplitude below V_{DUS}	A_{DUSP}	0.1	0.1	0.1	0.1	V-ns	
Maximum overshoot area per UI Above V_{DOS}	A_{DOS2}	0.0150	0.0129	0.0113	0.0100	V-ns	
Maximum overshoot area per 1UI Between VDDQ and V_{DOS}	A_{DOS1}	0.1050	0.0900	0.0788	0.0700	V-ns	
Maximum undershoot area per UI Between VSSQ and A_{DUS1}	A_{DUS1}	0.1050	0.0900	0.0788	0.0700	V-ns	
Maximum undershoot area per 1 UI below VDUS	A_{DUS2}	0.0150	0.0129	0.0113	0.0100	V-ns	
(DQ, DQS_t, DQS_c, DM_n, DBI_n, TDQS_t, TDQS_c)							
Parameter	Symbol	2666				Unit	Note
Maximum peak amplitude above V_{DOS}	V_{DOSP}	TBD				V	
Upper boundary of overshoot area A_{DOS1}	V_{DOS}	TBD				V	1
Lower boundary of undershoot area A_{DUS1}	V_{DUS}	TBD				V	2
Maximum peak amplitude below V_{DUS}	A_{DUSP}	TBD	TBD	TBD	TBD	V-ns	
Maximum overshoot area per UI Above V_{DOS}	A_{DOS2}	TBD	TBD	TBD	TBD	V-ns	
Maximum overshoot area per 1UI Between VDDQ and V_{DOS}	A_{DOS1}	TBD	TBD	TBD	TBD	V-ns	
Maximum undershoot area per UI Between VSSQ and A_{DUS}	A_{DUS1}	TBD	TBD	TBD	TBD	V-ns	
Maximum undershoot area per 1UI below V_{DUS}	A_{DUS2}	TBD	TBD	TBD	TBD	V-ns	
(DQ, DQS_t, DQS_c, DM_n, DBI_n, TDQS_t, TDQS_c)							

Note:

- 1 The value of VDOS matches (VIN, VOUT) max as defined in Section 3.1 if VDDQ equals VDDQ max as defined Table 3-1. If VDDQ is above the recommended operating conditions, VDOS remains at (VIN, VOUT) max as defined in Section 3.1
- 2 The value of VDUS matches (VIN, VOUT) min as defined in Section 3.1.

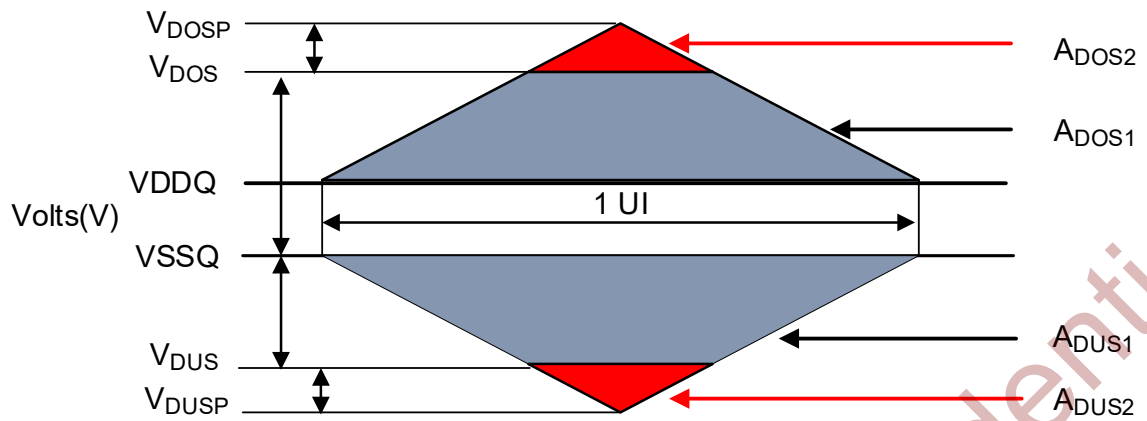

Figure 4-6 Data, Strobe and Mask Overshoot and Undershoot Definition

CXMT Privileged and Confidential

4.4 Slew Rate Definitions for Differential Input Signals

4.4.1 Slew Rate Definitions for Differential Input Signals (CK)

Input slew rate for differential signals (CK_t, CK_c) are defined and measured as shown in Table 4-8 and Figure 4-7.

CXMT Privileged and Confidential

Table 4-8 CK Differential Input Slew Rate Definition

Description	From	To	Defined by
Differential input slew rate for rising edge(CK_t-CK_c)	VILdiffmax	VIHdiffmin	$[VIHdiffmin - VILdiffmax] / \Delta TRdiff$
Differential input slew rate for falling edge(CK_t-CK_c)	VIHdiffmin	VILdiffmax	$[VIHdiffmin - VILdiffmax] / \Delta TFdiff$

Note: The differential signal (i, e., CK_t-CK_c) must be linear between these thresholds.

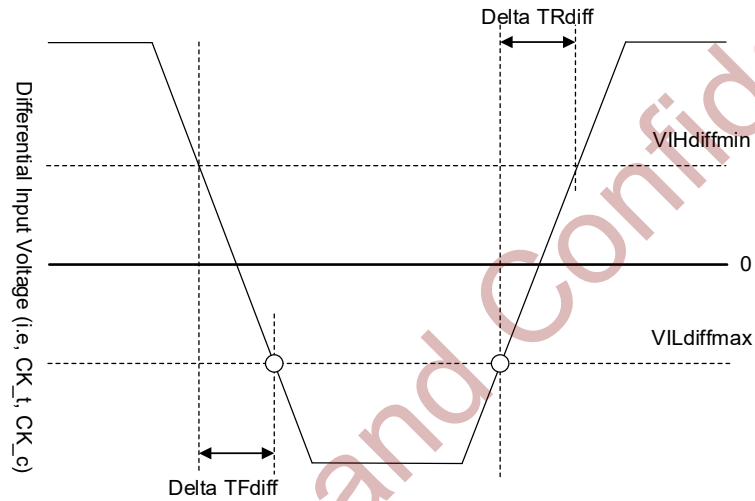

Figure 4-7 Differential Input Slew Rate Definition for CK_t, CK_c

4.4.2 Slew Rate Definition for Single-ended Input Signals (CMD/ADD)

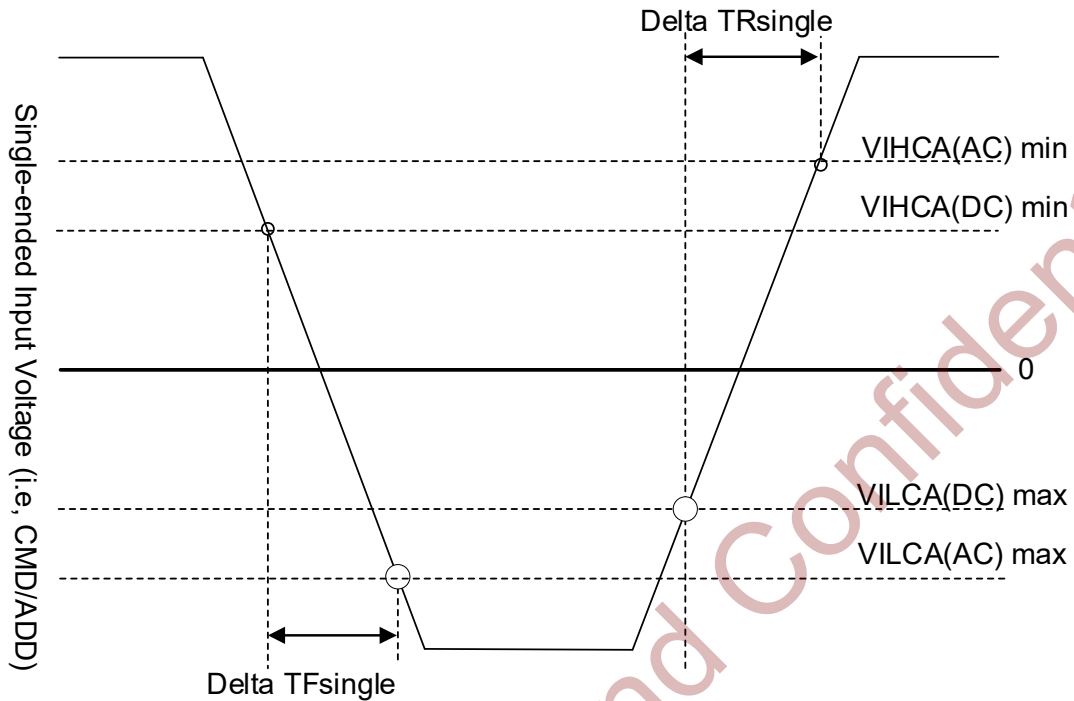

Figure 4-8 Single-ended Input Slew Rate Definition for CMD and ADD

Note:

- 1 Single-ended input slew rate for rising edge = $\{ V_{IHCA}(AC) \min - V_{ILCA}(DC) \max \} / \Delta T_{R \text{ single}}$.
- 2 Single-ended input slew rate for falling edge = $\{ V_{IHCA}(DC) \min - V_{ILCA}(AC) \max \} / \Delta T_{F \text{ single}}$.
- 3 Single-ended signal rising edge from $V_{ILCA}(DC) \max$ to $V_{IHCA}(DC) \min$ must be monotonic slope.
- 4 Single-ended signal falling edge from $V_{IHCA}(DC) \min$ to $V_{ILCA}(DC) \max$ must be monotonic slope.

4.5 CK Differential Input Cross Point Voltage

To guarantee tight setup and hold times as well as output skew parameters with respect to clock, each cross point voltage of differential input signals (CK_t, CK_c) must meet the requirements in Table 4-9. The differential input cross point voltage V_{ix} is measured from the actual cross point of true and complement signals to the midlevel between of VDD and VSS.

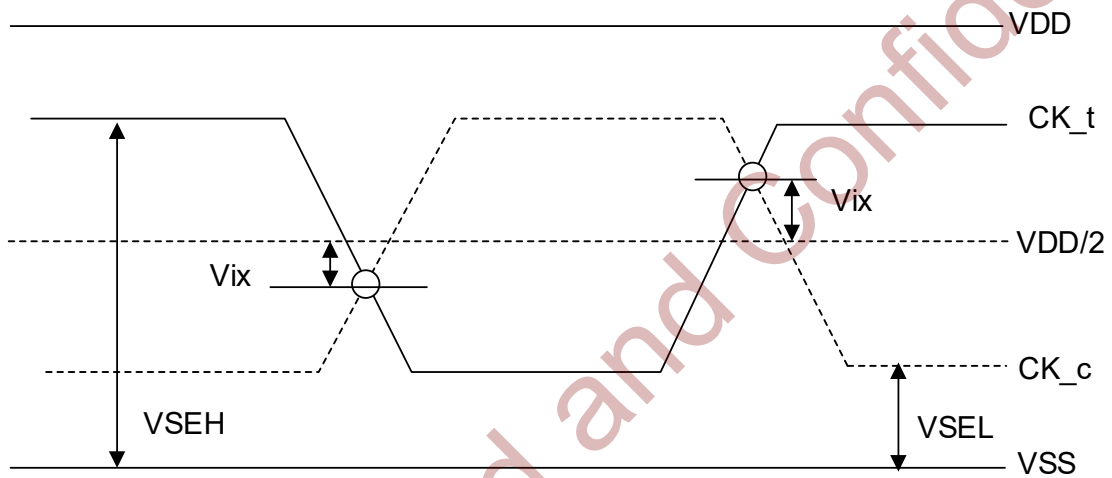

Figure 4-9 V_{ix} Definition (CK)

Table 4-9 Cross Point Voltage for CK Differential Input Signals

Symbol	Parameter	DDR4 -1600/1866/2133/2400			
		Min		Max	
		VSEL	VSEH	VSEL	VSEH
-	Area of VSEH, VSEL	$VSEL < VDD/2 - 145mV$	$VDD/2 - 145 mV \leq VSEL \leq VDD/2 - 100 mV$	$VDD/2 + 100 mV \leq VSEH \leq VDD/2 + 145 mV$	$VDD/2 + 145 mV < VSEH$
VIX(CK)	Differential Input Cross Point Voltage relative to VDD/2 for CK_t, CK_c	-120mV	$-(VDD/2 - VSEL) + 25 mV$	$(VSEH - VDD/2) - 25 mV$	120 mV

Symbol	Parameter	DDR4 -2666			
		Min		Max	
		VSEL	VSEH	VSEL	VSEH
-	Area of VSEH, VSEL	$VSEL < VDD/2 - 145mV$	$VDD/2 - 145 mV \leq VSEL \leq VDD/2 - 100 mV$	$VDD/2 + 90 mV \leq VSEH \leq VDD/2 + 145 mV$	$VDD/2 + 145 mV < VSEH$
VIX(CK)	Differential Input Cross Point Voltage relative to VDD/2 for CK_t, CK_c	-110mV	$-(VDD/2 - VSEL) + 30 mV$	$(VSEH - VDD/2) - 30 mV$	110 mV

4.6 CMOS Rail to Rail Input Levels for RESET_n

 Table 4-10 CMOS Rail to Rail Input Levels for RESET_n

Parameter	Symbol	Min	Max	Unit	Note
AC Input High Voltage	VIH(AC)_RESET	0.8*VDD	VDD	V	6
DC Input High Voltage	VIH(DC)_RESET	0.7*VDD	VDD	V	2
DC Input Low Voltage	VIL(DC)_RESET	VSS	0.3*VDD	V	1
AC Input Low Voltage	VIL(AC)_RESET	VSS	0.2*VDD	V	7
Rising time	TR_RESET	-	1.0	us	4
RESET pulse width	tPW_RESET	1.0	-	us	3,5

Note:

- 1 After RESET_n is registered Low, RESET_n level shall be maintained below VIL(DC)_RESET during tPW_RESET, otherwise, SDRAM may not be reset.
- 2 Once RESET_n is registered High, RESET_n level must be maintained above VIH(DC)_RESET, otherwise, SDRAM operation will not be guaranteed until it is reset asserting RESET_n signal Low.
- 3 RESET is destructive to data contents.
- 4 No slope reversal (ringback) requirement during its level transition from Low to High.
- 5 This definition is applied only "Reset Procedure at Power Stable".
- 6 Overshoot might occur. It should be limited by the Absolute Maximum DC Ratings.
- 7 Undershoot might occur. It should be limited by Absolute Maximum DC Ratings.

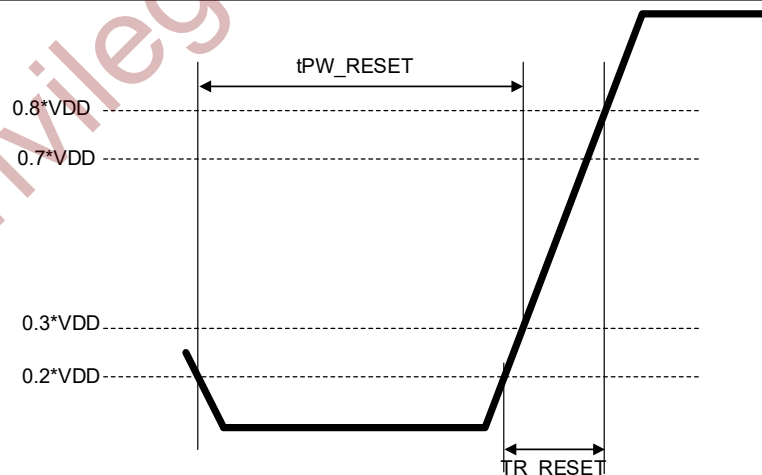
 Figure 4-10 RESET_n Input Slew Rate Definition

4.7 AC & DC Logic Input Levels for DQS Signals

4.7.1 Differential Signal Definition

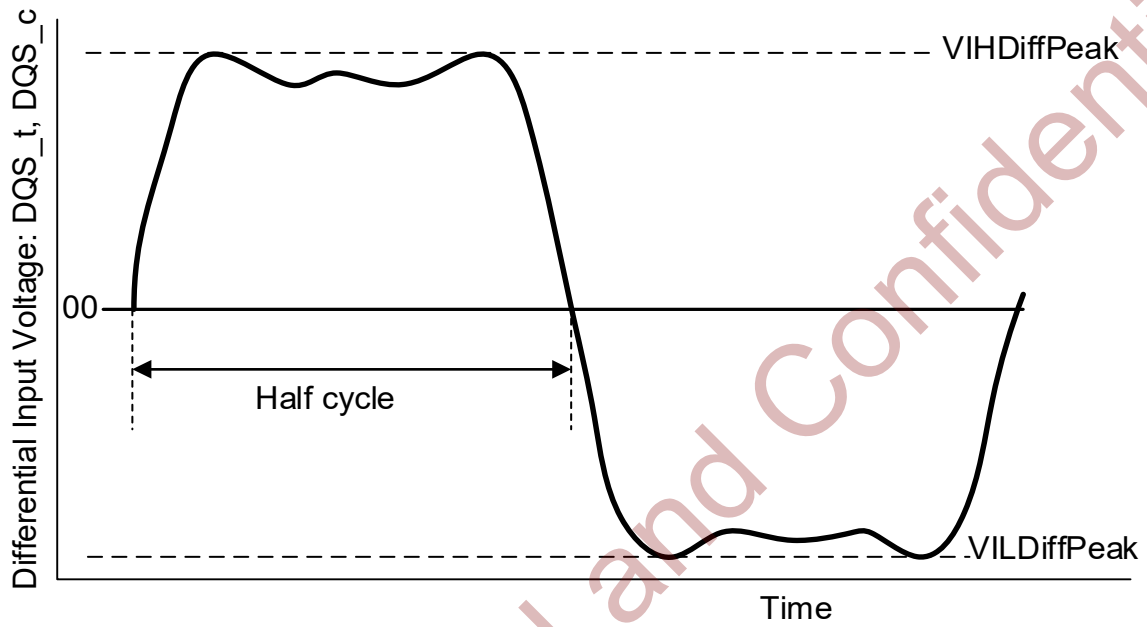

Figure 4-11 DQS Differential Input Signal AC-swing Level

4.7.2 Differential Swing Requirements for DQS (DQS_t - DQS_c)

Table 4-11 Differential Input Swing Requirements for DQS

Symbol	Parameter	1600/1866/2133		2400		2666		Unit	Note
		Min	Max	Min	Max	Min	Max		
VIHDiffPeak	VIH.DIFF.Peak Voltage	186	Note 2	160	Note 2	150	Note 2	mV	1
VILDiffPeak	VIL.DIFF.Peak Voltage	Note 2	-186	Note 2	-160	Note 2	-150	mV	1

Note:

- 1 Used to define a differential signal slew-rate.
- 2 These values are not defined; however, the differential signals DQS_t - DQS_c, need to be within the respective limits of Overshoot, Undershoot Specification for single-ended signals.”

4.7.3 Peak Voltage Calculation Method

The peak voltage of Differential DQS signals are calculated in a following equation.

$$VIH.DIFF.Peak\ Voltage = \text{Max}(f(t))$$

$$VIL.DIFF.Peak\ Voltage = \text{Min}(f(t))$$

$$f(t) = VDQS_t - VDQS_c$$

The $\text{Max}(f(t))$ or $\text{Min}(f(t))$ used to determine the midpoint which to reference the +/-35% window of the exempt non-monotonic signaling shall be the smallest peak voltage observed in all UI's.

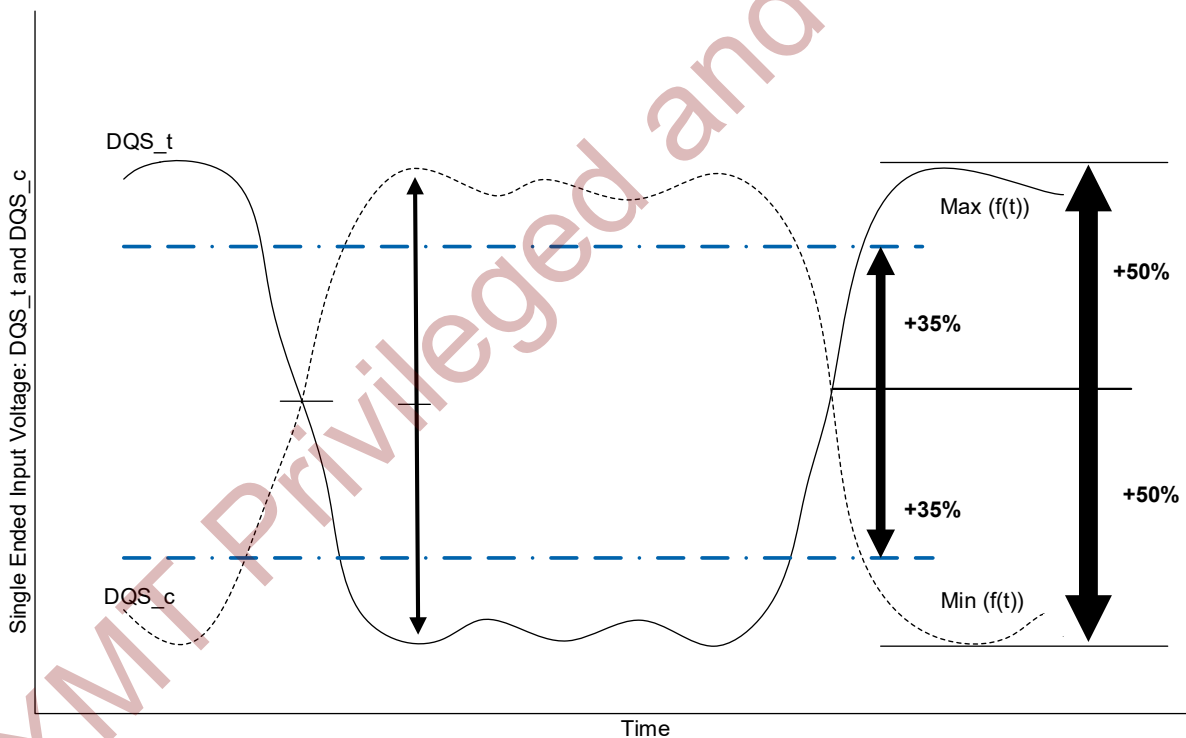

Figure 4-12 Definition of Differential DQS Peak Voltage and Range of Exempt Nonmonotonic Signaling

4.7.4 Differential Input Cross Point Voltage

To achieve tight RxMask input requirements as well as output skew parameters with respect to strobe, the cross point voltage of differential input signals (DQS_t, DQS_c) must meet the requirements in [Table 4-12](#). The differential input cross point voltage VIX_{DQS} (VIX_{DQS_FR} and VIX_{DQS_RF}) is measured from the actual cross point of DQS_t, DQS_c relative to the VDQSmid of the DQS_t and DQS_c signals.

VDQSmid is the midpoint of the minimum levels achieved by the transitioning DQS_t and DQS_c signals, and noted by VDQS_{trans}. VDQS_{trans} is the difference between the lowest horizontal tangent above VDQSmid of the transitioning DQS signals and the highest horizontal tangent below VDQSmid of the transitioning DQS signals.

A nonmonotonic transitioning signal's ledge is exempt or not used in determination of a horizontal tangent provided the said ledge occurs within +/- 35% of the midpoint of either VIH.DIFF. Peak Voltage (DQS_t rising) or VIL.DIFF. Peak Voltage (DQS_c rising), refer to [Figure 4-12](#). A secondary horizontal tangent resulting from a ring-back transition is also exempt in determination of a horizontal tangent. That is, a falling transition's horizontal tangent is derived from its negative slope to zero slope transition (point A in [Figure 4-13](#)) and a ring-back's horizontal tangent derived from its positive slope to zero slope transition (point B in [Figure 4-13](#)) is not a valid horizontal tangent; and a rising transition's horizontal tangent is derived from its positive slope to zero slope transition (point C in [Figure 4-13](#)) and a ring-back's horizontal tangent derived from its negative slope to zero slope transition (point D in [Figure 4-13](#)) is not a valid horizontal tangent.

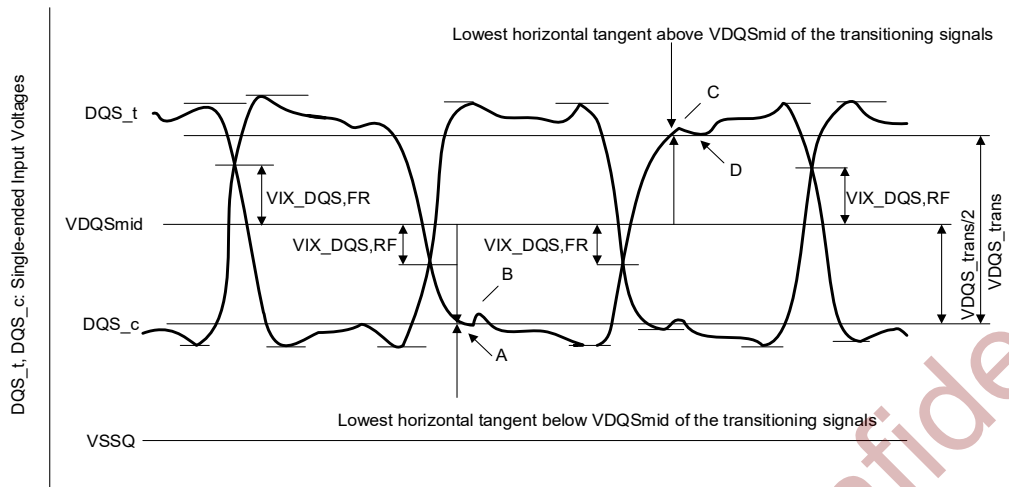

Figure 4-13 Vix Definition (DQS)

Table 4-12 Cross Point Voltage for DQS Differential Input Signals

Symbol	Parameter	1600/1866/2133/2400/2666		Unit	Note
		Min	Max		
Vix_DQS_ratio	DQS Differential input crosspoint voltage ratio	-	25	%	1,2
VDQSmid_to_Vcent	VDQSmid offset relative to Vcent_DQ(midpoint)	-	min(VIHdiff,50)	mV	3,4,5

Note:

- Vix_DQS_Ratio is DQS Vix crossing (Vix_DQS_FR or Vix_DQS_RF) divided by VDQS_trans. VDQS_trans is the difference between the lowest horizontal tangent above VDQSmid of the transitioning DQS signals and the highest horizontal tangent below VDQSmid of the transitioning DQS signals.
- VDQSmid will be similar to the VREFDQ internal setting value obtained during Vref Training if the DQS and DQs drivers and paths are matched.
- The maximum limit shall not exceed the smaller of VIHdiff minimum limit or 50mV.
- Vix measurements are only applicable for transitioning DQS_t and DQS_c signals when toggling data, preamble and high-z states are not applicable conditions.
- The parameter VDQSmid is defined for simulation and ATE testing purposes, it is not expected to be tested in a system.

4.7.5 Differential Input Slew Rate Definition

Input slew rate for differential signals (DQS_t, DQS_c) are defined and measured as shown in Figure 4-14 and Table 4-13.

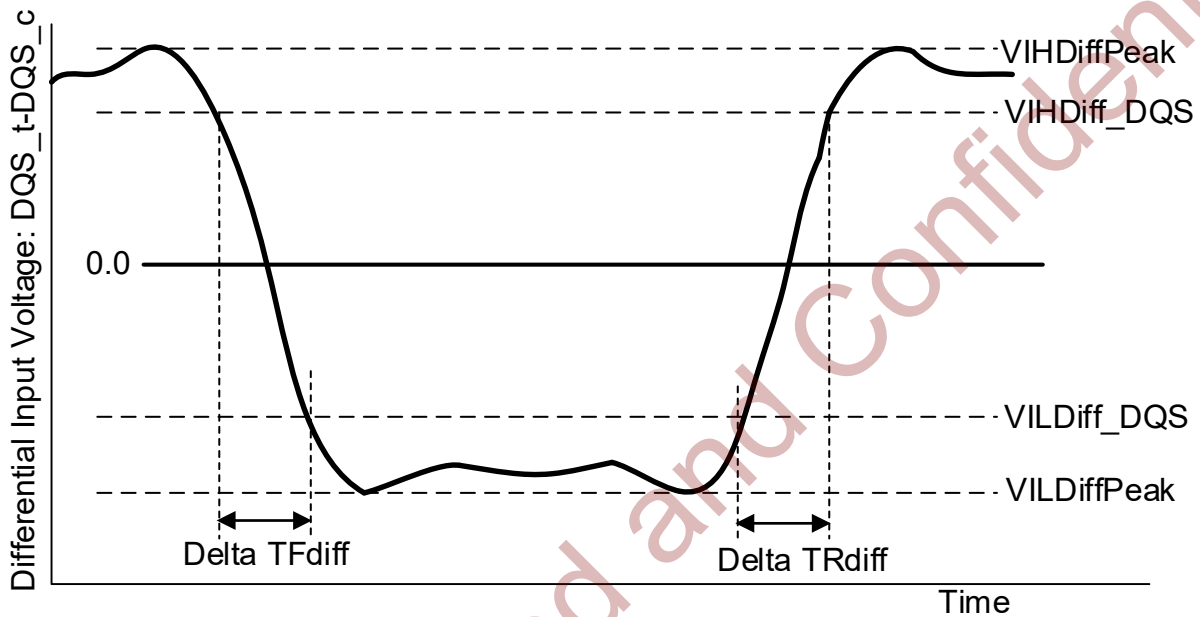

Figure 4-14 Differential Input Slew Rate Definition for DQS_t, DQS_c

Note:

- 1 Differential signal rising edge from VILDiff_DQS to VIHdiff_DQS must be monotonic slope.
- 2 Differential signal falling edge from VIHdiff_DQS to VILDiff_DQS must be monotonic slope.

Table 4-13 Differential Input Slew Rate Definition for DQS_t, DQS_c

Description	From	To	Defined by
Differential input slew rate for rising edge(DQS_t - DQS_c)	VILDiff_DQS	VIHdiff_DQS	$ VILDiff_DQS - VIHdiff_DQS / \Delta TRdiff$
Differential input slew rate for falling edge(DQS_t - DQS_c)	VIHdiff_DQS	VILDiff_DQS	$ VILDiff_DQS - VIHdiff_DQS / \Delta TRdiff$

Table 4-14 Differential Input Level for DQS_t, DQS_c

Symbol	Parameter	1600/1866/2133		2400/2666		Unit
		Min	Max	Min	Max	
VIHdiff_DQS	DC input logic high	136	-	130	-	mV
VILdiff_DQS	DC input logic low	-	-136	-	-130	mV

 Table 4-15 Differential Input Slew Rate for DQS_t, DQS_c

Symbol	Parameter	1600/1866/2133/2400		2666		Unit
		Min	Max	Min	Max	
SRIdiff	Differential Input Slew Rate	3	18	2.5	18	V/ns

5. AC & DC Output Measurement Levels

This chapter introduces the AC&DC output levels and slew rate for both single-ended and differential signals.

- [Output Driver DC Electrical Characteristics on Page 48](#)
- [Single-ended AC & DC Output Levels on Page 53](#)
- [Differential AC & DC Output Levels on Page 53](#)
- [Single-ended Output Slew Rate on Page 54](#)
- [Differential Output Slew Rate on Page 55](#)
- [Single-ended AC and DC Output Levels of Connectivity Test Mode on Page 58](#)
- [Test Load for Connectivity Test Mode Timing on Page 59](#)

5.1 Output Driver DC Electrical Characteristics

The DDR4 driver supports two different RON values. These RON values are referred as strong (low RON) and weak mode (high RON). A functional representation of the output buffer is shown in Figure 5-1 below. Output driver impedance RON is defined as the individual pull-up and pull-down resistors (RONPu and RONPd).

$$RON_{Pu} = \frac{VDDQ - V_{out}}{|I_{out}|} \text{ under the condition that } RON_{Pd} \text{ is off}$$

$$RON_{Pd} = \frac{V_{out}}{|I_{out}|} \text{ under the condition that } RON_{Pu} \text{ is off}$$

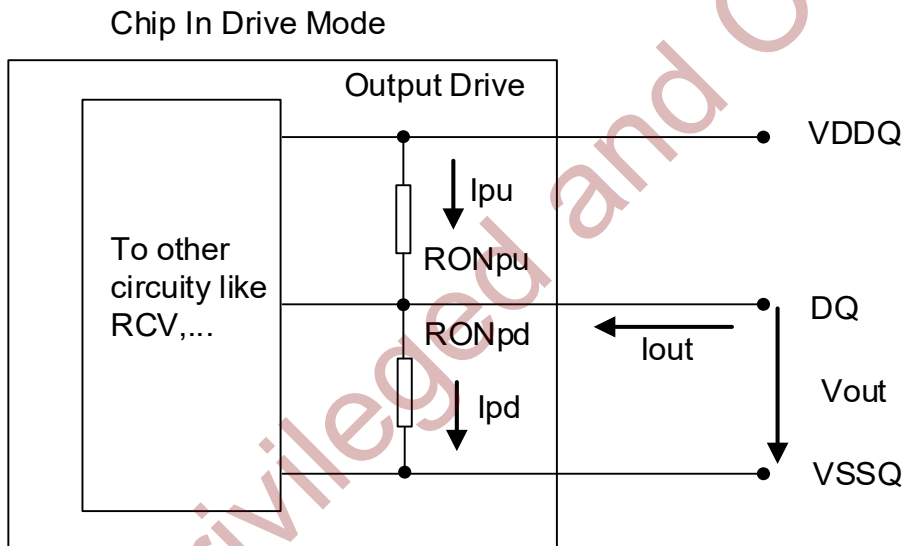

Figure 5-1 Output Driver

Table 5-1 Output Driver DC Electrical Characteristics, Assuming RZQ = 240ohm; Entire Operating Temperature Range; after Proper ZQ Calibration

RONNOM	Resistor	Vout	Min	Nom	Max	Unit	Note
34Ω	RON34Pd	VOLdc=0.5*VDDQ	0.73	1.0	1.1	RZQ/7	1,2
		VOMdc=0.8*VDDQ	0.83	1.0	1.1	RZQ/7	1,2
		VOHdc=1.1*VDDQ	0.83	1.0	1.25	RZQ/7	1,2
	RON34Pu	VOLdc=0.5*VDDQ	0.9	1.0	1.1	RZQ/7	1,2
		VOMdc=0.8*VDDQ	0.9	1.0	1.1	RZQ/7	1,2
		VOHdc=1.1*VDDQ	0.8	1.0	1.25	RZQ/7	1,2
48Ω	RON48Pd	VOLdc=0.5*VDDQ	0.73	1.0	1.1	RZQ/5	1,2
		VOMdc=0.8*VDDQ	0.83	1.0	1.1	RZQ/5	1,2
		VOHdc=1.1*VDDQ	0.83	1.0	1.25	RZQ/5	1,2
	RON48Pu	VOLdc=0.5*VDDQ	0.9	1.0	1.25	RZQ/5	1,2
		VOMdc=0.8*VDDQ	0.9	1.0	1.1	RZQ/5	1,2
		VOHdc=1.1*VDDQ	0.8	1.0	1.1	RZQ/5	1,2
Mismatch between pull-up and pull-down, MMPuPd		VOMdc=0.8*VDDQ	-10		17	%	1,2,3,4
Mismatch DQ-DQ within byte variation pull-up, MMPudd		VOMdc=0.8*VDDQ			10	%	1,2,4
Mismatch DQ-DQ within byte variation pull-up, MMPddd		VOMdc=0.8*VDDQ			10	%	1,2,4

Note:

- 1 The tolerance limits are specified after calibration with stable voltage and temperature. For the behavior of the tolerance limits if temperature or voltage changes after calibration, see following section on voltage and temperature sensitivity (TBD).
- 2 Pull-up and pull-dn output driver impedances are recommended to be calibrated at 0.8*VDDQ. Other calibration schemes may be used to achieve the linearity spec shown above, e.g. calibration at 0.5*VDDQ and 1.1*VDDQ.
- 3 Measurement definition for mismatch between pull-up and pull-down, MMPuPd : Measure RONPu and RONPd both at 0.8*VDD separately; RONnom is the nominal RON value.
- 4 $MMPuPd = [(RONPu - RONPd) / RONNOM] * 100$
- 5 RON variance range ratio to RON Nominal value in a given component, including DQS_t and DQS_c.
- 6 $MMPudd = [(RONPuMax - RONPuMin) / RONNOM] * 100$
- 7 $MMPddd = [(RONPdMax - RONPdMin) / RONNOM] * 100$
- 8 This parameter of x16 device is specified for Upper byte and Lower byte.

5.1.1 Alert_n Output Drive Characteristic

A functional representation of the output buffer is shown in the figure below. Output driver impedance RON is defined as follows:

$$RON_{Pd} = \frac{V_{out}}{|I_{out}|} \text{ under the condition that } RON_{Pu} \text{ is off}$$

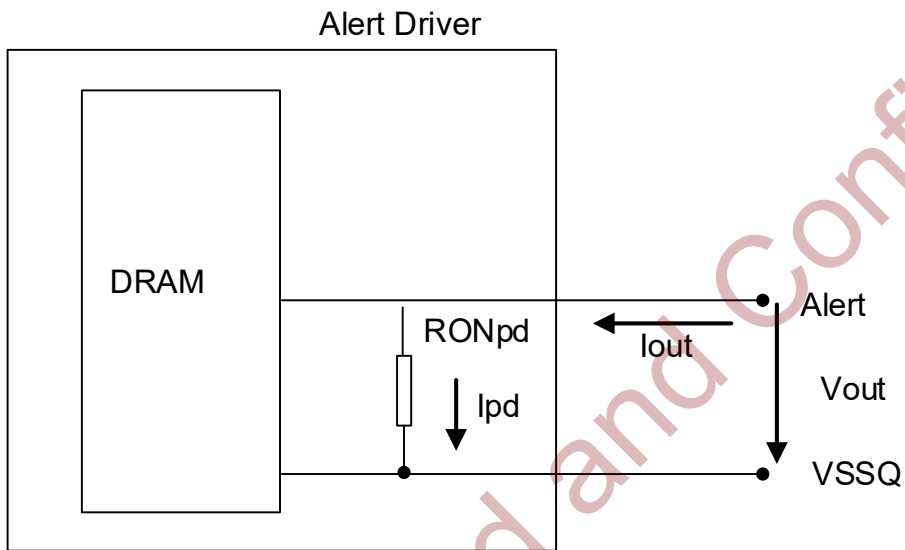

Resistor	Vout	Min	Max	Unit	Note
RON _{Pd}	VOLdc=0.1*VDDQ	0.3	1.2	34Ω	1
	VOMdc=0.8*VDDQ	0.3	1.2	34Ω	1
	VOHdc=1.1*VDDQ	0.4	1.4	34Ω	1

Note:

VDDQ voltage is at VDDQ DC. VDDQ DC definition is TBD.

5.1.2 Output Driver Characteristic of Connectivity Test (CT) Mode

Following output driver impedance RON will be applied Test Output Pin during Connectivity Test (CT) Mode. The individual pull-up and pull-down resistors (RONPu_CT and RONPd_CT) are defined as follows:

$$RON_{Pu_CT} = (VDDQ - VOUT) / |I_{out}|$$

$$RON_{Pd_CT} = VOUT / |I_{out}|$$

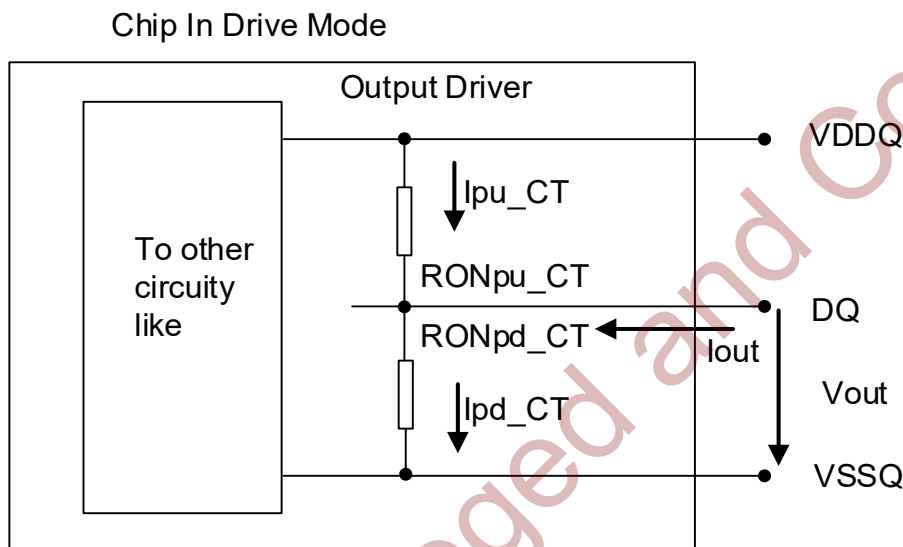

RON_{NOM_CT}	Resistor	Vout	Max	Units
34Ω	RONPd_CT	VOBdc=0.2*VDDQ	1.9	34Ω
		VOLdc=0.5*VDDQ	2.0	34Ω
		VOMdc=0.8*VDDQ	2.2	34Ω
		VOHdc=1.1*VDDQ	2.5	34Ω
	RONPu_CT	VOBdc=0.2*VDDQ	2.5	34Ω
		VOLdc=0.5*VDDQ	2.2	34Ω
		VOMdc=0.8*VDDQ	2.0	34Ω
		VOHdc=1.1*VDDQ	1.9	34Ω

Note:

Connectivity test mode uses un-calibrated drivers, showing the full range over PVT. No mismatch between pull up and pull down is defined.

CXMT Privileged and Confidential

5.2 Single-ended AC&DC Output Levels

Table 5-2 Single-ended AC & DC Output Levels

Symbol	Parameter	1600/1866/2133/2400/2666	Unit
VOH(DC)	DC output high measurement level (for IV curve linearity)	1.1 x VDDQ	V
VOM(DC)	DC output mid measurement level (for IV curve linearity)	0.8 x VDDQ	V
VOL(DC)	DC output low measurement level (for IV curve linearity)	0.5 x VDDQ	V
VOH(AC)	AC output high measurement level (for output SR)	(0.7 + 0.15) x VDDQ	V
VOL(AC)	AC output low measurement level (for output SR)	(0.7 - 0.15) x VDDQ	V

Note:

The swing of $\pm 0.15 \times VDDQ$ is based on approximately 50% of the static single-ended output peak-to-peak swing with a driver impedance of $RZQ/7\Omega$ and an effective test load of 50Ω to $VTT=VDDQ$.

5.3 Differential AC & DC Output Levels

Table 5-3 Differential AC & DC Output Levels

Symbol	Parameter	1600/1866/2133/2400/2666	Unit
VOHdiff(AC)	AC differential output high measurement level (for output SR)	+ 0.3 x VDDQ	V
VOLdiff(AC)	AC differential output low measurement level (for output SR)	- 0.3 x VDDQ	V

Note:

The swing of $\pm 0.3 \times VDDQ$ is based on approximately 50% of the static differential output peak-to-peak swing with a driver impedance of $RZQ/7\Omega$ and an effective test load of 50Ω to $VTT = VDDQ$ at each of the differential outputs.

5.4 Single-ended Output Slew Rate

With the reference load for timing measurements, output slew rate for falling and rising edges is defined and measured between VOL(AC) and VOH(AC) for single ended signals as shown in Table 5-4 and Figure 5-2.

Table 5-4 Single-ended Output Slew Rate Definition

Description	Measured		Defined by
	From	To	
Single ended output slew rate for rising edge	VOL(AC)	VOH(AC)	$[VOH(AC)-VOL(AC)]/\Delta TR_{se}$
Single ended output slew rate for falling edge	VOH(AC)	VOL(AC)	$[VOH(AC)-VOL(AC)]/\Delta TF_{se}$

Note:

Output slew rate is verified by design and characterization, and may not be subject to production test.

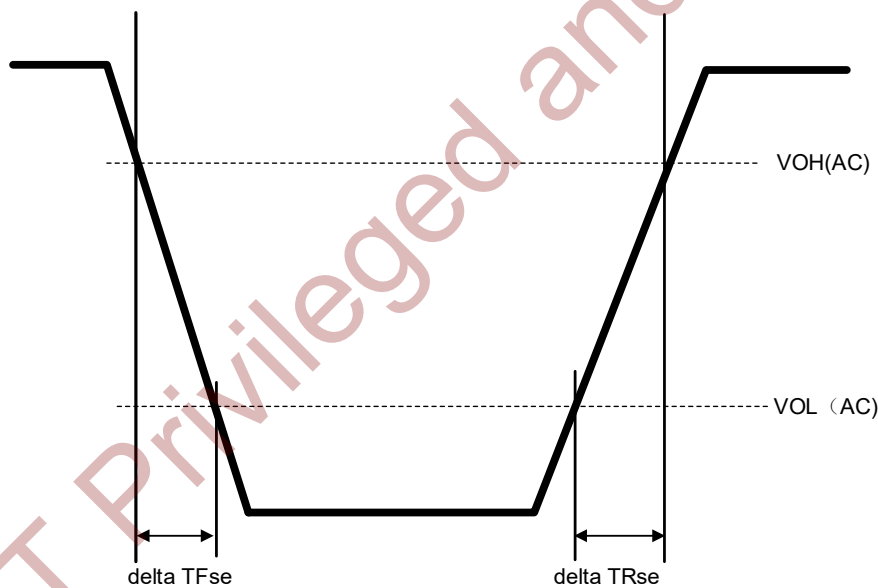

Figure 5-2 Single-ended Output Slew Rate Definition

Table 5-5 Single-ended Output Slew Rate

Parameter	Symbol	1866/2133/2400/2666		Unit
		Min	Max	
Single ended output slew rate	SRQse	4	9	V/ns

Description: SR: Slew Rate;Q: Query Output (like in DQ, which stands for Data-in, Query-Output)
se: Single-ended Signals;For RON = RZQ/7 setting

Note:

In two cases, a maximum slew rate of 12 V/ns applies for a single DQ signal within a byte lane.

- Case 1 is defined for a single DQ signal within a byte lane which is switching into a certain direction (either from high to low or low to high) while all remaining DQ signals in the same byte lane are static (i.e. they stay at either high or low).
- Case 2 is defined for a single DQ signal within a byte lane which is switching into a certain direction (either from high to low or low to high) while all remaining DQ signals in the same byte lane are switching into the opposite direction (i.e. from low to high or high to low respectively). For the remaining DQ signal switching into the opposite direction, the regular maximum limit of 9 V/ns applies).

5.5 Differential Output Slew Rate

With the reference load for timing measurements, output slew rate for falling and rising edges is defined and measured between VOLdiff(AC) and VOHdiff(AC) for differential signals as shown in Table 5-6 and Figure 5-3.

Table 5-6 Differential Output Slew Rate Definition

Description	Measured		Defined by
	From	To	
Differential output slew rate for rising edge	$V_{OLdiff}(AC)$	$V_{OHdiff}(AC)$	$[V_{OHdiff}(AC)-V_{OLdiff}(AC)]/\Delta TR_{diff}$
Differential output slew rate for falling edge	$V_{OHdiff}(AC)$	$V_{OLdiff}(AC)$	$[V_{OHdiff}(AC)-V_{OLdiff}(AC)]/\Delta TF_{diff}$

Note:

Output slew rate is verified by design and characterization, and may not be subject to production test.

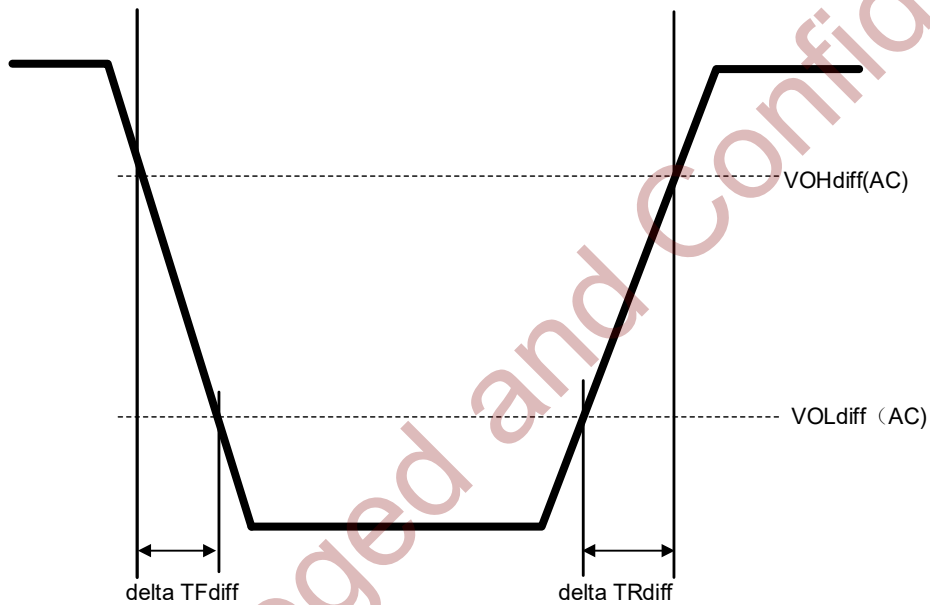

Figure 5-3 Differential Output Slew Rate Definition

Table 5-7 Differential Output Slew Rate

Parameter	Symbol	1866/2133/2400/2666		Unit
		Min	Max	
Differential output slew rate	SRQdiff	8	18	V/ns

Description:

SR: Slew Rate; Q: Query Output (like in DQ, which stands for Data-in, Query-Output);

diff: Differential Signals; For RON = RZQ/7 setting;

CXMT Privileged and Confidential

5.6 Single-ended AC and DC Output Levels of Connectivity Test Mode

Following output parameters will be applied for DDR4 SDRAM Output Signal during Connectivity Test Mode.

Table 5-8 Single-ended AC & DC Output Levels of Connectivity Test Mode

Symbol	Parameter	1600/1866/2133/2400/2666	Unit	Note
$V_{OH(DC)}$	DC output high measurement level (for IV curve linearity)	$1.1 \times VDDQ$	V	
$V_{OM(DC)}$	DC output mid measurement level (for IV curve linearity)	$0.8 \times VDDQ$	V	
$V_{OL(DC)}$	DC output low measurement level (for IV curve linearity)	$0.5 \times VDDQ$	V	
$V_{OB(DC)}$	DC output below measurement level (for IV curve linearity)	$0.2 \times VDDQ$	V	
$V_{OH(AC)}$	AC output high measurement level (for output SR)	$VTT + (0.1 \times VDDQ)$	V	1
$V_{OL(AC)}$	AC output below measurement level (for output SR)	$VTT - (0.1 \times VDDQ)$	V	1

Note:

The effective test load is 50Ω terminated by $VTT = 0.5 \times VDDQ$.

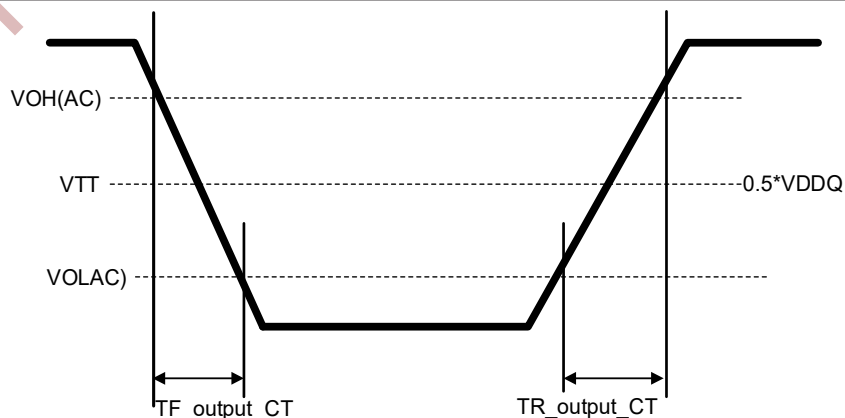

Figure 5-4 Output Slew Rate Definition of Connectivity Test Mode

Table 5-9 Single-ended Output Slew Rate of Connectivity Test Mode

Parameter	Symbol	1866/2133/2400/2666		Unit
		Min	Max	
Output signal Falling time	TF_output_CT	-	10	ns/V
Output signal Rising time	TR_output_CT	-	10	ns/V

5.7 Test Load for Connectivity Test Mode Timing

The reference load for ODT timings is defined in Figure 5-5.

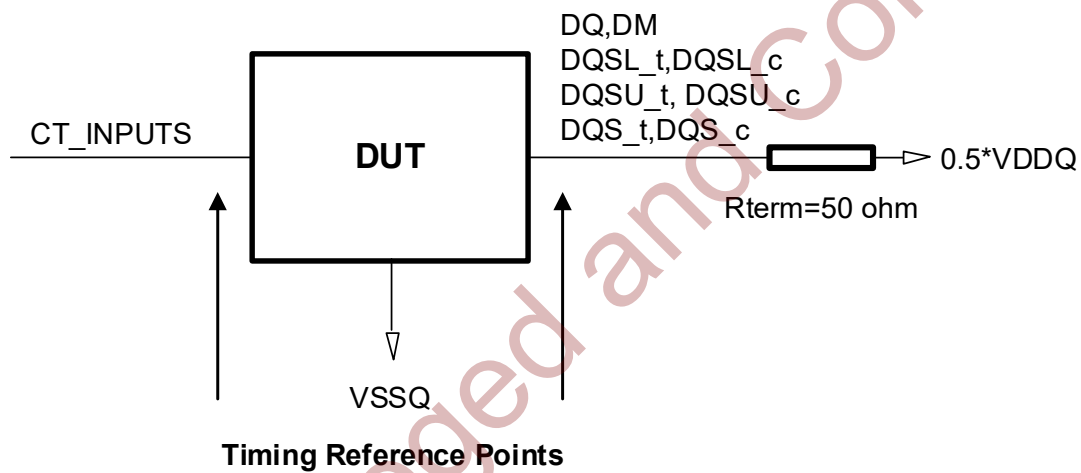

Figure 5-5 Connectivity Test Mode Timing Reference Load

6. Speed Bin

6.1 DDR4-2666 Speed Bins and Operations

Table 6-1 DDR4-2666 Speed Bins and Operations

Speed Bin			DDR4-2666		Unit	Note	
CL-nRCD-nRP			18-18-18				
Parameter	Symbol		Min	Max			
Internal Read command to first data	tAA		13.50	18.00	ns	12	
Internal Read command to first data with Read DBI enabled	tAA_DBI		tAA(min) + 3nCK	tAA(max) + 3nCK	ns	12	
ACT to internal Read or Write delay time	tRCD		13.50	-	ns	12	
PRE command period	tRP		13.50	-	ns	12	
ACT to PRE command period	tRAS		32	9 x tREFI	ns	12	
ACT to ACT or REF command period	tRC		45.5	-	ns	12	
	Normal	Read DBI					
CWL = 9	CL = 9	CL = 11	tCK(AVG)	1.5	1.6	ns	1,2,3,4,11
	CL = 10	CL = 12	tCK(AVG)	1.5	1.6	ns	1,2,3,11
CWL = 9,11	CL = 10	CL = 12	tCK(AVG)	Reserved		ns	4
	CL = 11	CL = 13	tCK(AVG)	1.25	<1.5	ns	1,2,3,4,9
	CL = 12	CL = 14	tCK(AVG)	1.25	<1.5	ns	1,2,3,9
CWL = 10,12	CL = 12	CL = 14	tCK(AVG)	Reserved		ns	4
	CL = 13	CL = 15	tCK(AVG)	1.071	<1.25	ns	1,2,3,4,9
	CL = 14	CL = 16	tCK(AVG)	1.071	<1.25	ns	1,2,3,9
CWL = 11,14	CL = 14	CL = 17	tCK(AVG)	Reserved		ns	4
	CL = 15	CL = 18	tCK(AVG)	0.937	<1.071	ns	1,2,3,4,9
	CL = 16	CL = 19	tCK(AVG)	0.937	<1.071	ns	1,2,3,9
CWL = 12,16	CL = 15	CL = 18	tCK(AVG)	Reserved		ns	4
	CL = 16	CL = 19	tCK(AVG)	Reserved		ns	1,2,3,4,9
	CL = 17	CL = 20	tCK(AVG)	0.833	<0.937	ns	1,2,3,4,9
	CL = 18	CL = 21	tCK(AVG)	0.833	<0.937	ns	1,2,3,9
CWL = 14,18	CL = 17	CL = 20	tCK(AVG)	Reserved		ns	1,2,3,4
	CL = 18	CL = 21	tCK(AVG)	0.75	<0.833	ns	1,2,3,4
	CL = 19	CL = 22	tCK(AVG)	0.75	<0.833	ns	1,2,3,4
	CL = 20	CL = 23	tCK(AVG)	0.75	<0.833	ns	1,2,3
Supported CL Settings			9,10,11,12,13,14,15,16,17,18,19,20		nCK	13	
Supported CL Settings with Read DBI			11,12,13,14,15,16,18,19,20,21,22,23		nCK		
Supported CWL Settings			9,10,11,12,14,16,18		nCK		

Speed Bin Table Note

Absolute Specifications

- $VDDQ = VDD = 1.20V \pm 0.06 V$
 - $VPP = 2.5V$ (2.375V min, 2.75V max)
 - The values defined with above-mentioned table are DLL ON case.
 - DDR4-1600, 1866, 2133 and 2400 Speed Bin Tables are valid only when Gear Down Mode is disabled.
- 1 The CL setting and CWL setting result in $tCK(ave)$.MIN and $tCK(ave)$.MAX requirements. When making a selection of $tCK(ave)$, both need to be fulfilled: Requirements from CL setting as well as requirements from CWL setting.
 - 2 $tCK(ave)$.MIN limits: Since CAS Latency is not purely analog - data and strobe output are synchronized by the DLL-all possible intermediate frequencies may not be guaranteed. CL in clock cycle is calculated from tAA following rounding algorithm defined in [Section 9.5](#).
 - 3 $tCK(ave)$.MAX limits: Calculate $tCK(ave) = tAA.MAX / CL$ SELECTED and round the resulting $tCK(ave)$ down to the next valid speed bin (i.e. 1.5ns or 1.25ns or 1.071 ns or 0.937 ns or 0.833 ns). This result is $tCK(ave)$.MAX corresponding to CL SELECTED.
 - 4 'Reserved'settings are not allowed. User must program a different value.
 - 5 'Optional' settings allow certain devices in the industry to support this setting, however, it is not a mandatory feature. Refer to supplier's data sheet and/or the DIMM SPD information if and how this setting is supported.
 - 6 Any DDR4-1866 speed bin also supports functional operation at lower frequencies as shown in the corresponding table which are not subject to Production Tests but verified by Design/Characterization.
 - 7 Any DDR4-2133 speed bin also supports functional operation at lower frequencies as shown in the corresponding table which are not subject to Production Tests but verified by Design/Characterization.
 - 8 Any DDR4-2400 speed bin also supports functional operation at lower frequencies as shown in the corresponding table which are not subject to Production Tests but verified by Design/Characterization.

- 9 Any DDR4-2666 speed bin also supports functional operation at lower frequencies as shown in the corresponding table which are not subject to Production Tests but verified by Design/Characterization.
- 10 Any DDR4-3200 speed bin also supports functional operation at lower frequencies as shown in the corresponding table which are not subject to Production Tests but verified by Design/Characterization.
- 11 DDR4-1600 AC timing apply if DRAM operates at lower than 1600 MT/s data rate.
- 12 Parameters apply from tCK(avg)min to tCK(avg)max at all standard JEDEC clock period values as stated in the Speed Bin Tables.
- 13 CL number in parentheses, it means that these numbers are optional.
- 14 DDR4 SDRAM supports CL=9 as long as a system meets tAA(min).
- 15 Each speed bin lists the timing requirements that need to be supported in order for a given DRAM to be JEDEC compliant. JEDEC compliance does not require support for all speed bins within a given speed. JEDEC compliance requires meeting the parameters for a least one of the listed speed bins.

6.2 tREFI and tRFC Parameters

Table 6-2 tREFI and tRFC Parameters

Refresh Mode	Parameter	8Gb	Unit
	tREFI(base)	7.8	us
1× mode	tREFI1	-40 °C ≤ TCASE ≤ 85 °C	tREFI(base)
		85 °C < TCASE ≤ 95 °C	tREFI(base)/2
		tRFC1(min)	350
2× mode	tREFI2	-40 °C ≤ TCASE ≤ 85 °C	tREFI(base)/2
		85 °C < TCASE ≤ 95 °C	tREFI(base)/4
		tRFC2(min)	260
4× mode	tREFI4	-40 °C ≤ TCASE ≤ 85 °C	tREFI(base)/4
		85 °C < TCASE ≤ 95 °C	tREFI(base)/8
		tRFC4(min)	160

7. IDD and IDDQ Specification Parameters and Test Conditions

In this chapter, IDD, IPP and IDDQ measurement conditions such as test load and patterns are defined.

- [IDD, IPP and IDDQ Measurement Conditions on Page 64](#)
- [IDD Specifications on Page 93](#)

CXMT Privileged and Confidential

7.1 IDD, IPP and IDDQ Measurement Conditions

Figure 7-11 shows the setup and test load for IDD, IPP and IDDQ measurements.

- IDD currents (such as IDD0, IDD0A, IDD1, IDD1A, IDD2N, IDD2NA, IDD2NL, IDD2NT, IDD2P, IDD2Q, IDD3N, IDD3NA, IDD3P, IDD4R, IDD4RA, IDD4W, IDD4WA, IDD5B, IDD5F2, IDD5F4, IDD6N, IDD6E, IDD6R, IDD6A, IDD7 and IDD8) are measured as time-averaged currents with all VDD balls of the DDR4 SDRAM under test tied together. Any IPP or IDDQ current is not included in IDD currents.
- IPP currents have the same definition as IDD except that the current on the VPP supply is measured.
- IDDQ currents (such as IDDQ2NT and IDDQ4R) are measured as time-averaged currents with all VDDQ balls of the DDR4 SDRAM under test tied together. Any IDD current is not included in IDDQ currents.

Attention: IDDQ values cannot be directly used to calculate IO power of the DDR4 SDRAM. They can be used to support correlation of simulated IO power to actual IO power as outlined in Figure 7-22. In DRAM module application, IDDQ cannot be measured separately since VDD and VDDQ are using one merged-power layer in Module PCB.

For IDD, IPP and IDDQ measurements, the following definitions apply:

- “0” and “Low” is defined as $V_{IN} \leq V_{ILAC}(\max)$.
- “1” and “High” is defined as $V_{IN} \geq V_{IHAC}(\min)$.
- “MID-LEVEL” is defined as inputs are $V_{REF} = V_{DD} / 2$.
- Basic IDD, IPP and IDDQ Measurement Conditions are described in Table 7-2.
- Detailed IDD, IPP and IDDQ Measurement-Loop Patterns are described Table 7-33.
- IDD Measurements are done after properly initializing the DDR4 SDRAM. This includes but is not limited to setting

$R_{ON} = R_{ZQ}/7$ (34 Ohm in MR1);

$R_{TT_NOM} = R_{ZQ}/6$ (40 Ohm in MR1);

RTT_WR = RZQ/2 (120 Ohm in MR2);

RTT_PARK = Disable;

Qoff = 0 (Output Buffer enabled) in MR1;

TDQS_t disabled in MR1; CRC disabled in MR2;

CA parity feature disabled in MR5;

Gear down mode disabled in MR3

Read/Write DBI disabled in MR5;

DM disabled in MR5

- Attention: The IDD, IPP and IDDQ Measurement-Loop Patterns need to be executed at least one time before actual IDD or IDDQ measurement is started.
- Define D = {CS_n, ACT_n, RAS_n, CAS_n, WE_n} := {High, Low, Low, Low, Low}
- Define D# = {CS_n, ACT_n, RAS_n, CAS_n, WE_n} := {High, High, High, High, High}; apply invert of BG/BA changes when directed above.

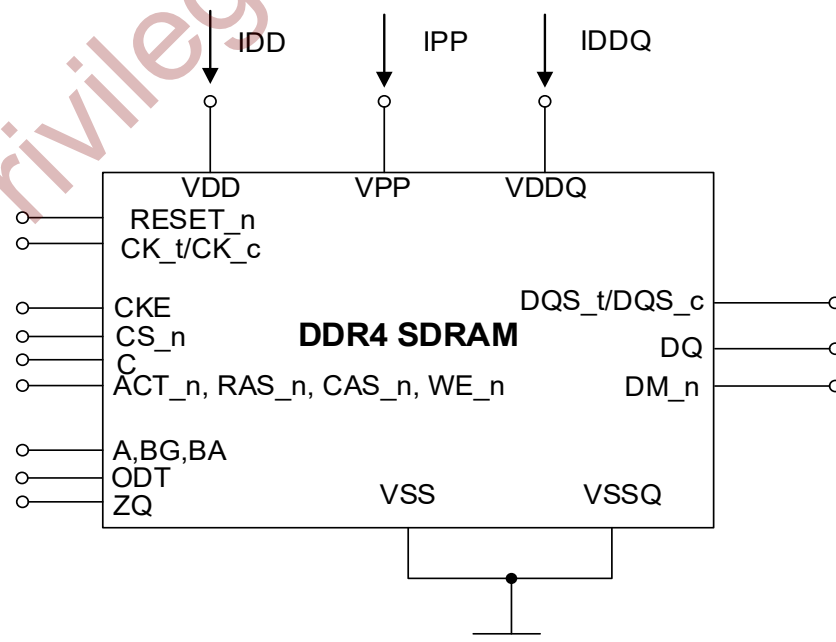

Figure 7-1 Measurement Setup and Test Load for IDD, IPP and IDDQ Measurements

Note:

DIMM level Output test load condition may be different from above

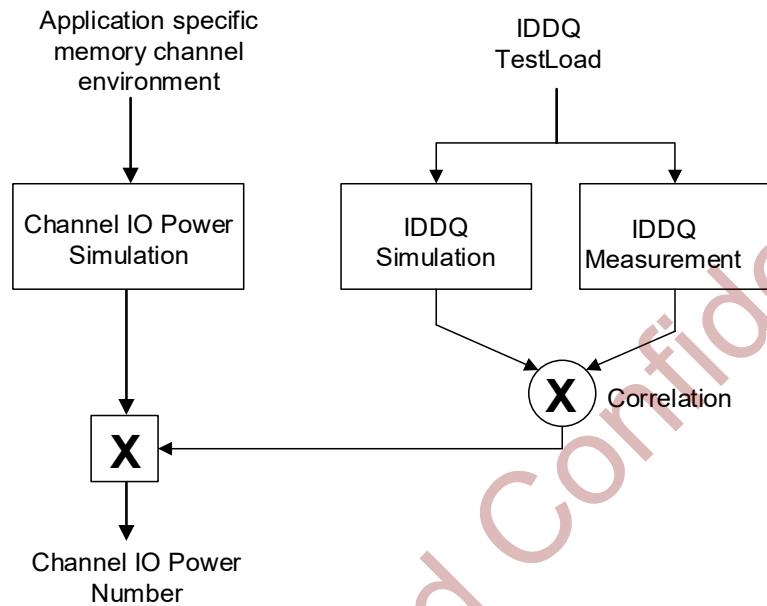

Figure 7-2 Correlation from Simulated Channel IO Power to Actual Channel IO Power Supported by IDDQ Measurement.

Table 7-1 Timings used for IDD, IPP and IDDQ Measurement-Loop Patterns

Symbol	DDR4-1600			DDR4-1866			DDR4-2133			DDR4-2400				Unit	
	10-10-10	11-11-11	12-12-12	12-12-12	13-13-13	14-14-14	14-14-14	15-15-15	16-16-16	15-15-15	16-16-16	17-17-17	18-18-18		
tCK	1.25			1.071			0.937			0.833				ns	
CL	10	11	12	12	13	14	14	15	16	15	16	17	18	nCK	
CWL	9	11	11	10	12	12	11	14	14	12	16	16	16	nCK	
nRCD	10	11	12	12	13	14	14	15	16	15	16	17	18	nCK	
nRC	38	39	40	44	45	46	50	51	52	54	55	56	57	nCK	
nRAS	28			32			36			39				nCK	
nRP	10	11	12	12	13	14	14	15	16	15	16	17	18	nCK	
nFAW	x4	16			16			16			16				nCK
	x8	20			22			23			26				nCK
	x16	28			28			32			36				nCK
nRRDS	x4	4			4			4			4				nCK
	x8	4			4			4			4				nCK
	x16	5			6			6			7				nCK
nRRDL	x4	5			5			6			6				nCK
	x8	5			5			6			6				nCK
	x16	6			6			7			8				nCK
tCCD_S	4			4			4			4				nCK	
tCCD_L	5			5			6			6				nCK	
tWTR_S	2			3			3			3				nCK	
tWTR_L	6			7			8			9				nCK	

Symbol	DDR4-1600			DDR4-1866			DDR4-2133			DDR4-2400				Unit
	10-10-10	11-11-11	12-12-12	12-12-12	13-13-13	14-14-14	14-14-14	15-15-15	16-16-16	15-15-15	16-16-16	17-17-17	18-18-18	
nRFC 2Gb	128			150			171			193				nCK
nRFC 4Gb	208			243			278			313				nCK
nRFC 8Gb	280			327			374			421				nCK
nRFC 16Gb	440			514			587			661				nCK

Symbol	DDR4-2666				DDR4-2933				DDR4-3200			Unit
	17-17-17	18-18-18	19-19-19	20-20-20	19-19-19	20-20-20	21-21-21	22-22-22	20-20-20	22-22-22	24-24-24	
tCK	0.75				0.682				0.625			ns
CL	17	18	19	20	19	20	21	22	20	22	24	nCK
CWL	16	16	18	18	18	18	20	20	18	20	20	nCK
nRCD	17	18	19	20	19	20	21	22	20	22	24	nCK
nRC	60	61	62	63	66	67	68	69	72	74	76	nCK
nRAS	43				47				52			nCK
nRP	17	18	19	20	19	20	21	22	20	22	24	nCK
nFAW	x4	16			16				16			nCK
	x8	28			31				34			nCK
	x16	40			44				48			nCK
nRRDS	x4	4			4				4			nCK
	x8	4			4				4			nCK
	x16	8			8				9			nCK
nRRDL	x4	7			8				8			nCK
	x8	7			8				8			nCK
	x16	9			10				11			nCK
tCCD_S	4			4				4			nCK	
tCCD_L	7			8				8			nCK	
tWTR_S	4			4				4			nCK	
tWTR_L	10			11				12			nCK	
nRFC 2Gb	214			235				256			nCK	
nRFC 4Gb	347			382				416			nCK	
nRFC 8Gb	467			514				560			nCK	
nRFC 16Gb	734			807				880			nCK	

Table 7-2 Basic IDD, IPP and IDDQ Measurement Conditions

Symbol	Description
IDD0	Operating One Bank Active-Precharge Current (AL=0) CKE: High; External clock: On; tCK, nRC, nRAS, nRCD, CL BL: 8 ¹ ; AL: 0; CS_n: High between ACT and PRE; Command, Address, Bank Group Address, Bank Address Inputs: partially toggling according to Table 7-3; Data IO: VDDQ; DM_n: stable at 1; Bank Activity: Cycling with one bank active at a time: 0,0,1,1,2,2,... (see Table 7-3); Output Buffer and RTT: Enabled in Mode Registers ² ; ODT Signal: stable at 0; Pattern Details: see Table 7-3.
IDD0A	Operating One Bank Active-Precharge Current (AL=CL-1) AL = CL-1, Other conditions: see IDD0
IPP0	Operating One Bank Active-Precharge IPP Current Same condition with IDD0
IDD1	Operating One Bank Active-Read-Precharge Current (AL=0) CKE: High; External clock: On; tCK, nRC, nRAS, nRCD, CL BL: 8 ¹ ; AL: 0; CS_n: High between ACT, RD and PRE; Command, Address, Bank Group Address, Bank Address Inputs, Data IO: partially toggling according to Table 7-4 DM_n: stable at 1; Bank Activity: Cycling with one bank active at a time: 0,0,1,1,2,2,... (see Table 7-4) ; Output Buffer and RTT: Enabled in Mode Registers ² ; ODT Signal: stable at 0; Pattern Details: see Table 7-4
IDD1A	Operating One Bank Active-Read-Precharge Current (AL=CL-1) AL = CL-1, Other conditions: see IDD1
IPP1	Operating One Bank Active-Read-Precharge IPP Current Same condition with IDD1

Symbol	Description
IDD2N	Precharge Standby Current (AL=0) CKE: High; External clock: On; tCK, CL BL: 8 ¹ ; AL: 0; CS_n: stable at 1; Command, Address, Bank Group Address, Bank Address Inputs: partially toggling according to Table 7-5 Data IO: VDDQ; DM_n: stable at 1; Bank Activity: all banks closed; Output Buffer and RTT: Enabled in Mode Registers ² ; ODT Signal: stable at 0; Pattern Details: see Table 7-5
IDD2NA	Precharge Standby Current (AL=CL-1) AL = CL-1, Other conditions: see IDD2N
IPP2N	Precharge Standby IPP Current Same condition with IDD2N
IDD2NT	Precharge Standby ODT Current CKE: High; External clock: On; tCK, CL BL: 8 ¹ ; AL: 0; CS_n: stable at 1; Command, Address, Bank Group Address, Bank Address Inputs: partially toggling according to Table 7-6 Data IO: VSSQ; DM_n: stable at 1; Bank Activity: all banks closed; Output Buffer and RTT: Enabled in Mode Registers ² ; ODT Signal: toggling according to Table 7-6 Pattern Details: Table 7-6
IDDQ2NT (Optional)	Precharge Standby ODT IDDQ Current Same definition like for IDD2NT, however measuring IDDQ current instead of IDD current
IDD2NL	Precharge Standby Current with CAL enabled Same definition like for IDD2N, CAL enabled ³
IDD2NG	Precharge Standby Current with Gear Down mode enabled Same definition like for IDD2N, Gear Down mode enabled ^{3,5}
IDD2ND	Precharge Standby Current with DLL disabled Same definition like for IDD2N, DLL disabled ³

Symbol	Description
IDD2N_par	Precharge Standby Current with CA parity enabled Same definition like for IDD2N, CA parity enabled ³
IDD2P	Precharge Power-Down Current CKE: Low; External clock: On; tCK, CL BL: 8¹; AL: 0; CS_n: stable at 1; Command, Address, Bank Group Address, Bank Address Inputs: stable at 0; Data IO: VDDQ; DM_n: stable at 1; Bank Activity: all banks closed; Output Buffer and RTT: Enabled in Mode Registers²; ODT Signal: stable at 0
IPP2P	Precharge Power-Down IPP Current Same condition with IDD2P
IDD2Q	Precharge Quiet Standby Current CKE: High; External clock: On; tCK, CL BL: 8¹; AL: 0; CS_n: stable at 1; Command, Address, Bank Group Address, Bank Address Inputs: stable at 0; Data IO: VDDQ; DM_n: stable at 1; Bank Activity: all banks closed; Output Buffer and RTT: Enabled in Mode Registers²; ODT Signal: stable at 0
IDD3N	Active Standby Current CKE: High; External clock: On; tCK, CL BL: 8¹ AL: 0; CS_n: stable at 1; Command, Address, Bank Group Address, Bank Address Inputs: partially toggling according to Table 7-5 Data IO: VDDQ; DM_n: stable at 1; Bank Activity: all banks open; Output Buffer and RTT: Enabled in Mode Registers²; ODT Signal: stable at 0; Pattern Details: see Table 7-5
IDD3NA	Active Standby Current (AL=CL-1) AL = CL-1, Other conditions: see IDD3N

Symbol	Description
IPP3N	Active Standby IPP Current Same condition with IDD3N
IDD3P	Active Power-Down Current CKE: Low; External clock: On; tCK, CL BL: 8 ¹ ; AL: 0; CS_n: stable at 1; Command, Address, Bank Group Address, Bank Address Inputs: stable at 0; Data IO: VDDQ; DM_n: stable at 1; Bank Activity: all banks open; Output Buffer and RTT: Enabled in Mode Registers ² ; ODT Signal: stable at 0
IPP3P	Active Power-Down IPP Current Same condition with IDD3P
IDD4R	Operating Burst Read Current CKE: High; External clock: On; tCK, CL BL: 8 ² ; AL: 0; CS_n: High between RD; Command, Address, Bank Group Address, Bank Address Inputs: partially toggling according to Table 7-7 Data IO: seamless Read data burst with different data between one burst and the next one according to Table 7-7 DM_n: stable at 1; Bank Activity: all banks open, RD commands cycling through banks: 0,0,1,1,2,2,... (see Table 7-7) Output Buffer and RTT: Enabled in Mode Registers ² ; ODT Signal: stable at 0; Pattern Details: see Table 7-7
IDD4RA	Operating Burst Read Current (AL=CL-1) AL = CL-1, Other conditions: see IDD4R
IDD4RB	Operating Burst Read Current with Read DBI Read DBI enabled ³ , Other conditions: see IDD4R
IPP4R	Operating Burst Read IPP Current Same condition with IDD4R
IDDQ4R (Optional)	Operating Burst Read IDDQ Current Same definition like for IDD4R, however measuring IDDQ current instead of IDD current
IDDQ4RB (Optional)	Operating Burst Read IDDQ Current with Read DBI Same definition like for IDD4RB, however measuring IDDQ current instead of IDD current

Symbol	Description
IDD4W	Operating Burst Write Current CKE: High; External clock: On; tCK, CL BL: 8 ¹ ; AL: 0; CS_n: High between WR; Command, Address, Bank Group Address, Bank Address Inputs: partially toggling according to Table 7-8 ; Data IO: seamless Write data burst with different data between one burst and the next one according to Table 7-8 DM_n: stable at 1; Bank Activity: all banks open, WR commands cycling through banks: 0,0,1,1,2,2,... (Table 7-8); Output Buffer and RTT: Enabled in Mode Registers ² ; ODT Signal: stable at High; Pattern Details: see Table 7-8
IDD4WA	Operating Burst Write Current (AL=CL-1) AL = CL-1, Other conditions: see IDD4W
IDD4WB	Operating Burst Write Current with Write DBI Write DBI enabled ³ , Other conditions: see IDD4W
IDD4WC	Operating Burst Write Current with Write CRC Write CRC enabled ³ , Other conditions: see IDD4W
IDD4W_par	Operating Burst Write Current with CA Parity CA Parity enabled ³ , Other conditions: see IDD4W
IPP4W	Operating Burst Write IPP Current Same condition with IDD4W
IDD5B	Burst Refresh Current (1X REF) CKE: High; External clock: On; tCK, CL, nRFC BL: 8 ¹ ; AL: 0; CS_n: High between REF; Command, Address, Bank Group Address, Bank Address Inputs: partially toggling according to Table 7-10 Data IO: VDDQ; DM_n: stable at 1; Bank Activity: REF command every nRFC (see Table 7-10); Output Buffer and RTT: Enabled in Mode Registers ² ; ODT Signal: stable at 0; Pattern Details: see Table 7-10
IPP5B	Burst Refresh Write IPP Current (1X REF) Same condition with IDD5B

Symbol	Description
IDD5F2	Burst Refresh Current (2X REF) tRFC=tRFC_x2, Other conditions: see IDD5B
IPP5F2	Burst Refresh Write IPP Current (2X REF) Same condition with IDD5F2
IDD5F4	Burst Refresh Current (4X REF) tRFC=tRFC_x4, Other conditions: see IDD5B
IPP5F4	Burst Refresh Write IPP Current (4X REF) Same condition with IDD5F4
IDD6N	Self Refresh Current: Normal Temperature Range TCASE: 0 - 85°C; Low Power Array Self Refresh (LP ASR) : Normal ⁴ ; CKE: Low; External clock: Off; CK_t and CK_c#: Low; CL BL: 8 ¹ ; AL: 0; CS_n#, Command, Address, Bank Group Address, Bank Address, Data IO: High; DM_n: stable at 1; Bank Activity: Self-Refresh operation; Output Buffer and RTT: Enabled in Mode Registers ² ; ODT Signal: MID-LEVEL
IPP6N	Self Refresh IPP Current: Normal Temperature Range Same condition with IDD6N
IDD6E	Self-Refresh Current: Extended Temperature Range) TCASE: 0 - 95°C; Low Power Array Self Refresh (LP ASR) : Extended ⁴ ; CKE: Low; External clock: Off; CK_t and CK_c: Low; CL BL: 8 ¹ ; AL: 0; CS_n, Command, Address, Bank Group Address, Bank Address, Data IO: High; DM_n: stable at 1; Bank Activity: Extended Temperature Self-Refresh operation; Output Buffer and RTT: Enabled in Mode Registers ² ; ODT Signal: MID-LEVEL
IPP6E	Self Refresh IPP Current: Extended Temperature Range Same condition with IDD6E

Symbol	Description
IDD6R	Self-Refresh Current: Reduced Temperature Range T_{CASE}: 0 - TBD (~35-45)°C; Low Power Array Self Refresh (LP ASR) : Reduced⁴; CKE: Low; External clock: Off; CK_t and CK_c#: Low; CL BL: 8¹; AL: 0; CS_n#, Command, Address, Bank Group Address, Bank Address, Data IO: High; DM_n:stable at 1; Bank Activity: Extended Temperature Self-Refresh operation; Output Buffer and RTT: Enabled in Mode Registers²; ODT Signal: MID-LEVEL
IPP6R	Self Refresh IPP Current: Reduced Temperature Range Same condition with IDD6R
IDD6A	Auto Self-Refresh Current T_{CASE}: 0 - 95°C; Low Power Array Self Refresh (LP ASR) : Auto⁴; Partial Array Self-Refresh (PASR): Full Array; CKE: Low; External clock: Off; CK_t and CK_c#: Low; CL BL: 8¹; AL: 0; CS_n#, Command, Address, Bank Group Address, Bank Address, Data IO: High; DM_n:stable at 1; Bank Activity: Auto Self-Refresh operation; Output Buffer and RTT: Enabled in Mode Registers²; ODT Signal: MID-LEVEL
IPP6A	Auto Self-Refresh IPP Current Same condition with IDD6A

Symbol	Description
IDD7	<p>Operating Bank Interleave Read Current CKE: High; External clock: On; tCK, nRC, nRAS, nRCD, nRRD, nFAW, CL BL: 8¹; AL: CL-1; CS_n: High between ACT and RDA; Command, Address, Bank Group Address, Bank Address Inputs: partially toggling according to Table 7-1111; Data IO: Read data bursts with different data between one burst and the next one according to Table 7-11 DM_n: stable at 1; Bank Activity: two times interleaved cycling through banks (0, 1, ...7) with different addressing, see Table 7-11 Output Buffer and RTT: Enabled in Mode Registers²; ODT Signal: stable at 0; Pattern Details: see Table 7-11</p>
IPP7	<p>Operating Bank Interleave Read IPP Current Same condition with IDD7</p>
IDD8	<p>Maximum Power Down Current TBD</p>
IPP8	<p>Maximum Power Down IPP Current Same condition with IDD8</p>

7.1.1 IDD0, IDD0A and IPP0 Measurement-Loop Pattern

 Table 7-3 IDD0, IDD0A and IPP0 Measurement-Loop Pattern¹

CK_t / CK_c	CKE	Sub-Loop	Cycle Number	Command	CS_n	ACT_n	RAS_n/ A16	CAS_n/ A15	WE_n/ A14	ODT	C[2:0] ³	BG[1:0] ²	BA[1:0]	A12/BC_n	A[17,13,11]	A[10]/AP	A[9:7]	A[6:3]	A[2:0]	Data ⁴			
loggling	Static High	0	0	ACT	0	0	0	0	0	0	0	0	0	0	0	0	0	0	0	0			
			1,2	D, D	1	0	0	0	0	0	0	0	0	0	0	0	0	0	0	0	0		
			3,4	D_#,D_#	1	1	1	1	1	1	0	0	3 ²	3	0	0	0	0	7	F	0		
			...	repeat pattern 1...4 until nRAS - 1, truncate if necessary																			
			nRAS	PRE	0	1	0	1	0	0	0	0	0	0	0	0	0	0	0	0	0	0	
			...	repeat pattern 1...4 until nRC - 1, truncate if necessary																			
			1	1*nRC	repeat Sub-Loop 0, use BG[1:0] ² = 1, BA[1:0] = 1 instead																		
			2	2*nRC	repeat Sub-Loop 0, use BG[1:0] ² = 0, BA[1:0] = 2 instead																		
			3	3*nRC	repeat Sub-Loop 0, use BG[1:0] ² = 1, BA[1:0] = 3 instead																		
			4	4*nRC	repeat Sub-Loop 0, use BG[1:0] ² = 0, BA[1:0] = 1 instead																		
			5	5*nRC	repeat Sub-Loop 0, use BG[1:0] ² = 1, BA[1:0] = 2 instead																		
			6	6*nRC	repeat Sub-Loop 0, use BG[1:0] ² = 0, BA[1:0] = 3 instead																		
			7	7*nRC	repeat Sub-Loop 0, use BG[1:0] ² = 1, BA[1:0] = 0 instead																		
			8	8*nRC	repeat Sub-Loop 0, use BG[1:0] ² = 2, BA[1:0] = 0 instead																		
			9	9*nRC	repeat Sub-Loop 0, use BG[1:0] ² = 3, BA[1:0] = 1 instead																		
	10	10*nRC	repeat Sub-Loop 0, use BG[1:0] ² = 2, BA[1:0] = 2 instead																				
	11	11*nRC	repeat Sub-Loop 0, use BG[1:0] ² = 3, BA[1:0] = 3 instead																				
	12	12*nRC	repeat Sub-Loop 0, use BG[1:0] ² = 2, BA[1:0] = 1 instead																				
	13	13*nRC	repeat Sub-Loop 0, use BG[1:0] ² = 3, BA[1:0] = 2 instead																				
	14	14*nRC	repeat Sub-Loop 0, use BG[1:0] ² = 2, BA[1:0] = 3 instead																				
	15	15*nRC	repeat Sub-Loop 0, use BG[1:0] ² = 3, BA[1:0] = 0 instead																				

For x4 and x8 only

Note:

- 1 DQS_t, DQS_c are VDDQ.
- 2 BG1 is Don't Care for x16 device
- 3 C[2:0] are used only for 3DS device
- 4 DQ signals are VDDQ.

CXMT Privileged and Confidential

7.1.2 IDD1, IDD1A and IPP1 Measurement-Loop Pattern

Table 7-4 IDD1, IDD1A and IPP1 Measurement-Loop Pattern¹

CK_t/CK_c	CKE	Sub-Loop	Cycle Number	Command	CS_n	ACT_n	RAS_n/ A16	CAS_n/ A15	WE_n/ A14	ODT	C[2:0] ³	BG[1:0] ²	BA[1:0]	A12/ BC_n	A[17,13,11]	A[10]/AP	A[9:7]	A[6:3]	A[2:0]	Data ⁴			
Toggling	Static High	0	0	ACT	0	0	0	0	0	0	0	0	0	0	0	0	0	0	0	0			
			1,2	D, D	1	0	0	0	0	0	0	0	0	0	0	0	0	0	0	0	0	0	
			3,4	D_#,D_#	1	1	1	1	1	1	0	0	0	3 ^b	3	0	0	0	0	7	F	0	
			...	repeat pattern 1...4 until nRCD - AL - 1, truncate if necessary																			
			nRCD -AL	RD	0	1	1	0	1	0	0	0	0	0	0	0	0	0	0	0	0	0	D0=00, D1=FF D2=FF, D3=00 D4=FF, D5=00 D6=00, D7=FF
			...	repeat pattern 1...4 until nRAS - 1, truncate if necessary																			
			nRAS	PRE	0	1	0	1	0	0	0	0	0	0	0	0	0	0	0	0	0	0	
			...	repeat pattern nRC + 1...4 until 1*nRC + nRAS - 1, truncate if necessary																			
		1	1*nRC + 0	ACT	0	0	0	1	1	0	0	0	1	1	0	0	0	0	0	0	0		
			1*nRC + 1, 2	D, D	1	0	0	0	0	0	0	0	0	0	0	0	0	0	0	0	0		
			1*nRC + 3, 4	D_#,D_#	1	1	1	1	1	1	0	0	0	3 ^b	3	0	0	0	0	7	F	0	
			...	repeat pattern nRC + 1...4 until 1*nRC + nRAS - 1, truncate if necessary																			
			1*nRC + nRCD - AL	RD	0	1	1	0	1	0	0	0	0	1	1	0	0	0	0	0	0	0	D0=FF, D1=00 D2=00, D3=FF D4=00, D5=FF D6=FF, D7=00
			...	repeat pattern 1...4 until nRAS - 1, truncate if necessary																			
			1*nRC + nRAS	PRE	0	1	0	1	0	0	0	0	0	0	0	0	0	0	0	0	0	0	
			...	repeat nRC + 1...4 until 2*nRC - 1, truncate if necessary																			
		2	2*Nrc	repeat Sub-Loop 0, use BG[1:0] ² = 0, BA[1:0] = 2 instead																			
		3	3*nRC	repeat Sub-Loop 1, use BG[1:0] ² = 1, BA[1:0] = 3 instead																			
		4	4*Nrc	repeat Sub-Loop 0, use BG[1:0] ² = 0, BA[1:0] = 1 instead																			
		5	5*Nrc	repeat Sub-Loop 1, use BG[1:0] ² = 1, BA[1:0] = 2 instead																			

CK_t/CK_c	CKE	Sub-Loop	Cycle Number	Command	CS_n	ACT_n	RAS_n/ A16	CAS_n/ A15	WE_n/ A14	ODT	C[2:0] ³	BG[1:0] ²	BA[1:0]	A12/ BC_n	A[17,13,11]	A[10]/AP	A[9:7]	A[6:3]	A[2:0]	Data ⁴	
		6	6*Nrc	repeat Sub-Loop 0, use BG[1:0] ² = 0, BA[1:0] = 3 instead																	
		8	7*Nrc	repeat Sub-Loop 1, use BG[1:0] ² = 1, BA[1:0] = 0 instead																	
		9	9*Nrc	repeat Sub-Loop 1, use BG[1:0] ² = 2, BA[1:0] = 0 instead																	
		10	10*Nrc	repeat Sub-Loop 0, use BG[1:0] ² = 3, BA[1:0] = 1 instead																	
		11	11*Nrc	repeat Sub-Loop 1, use BG[1:0] ² = 2, BA[1:0] = 2 instead																	
		12	12*Nrc	repeat Sub-Loop 0, use BG[1:0] ² = 3, BA[1:0] = 3 instead																	
		13	13*Nrc	repeat Sub-Loop 1, use BG[1:0] ² = 2, BA[1:0] = 1 instead																	
		14	14*Nrc	repeat Sub-Loop 0, use BG[1:0] ² = 3, BA[1:0] = 2 instead																	
		15	15*Nrc	repeat Sub-Loop 1, use BG[1:0] ² = 2, BA[1:0] = 3 instead																	
		16	16*Nrc	repeat Sub-Loop 0, use BG[1:0] ² = 3, BA[1:0] = 0 instead																	

For x4 and x8 only

Note:

- 1 DQS_t, DQS_c are used according to RD Commands, otherwise VDDQ.
- 2 BG1 is Don't Care for x16 device
- 3 C[2:0] are used only for 3DS device
- 4 Burst Sequence driven on each DQ signal by Read Command. Outside burst operation, DQ signals are VDDQ.

7.1.3 IDD2N, IDD2NA, IDD2NL, IDD2NG, IDD2ND, IDD2N_par, IPP2,IDD3N, IDD3NA and IDD3P Measurement-Loop Pattern

Table 7-5 IDD2N, IDD2NA, IDD2NL, IDD2NG, IDD2ND, IDD2N_par, IPP2,IDD3N, IDD3NA and IDD3P Measurement-Loop Pattern¹

CK_t/CK_c	CKE	Sub-Loop	Cycle Number	Command	CS_n	ACT_n	RAS_n/A16	CAS_n/A15	WE_n/A14	ODT	C[2:0] ³	BG[1:0] ²	BA[1:0]	A12/BC_n	A[17,13,11]	A[10]/AP	A[9:7]	A[6:3]	A[2:0]	Data ⁴		
tooggling	Static High		0	D, D	1	0	0	0	0	0	0	0	0	0	0	0	0	0	0	0		
			1	D, D	1	0	0	0	0	0	0	0	0	0	0	0	0	0	0	0	0	
			2	D_#,D_#	1	1	1	1	1	1	0	0	3 ²	3	0	0	0	0	7	F	0	0
			3	D_#,D_#	1	1	1	1	1	1	0	0	3 ²	3	0	0	0	0	7	F	0	0
			1	4-7	repeat Sub-Loop 0, use BG[1:0] ² = 1, BA[1:0] = 1 instead																	
			2	8-11	repeat Sub-Loop 0, use BG[1:0] ² = 0, BA[1:0] = 2 instead																	
			3	12-15	repeat Sub-Loop 0, use BG[1:0] ² = 1, BA[1:0] = 3 instead																	
			4	16-19	repeat Sub-Loop 0, use BG[1:0] ² = 0, BA[1:0] = 1 instead																	
			5	20-23	repeat Sub-Loop 0, use BG[1:0] ² = 1, BA[1:0] = 2 instead																	
			6	24-27	repeat Sub-Loop 0, use BG[1:0] ² = 0, BA[1:0] = 3 instead																	
			7	28-31	repeat Sub-Loop 0, use BG[1:0] ² = 1, BA[1:0] = 0 instead																	
			8	32-35	repeat Sub-Loop 0, use BG[1:0] ² = 2, BA[1:0] = 0 instead																	
			9	36-39	repeat Sub-Loop 0, use BG[1:0] ² = 3, BA[1:0] = 1 instead																	
			10	40-43	repeat Sub-Loop 0, use BG[1:0] ² = 2, BA[1:0] = 2 instead																	
			11	44-47	repeat Sub-Loop 0, use BG[1:0] ² = 3, BA[1:0] = 3 instead																	
	12	48-51	repeat Sub-Loop 0, use BG[1:0] ² = 2, BA[1:0] = 1 instead																			
	13	52-55	repeat Sub-Loop 0, use BG[1:0] ² = 3, BA[1:0] = 2 instead																			
	14	56-59	repeat Sub-Loop 0, use BG[1:0] ² = 2, BA[1:0] = 3 instead																			
	15	60-63	repeat Sub-Loop 0, use BG[1:0] ² = 3, BA[1:0] = 0 instead																			

Note:

- 1 DQS_t, DQS_c are VDDQ.
- 2 BG1 is Don't Care for x16 device
- 3 C[2:0] are used only for 3DS device
- 4 DQ signals are VDDQ.

CXMT Privileged and Confidential

7.1.4 IDD2NT and IDDQ2NT Measurement-Loop Pattern

 Table 7-6 IDD2NT and IDDQ2NT Measurement-Loop Pattern¹

CK_t / CK_c	CKE	Sub-Loop	Cycle Number	Command	CS_n	ACT_n	RAS_n / A16	CAS_n / A15	WE_n / A14	ODT	C[2:0] ³	BG[1:0] ²	BA[1:0]	A12/BC_n	A[17,13,11]	A[10]/AP	A[9:7]	A[6:3]	A[2:0]	Data ⁴		
Toggling	Static High	0	0	D, D	1	0	0	0	0	0	0	0	0	0	0	0	0	0	0	0		
			1	D, D	1	0	0	0	0	0	0	0	0	0	0	0	0	0	0	0	0	
			2	D_#,D_#	1	1	1	1	1	1	0	0	0	3 ²	3	0	0	0	7	F	0	
			3	D_#,D_#	1	1	1	1	1	1	0	0	0	3 ²	3	0	0	0	7	F	0	
		1	4-7	repeat Sub-Loop 0, but ODT = 1 and BG[1:0] ² = 1, BA[1:0] = 1 instead																		
		2	8-11	repeat Sub-Loop 0, but ODT = 0 and BG[1:0] ² = 0, BA[1:0] = 2 instead																		
		3	12-15	repeat Sub-Loop 0, but ODT = 1 and BG[1:0] ² = 1, BA[1:0] = 3 instead																		
		4	16-19	repeat Sub-Loop 0, but ODT = 0 and BG[1:0] ² = 0, BA[1:0] = 1 instead																		
		5	20-23	repeat Sub-Loop 0, but ODT = 1 and BG[1:0] ² = 1, BA[1:0] = 2 instead																		
		6	24-27	repeat Sub-Loop 0, but ODT = 0 and BG[1:0] ² = 0, BA[1:0] = 3 instead																		
		7	28-31	repeat Sub-Loop 0, but ODT = 1 and BG[1:0] ² = 1, BA[1:0] = 0 instead																		
		8	32-35	repeat Sub-Loop 0, but ODT = 0 and BG[1:0] ² = 2, BA[1:0] = 0 instead																		
		9	36-39	repeat Sub-Loop 0, but ODT = 1 and BG[1:0] ² = 3, BA[1:0] = 1 instead																		
		10	40-43	repeat Sub-Loop 0, but ODT = 0 and BG[1:0] ² = 2, BA[1:0] = 2 instead																		
		11	44-47	repeat Sub-Loop 0, but ODT = 1 and BG[1:0] ² = 3, BA[1:0] = 3 instead																		
12	48-51	repeat Sub-Loop 0, but ODT = 0 and BG[1:0] ² = 2, BA[1:0] = 1 instead																				
13	52-55	repeat Sub-Loop 0, but ODT = 1 and BG[1:0] ² = 3, BA[1:0] = 2 instead																				
14	56-59	repeat Sub-Loop 0, but ODT = 0 and BG[1:0] ² = 2, BA[1:0] = 3 instead																				
15	60-63	repeat Sub-Loop 0, but ODT = 1 and BG[1:0] ² = 3, BA[1:0] = 0 instead																				

For x4 and x8 only

Note:

- 1 DQS_t, DQS_c are VDDQ.
- 2 BG1 is Don't Care for x16 device
- 3 C[2:0] are used only for 3DS device
- 4 DQ signals are VDDQ

CXMT Privileged and Confidential

7.1.5 IDD4R, IDDR4RA, IDD4RB and IDDQ4R Measurement-Loop Pattern¹

Table 7-7 IDD4R, IDDR4RA, IDD4RB and IDDQ4R Measurement-Loop Pattern¹

CK_t / CK_c	CKE	Sub-Loop	Cycle Number	Command	CS_n	ACT_n	RAS_n / A16	CAS_n / A15	WE_n / A14	ODT	C [2:0] ²	BG [1:0] ²	BA [1:0]	A12 /BC_n	A[17,13,11]	A[10] /AP	A [9:7]	A [6:3]	A [2:0]	Data ⁴		
Toggling	Static High	0	0	RD	0	1	1	0	1	0	0	0	0	0	0	0	0	0	0	D0=00, D1=FF D2=FF, D3=00 D4=FF, D5=00 D6=00, D7=FF		
			1	D	1	0	0	0	0	0	0	0	0	0	0	0	0	0	0	0	-	
			2, 3	D_#,D_#	1	1	1	1	1	1	0	0	3 ²	3	0	0	0	0	7	F	0	-
		1	4	RD	0	1	1	0	1	0	1	0	0	1	1	0	0	0	7	F	0	D0=FF, D1=00 D2=00, D3=FF D4=00, D5=FF D6=FF, D7=00
			5	D	1	0	0	0	0	0	0	0	0	0	0	0	0	0	0	0	0	-
			6, 7	D_#,D_#	1	1	1	1	1	1	0	0	3 ²	3	0	0	0	0	7	F	0	-
		2	8-11	repeat Sub-Loop 0, use BG[1:0] ² = 0, BA[1:0] = 2 instead																		
		3	12-15	repeat Sub-Loop 1, use BG[1:0] ² = 1, BA[1:0] = 3 instead																		
		4	16-19	repeat Sub-Loop 0, use BG[1:0] ² = 0, BA[1:0] = 1 instead																		
		5	20-23	repeat Sub-Loop 1, use BG[1:0] ² = 1, BA[1:0] = 2 instead																		
		6	24-27	repeat Sub-Loop 0, use BG[1:0] ² = 0, BA[1:0] = 3 instead																		
		7	28-31	repeat Sub-Loop 1, use BG[1:0] ² = 1, BA[1:0] = 0 instead																		
		8	32-35	repeat Sub-Loop 0, use BG[1:0] ² = 2, BA[1:0] = 0 instead																		
		9	36-39	repeat Sub-Loop 1, use BG[1:0] ² = 3, BA[1:0] = 1 instead																		
		10	40-43	repeat Sub-Loop 0, use BG[1:0] ² = 2, BA[1:0] = 2 instead																		
11	44-47	repeat Sub-Loop 1, use BG[1:0] ² = 3, BA[1:0] = 3 instead																				
12	48-51	repeat Sub-Loop 0, use BG[1:0] ² = 2, BA[1:0] = 1 instead																				
13	52-55	repeat Sub-Loop 1, use BG[1:0] ² = 3, BA[1:0] = 2 instead																				
14	56-59	repeat Sub-Loop 0, use BG[1:0] ² = 2, BA[1:0] = 3 instead																				
15	60-63	repeat Sub-Loop 1, use BG[1:0] ² = 3, BA[1:0] = 0 instead																				

Note:

- 1 DQS_t, DQS_c are used according to RD Commands, otherwise VDDQ.
- 2 BG1 is Don't Care for x16 device
- 3 C[2:0] are used only for 3DS device
- 4 Burst Sequence driven on each DQ signal by Read Command

CXMT Privileged and Confidential

7.1.6 IDD4W, IDD4WA, IDD4WB and IDD4W_par Measurement-Loop Pattern

Table 7-8 IDD4W, IDD4WA, IDD4WB and IDD4W_par Measurement-Loop Pattern¹

CK_t / CK_c	CKE	Sub-Loop	Cycle Number	Command	CS_n	ACT_n	RAS_n/ A16	CAS_n/ A15	WE_n/ A14	ODT	C [2:0] ³	BG [1:0] ²	BA [1:0]	A12 /BC_n	A[17,13, 11]	A[10] /AP	A [9:7]	A [6:3]	A [2:0]	Data ⁴		
Toggling	Static High	0	0	WR	0	1	1	0	1	0	0	0	0	0	0	0	0	0	0	D0=00, D1=FF D2=FF, D3=00 D4=FF, D5=00 D6=00, D7=FF		
			1	D	1	0	0	0	0	0	0	0	0	0	0	0	0	0	0	0		
			2, 3	D_#,D_#	1	1	1	1	1	1	0	0	3 ²	3	0	0	0	0	7	F	0	
		1	4	WR	0	1	1	0	1	0	1	0	0	1	1	0	0	0	7	F	0	D0=FF, D1=00 D2=00, D3=FF D4=00, D5=FF D6=FF, D7=00
			5	D	1	0	0	0	0	0	0	0	0	0	0	0	0	0	0	0	0	
			6, 7	D_#,D_#	1	1	1	1	1	1	0	0	3 ²	3	0	0	0	0	7	F	0	
		2	8-11	repeat Sub-Loop 0, use BG[1:0] ² = 0, BA[1:0] = 2 instead																		
		3	12-15	repeat Sub-Loop 1, use BG[1:0] ² = 1, BA[1:0] = 3 instead																		
		4	16-19	repeat Sub-Loop 0, use BG[1:0] ² = 0, BA[1:0] = 1 instead																		
		5	20-23	repeat Sub-Loop 1, use BG[1:0] ² = 1, BA[1:0] = 2 instead																		
		6	24-27	repeat Sub-Loop 0, use BG[1:0] ² = 0, BA[1:0] = 3 instead																		
		7	28-31	repeat Sub-Loop 1, use BG[1:0] ² = 1, BA[1:0] = 0 instead																		
		8	32-35	repeat Sub-Loop 0, use BG[1:0] ² = 2, BA[1:0] = 0 instead																		
		9	36-39	repeat Sub-Loop 1, use BG[1:0] ² = 3, BA[1:0] = 1 instead																		
		10	40-43	repeat Sub-Loop 0, use BG[1:0] ² = 2, BA[1:0] = 2 instead																		
11	44-47	repeat Sub-Loop 1, use BG[1:0] ² = 3, BA[1:0] = 3 instead																				
12	48-51	repeat Sub-Loop 0, use BG[1:0] ² = 2, BA[1:0] = 1 instead																				
13	52-55	repeat Sub-Loop 1, use BG[1:0] ² = 3, BA[1:0] = 2 instead																				
14	56-59	repeat Sub-Loop 0, use BG[1:0] ² = 2, BA[1:0] = 3 instead																				
15	60-63	repeat Sub-Loop 1, use BG[1:0] ² = 3, BA[1:0] = 0 instead																				
																				For x4 and x8 only		

Note:

- 1 DQS_t, DQS_c are used according to WR Commands, otherwise VDDQ.
- 2 BG1 is Don't Care for x16 device
- 3 C[2:0] are used only for 3DS device
- 4 Burst Sequence driven on each DQ signal by Write Command.

CXMT Privileged and Confidential

7.1.7 IDD4WC Measurement-Loop Pattern

Table 7-9 IDD4WC Measurement-Loop Pattern¹

CK_t / CK_c	CKE	Sub-Loop	Cycle Number	Command	CS_n	ACT_n	RAS_n/ A16	CAS_n/ A15	WE_n/ A14	ODT	C[2:0] ²	BG[1:0] ²	BA[1:0]	A12/ BC_n	A[17,13,11]	A[10]/AP	A[9:7]	A[6:3]	A[2:0]	Data ⁴		
Toggling	Static High	0	0	WR	0	1	1	0	0	1	0	0	0	0	0	0	0	0	0	0	D0=00, D1=FF D2=FF, D3=00 D4=FF, D5=00 D6=00, D7=FF D8=CRC	
			1,2	D,D	1	0	0	0	0	0	1	0	0	0	0	0	0	0	0	0	0	-
			3,4	D#,D#	1	1	1	1	1	1	1	1	0	3 ²	3	0	0	0	7	F	0	-
			5	WR	0	1	1	0	0	0	0	1	0	1	1	0	0	0	7	F	0	D0=FF, D1=00 D2=00, D3=FF D4=00, D5=FF D6=FF, D7=00 D8=CRC
			6,7	D,D	1	0	0	0	0	0	1	0	0	0	0	0	0	0	0	0	0	-
			8,9	D#,D#	1	1	1	1	1	1	1	1	0	3 ²	3	0	0	0	7	F	0	-
		2	10-14	repeat Sub-Loop 0, use BG[1:0] ² = 0, BA[1:0] = 2 instead																		
		3	15-19	repeat Sub-Loop 1, use BG[1:0] ² = 1, BA[1:0] = 3 instead																		
		4	20-24	repeat Sub-Loop 0, use BG[1:0] ² = 0, BA[1:0] = 1 instead																		
		5	25-29	repeat Sub-Loop 1, use BG[1:0] ² = 1, BA[1:0] = 2 instead																		
		6	30-34	repeat Sub-Loop 0, use BG[1:0] ² = 0, BA[1:0] = 3 instead																		
		7	35-39	repeat Sub-Loop 1, use BG[1:0] ² = 1, BA[1:0] = 0 instead																		
		8	40-44	repeat Sub-Loop 0, use BG[1:0] ² = 2, BA[1:0] = 0 instead																		
		9	45-49	repeat Sub-Loop 1, use BG[1:0] ² = 3, BA[1:0] = 1 instead																		
		10	50-54	repeat Sub-Loop 0, use BG[1:0] ² = 2, BA[1:0] = 2 instead																		
11	55-59	repeat Sub-Loop 1, use BG[1:0] ² = 3, BA[1:0] = 3 instead																				
12	60-64	repeat Sub-Loop 0, use BG[1:0] ² = 2, BA[1:0] = 1 instead																				
13	65-69	repeat Sub-Loop 1, use BG[1:0] ² = 3, BA[1:0] = 2 instead																				
14	70-74	repeat Sub-Loop 0, use BG[1:0] ² = 2, BA[1:0] = 3 instead																				
15	75-79	repeat Sub-Loop 1, use BG[1:0] ² = 3, BA[1:0] = 0 instead																				

For x4 and x8 only

Note:

- 1 DQS_t, DQS_c are VDDQ.
- 2 BG1 is Don't Care for x16 device
- 3 C[2:0] are used only for 3DS device
- 4 Burst Sequence driven on each DQ signal by Write Command

7.1.8 IDD5B Measurement-Loop Pattern

 Table 7-10 IDD5B Measurement-Loop Pattern¹

CK _t / CK _c	CKE	Sub-Loop	Cycle Number	Command	CS _n	ACT _n	RAS _n / A16	CAS _n / A15	WE _n / A14	ODT	C[2:0] ³	BG[1:0] ²	BA[1:0]	A12/BC _n	A[17,13,11]	A[10]/AP	A[9:7]	A[6:3]	A[2:0]	Data ⁴		
Toggling	Static High	0	0	REF	1	0	0	0	0	0	0	0	0	0	0	0	0	0	0	-		
		1	1	D	1	0	0	0	0	0	0	0	0	0	0	0	0	0	0	0	-	
		2	1	D	1	0	0	0	0	0	0	0	0	0	0	0	0	0	0	0	0	-
		3	1	D#,D#	1	1	1	1	1	1	0	0	3 ²	3	0	0	0	7	F	0	-	
		4	1	D#,D#	1	1	1	1	1	1	0	0	3 ²	3	0	0	0	7	F	0	-	
		4-7	repeat pattern 1...4., use BG[1:0] ² = 1, BA[1:0] = 1 instead																			
		8-11	repeat pattern 1...4., use BG[1:0] ² = 0, BA[1:0] = 2 instead																			
		12-15	repeat pattern 1...4., use BG[1:0] ² = 1, BA[1:0] = 3 instead																			
		16-19	repeat pattern 1...4., use BG[1:0] ² = 0, BA[1:0] = 1 instead																			
		20-23	repeat pattern 1...4., use BG[1:0] ² = 1, BA[1:0] = 2 instead																			
		24-27	repeat pattern 1...4., use BG[1:0] ² = 0, BA[1:0] = 3 instead																			
		28-31	repeat pattern 1...4., use BG[1:0] ² = 1, BA[1:0] = 0 instead																			
		32-35	repeat pattern 1...4., use BG[1:0] ² = 2, BA[1:0] = 0 instead																			
		36-39	repeat pattern 1...4., use BG[1:0] ² = 3, BA[1:0] = 1 instead																			
		40-43	repeat pattern 1...4., use BG[1:0] ² = 2, BA[1:0] = 2 instead																			
		44-47	repeat pattern 1...4., use BG[1:0] ² = 3, BA[1:0] = 3 instead																			
		48-51	repeat pattern 1...4., use BG[1:0] ² = 2, BA[1:0] = 1 instead																			
		52-55	repeat pattern 1...4., use BG[1:0] ² = 3, BA[1:0] = 2 instead																			
		56-59	repeat pattern 1...4., use BG[1:0] ² = 2, BA[1:0] = 3 instead																			
		60-63	repeat pattern 1...4., use BG[1:0] ² = 3, BA[1:0] = 0 instead																			
2	64 ... nRFC - 1	repeat Sub-Loop 1, Truncate, if necessary																				

For x4 and x8 only

Note:

- 1 DQS_t, DQS_c are VDDQ.
- 2 BG1 is Don't Care for x16 device
- 3 C[2:0] are used only for 3DS device
- 4 DQ signals are VDDQ.

7.1.9 IDD7 Measurement-Loop Pattern

 Table 7-11 IDD7 Measurement-Loop Pattern¹

CK_t/ CK_c	CKE	Sub-Loop	Cycle Number	Command	CS_n	ACT_n	RAS_n/ A16	CAS_n/ A15	WE_n/ A14	ODT	C[2:0] ³	BG[1:0] ²	BA[1:0]	A12/BC_n	A[17,13,11]	A[10]/AP	A[9:7]	A[6:3]	A[2:0]	Data ⁴			
Toggleing	Static High	0	0	ACT	0	0	0	0	0	0	0	0	0	0	0	0	0	0	0	-			
			1	RDA	0	1	1	0	1	0	0	0	0	0	0	0	0	1	0	0	0	D0=00, D1=FF D2=FF, D3=00 D4=FF, D5=00 D6=00, D7=FF	
			2	D	1	0	0	0	0	0	0	0	0	0	0	0	0	0	0	0	0		
			3	D#	1	1	1	1	1	1	0	0	0	3 ²	3	0	0	0	7	F	0		
			...	repeat pattern 2...3 until nRRD - 1, if nRRD > 4. Truncate if necessary																			
		1	nRRD	ACT	0	0	0	0	0	0	0	0	0	1	1	0	0	0	0	0	0		
			nRRD+1	RDA	0	1	1	0	1	0	1	0	0	1	1	0	0	1	0	0	0		D0=FF, D1=00 D2=00, D3=FF D4=00, D5=FF D6=FF, D7=00
			...	repeat pattern 2 ... 3 until 2*nRRD - 1, if nRRD > 4. Truncate if necessary																			
			2	2*nRRD	repeat Sub-Loop 0, use BG[1:0] ² = 0, BA[1:0] = 2 instead																		
			3	3*nRRD	repeat Sub-Loop 1, use BG[1:0] ² = 1, BA[1:0] = 3 instead																		
		4	4*nRRD	repeat pattern 2 ... 3 until nFAW - 1, if nFAW > 4*nRRD. Truncate if necessary																			
		5	nFAW	repeat Sub-Loop 0, use BG[1:0] ² = 0, BA[1:0] = 1 instead																			

CK _t / CK _c	CKE	Sub-Loop	Cycle Number	Command	CS _n	ACT _n	RAS _n / A16	CAS _n / A15	WE _n / A14	ODT	C[2:0] ³	BG[1:0] ²	BA[1:0]	A12/BC _n	A[17,13,11]	A[10]/AP	A[9:7]	A[6:3]	A[2:0]	Data ⁴		
		6	nFAW + nRRD	repeat Sub-Loop 1, use BG[1:0] ² = 1, BA[1:0] = 2 instead																		
		7	nFAW + 2*nRRD	repeat Sub-Loop 0, use BG[1:0] ² = 0, BA[1:0] = 3 instead																		
		8	nFAW + 3*nRRD	repeat Sub-Loop 1, use BG[1:0] ² = 1, BA[1:0] = 0 instead																		
		9	nFAW + 4*nRRD	repeat Sub-Loop 4																		
		10	2*nFAW	repeat Sub-Loop 0, use BG[1:0] ² = 2, BA[1:0] = 1 instead																	For x4 and x8 only	
		11	2nFAW + nRRD	repeat Sub-Loop 1, use BG[1:0] ² = 3, BA[1:0] = 2 instead																		
		12	2nFAW + 2*nRRD	repeat Sub-Loop 0, use BG[1:0] ² = 2, BA[1:0] = 3 instead																		
		13	2nFAW + 3*nRRD	repeat Sub-Loop 1, use BG[1:0] ² = 3, BA[1:0] = 0 instead																		
		14	2nFAW + 4*nRRD	repeat Sub-Loop 4																		
		15	3*nFAW	repeat Sub-Loop 0, use BG[1:0] ² = 2, BA[1:0] = 1 instead																		
		16	3*nFAW + nRRD	repeat Sub-Loop 1, use BG[1:0] ² = 3, BA[1:0] = 2 instead																		
		17	3*nFAW + 2*nRRD	repeat Sub-Loop 0, use BG[1:0] ² = 2, BA[1:0] = 3 instead																		
		18	3*nFAW + 3*nRRD	repeat Sub-Loop 1, use BG[1:0] ² = 3, BA[1:0] = 0 instead																		
		19	3*nFAW + 4*nRRD	repeat Sub-Loop 4																		
		20	4*nFAW	repeat pattern 2 ... 3 until nRC - 1, if nRC > 4*nFAW. Truncate if necessary																		

Note:

- 1 DQS_t, DQS_c are VDDQ.
- 2 BG1 is Don't Care for x16 device
- 3 C[2:0] are used only for 3DS device
- 4 Burst Sequence driven on each DQ signal by Read Command. Outside burst operation, DQ signals are VDDQ.

7.2 IDD Specifications

IDD and IPP values are for full operating range of voltage and temperature unless otherwise noted.

Table 7-12 IDD and IDDQ Specifications (Rev. M)

Symbol	Width	2666	Unit
IDD0	x8	91.9	mA
	x16	105.1	mA
IDD0A	x8	92.6	mA
	x16	105.9	mA
IDD1	x8	104.8	mA
	x16	126.8	mA
IDD1A	x8	110.9	mA
	x16	136.5	mA
IDD2N	x8	72.1	mA
	x16	98.3	mA
IDD2NA	x8	72.8	mA
	x16	101.9	mA
IDD2NT	x8	86.6	mA
	x16	121.2	mA
IDD2P	x8	54.1	mA
	x16	86.6	mA
IDD2Q	x8	66.1	mA
	x16	92.5	mA
IDD3P	x8	66.7	mA
	x16	106.8	mA
IDD3N	x8	85.9	mA
	x16	120.2	mA
IDD4R	x8	161.1	mA
	x16	225.1	mA
IDD4W	x8	188.6	mA
	x16	269.8	mA
IDD5B	x8	248.7	mA
	x16	251.3	mA
IDD6A	x8	40.3	mA
	x16	56.4	mA
IDD6E	x8	40.4	mA
	x16	56.6	mA
IDD6N	x8	31.4	mA
	x16	31.4	mA
IDD6R	x8	24.7	mA
	x16	24.7	mA
IDD7	x8	232.6	mA
	x16	383.2	mA
IDD8	x8	22.9	mA
	x16	22.9	mA
IDDQ2NT	x8	35.3	mA
	x16	150.8	mA

Note:

- 1 Maximum limits are specified
- 2 Users should refer to the DRAM supplier data sheet and/or the DIMM SPD to determine if DDR4 SDRAM devices support the following options or requirements referred to in this material.

CXMT Privileged and Confidential

Table 7-13 IPP Specifications (Rev. M)

Symbol	Width	2666	Unit
IPP0	x8	21.0	mA
	x16	27.3	mA
IPP1	x8	21.0	mA
	x16	27.3	mA
IPP2N	x8	4.1	mA
	x16	4.1	mA
IPP3N	x8	13.2	mA
	x16	13.2	mA
IPP5B	x8	42.4	mA
	x16	42.4	mA
IPP6N	x8	6.0	mA
	x16	6.0	mA
IPP7	x8	37.9	mA
	x16	56.5	mA

Note:

- 1 Maximum limits are specified
- 2 Users should refer to the DRAM supplier data sheet and/or the DIMM SPD to determine if DDR4 SDRAM devices support the following options or requirements referred to in this material.

Table 7-14 IDD6 Specification

Symbol	Temperature Range	2666	2666	Unit	Note
		x8	x16		
IDD6R	0 ~ 45 °C	24.7	24.7	mA	4,6,9
IDD6N	0 ~ 85 °C	31.4	31.4	mA	3,4
IDD6E	0 ~ 95 °C	40.4	56.6	mA	4,5,6
IDD6A	0 ~ 95 °C	40.3	56.4	mA	4,6,7,8

Note:

- 1 Some IDD currents are higher for x16 organization due to larger page-size architecture.
- 2 Max. values for IDD currents considering worst case conditions of process, temperature and voltage.
- 3 Applicable for MR2 settings A6=0 and A7=0.
- 4 Supplier data sheets include a max value for IDD6.
- 5 Applicable for MR2 settings A6=0 and A7=1. IDD6E is only specified for devices which support the Extended Temperature Range feature.
- 6 Refer to the supplier data sheet for the value specification method (e.g. max, typical) for IDD6E and IDD6A
- 7 Applicable for MR2 settings A6=1 and A7=0. IDD6A is only specified for devices which support the Auto Self Refresh feature.
- 8 The number of discrete temperature ranges supported and the associated Ta - Tz values are supplier/design specific. Temperature ranges are specified for all supported values of TOPER. Refer to supplier data sheet for more information.
- 9 Applicable for MR2 settings MR2 [A7:A6 = 01]: Reduced Temperature range. IDD6R is verified by design and characterization, and may not be subject to production test

8. Input/Output Capacitance

Table 8-1 Silicon Pad I/O Capacitance

Symbol	Parameter	1600/1866/2133		2400/2666		Unit	Note
		Min	Max	Min	Max		
C_{IO}	Input/output capacitance	0.55	1.4	0.55	1.15	pF	1,2,3
C_{DIO}	Input/output capacitance delta	-0.1	0.1	-0.1	0.1	pF	1,2,3,11
C_{DDQS}	Input/output capacitance delta DQS_t and DQS_c	--	0.05	-	0.05	pF	1,2,3,5
C_{CK}	Input capacitance, CK_t and CK_c	0.2	0.8	0.2	0.7	pF	1,3
C_{DCK}	Input capacitance delta CK_t and CK_c	-	0.05	-	0.05	pF	1,3,4
C_I	Input capacitance (CTRL, ADD, CMD pins only)	0.2	0.8	0.2	0.7	pF	1,3,6
C_{DI_CTRL}	Input capacitance delta (All CTRL pins only)	-0.1	0.1	-0.1	0.1	pF	1,3,7,8
$C_{DI_ADD_CMD}$	Input capacitance delta (All ADD/ CMD pins only)	-0.1	0.1	-0.1	0.1	pF	1,2,9,10
C_{ALERT}	Input/output capacitance of ALERT	0.5	1.5	0.5	1.5	pF	1,3
C_{ZQ}	Input/output capacitance of ZQ	0.5	2.3	0.5	2.3	pF	1,3,12
C_{TEN}	Input capacitance of TEN	0.2	2.3	0.2	2.3	pF	1,3,13

Note:

- 1 This parameter is not subject to production test. It is verified by design and characterization. The silicon only capacitance is validated by deembedding the package L & C parasitic. The capacitance is measured with VDD, VDDQ, VSS, VSSQ applied with all other signal pins floating. Measurement procedure TBD.
- 2 DQ, DM_n, DQS_T, DQS_C, TDQS_T, TDQS_C. Although the DM, TDQS_T and TDQS_C pins have different functions, the loading matches DQ and DQS
- 3 This parameter applies to monolithic devices only; stacked/dual-die devices are not covered here
- 4 Absolute value CK_T-CK_C
- 5 Absolute value of $C_{IO}(DQS_T)-C_{IO}(DQS_C)$
- 6 CI applies to ODT, CS_n, CKE, A0-A17, BA0-BA1, BG0-BG1, RAS_n/A16, CAS_n/A15, WE_n/A14, ACT_n and PAR.
- 7 C_{DI_CTRL} applies to ODT, CS_n and CKE
- 8 $C_{DI_CTRL} = C_i(CTRL)-0.5*(C_i(CLK_T)+C_i(CLK_C))$
- 9 $C_{DI_ADD_CMD}$ applies to, A0-A17, BA0-BA1, BG0-BG1, RAS_n/A16, CAS_n/A15, WE_n/A14, ACT_n and PAR.
- 10 $C_{DI_ADD_CMD} = C_i(ADD_CMD)-0.5*(C_i(CLK_T)+C_i(CLK_C))$
- 11 $C_{DIO} = C_{IO}(DQ,DM)-0.5*(C_{IO}(DQS_T)+C_{IO}(DQS_C))$
- 12 Maximum external load capacitance on ZQ pin: tbd pF.
- 13 TEN pin may be DRAM internally pulled low through a weak pull-down resistor to VSS. In this case CTEN might not be valid and system shall verify TEN signal with Vendor specific information.

Table 8-2 DRAM Package Electrical Specifications (x8)

Symbol	Parameter	1600/1866/2133/2400/2666		Unit	Note
		Min	Max		
Z _{IO}	Input/output Zpkg	45	85	Ω	1,2,4,5,10,11
T _{dIO}	Input/output Pkg Delay	14	42	ps	1,3,4,5,10,11
L _{io}	Input/Output Lpkg	-	3.3	nH	11,12
C _{io}	Input/Output Cpkg	-	0.78	pF	11,13
Z _{IO DQS}	DQS_t and DQS_c Zpkg	45	85	Ω	1,2,5,7,10
T _{dIO DQS}	DQS_t and DQS_c Pkg Delay	14	42	ps	1,3,5,7,10
L _{io DQS}	DQS Lpkg	-	3.3	nH	11,12
C _{io DQS}	DQS Cpkg	-	0.78	pF	11,13
DZ _{DIO DQS}	Delta Zpkg DQS_t, DQS_c	-	10	Ω	1,2,5,7,10
D _{TdDIO DQS}	Delta Delay DQS_t, DQS_c	-	5	ps	1,3,5,7,10
Z _{I CTRL}	Input- CTRL pins Zpkg	50	90	Ω	1,2,5,9,10,11
T _{dI CTRL}	Input- CTRL pins Pkg Delay	14	42	ps	1,3,5,9,10,11
L _{i CTRL}	Input CTRL Lpkg	-	3.4	nH	11,12
C _{i CTRL}	Input CTRL Cpkg	-	0.7	pF	11,13
Z _{IADD_CMD}	Input- CMD ADD pins Zpkg	50	90	Ω	1,2,5,8,10,11
T _{dIADD_CMD}	Input- CMD ADD pins Pkg Delay	14	45	ps	1,3,5,8,10,11
L _{IADD_CMD}	Input CMD ADD Lpkg	-	3.6	nH	11,12
C _{IADD_CMD}	Input CMD ADD Cpkg	-	0.74	pF	11,13
Z _{CK}	CLK_t and CLK_c Zpkg	50	90	Ω	1,2,5,10,11
T _{dCK}	CLK_t and CLK_c Pkg Delay	14	42	ps	1,3,5,10,11
L _{i CLK}	Input CLK Lpkg	-	3.4	nH	11,12
C _{i CLK}	Input CLK Cpkg	-	0.7	pF	11,13
DZ _{DCK}	Delta Zpkg CK_t and CK_c	-	10	Ω	1,2,5,6,10
D _{TdCK}	Delta Delay CK_t and CK_c	-	5	ps	1,3,5,6,10
Z _{OZQ}	ZQ Zpkg	40	100	Ω	1,2,5,10,11
T _{dO ZQ}	ZQ Delay	20	90	ps	1,3,5,10,11
Z _{O ALERT}	ALERT Zpkg	40	100	Ω	1,2,5,10,11
T _{dO ALERT}	ALERT Delay	20	55	ps	1,3,5,10,11

Note:

1 This parameter is not subject to production test. It is verified by design and characterization. The package parasitic(L & C) are validated using package only samples. The capacitance is measured with VDD, VDDQ, VSS, VSSQ shorted with all other signal pins floating. The inductance is measured with VDD, VDDQ, VSS and VSSQ shorted and all other signal pins shorted at the die side(not pin). Measurement procedure tbd

2 Package only impedance (Zpkg) is calculated based on the Lpkg and Cpkg total for a given pin where:

$$Z_{pkg} \text{ (total per pin)} = \sqrt{L_{pkg}/C_{pkg}}$$

3 Package only delay(Tpkg) is calculated based on Lpkg and Cpkg total for a given pin where:

$$T_{d_{pkg}} \text{ (total per pin)} = \sqrt{L_{pkg}/C_{pkg}}$$

4 Z & Td IO applies to DQ, DM, DQS_C, DQS_T, TDQS_T and TDQS_C

5 This parameter applies to monolithic devices only; stacked/dual-die devices are not covered here

6 Absolute value of ZCK_t-ZCK_c for impedance(Z) or absolute value of TdCK_t-TdCK_c for delay(Td).

7 Absolute value of ZIO(DQS_t)-ZIO(DQS_c) for impedance(Z) or absolute value of TdIO(DQS_t)-TdIO(DQS_c) for delay(Td)

8 ZI & Td ADD CMD applies to A0-A17, BA0-BA1, BG0-BG1, RAS_n CAS_n, WE_n.

9 ZI & Td CTRL applies to ODT, CS_n and CKE.

10 This table applies to monolithic X4 and X8 devices.

11 Package implementations shall meet spec if the Zpkg and Pkg Delay fall within the ranges shown, and the maximum Lpkg and Cpkg do not exceed the maximum values shown.

12 It is assumed that Lpkg can be approximated as $L_{pkg} = Z_o * T_d$.

13 It is assumed that Cpkg can be approximated as $C_{pkg} = T_d / Z_o$.

Table 8-3 DRAM Package Electrical Specifications (x16)

Symbol	Parameter	1600/1866/2133/2400		2666		Unit	Note
		Min	Max	Min	Max		
Z _{io}	Input/output Zpkg	45	85	45	85	Ω	1
T _{dio}	Input/output Pkg Delay	14	45	14	45	ps	1
L _{io}	Input/Output Lpkg	-	3.4	-	3.4	nH	1,2
C _{io}	Input/Output Cpkg	-	0.82	-	0.82	pF	1,3
Z _{io DQS}	DQS_t and DQS_c Zpkg	45	85	45	85	Ω	1
T _{dio DQS}	DQS_t and DQS_c Pkg Delay	14	45	14	45	ps	1
L _{io DQS}	DQS Lpkg	-	3.4	-	3.4	nH	1,2
C _{io DQS}	DQS Cpkg	-	0.82	-	0.82	pF	1,3
DZ _{DIO DQS}	Delta Zpkg DQSU_t, DQSU_c	-	10	-	10	Ω	-
	Delta Zpkg DQSL_t, DQSL_c	-	10	-	10	Ω	-
D _{TdDIO DQS}	Delta Delay DQSU_t, DQSU_c	-	5	-	5	ps	-
	Delta Delay DQSL_t, DQSL_c	-	5	-	5	ps	-
Z _{I CTRL}	Input- CTRL pins Zpkg	50	90	50	90	Ω	1
T _{dIADD_CMD}	Input- CTRL pins Pkg Delay	14	42	14	42	ps	1
L _{I CTRL}	Input CTRL Lpkg	-	3.4	-	3.4	nH	1,2
C _{I CTRL}	Input CTRL Cpkg	-	0.7	-	0.7	pF	1,3
Z _{IADD_CMD}	Input- CMD ADD pins Zpkg	50	90	50	90	Ω	1
T _{dIADD_CMD}	Input- CMD ADD pins Pkg Delay	14	52	14	52	ps	1
L _{IADD_CMD}	Input CMD ADD Lpkg	-	3.9	-	3.9	nH	1,2
C _{IADD_CMD}	Input CMD ADD Cpkg	-	0.86	-	0.86	pF	1,3

DRAM Package Electrical Specifications (x16) (cont'd)

Symbol	Parameter	1600/1866/2133/2400		2666		Unit	Note
		Min	Max	Min	Max		
Z _{CK}	CLK_t and CLK_c Zpkg	50	90	50	90	Ω	-
T _{dCK}	CLK_t and CLK_c Pkg Delay	14	42	14	42	ps	-
L _{iCLK}	Input CLK Lpkg	-	3.4	-	3.4	nH	-
C _{iCLK}	Input CLK Cpkg	-	0.7	-	0.7	pF	-
DZ _{DCK}	Delta Zpkg CK_t and CK_c	-	10	-	10	Ω	-
D _{TdCK}	Delta Delay CK_t and CK_c	-	5	-	5	ps	-
Z _{OZQ}	ZQ Zpkg	40	100	40	100	Ω	-
T _{dOZQ}	ZQ Delay	20	90	20	90	ps	-
Z _{OALERT}	ALERT Zpkg	40	100	40	100	Ω	-
T _{dOALERT}	ALERT Delay	20	55	20	55	ps	-

Note:

- 1 Package implementations shall meet spec if the Zpkg and Pkg Delay fall within the ranges shown, and the maximum Lpkg and Cpkg do not exceed the maximum value shown
- 2 It is assumed that Lpkg can be approximated as $L_{pkg} = Z_o * T_d$
- 3 It is assumed that Cpkg can be approximated as $C_{pkg} = T_d / Z_o$

9. Electrical Characteristics & AC Timing

This chapter introduces the following five topics to build a completely safe operation environment for DDR4 SDRAM:

- Reference Load for AC Timing and Output Slew Rate on [Page 104](#)
- tREFI on [Page 105](#)
- Clock Specification on [Page 105](#)
- Timing Parameters by Speed Grade on [Page 107](#)
- Rounding Algorithms on [Page 129](#)
- DQ Input Receiver Compliance Mask for Voltage and Timing on [Page 130](#)
- Command, Control, and Address Setup, Hold and Derating on [Page 136](#)

9.1 Reference Load for AC Timing and Output Slew Rate

Figure 9-1 represents the effective reference load of 50 ohms used in defining the relevant AC timing parameters of the device as well as output slew rate measurements.

RON nominal of DQ, DQS_t and DQS_c drivers uses 34 ohms to specify the relevant AC timing parameter values of the device.

- The maximum DC High level of Output signal = $1.0 \cdot VDDQ$,
- The minimum DC Low level of Output signal = $\{ 34 / (34 + 50) \} \cdot VDDQ = 0.4 \cdot VDDQ$
- The nominal reference level of an Output signal can be approximated by the following:
- The center of maximum DC High and minimum DC Low = $\{ (1 + 0.4) / 2 \} \cdot VDDQ = 0.7 \cdot VDDQ$

The actual reference level of Output signal might vary with driver RON and reference load tolerances. Thus, the actual reference level or midpoint of an output signal is at the widest part of the output signal's eye. Prior to measuring AC parameters, the reference level of the verification tool should be set to an appropriate level.

It is not intended as a precise representation of any particular system environment or a depiction of the actual load presented by a production tester. System designers should use IBIS or other simulation tools to correlate the timing reference load to a system environment. Manufacturers correlate to their production test conditions, generally one or more coaxial transmission lines terminated at the tester electronics.

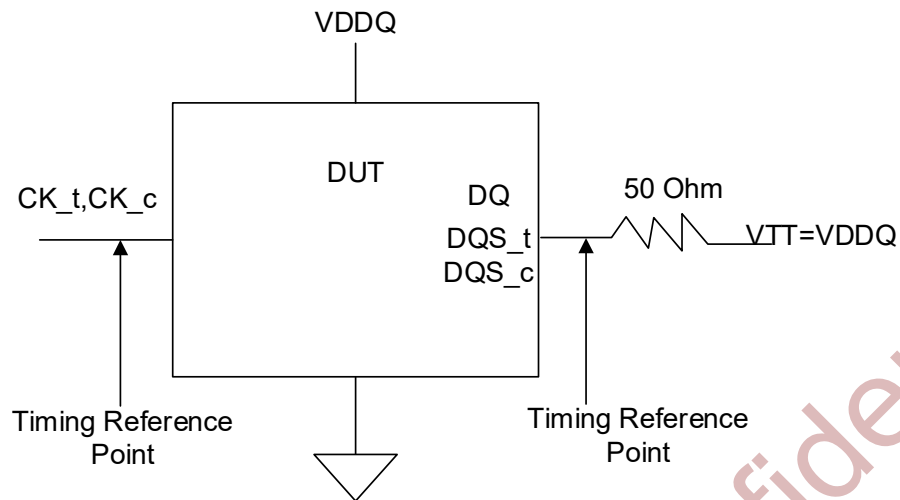

Figure 9-1 Reference Load for AC Timing and Output Slew Rate

9.2 tREFI

Average periodic Refresh interval (tREFI) of DDR4 SDRAM is defined as shown in Table 9-1 below.

Table 9-1 tREFI by Device Density

Parameter	Symbol	8Gb	Unit
Average periodic refresh interval	tREFI	$0^{\circ}\text{C} \leq \text{TCASE} \leq 85^{\circ}\text{C}$	7.8
		$85^{\circ}\text{C} < \text{TCASE} \leq 95^{\circ}\text{C}$	3.9

9.3 Clock Specification

The jitter specified is a random jitter meeting a Gaussian distribution. Input clocks violating the min/max values may result in malfunction of the DDR4 SDRAM device.

9.3.1 Definition for tCK(abs)

tCK(abs) is defined as the absolute clock period, as measured from one rising edge to the next consecutive rising edge. tCK(abs) is not subject to production test.

9.3.2 Definition for tCK(avg)

tCK(avg) is calculated as the average clock period across any consecutive 200 cycle window, where each clock period is calculated from rising edge to rising edge.

$$tCK(avg) = \left[\frac{N}{\sum_{j=1}^N tCK(abs)_j} \right] / N \quad N=200$$

9.3.3 Definition for tCH(avg) and tCL(avg)

tCH(avg) is defined as the average high pulse width, as calculated across any consecutive 200 high pulses.

$$tCH(avg) = \left[\frac{N}{\sum_{j=1}^N tCH_j} \right] / \{N \times tCK(avg)\} \quad N=200$$

tCL(avg) is defined as the average low pulse width, as calculated across any consecutive 200 low pulses.

$$tCH(avg) = \left[\frac{N}{\sum_{j=1}^N tCH_j} \right] / \{N \times tCK(avg)\} \quad N=200$$

9.3.4 Definition for tERR(nper)

tERR is defined as the cumulative error across n consecutive cycles of n x tCK(avg). tERR is not subject to production test.

9.4 Timing Parameters by Speed Grade

9.4.1 Timing Parameters by Speed Bin for DDR4-1600 to 2400

Table 9-2 Timing Parameters by Speed Bin for DDR4-1600 to 2400

Speed		DDR4-1600		DDR4-1866		DDR4-2133		DDR4-2400		Unit	Note
Parameter	Symbol	Min	Max	Min	Max	Min	Max	Min	Max		
Clock Timing											
Minimum Clock Cycle Time (DLL off mode)	tCK (DLL_OFF)	8	20	8	20	8	20	8	20	ns	
Average Clock Period	tCK (avg)	1.25	<1.5	1.071	<1.25	0.937	<1.071	0.833	<0.937	ns	35, 36
Average high pulse width	tCH (avg)	0.48	0.52	0.48	0.52	0.48	0.52	0.48	0.52	tCK (avg)	
Average low pulse width	tCL (avg)	0.48	0.52	0.48	0.52	0.48	0.52	0.48	0.52	tCK (avg)	
Absolute Clock Period	tCK (abs)	Min : tCK(avg)min + tJIT(per)min_tot Max : tCK(avg)max + tJIT(per)max_tot								tCK (avg)	
Absolute clock HIGH pulse width	tCH (abs)	0.45	-	0.45	-	0.45	-	0.45	-	tCK (avg)	23
Absolute clock LOW pulse width	tCL (abs)	0.45	-	0.45	-	0.45	-	0.45	-	tCK (avg)	24
Clock Period Jitter- total	JIT (per)_tot	-63	63	-54	54	-47	47	-42	42	ps	23, 25
Clock Period Jitter- deterministic	JIT (per)_dj	-31	31	-27	27	-23	23	-21	21	ps	26
Clock Period Jitter during DLL locking period	tJIT (per, lck)	-50	50	-43	43	-38	38	-33	33	ps	
Cycle to Cycle Period Jitter	tJIT (cc)	-	125	-	107	-	94	-	83	ps	
Cycle to Cycle Period Jitter during DLL locking period	tJIT (cc, lck)	-	100	-	86	-	75	-	67	ps	
Cumulative error across 2 cycles	tERR (2per)	-92	92	-79	79	-69	69	-61	61	ps	
Cumulative error across 3 cycles	tERR (3per)	-109	109	-94	94	-82	82	-73	73	ps	
Cumulative error across 4 cycles	tERR (4per)	-121	121	-104	104	-91	91	-81	81	ps	
Cumulative error across 5 cycles	tERR (5per)	-131	131	-112	112	-98	98	-87	87	ps	
Cumulative error across 6 cycles	tERR (6per)	-139	139	-119	119	-104	104	-92	92	ps	
Cumulative error across 7 cycles	tERR (7per)	-145	145	-124	124	-109	109	-97	97	ps	
Cumulative error across 8 cycles	tERR (8per)	-151	151	-129	129	-113	113	-101	101	ps	
Cumulative error across 9 cycles	tERR (9per)	-156	156	-134	134	-117	117	-104	104	ps	
Cumulative error across 10 cycles	tERR (10per)	-160	160	-137	137	-120	120	-107	107	ps	
Cumulative error across 11 cycles	tERR (11per)	-164	164	-141	141	-123	123	-110	110	ps	
Cumulative error across 12 cycles	tERR (12per)	-168	168	-144	144	-126	126	-112	112	ps	
Cumulative error across 13 cycles	tERR (13per)	-172	172	-147	147	-129	129	-114	114	ps	

Speed		DDR4-1600		DDR4-1866		DDR4-2133		DDR4-2400		Unit	Note
Parameter	Symbol	Min	Max	Min	Max	Min	Max	Min	Max		
Cumulative error across 14 cycles	tERR (14per)	-175	175	-150	150	-131	131	-116	116	ps	
Cumulative error across 15 cycles	tERR (15per)	-178	178	-152	152	-133	133	-118	118	ps	
Cumulative error across 16 cycles	tERR (16per)	-180	189	-155	155	-135	135	-120	120	ps	
Cumulative error across 17 cycles	tERR (17per)	-183	183	-157	157	-137	137	-122	122	ps	
Cumulative error across 18 cycles	tERR (18per)	-185	185	-159	159	-139	139	-124	124	ps	
Cumulative error across n = 13, 14 . . . 49, 50 cycles	tERR (nper)	tERR (nper)min = ((1 + 0.68ln(n)) * tJIT (per)_total min)								ps	
		tERR (nper)max = ((1 + 0.68ln(n)) * tJIT (per)_total max)									
Command and Address setup time to CK_t,CK_c referenced to Vih(ac) / Vil(ac) levels	tIS (base)	115	-	100	-	80	-	62	-	ps	
Command and Address setup time to CK_t,CK_c referenced to Vref levels	tIS (Vref)	215	-	200	-	180	-	162	-	ps	
Command and Address hold time to CK_t,CK_c referenced to Vih(dc) / Vil(dc) levels	tIH (base)	140	-	125	-	105	-	87	-	ps	
Command and Address hold time to CK_t,CK_c referenced to Vref levels	tIH (Vref)	215	-	200	-	180	-	162	-	ps	
Control and Address Input pulse width for each input	tIPW	600	-	525	-	460	-	410	-	ps	
Command and Address Timing											
CAS_n to CAS_n command delay for same bank group	tCCD_L	Max (5nCK, 6.250ns)	-	Max (5nCK, 5.355ns)	-	Max (5nCK, 5.355ns)	-	Max (5nCK, 5ns)	-	nCK	34
CAS_n to CAS_n command delay for different bank group	tCCD_S	4	-	4	-	4	-	4	-	nCK	34
ACTIVATE to ACTIVATE Command delay to different bank group for 2KB page size	tRRD_S (2K)	Max (4nCK, 6ns)	-	Max (4nCK, 5.3ns)	-	Max (4nCK, 5.3ns)	-	Max (4nCK, 5.3ns)	-	nCK	34
ACTIVATE to ACTIVATE Command delay to different bank group for 1KB page size	tRRD_S (1K)	Max (4nCK, 5ns)	-	Max (4nCK, 4.2ns)	-	Max (4nCK, 3.7ns)	-	Max (4nCK, 3.3ns)	-	nCK	34
ACTIVATE to ACTIVATE Command delay to different bank group for 1/2KB page size	tRRD_S (1/2K)	Max (4nCK, 5.0ns)	-	Max (4nCK, 4.2ns)	-	Max (4nCK, 3.7ns)	-	Max (4nCK, 3.3ns)	-	nCK	34
ACTIVATE to ACTIVATE Command delay to same bank group for 2KB page size	tRRD_L (2K)	Max (4nCK, 7.5ns)	-	Max (4nCK, 6.4ns)	-	Max (4nCK, 6.4ns)	-	Max (4nCK, 6.4ns)	-	nCK	34
ACTIVATE to ACTIVATE Command delay to same bank group for 1KB page size	tRRD_L (1K)	Max (4nCK, 6.0ns)	-	Max (4nCK, 5.3ns)	-	Max (4nCK, 5.3ns)	-	Max (4nCK, 4.9ns)	-	nCK	34

Speed		DDR4-1600		DDR4-1866		DDR4-2133		DDR4-2400		Unit	Note
Parameter	Symbol	Min	Max	Min	Max	Min	Max	Min	Max		
ACTIVATE to ACTIVATE Command delay to same bank group for 1/2KB page size	tRRD_L (1/2K)	Max (4nCK, 6.0ns)	-	Max (4nCK, 5.3ns)	-	Max (4nCK, 5.3.0ns)	-	Max (4nCK, 4.9ns)	-	nCK	34
Four activate window for 2KB page size	tFAW_2K	Max (28nCK, 35ns)	-	Max (28nCK, 30ns)	-	Max (28nCK, 30ns)	-	Max (28nCK, 30ns)	-	ns	34
Four activate window for 1KB page size	tFAW_1K	Max (20nCK, 25ns)	-	Max (20nCK, 23ns)	-	Max (20nCK, 21ns)	-	Max (20nCK, 21ns)	-	ns	34
Four activate window for 1/2KB page size	tFAW_1/2K	Max (16nCK, 20ns)	-	Max (16nCK, 17ns)	-	Max (16nCK, 15ns)	-	Max (16nCK, 13ns)	-	ns	34
Delay from start of internal Write transaction to internal read command for same bank group	tWTR_S	Max (2nCK, 2.5ns)	-	Max (2nCK, 2.5ns)	-	Max (2nCK, 2.5ns)	-	Max (2nCK, 2.5ns)	-	ns	1,2,34
Delay from start of internal write transaction to internal read command for same bank group	tWTR_L	Max (4nCK, 7.5ns)	-	Max (4nCK, 7.5ns)	-	Max (4nCK, 7.5ns)	-	Max (4nCK, 7.5ns)	-	ns	1,34
Internal READ Command to PRE-CHARGE Command delay	tRTP	Max (4nCK, 7.5ns)	-	Max (4nCK, 7.5ns)	-	Max (4nCK, 7.5ns)	-	Max (4nCK, 7.5ns)	-	ns	34
WRITE recovery time	tWR	15	-	15	-	15	-	15	-	ns	1
Write recovery time when CRC and DM are enabled	tWR_CRC_DM	tWR + max (4nCK, 3.75ns)	-	tWR + max (5CK, 3.75ns)	-	tWR + max (5nCK, 3.75ns)	-	tWR + max (5nCK, 3.75ns)	-	ns	1, 28
delay from start of internal write trans- action to internal read command for different bank group with both CRC and DM enabled	tWTR_S_CRC_DM	tWTR_S + max (4nCK, 3.75ns)	-	tWTR_S + max (5nCK, 3.75ns)	-	tWTR_S + max (5nCK, 3.75ns)	-	tWTR_S + max (5nCK, 3.75ns)	-	ns	2, 29, 34
delay from start of internal write trans- action to internal read command for same bank group with both CRC and DM enabled	tWTR_L_CRC_DM	tWTR_L + max (4nCK, 3.75ns)	-	tWTR_L + max (5nCK, 3.75ns)	-	tWTR_L + max (5nCK, 3.75ns)	-	tWTR_L + max (5nCK, 3.75ns)	-	ns	3, 30, 34
DLL locking time	tDLLK	597	-	597	-	768	-	768	-	nCK	
Mode Register Set command cycle time	tMRD	8	-	8	-	8	-	8	-	nCK	
Mode Register Set command update delay	tMOD	max (24nCK, 15ns)	-	max (24nCK, 15ns)	-	max (24nCK, 15ns)	-	max (24nCK, 15ns)	-	nCK	50
Multi-Purpose Register Recovery Time	tMPRR	1	-	1	-	1	-	1	-	nCK	33
Multi Purpose Register Write Recov- erty Time	tWR_MPR	tMOD (min) + AL + PL	-	tMOD (min) + AL + PL	-	tMOD (min) + AL + PL	-	tMOD(min) + AL + PL	-	ns	

Speed		DDR4-1600		DDR4-1866		DDR4-2133		DDR4-2400		Unit	Note
Parameter	Symbol	Min	Max	Min	Max	Min	Max	Min	Max		
Auto precharge write recovery + pre-charge time	tDAL (min)	Programmed WR + roundup (tRP / tCK(avg))								nCK	
DQ0 or DQL0 driven to 0 set-up time to first DQS rising edge	tPDA_S	0.5	-	0.5	-	0.5	-	0.5	-	UI	45,47
DQ0 or DQL0 driven to 0 hold time from last DQS falling edge	tPDA_H	0.5	-	0.5	-	0.5	-	0.5	-	UI	46,47
CS_n to Command Address Latency											
CS_n to Command Address Latency	tCAL	max (3nCK, 3.748 ns)	-	max (3nCK, 3.748 ns)	-	max (3nCK, 3.748 ns)	-	max (3nCK, 3.748 ns)	-	nCK	
Mode Register Set command cycle time in CAL mode	tMRD_tCAL	tMOD + tCAL	-	tMOD + tCAL	-	tMOD + tCAL	-	tMOD + tCAL	-	nCK	
Mode Register Set update delay in CAL mode	tMOD_tCAL	tMOD + tCAL	-	tMOD + tCAL	-	tMOD + tCAL	-	tMOD + tCAL	-	nCK	
DRAM Data Timing											
DQS_t,DQS_c to DQ skew, per group, per access	tDQSQ	-	0.16	-	0.16	-	0.16	-	0.17	tCK (avg)/2	13,18,39,49
DQ output hold time from DQS_t,DQS_c	tQH	0.76	-	0.76	-	0.76	-	0.74	-	tCK (avg)/2	13,17,18,39,49
Data Valid Window per device per UI: (tQH - tDQSQ) of each UI on a given DRAM	tDVWd	0.63	-	0.63	-	0.64	-	0.64	-	UI	17,18,39,49
Data Valid Window per pin per UI : (tQH- tDQSQ) each UI on a pin of a given DRAM	tDVWp	0.66	-	0.66	-	0.69	-	0.72	-	UI	17,18,39,49
DQ low impedance time from CK_t,CK_c	tLZ (DQ)	-450	225	-390	195	-360	180	-330	175	ps	39
DQ high impedance time from CK_t,CK_c	tHZ (DQ)	-	225	-	195	-	180	-	175	ps	39
Data Strobe Timing											
DQS_t, DQS_c differential READ Preamble(1 clock preamble)	tRPRE	0.9	Note 44	0.9	Note 44	0.9	Note 44	0.9	Note 44	nCK	39, 40
DQS_t, DQS_c differential READ Preamble(2 clock preamble)	tRPRE2	NA	NA	NA	NA	NA	NA	1.8	Note 44	tCK	39, 41
DQS_t, DQS_c differential READ Postamble	tRPST	0.33	Note 45	0.33	Note 45	0.33	Note 45	0.33	Note 45	tCK	39
DQS_t,DQS_c differential output high time	tQSH	0.4	-	0.4	-	0.4	-	0.4	-	tCK	21,39
DQS_t,DQS_c differential output low time	tQSL	0.4	-	0.4	-	0.4	-	0.4	-	tCK	20,39
DQS_t, DQS_c differential WRITE Preamble(1 clock preamble)	tWPRE	0.9	-	0.9	-	0.9	-	0.9	-	tCK	42



Speed		DDR4-1600		DDR4-1866		DDR4-2133		DDR4-2400		Unit	Note
Parameter	Symbol	Min	Max	Min	Max	Min	Max	Min	Max		
DQS_t, DQS_c differential WRITE Preamble(2 clock preamble)	tWPRE2	NA	NA	NA	NA	NA	NA	1.8	-	tCK	43
DQS_t, DQS_c differential WRITE Postamble	tWPST	0.33	-	0.33	-	0.33	-	0.33	-	tCK	
DQS_t and DQS_c low-impedance time (Referenced from RL-1)	tLZ (DQS)	-450	225	-390	195	-360	180	-330	175	ps	39
DQS_t and DQS_c high-impedance time (Referenced from RL+BL/2)	tHZ (DQS)	-	225	-	195	-	180	-	175	ps	39
DQS_t, DQS_c differential input low pulse width	tDQSL	0.46	0.54	0.46	0.54	0.46	0.54	0.46	0.54	tCK	
DQS_t, DQS_c differential input high pulse width	tDQSH	0.46	0.54	0.46	0.54	0.46	0.54	0.46	0.54	tCK	
DQS_t, DQS_c rising edge to CK_t, CK_c rising edge (1 clock preamble)	tDQSS	-0.27	0.27	-0.27	0.27	-0.27	0.27	-0.27	0.27	tCK	42
DQS_t, DQS_c rising edge to CK_t, CK_c rising edge (2 clock preamble)	tDQSS2	NA	NA	NA	NA	NA	NA	TBD	TBD	tCK	43
DQS_t, DQS_c falling edge setup time to CK_t, CK_c rising edge	tDSS	0.18	-	0.18	-	0.18	-	0.18	-	tCK	
DQS_t, DQS_c falling edge hold time from CK_t, CK_c rising edge	tDSH	0.18	-	0.18	-	0.18	-	0.18	-	tCK	
DQS_t, DQS_c rising edge output vari-ance window per DRAM	tDQSCKI (DLL On)	-	370	-	330	-	310	-	290	ps	37,38,39
DQS_t, DQS_c rising edge output timing locatino from rising CK_t, CK_c with DLL On mode	tDQSCK (DLL On)	-225	225	-195	195	-180	180	-175	175	ps	37,38,39
MPSM Timing											
Command path disable delay upon MPSM entry	tMPED	tMOD (min) + tCPDED (min)								tCK	
Valid clock requirement after MPSM entry	tCKMPE	tMOD (min) + tCPDED (min)								tCK	
Valid clock requirement before MPSM exit	tCKMPX	tCKSRX (min)								tCK	
Exit MPSM to commands not requiring a locked DLL	tXMP	tXS (min)								tCK	
Exit MPSM to commands requiring a locked DLL	tXMPDLL	tXMP (min) + tXSDLL (min)								tCK	
CS setup time to CKE	tMPX_S	tISmin + tIHmin								ns	
Calibration Timing											
Power-up and RESET calibration time	tZQinit	1024	-	1024	-	1024	-	1024	-	nCK	

Speed		DDR4-1600		DDR4-1866		DDR4-2133		DDR4-2400		Unit	Note
Parameter	Symbol	Min	Max	Min	Max	Min	Max	Min	Max		
Normal operation Full calibration time	tZQoper	512	-	512	-	512	-	512	-	nCK	
Normal operation Short calibration time	tZQCS	128	-	128	-	128	-	128	-	nCK	
Reset/Self Refresh Timing											
Exit Reset from CKE HIGH to a valid command	tXPR	Max (5nCK, tRFC (min) + 10ns)	-	Max (5nCK, tRFC (min) + 10ns)	-	Max (5nCK, tRFC (min) + 10ns)	-	Max (5nCK, tRFC (min) + 10ns)	-	nCK	
Exit Self Refresh to commands not requiring a locked DLL	tXS	tRFC (min) + 10ns	-	tRFC (min) + 10ns	-	tRFC (min) + 10ns	-	tRFC (min) + 10ns	-	nCK	
SRX to commands not requiring a locked DLL in Self Refresh ABORT	tXS_ABORT (min)	tRFC4 (min) + 10ns	-	tRFC4 (min) + 10ns	-	tRFC4 (min) + 10ns	-	tRFC4 (min) + 10ns	-	nCK	
Exit Self Refresh to ZQCL, ZQCS and MRS (CL, CWL, WR, RTP and Gear Down)	tXS_FAST (min)	tRFC4 (min) + 10ns	-	tRFC4 (min) + 10ns	-	tRFC4 (min) + 10ns	-	tRFC4 (min) + 10ns	-	nCK	
Exit Self Refresh to commands re-quiring a locked DLL	tXSDLL	tDLLK (min)	-	tDLLK (min)	-	tDLLK (min)	-	tDLLK (min)	-	nCK	
Minimum CKE low width for Self re- fresh entry to exit timing	tCKESR	tCKE (min) + 1nCK	-	tCKE (min) + 1nCK	-	tCKE (min) + 1nCK	-	tCKE (min) + 1nCK	-	nCK	
Minimum CKE low width for Self re- fresh entry to exit timing with CA Par- ity enabled	tCKESR_ PAR	tCKE (min) + 1nCK + PL	-	tCKE (min) + 1nCK + PL	-	tCKE (min) + 1nCK + PL	-	tCKE (min) + 1nCK + PL	-	nCK	
Valid Clock Requirement after Self Refresh Entry (SRE) or Power-Down Entry (PDE)	tCKSRE	max (5nCK, 10 ns)	-	max (5nCK, 10 ns)	-	max (5nCK, 10 ns)	-	max(5nCK, 10ns)	-	nCK	
Valid Clock Requirement after Self Refresh Entry (SRE) or Power-Down when CA Parity is enabled	tCKSRE_ PAR	max (5nCK, 10ns) + PL	-	max (5nCK, 10ns) + PL	-	max (5nCK, 10ns) + PL	-	max (5nCK, 10ns) + PL	-	nCK	
Valid Clock Requirement before Self Refresh Exit (SRX) or Power-Down Exit (PDX) or Reset Exit	tCKSRX	max (5nCK, 10ns)	-	max (5nCK, 10ns)	-	max (5nCK, 10ns)	-	max (5nCK, 10ns)	-	nCK	
Power Down Timing											
Exit Power Down with DLL on to any valid command; Exit Precharge Power Down with DLL frozen to commands not requiring a locked DLL	tXP	max (4nCK, 6ns)	-	max (4nCK, 6ns)	-	max (4nCK, 6ns)	-	max (4nCK, 6ns)	-	nCK	
CKE minimum pulse width	tCKE	max (3nCK, 5ns)	-	max (3nCK, 5ns)	-	max (3nCK, 5ns)	-	max(3nCK, 5ns)	-	nCK	31,32
Command pass disable delay	tCPDED	4	-	4	-	4	-	4	-	nCK	
Power Down Entry to Exit Timing	tPD	tCKE (min)	9*tREFI	tCKE (min)	9*tREFI	tCKE (min)	9*tREFI	tCKE (min)	9*tREFI		6

Speed		DDR4-1600		DDR4-1866		DDR4-2133		DDR4-2400		Unit	Note
Parameter	Symbol	Min	Max	Min	Max	Min	Max	Min	Max		
Timing of ACT command to Power Down entry	tACTPDEN	1	-	1	-	2	-	2	-	nCK	7
Timing of PRE or PREA command to Power Down entry	tPRPDEN	1	-	1	-	2	-	2	-	nCK	7
Timing of RD/RDA command to Power Down entry	tRDPDEN	RL + 4 + 1	-	RL + 4 + 1	-	RL + 4 + 1	-	RL + 4 + 1	-	nCK	
Timing of WR command to Power Down entry (BL8OTF, BL8MRS, BC4OTF)	tWRPDEN	WL + 4 + (tWR/tCK(avg))	-	WL + 4 + (tWR/tCK(avg))	-	WL + 4 + (tWR/tCK(avg))	-	WL + 4 + (tWR/tCK(avg))	-	nCK	4
Timing of WRA command to Power Down entry (BL8OTF, BL8MRS, BC4OTF)	tWRAPDEN	WL + 4 + WR + 1	-	WL + 4 + WR + 1	-	WL + 4 + WR + 1	-	WL + 4 + WR + 1	-	nCK	5
Timing of WR command to Power Down entry (BC4MRS)	tWRP-BC4DEN	WL + 2 + (tWR/tCK(avg))	-	WL + 2 + (tWR/tCK(avg))	-	WL + 2 + (tWR/tCK(avg))	-	WL + 2 + (tWR/tCK(avg))	-	nCK	4
Timing of WRA command to Power Down entry (BC4MRS)	tWRAP-BC4DEN	WL + 2 + WR + 1	-	WL + 2 + WR + 1	-	WL + 2 + WR + 1	-	WL + 2 + WR + 1	-	nCK	5
Timing of REF command to Power Down entry	tREFPDEN	1	-	1	-	2	-	2	-	nCK	7
Timing of MRS command to Power Down entry	tMRSPDEN	tMOD (min)	-	tMOD (min)	-	tMOD (min)	-	tMOD (min)	-	nCK	
PDA Timing											
Mode Register Set command cycle time in PDA mode	tMRD_PDA	max (16nCK, 10ns)	-	max (16nCK, 10ns)	-	max (16nCK, 10ns)	-	max (16nCK, 10ns)	-	nCK	
Mode Register Set command update delay in PDA mode	tMOD_PDA	tMOD		tMOD		tMOD		tMOD		nCK	
ODT Timing											
Asynchronous RTT turn-on delay (Power-Down with DLL frozen)	tAONAS	1	9	1	9	1	9	1	9	ns	
Asynchronous RTT turn-off delay (Power-Down with DLL frozen)	tAOFAS	1	9	1	9	1	9	1	9	ns	
RTT dynamic change skew	tADC	0.3	0.7	0.3	0.7	0.3	0.7	0.3	0.7	tCK (avg)	
Write Leveling Timing											
First DQS_t/DQS_n rising edge after write leveling mode is programmed	tWLMRD	40	-	40	-	40	-	40	-	nCK	12
DQS_t/DQS_n delay after write leveling mode is programmed	tWLDQSEN	25	-	25	-	25	-	25	-	nCK	12
Write leveling setup time from rising CK_t, CK_c crossing to rising DQS_t/ DQS_n crossing	tWLS	0.13	-	0.13	-	0.13	-	0.13	-	tCK (avg)	

Speed		DDR4-1600		DDR4-1866		DDR4-2133		DDR4-2400		Unit	Note
Parameter	Symbol	Min	Max	Min	Max	Min	Max	Min	Max		
Write leveling hold time from rising DQS_t/DQS_n crossing to rising CK_t, CK_n crossing	tWLH	0.13	-	0.13	-	0.13	-	0.13	-	tCK (avg)	
Write leveling output delay	tWLO	0	9.5	0	9.5	0	9.5	0	9.5	ns	
Write leveling output error	tWLOE							0	2	ns	
CA Parity Timing											
Commands not guaranteed to be executed during this time	tPAR_UNKNOWN	-	PL	-	PL	-	PL	-	PL	nCK	
Delay from errant command to ALERT_n assertion	tPAR_ALERT_ON	-	PL + 6ns	-	PL + 6ns	-	PL + 6ns	-	PL + 6ns	nCK	
Pulse width of ALERT_n signal when asserted	tPAR_ALERT_PW	48	96	56	112	64	128	72	144	nCK	
Time from when Alert is asserted till controller must start providing DES commands in Persistent CA parity mode	tPAR_ALERT_RSP	-	43	-	50	-	57	-	64	nCK	
Parity Latency	PL	4		4		4		5		nCK	
CRC Error Reporting											
CRC error to ALERT_n latency	tCRC_ALERT	3	13	3	13	3	13	3	13	ns	
CRC ALERT_n pulse width	CRC_ALERT_PW	6	10	6	10	6	10	6	10	nCK	
tREFI											
tRFC1 (min)	8Gb	350	-	350	-	350	-	350	-	ns	34
tRFC2 (min)	8Gb	260	-	260	-	260	-	260	-	ns	34
tRFC4 (min)	8Gb	160	-	160	-	160	-	160	-	ns	34

9.4.2 Timing Parameters by Speed Bin for DDR4-2666 to 3200

Table 9-3 Timing Parameters by Speed Bin for DDR4-2666 to 3200

Speed		DDR4-2666		DDR4-2933		DDR4-3200		Unit	Note
Parameter	Symbol	Min	Max	Min	Max	Min	Max		
Clock Timing									
Minimum Clock Cycle Time (DLL off mode)	tCK (DLL_OFF)	8	20	8	20	8	20	ns	
Average Clock Period	tCK(avg)	0.75	<0.833	0.682	<0.750	0.625	<0.682	ns	35,36
Average high pulse width	tCH(avg)	0.48	0.52	0.48	0.52	0.48	0.52	tCK(avg)	
Average low pulse width	tCL(avg)	0.48	0.52	0.48	0.52	0.48	0.52	tCK(avg)	
Absolute Clock Period	tCK(abs)	Min = tCK(avg)min + tJIT(per)min_tot Max = tCK(avg)max + tJIT(per)max_tot						tCK(avg)	
Absolute clock HIGH pulse width	tCH(abs)	0.45	-	0.45	-	0.45	-	tCK(avg)	23
Absolute clock LOW pulse width	tCL(abs)	0.45	-	0.45	-	0.45	-	tCK(avg)	24
Clock Period Jitter- total	JIT(per)_tot	-38	38	-34	34	-32	32	ps	25
Clock Period Jitter-deterministic	JIT(per)_dj	-19	19	-17	17	-16	16	ps	26
Clock Period Jitter during DLL locking period	tJIT(per, lck)	-30	30	-27	27	-25	25	ps	
Cycle to Cycle Period Jitter	tJIT(cc)	-	75	-	68	-	62	ps	
Cycle to Cycle Period Jitter during DLL locking period	tJIT(cc, lck)	-	60	-	55	-	50	ps	
Cumulative error across 2 cycles	tERR(2per)	-55	55	-50	50	-46	46	ps	
Cumulative error across 3 cycles	tERR(3per)	-66	66	-60	60	-55	55	ps	
Cumulative error across 4 cycles	tERR(4per)	-73	73	-66	66	-61	61	ps	
Cumulative error across 5 cycles	tERR(5per)	-78	78	-71	71	-65	65	ps	
Cumulative error across 6 cycles	tERR(6per)	-83	83	-75	75	-69	69	ps	
Cumulative error across 7 cycles	tERR(7per)	-87	87	-79	79	-73	73	ps	
Cumulative error across 8 cycles	tERR(8per)	-91	91	-83	83	-76	76	ps	

Speed		DDR4-2666		DDR4-2933		DDR4-3200		Unit	Note
Parameter	Symbol	Min	Max	Min	Max	Min	Max		
Cumulative error across 9 cycles	tERR(9per)	-94	94	-85	85	-78	78	ps	
Cumulative error across 10 cycles	tERR(10per)	-96	96	-88	88	-80	80	ps	
Cumulative error across 11 cycles	tERR(11per)	-99	99	-90	90	-83	83	ps	
Cumulative error across 12 cycles	tERR(12per)	-101	101	-92	92	-84	84	ps	
Cumulative error across 13 cycles	tERR(13per)	-103	103	-93	93	-86	86	ps	
Cumulative error across 14 cycles	tERR(14per)	-104	104	-95	95	-87	87	ps	
Cumulative error across 15 cycles	tERR(15per)	-106	106	-97	97	-89	89	ps	
Cumulative error across 16 cycles	tERR(16per)	-108	108	-98	98	-90	90	ps	
Cumulative error across 17 cycles	tERR(17per)	-110	110	-100	100	-92	92	ps	
Cumulative error across 18 cycles	tERR(18per)	-112	112	-101	101	-93	93	ps	
Cumulative error across n = 13, 14 . . . 49, 50 cycles	tERR(nper)	tERR(nper)min = ((1 + 0.68ln(n)) * tJIT(per)_total min)						ps	
		tERR(nper)max = ((1 + 0.68ln(n)) * tJIT(per)_total max)							
Command and Address setup time to CK_t,CK_c referenced to Vih(ac) / Vil(ac) levels	tIS(base)	55	-	48	-	40	-	ps	
Command and Address setup time to CK_t,CK_c referenced to Vref levels	tIS(Vref)	145	-	138	-	130	-	ps	
Command and Address hold time to CK_t,CK_c referenced to Vih(dc) / Vil(dc) levels	tIH(base)	80	-	73	-	65	-	ps	
Command and Address hold time to CK_t,CK_c referenced to Vref levels	tIH(Vref)	145	-	138	-	130	-	ps	
Control and Address Input pulse width for each input	tIPW	385	-	365	-	340	-	ps	
Command and Address Timing									

Speed		DDR4-2666		DDR4-2933		DDR4-3200		Unit	Note
Parameter	Symbol	Min	Max	Min	Max	Min	Max		
CAS_n to CAS_n command delay for same bank group	tCCD_L	Min = Max(5nCK, 5ns)						nCK	34
CAS_n to CAS_n command delay for different bank group	tCCD_S	4	-	4	-	4	-	nCK	34
ACTIVATE to ACTIVATE Command delay to different bank group for 2KB page size	tRRD_S(2K)	Min = Max(4nCK, 5.3ns)						nCK	34
ACTIVATE to ACTIVATE Command delay to different bank group for 1KB page size	tRRD_S(1K)	Min=Max(4nCK, 3.0ns)		Min=Max(4nCK, 2.7ns)		Min=Max(4nCK, 2.5ns)		nCK	34
ACTIVATE to ACTIVATE Command de-lay to different bank group for 1/2KB page size	tRRD_S(1/2K)	Min=Max(4nCK, 3.0ns)		Min=Max(4nCK, 2.7ns)		Min=Max(4nCK, 2.5ns)		nCK	34
ACTIVATE to ACTIVATE Command de-lay to same bank group for 2KB page size	tRRD_L(2K)	Min=Max(4nCK, 6.4ns)		Min=Max(4nCK, 6.4ns)		Min=Max(4nCK, 6.4ns)		nCK	34
ACTIVATE to ACTIVATE Command delay to same bank group for 1KB page size	tRRD_L(1K)	Min=Max(4nCK, 4.9ns)		Min=Max(4nCK, 4.9ns)		Min=Max(4nCK, 4.9ns)		nCK	34
ACTIVATE to ACTIVATE Command delay to different bank group for 1/ 2KB page size	tRRD_L(1/2K)	Min=Max(4nCK, 4.9ns)		Min=Max(4nCK, 4.9ns)		Min=Max(4nCK, 4.9ns)		nCK	34
Four activate window for 2KB page size	tFAW_2K	Min=Max(28nCK, 30ns)		Min=Max(28nCK, 30ns)		Min=Max(28nCK, 30ns)		ns	34
Four activate window for 1KB page size	tFAW_1K	Min=Max(20nCK, 21ns)		Min=Max(20nCK, 21ns)		Min=Max(20nCK, 21ns)		ns	34
Four activate window for 1/2KB page size	tFAW_1/2K	Min=Max(16nCK, 12ns)		Min=Max(16nCK, 10.875ns)		Min=Max(16nCK, 10ns)		ns	34
Delay from start of internal Write transaction to internal Read command for different bank group.	tWTR_S	Min=Max(2nCK, 2.5ns)		Min=Max(2nCK, 2.5ns)		Min=Max(2nCK, 2.5ns)		ns	1,2,34

Speed		DDR4-2666		DDR4-2933		DDR4-3200		Unit	Note
Parameter	Symbol	Min	Max	Min	Max	Min	Max		
Delay from start of internal write transaction to internal read command for same bank group	tWTR_L	Min=Max(4nCK, 7.5ns)		Min=Max(4nCK, 7.5ns)		Min=Max(4nCK, 7.5ns)		ns	1 34
Internal READ Command to PRE- CHARGE Command delay	tRTP	Min=Max(4nCK, 7.5ns)		Min=Max(4nCK, 7.5ns)		Min=Max(4nCK, 7.5ns)		ns	34
WRITE recovery time	tWR	15	-	15	-	15	-	ns	1
Write recovery time when CRC and DM are enabled	tWR_CRC_DM	Min=tWR + Max (5nCK, 3.75ns)						ns	1 28
delay from start of internal write trans- action to internal read command for different bank group with both CRC and DM enabled	tWTR_S_CRC_DM	Min=tWTR_S + Max(5nCK, 3.75ns)						ns	2 29 34
delay from start of internal write trans- action to internal read command for same bank group with both CRC and DM enabled	tWTR_L_CRC_DM	Min=tWTR_L + Max(5nCK, 3.75ns)						ns	3 30 34
DLL locking time	tDLLK	1024	-	1024	-	1024	-	nCK	
Mode Register Set command cycle time	tMRD	8	-	8	-	8	-	nCK	
Mode Register Set command update delay	tMOD	Min=Max(24nCK, 15ns)						nCK	50
Multi-Purpose Register Recovery Time	tMPRR	1	-	1	-	1	-	nCK	33
Multi Purpose Register Write Recov- ery Time	tWR_MPR	Min=tMOD (min) + AL + PL						nCK	
Auto precharge write recovery + pre- charge time	tDAL(min)	Programmed WR + roundup (tRP / tCK(avg))						nCK	
DQ0 or DQL0 driven to 0 set-up time to first DQS rising edge	tPDA_S	0.5	-	0.5	-	0.5	-	UI	45, 47
DQ0 or DQL0 driven to 0 hold time from last DQS falling edge	tPDA_H	0.5	-	0.5	-	0.5	-	UI	46, 47
CS_n to Command Address Latency									
CS_n to Command Address Latency	tCAL	max(3nCK, 3.748 ns)	-	max(3nCK, 3.748 ns)	-	max(3nCK, 3.748 ns)	-	nCK	

Speed		DDR4-2666		DDR4-2933		DDR4-3200		Unit	Note
Parameter	Symbol	Min	Max	Min	Max	Min	Max		
Mode Register Set command cycle time in CAL mode	tMRD_tCAL	tMOD + tCAL	-	tMOD + tCAL	-	tMOD + tCAL	-	nCK	
Mode Register Set update delay in CAL mode	tMOD_tCAL	tMOD + tCAL	-	tMOD + tCAL	-	tMOD + tCAL	-	nCK	
DRAM Data Timing									
DQS_t, DQS_c to DQ skew, per group, per access	tDQSQ	-	0.18	-	0.19	-	TBD	tCK(avg)/2	13, 18, 39, 49
DQ output hold time from DQS_t, DQS_c	tQH	0.74	-	0.72	-	TBD	-	tCK(avg)/2	17, 18, 39, 49
Data Valid Window per device per UI : (tQH - tDQSQ) of each UI on a given DRAM	tDVWd	0.64	-	TBD	-	TBD	-	UI	17, 18, 39, 49
Data Valid Window per pin per UI : (tQH - tDQSQ) each UI on a pin of a given DRAM	tDVWp	0.72	-	TBD	-	0.72	-	UI	17, 18, 39, 49
DQ low impedance time from CK_t, CK_c	tLZ(DQ)	-310	170	-280	165	-250	160	ps	39
DQ high impedance time from CK_t, CK_c	tHZ(DQ)	-	170	-	165	-	160	ps	39
Data Strobe Timing									
DQS_t, DQS_c differential READ Preamble(1 clock preamble)	tRPRE	0.9	Note 44	0.9	Note 44	0.9	Note 44	tCK	39, 40
DQS_t, DQS_c differential READ Preamble(2 clock preamble)	tRPRE2	1.8	Note 44	1.8	Note 44	1.8	Note 44	tCK	39, 41
DQS_t, DQS_c differential READ Postamble	tRPST	0.33	Note 45	0.33	Note 45	0.33	Note 45	tCK	39
DQS_t, DQS_c differential output high time	tQSH	0.4	-	0.4	-	0.4	-	tCK	21, 39
DQS_t, DQS_c differential output low time	tQSL	0.4	-	0.4	-	0.4	-	tCK	20, 39
DQS_t, DQS_c differential WRITE Preamble(1 clock preamble)	tWPRE	0.9	-	0.9	-	0.9	-	tCK	42
DQS_t, DQS_c differential WRITE Preamble(2 clock preamble)	tWPRE2	1.8	-	1.8	-	1.8	-	tCK	43

Speed		DDR4-2666		DDR4-2933		DDR4-3200		Unit	Note
Parameter	Symbol	Min	Max	Min	Max	Min	Max		
DQS_t, DQS_c differential WRITE Postamble	tWPST	0.33	-	0.33	-	0.33	-	tCK	
DQS_t and DQS_c low-impedance time (Referenced from RL-1)	tLZ(DQS)	-310	170	-280	165	-250	160	ps	39
DQS_t and DQS_c high-impedance time (Referenced from RL+BL/2)	tHZ(DQS)	-	170	-	165	-	160	ps	39
DQS_t, DQS_c differential input low pulse width	tDQSL	0.46	0.54	0.46	0.54	0.46	0.54	tCK	
DQS_t, DQS_c differential input high pulse width	tDQSH	0.46	0.54	0.46	0.54	0.46	0.54	tCK	
DQS_t, DQS_c rising edge to CK_t, CK_c rising edge (1 clock preamble)	tDQSS	-0.27	0.27	-0.27	0.27	-0.27	0.27	tCK	42
DQS_t, DQS_c rising edge to CK_t, CK_c rising edge (2 clock preamble)	tDQSS2	TBD	TBD	TBD	TBD	TBD	TBD	tCK	43
DQS_t, DQS_c falling edge setup time to CK_t, CK_c rising edge	tDSS	0.18	-	0.18	-	0.18	-	tCK	
DQS_t, DQS_c falling edge hold time from CK_t, CK_c rising edge	tDSH	0.18	-	0.18	-	0.18	-	tCK	
DQS_t, DQS_c rising edge output variance window per DRAM	tDQSCKI (DLL On)		270		265		260	ps	37, 38,39
DQS_t, DQS_c rising edge output timing locatino from rising CK_t, CK_c with DLL On mode	tDQSCK	-170	170	-165	165	-160	160	ps	37, 38,39
MPSM Timing									
Command path disable delay upon MPSM entry	tMPED	tMOD(min) + tCPDED(min)	-	tMOD(min) + tCPDED(min)	-	tMOD(min) + tCPDED(min)	-	tCK	
Valid clock requirement after MPSM entry	tCKMPE	tMOD(min) + tCPDED(min)	-	tMOD(min) + tCPDED(min)	-	tMOD(min) + tCPDED(min)	-	tCK	
Valid clock requirement before MPSM exit	tCKMPX	tCKSRX(min)	-	tCKSRX(min)	-	tCKSRX(min)	-	tCK	
Exit MPSM to commands not requiring a locked DLL	tXMP	tXS(min)	-	tXS(min)	-	tXS(min)	-	tCK	
Exit MPSM to commands requiring a locked DLL	tXMPDLL	tXMP(min) + tXSDLL(min)	-	tXMP(min) + tXSDLL(min)	-	tXMP(min) + tXSDLL(min)	-	tCK	
CS setup time to CKE	tMPX_S	tISmin + tIHmin	-	tISmin + tIHmin	-	tISmin + tIHmin	-	ns	

Speed		DDR4-2666		DDR4-2933		DDR4-3200		Unit	Note
Parameter	Symbol	Min	Max	Min	Max	Min	Max		
Calibration Timing									
Power-up and RESET calibration time	tZQinit	1024	-	1024	-	1024	-	nCK	
Normal operation Full calibration time	tZQoper	512	-	512	-	512	-	nCK	
Normal operation Short calibration time	tZQCS	128	-	128	-	128	-	nCK	
Reset/Self Refresh Timing									
Exit Reset from CKE HIGH to a valid command	tXPR	Min= max (5nCK,tRFC(min)+ 10ns)						nCK	
Exit Self Refresh to commands not requiring a locked DLL	tXS	Min=tRFC(min) + 10ns						nCK	
SRX to commands not requiring a locked DLL in Self Refresh ABORT	tXS_ABORT(min)	Min=tRFC4(min) + 10ns						nCK	
Exit Self Refresh to ZQCL,ZQCS and MRS (CL,CWL,WR,RTP and Gear Down)	tXS_FAST(min)	Min=tRFC4(min) + 10ns						nCK	
Exit Self Refresh to commands re- quiring a locked DLL	tXSDLL	tDLLK(min)	-	tDLLK(min)	-	tDLLK(min)	-	nCK	
Minimum CKE low width for Self re- fresh entry to exit timing	tCKESR	tCKE(min) + 1nCK	-	tCKE(min) + 1nCK	-	tCKE(min) + 1nCK	-	nCK	
Minimum CKE low width for Self re- fresh entry to exit timing with CA Par- ity enabled	tCKESR_PAR	tCKE(min) + 1nCK + PL	-	tCKE(min) + 1nCK + PL	-	tCKE(min) + 1nCK + PL	-	nCK	
Valid Clock Requirement after Self Refresh Entry (SRE) or Power-Down Entry (PDE)	tCKSRE	Max (5nCK,10 ns)	-	Max (5nCK,10 ns)	-	Max (5nCK,10 ns)	-	nCK	
Valid Clock Requirement after Self Refresh Entry (SRE) or Power-Down when CA Parity is enabled	tCKSRE_PAR	Max (5nCK, 10ns) + PL	-	Max (5nCK, 10ns) + PL	-	Max (5nCK, 10ns) + PL	-	nCK	

Speed		DDR4-2666		DDR4-2933		DDR4-3200		Unit	Note	
Parameter	Symbol	Min	Max	Min	Max	Min	Max			
Valid Clock Requirement before Self Refresh Exit (SRX) or Power-Down Exit (PDX) or Reset Exit	tCKSRX	Max (5nCK, 10ns)	-	Max (5nCK,10ns)	-	Max (5nCK,10ns)	-	nCK		
Power Down Timing										
Exit Power Down with DLL on to any valid command;Exit Precharge Power Down with DLL frozen to commands not requiring a locked DLL	tXP	Max (4nCK, 6ns)	-	Max (4nCK, 6ns)	-	Max (4nCK, 6ns)	-	nCK		
CKE minimum pulse width	tCKE	Max (3nCK, 5ns)	-	Max (3nCK, 5ns)	-	Max (3nCK, 5ns)	-		31 32	
Command pass disable delay	tCPDED	4	-	4	-	4	-	nCK		
Power Down Entry to Exit Timing	tPD	tCKE(min)	9*tREFI	tCKE(min)	9*tREFI	tCKE(min)	9*tREFI		6	
Timing of ACT command to Power Down entry	tACTPDEN	2	-	2	-	2	-	nCK	7	
Timing of PRE or PREA command to Power Down entry	tPRPDEN	2	-	2	-	2	-	nCK	7	
Timing of RD/RDA command to Power Down entry	tRDPDEN	Min=RL + 4 + 1							nCK	
Timing of WR command to Power Down entry (BL8OTF, BL8MRS, BC4OTF)	tWRPDEN	Min=WL + 4 + (tWR/tCK(avg))							nCK	4
Timing of WRA command to Power Down entry(BL8OTF, BL8MRS, BC4OTF)	tWRAPDEN	Min=WL + 4 + WR + 1							nCK	5
Timing of WR command to Power Down entry (BC4MRS)	tWRPBC4DEN	Min=WL + 2 + (tWR/tCK(avg))							nCK	4
Timing of WRA command to Power Down entry (BC4MRS)	tWRAPBC4DEN	Min=WL + 2 + WR + 1							nCK	5
Timing of REF command to Power Down entry	tREFPDEN	2	-	2	-	2	-	nCK	7	
Timing of MRS command to Power Down entry	tMRSPDEN	tMOD(min)	-	tMOD (min)	-	tMOD (min)	-			

Speed		DDR4-2666		DDR4-2933		DDR4-3200		Unit	Note
Parameter	Symbol	Min	Max	Min	Max	Min	Max		
Mode Register Set command cycle time in PDA mode	tMRD_PDA	Max (16nCK, 10ns)	-	Max (16nCK, 10ns)	-	Max (16nCK, 10ns)	-	nCK	
Mode Register Set command update delay in PDA mode	tMOD_PDA	tMOD		tMOD		tMOD		nCK	
Asynchronous RTT turn-on delay (Power-Down with DLL frozen)	tAONAS	1	9	1	9	1	9	ns	
Asynchronous RTT turn-off delay (Power-Down with DLL frozen)	tAOFAS	1	9	1	9	1	9	ns	
RTT dynamic change skew	tADC	0.28	0.72	0.26	0.74	0.26	0.74	tCK(avg)	
First DQS_t/DQS_n rising edge after write leveling mode is programmed	tWLMRD	40	-	40	-	40	-	nCK	12
DQS_t/DQS_n delay after write leveling mode is programmed	tWLDQSEN	25	-	25	-	25	-	nCK	12
Write leveling setup time from rising CK_t, CK_c crossing to rising DQS_t/ DQS_n crossing	tWLS	0.13	-	0.13	-	0.13	-	tCK(avg)	
Write leveling hold time from rising DQS_t/DQS_n crossing to rising CK_t, CK_c crossing	tWLH	0.13	-	0.13	-	0.13	-	tCK(avg)	
Write leveling output delay	tWLO	0	0.95	0	0.95	0	0.95	ns	
Write leveling output error	tWLOE	-	2	-	2	-	2	ns	
CA Parity Timing									
Commands not guaranteed to be executed during this time	tPAR_UNKNOWN	-	PL	-	PL	-	PL	nCK	
Delay from errant command to ALERT_n assertion	tPAR_ALERT_ON	-	PL + 6ns	-	PL + 6ns	-	PL + 6ns	nCK	
Pulse width of ALERT_n signal when asserted	tPAR_ALERT_PW	80	160	88	176	96	192	nCK	

Speed		DDR4-2666		DDR4-2933		DDR4-3200		Unit	Note
Parameter	Symbol	Min	Max	Min	Max	Min	Max		
Time from when Alert is asserted till controller must start providing DES commands in Persistent CA parity mode	tPAR_ALERT_RSP	-	71	-	78	-	85	nCK	
Parity Latency	PL	5		6		6		nCK	
CRC error to ALERT_n latency	tCRC_ALERT	3	13	3	13	3	13	ns	
CRC ALERT_n pulse width	CRC_ALERT_PW	6	10	6	10	6	10	nCK	
Gear Down Timing									
Exit RESET from CKE HIGH to a valid MRS geardown (T2/Reset)	tXPR_GEAR	tXPR	-	tXPR	-	tXPR	-		
CKE High Assert to Gear Down Enable time(T2/CKE)	tXS_GEAR	tXS	-	tXS	-	tXS	-		
MRS command to Sync pulse time(T3)	tSYNC_GEAR	tMOD + 4nCK	-	tMOD + 4nCK	-	tMOD + 4nCK	-		27
Sync pulse to First valid command(T4)	tCMD_GEAR	tMOD	-	tMOD	-	tMOD	-		27
Geardown setup time	tGEAR_setup	2	-			2	-	nCK	
Geardown hold time	tGEAR_hold	2	-			2	-	nCK	
tREFI									
tRFC1 (min)	8Gb	350	-	350	-	350	-	ns	34
tRFC2 (min)	8Gb	260	-	260	-	260	-	ns	34
tRFC4 (min)	8Gb	160	-	160	-	160	-	ns	34

Note:

- 1 Start of internal Write transaction is defined as follows :
 - For BL8 (Fixed by MRS and on-the-fly) : Rising clock edge 4 clock cycles after WL.
 - For BC4 (on-the-fly) : Rising clock edge 4 clock cycles after WL.
 - For BC4 (fixed by MRS) : Rising clock edge 2 clock cycles after WL.
- 2 A separate timing parameter will cover the delay from Write to Read when CRC and DM are simultaneously enabled.
- 3 Commands requiring a locked DLL are Read (and Read Auto Precharge) and synchronous ODT commands.
- 4 tWR is defined in ns, for calculation of tWRPDEN it is necessary to round up tWR/tCK following rounding algorithm defined in Section 9.5
- 5 WR in clock cycles as programmed in MR0.
- 6 tREFI depends on T_{OPER}.
- 7 CKE is allowed to be registered low while operations such as row activation, precharge, autoprecharge or refresh are in progress, but power-down IDD spec will not be applied until finishing those operations.
- 8 For these parameters, the DDR4 SDRAM device supports tnPARAM[nCK]=RU{tPARAM[ns]/tCK(avg)[ns]}, which is in clock cycles assuming all input clock jitter specifications are satisfied.
- 9 When CRC and DM are both enabled, tWR_CRC_DM is used in place of tWR.
- 10 When CRC and DM are both enabled, tWTR_S_CRC_DM is used in place of tWTR_S.
- 11 When CRC and DM are both enabled, tWTR_L_CRC_DM is used in place of tWTR_L.
- 12 The max values are system dependent.
- 13 DQ to DQS total timing per group where the total includes the sum of deterministic and random timing terms for a specified BER. BER spec and measurement

method are TBD.

- 14 The deterministic component of the total timing. Measurement method TBD.
- 15 DQ to DQ static offset relative to strobe per group. Measurement method TBD.
- 16 This parameter will be characterized and guaranteed by design.
- 17 When the device is operated with the input clock jitter, this parameter needs to be derated by the actual $t_{jit(per)}_{total}$ of the input clock. (output deratings are relative to the SDRAM input clock). Example TBD.
- 18 DRAM DBI mode is off.
- 19 DRAM DBI mode is enabled. Applicable to x8 and x16 DRAM only.
- 20 tQSL describes the instantaneous differential output low pulse width on DQS_t - DQS_c, as measured from on falling edge to the next consecutive rising edge
- 21 tQSH describes the instantaneous differential output high pulse width on DQS_t - DQS_c, as measured from on falling edge to the next consecutive rising edge
- 22 There is no maximum cycle time limit besides the need to satisfy the refresh interval tREFI
- 23 tCH(abs) is the absolute instantaneous clock high pulse width, as measured from one rising edge to the following falling edge
- 24 tCL(abs) is the absolute instantaneous clock low pulse width, as measured from one falling edge to the following rising edge
- 25 Total jitter includes the sum of deterministic and random jitter terms for a specified BER. BER target and measurement method are TBD.
- 26 The deterministic jitter component out of the total jitter. This parameter is characterized and guaranteed by design.
- 27 This parameter has to be even number of clocks
- 28 When CRC and DM are both enabled, tWR_CRC_DM is used in place of tWR.
- 29 When CRC and DM are both enabled tWTR_S_CRC_DM is used in place of tWTR_S.

- 30 When CRC and DM are both enabled tWTR_L_CRC_DM is used in place of tWTR_L.
- 31 After CKE is registered Low, CKE signal level shall be maintained below VILDC for tCKE specification (Low pulse width).
- 32 After CKE is registered High, CKE signal level shall be maintained above VIHDC for tCKE specification (High pulse width).
- 33 Defined between end of MPR Read burst and MRS which reloads MPR or disables MPR function.
- 34 Parameters apply from tCK(avg)min to tCK(avg)max at all standard JEDEC clock period values as stated in the “Speed Bin”.
- 35 This parameter must keep consistency with “Speed Bin”.
- 36 DDR4-1600 AC timing apply if DRAM operates at lower than 1600 MT/s data rate. $UI=tCK(avg).min/2$
- 37 Applied when DRAM is in DLL ON mode.
- 38 Assume no jitter on input clock signals to the DRAM
- 39 Value is only valid for RONNOM = 34Ω
- 40 1tCK toggle mode with setting MR4:A11 to 0
- 41 2tCK toggle mode with setting MR4:A11 to 1, which is valid for DDR4-2400/2666/3200 speed grade.
- 42 1tCK mode with setting MR4:A12 to 0
- 43 2tCK mode with setting MR4:A12 to 1, which is valid for DDR4-2400/2666/3200 speed grade.
- 44 The maximum read preamble is bounded by tLZ(DQS)min on the left side and tDQSCK(max) on the right side. See “Clock to Data Strobe Relationship” of DDR4 Operation Guide. Boundary of DQS Low-Z occur one cycle earlier in 2tCK toggle mode which is illustrated in “Read Preamble”.
- 45 DQ falling signal middle-point of transferring from High to Low to first rising edge of DQS diff-signal cross-point.
- 46 Last falling edge of DQS diff-signal cross-point to DQ rising signal middle-point of transferring from Low to High

- 47 VrefDQ value must be set to either its midpoint or Vcent_DQ(midpoint) in order to capture DQ0 or DQL0 low level for entering PDA mode.
- 48 The maximum read postamble is bound by tDQSCK(min) plus tQSH(min) on the left side and tHZ(DQS)max on the right side. See “Clock to Data Strobe Relationship” of DDR4 Operation Guide.
- 49 Reference level of DQ output signal is specified with a midpoint as a widest part of Output signal eye which should be approximately $0.7 * VDDQ$ as a center level of the static single-ended output peak-to-peak swing with a driver impedance of 34 ohms and an effective test load of 50 ohms to $V_{TT} = VDDQ$
- 50 For MR7 commands, the minimum delay to a subsequent non-MRS command is 5nCK.

9.5 Rounding Algorithms

Software algorithms for calculation of timing parameters are subject to rounding errors from many sources. For example, a system may use a memory clock with a nominal frequency of 933.33... MHz, or a clock period of 1.0714... ns. Similarly, a system with a memory clock frequency of 1066.66... MHz yields mathematically a clock period of 0.9375... ns. In most cases, it is impossible to express all digits after the decimal point exactly, and rounding must be done because the DDR4 SDRAM specification establishes a minimum granularity for timing parameters of 1 ps.

Rules for rounding must be defined to allow optimization of device performance without violating device parameters. These algorithms rely on results that are within correction factors on device testing and specification to avoid losing performance due to rounding errors.

These rules are:

- Clock periods such as tCKAVGmin are defined to 1 ps of accuracy; for example, 0.9375... ns is defined as 937 ps and 1.0714... ns is defined as 1071 ps.
- Using real math, parameters like tAmin, tRCDmin, etc. which are programmed in systems in numbers of clocks (nCK) but expressed in units of time (in ns) are divided by the clock period (in ns) yielding a unitless ratio, a correction factor of 2.5% is subtracted, then the result is set to the next higher integer number of clocks: $nCK = \text{ceiling} [(\text{parameter_in_ns} / \text{application_tCK_in_ns}) - 0.025]$
- Alternatively, programmers may prefer to use integer math instead of real math by expressing timing in ps, scaling the desired parameter value by 1000, dividing by the application clock period, adding an inverse correction factor of 97.4%, dividing the result by 1000, then truncating down to the next lower integer value: $nCK = \text{truncate} [\{ (\text{parameter_in_ps} \times 1000) / (\text{application_tCK_in_ps}) + 974 \} / 1000]$
- Either algorithm yields identical results. In case of conflict between results, the preferred algorithm is the integer math algorithm.
- This algorithm applies to all timing parameters documented in a Serial Presence Detect (SPD) when converting from ns to nCK. Other timing parameters may use a simpler algorithm: $nCK = \text{ceiling} (\text{parameter_in_ns} \div \text{application_tCK_in_ns})$.

9.6 The DQ Input Receiver Compliance Mask for Voltage and Timing

The DQ input receiver compliance mask for voltage and timing is shown in Figure 9-2 below. The receiver mask (Rx Mask) defines area the input signal must not encroach in order for the DRAM input receiver to be able to successfully capture a valid input signal with BER of $1e-16$; Any input signal encroaching within the Rx Mask is subject to being invalid data. The Rx Mask is the receiver property for each DQ input pin and it is not the valid data-eye.

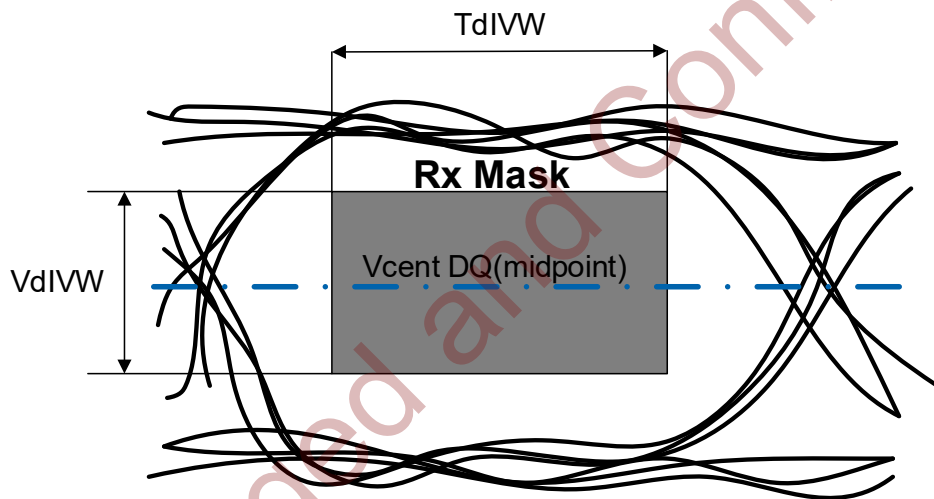

Figure 9-2 DQ Receiver(Rx) Compliance Mask

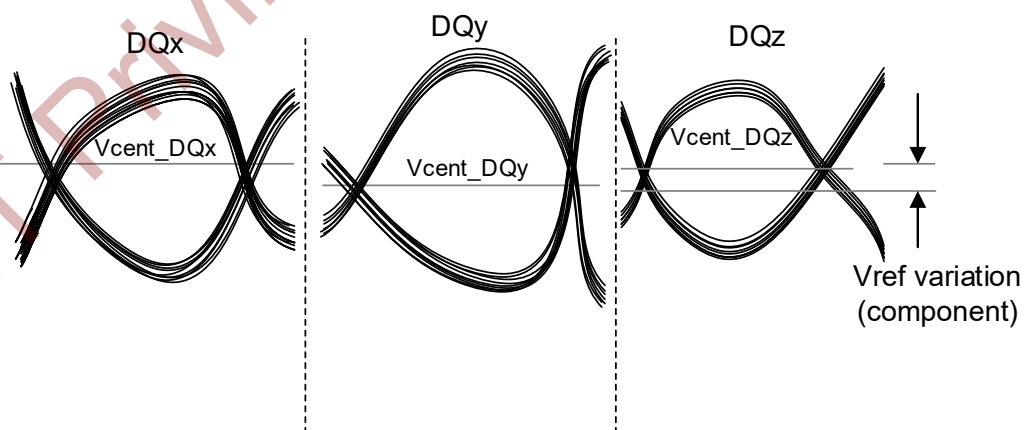

Figure 9-3 Across Pin Vref DQ Voltage Variation

The Vref_DQ voltage is an internal reference voltage level that shall be set to the properly trained setting, which is generally Vcent_DQ(midpoint), in order to have valid Rx Mask values.

Vcent_DQ(pin avg) is defined as the midpoint between the largest Vref_DQ voltage level and the smallest Vref_DQ voltage level across all DQ pins for a given DRAM component. Each DQ pin Vref level is defined by the center, i.e. widest opening, of the cumulative data input eye as depicted in Figure 9-3. This clarifies that any DRAM component level variation must be accounted for within the DRAM Rx mask. The component level Vref will be set by the system to account for RON and ODT settings.

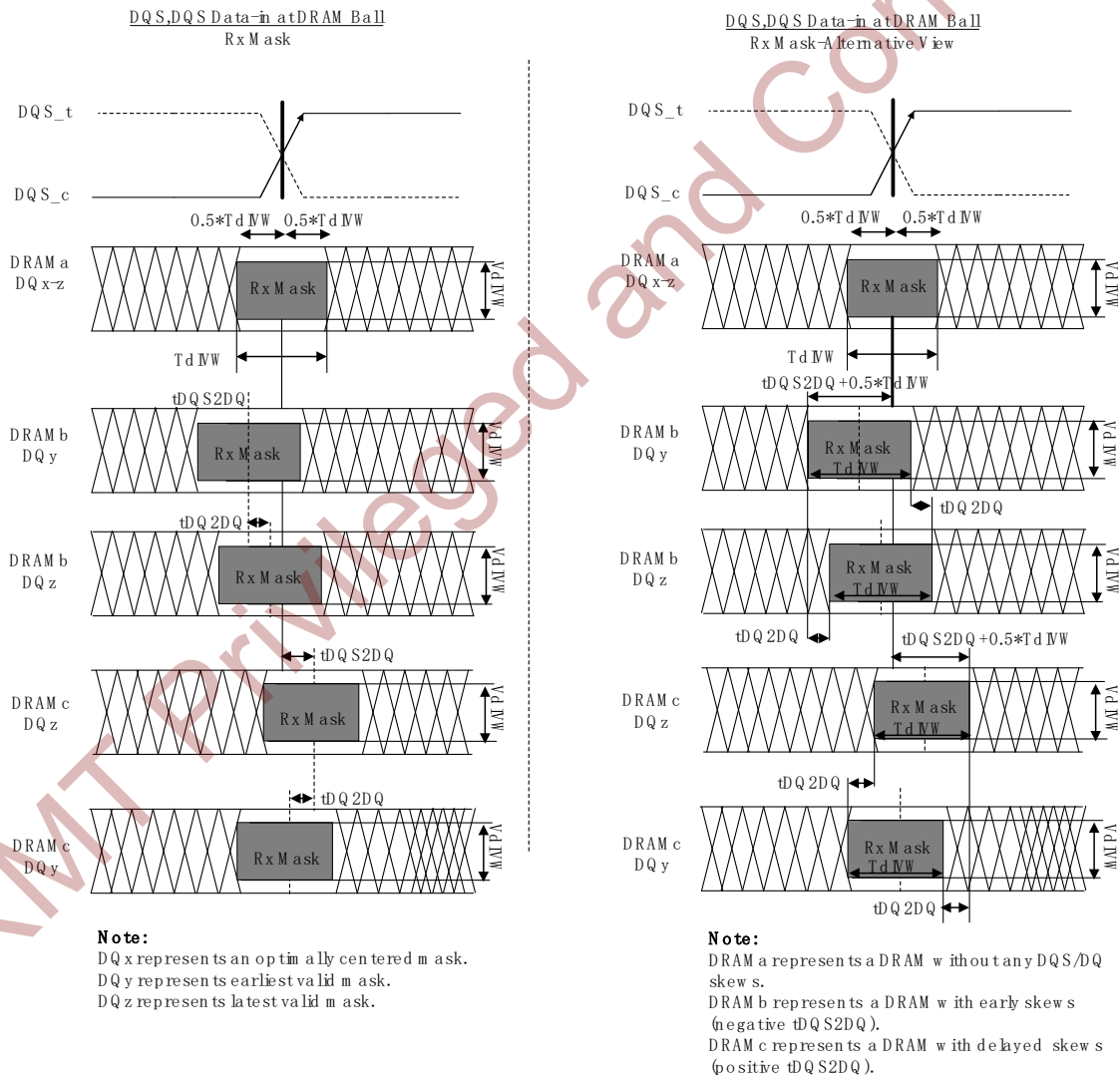

Figure 9-4 DQS to DQ and DQ to DQ Timings at DRAM Balls

Note:

- 1 Figures show skew allowed between DRAM to DRAM and DQ to DQ for a DRAM. Signals assume data centered aligned at DRAM Latch.
- 2 TdiPW is not shown; composite data-eyes shown would violate TdiPW.
- 3 VCENT DQ(midpoint) is not shown but is assumed to be midpoint of VdiVW.

CXMT Privileged and Confidential

All of the timing terms in Figure 9-4 are measured at the VdIVW voltage levels centered around Vcent_DQ(midpoint) and are referenced to the DQS_t/DQS_c center aligned to the DQ per pin.

The rising edge slew rates are defined by srr1 and srr2. The slew rate measurement points for a rising edge are shown in Figure 9-5 below: A low to high transition tr1 is measured from .5*VdiVW(max) below Vcent_DQ(midpoint) to the last transition through 0.5*VdiVW(max) above Vcent_DQ(midpoint) while tr2 is measured from the last transition through 0.5*VdiVW(max) above Vcent_DQ(midpoint) to the first transition through the 0.5*VIHL_AC(min) above Vcent_DQ(midpoint).

Rising edge slew rate equations:

- $srr1 = VdIVW(max) / tr1$
- $srr2 = (VIHL_AC(min) - VdIVW(max)) / (2*tr2)$

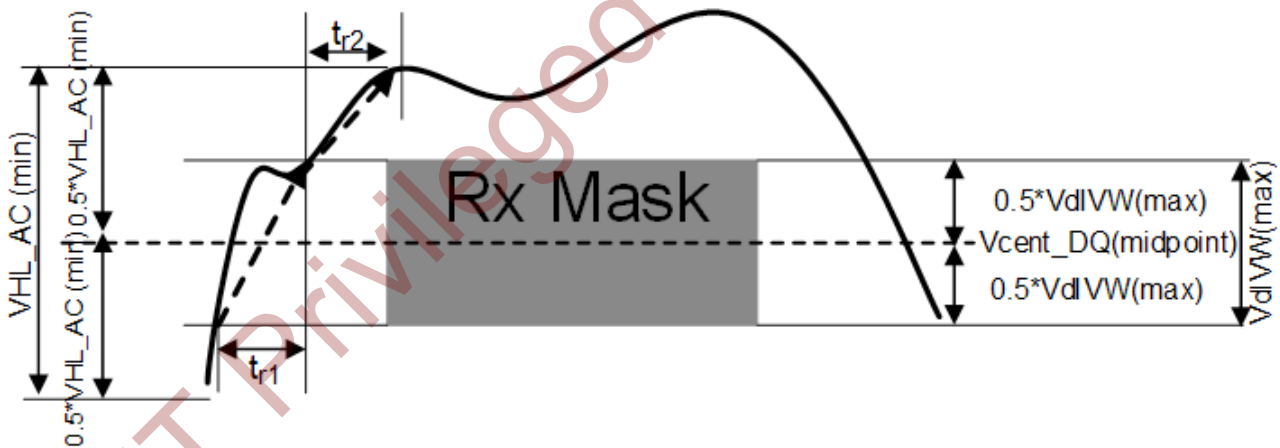

Figure 9-5 Slew Rate Conditions for Rising Transition

The falling edge slew rates are defined by srf1 and srf2. The slew rate measurement points for a falling edge are shown in Figure 9-6 below: A high to low transition tf1 is measured from 0.5*VdiVW(max) above Vcent_DQ(midpoint) to the last transition through 0.5*VdiVW(max) below Vcent_DQ(midpoint) while tf2 is measured from the last transition through 0.5*VdiVW(max) below Vcent_DQ(midpoint) to the first transition through the 0.5*VIHL_AC(min) below Vcent_DQ(pin mid).

Falling edge slew rate equations:

- $srf1 = VdiVW(max) / tf1$
- $srf2 = (VIHL_AC(min) - VdiVW(max)) / (2 * tf2)$

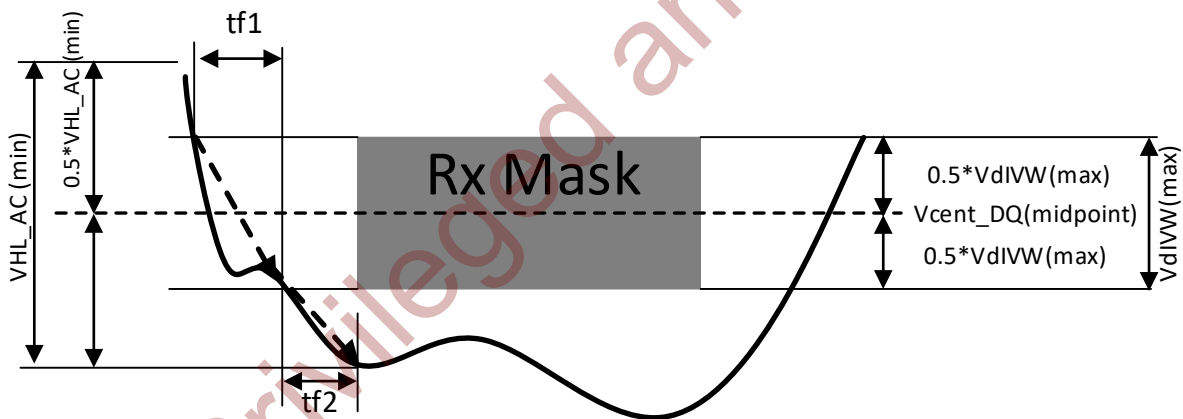

Figure 9-6 Slew Rate Conditions for Falling Transition

Table 9-4 DRAM DQs In Receive Mode; * UI=tck(avg)min/2

Symbol	Parameter	1600,1866,2133		2400		2666		Unit	Note
		Min	Max	Min	Max	Min	Max		
VdIVW	Rx Mask voltage - pK-pK	-	136	-	130	-	120	mV	1,2,10
TdIVW	Rx timing window	-	0.2	-	0.2	-	0.22	UI*	1,2,10
VIHL_AC	DQ AC input swing pk-pk	186	-	160	-	150	-	mV	3,4,10
TdIPW	DQ input pulse width	0.58	-	0.58	-	0.58	-	UI*	5,10
tDQS2DQ	Rx Mask DQS to DQ offset	-0.17	0.17	-0.17	0.17	-0.19	0.19	UI*	6,10
tDQ2DQ	Rx Mask DQ to DQ offset	-	TBD	-	TBD	-	0.105	UI*	7
srr1	Input Slew Rate over VdIVW if tCK >= 0.937ns	1.0	9	1.0	9	1	9	V/ns	8,10
srf1	Input Slew Rate over VdIVW if 0.937ns > tCK >= 0.625ns	-	-	1.25	9	1.25	9	V/ns	8,10
srr2	Rising Input Slew Rate over 1/2 VIHL_AC	0.2*srr1	9	0.2*srr1	9	0.2*srr1	9	V/ns	9,10
srf2	Falling Input Slew Rate over 1/2 VIHL_AC	0.2*srf1	9	0.2*srr1	9	0.2*srr1	9	V/ns	9,10

Note:

- 1 Data Rx mask voltage and timing total input valid window where VdIVW is centered around Vcent_DQ (midpoint) after VrefDQ training is completed. The data Rx mask is applied per bit and should include voltage and temperature drift terms. The input buffer design specification is to achieve at least a BER = e-16 when the RxMask is not violated. The BER will be characterized and extrapolated if necessary using a dual dirac method from a higher BER(tbd).
- 2 Defined over the DQ internal Vref range 1.
- 3 Overshoot and Undershoot Specifications see “AC Overshoot Specification for Data, Strobe and Mask”
- 4 DQ input pulse signal swing into the receiver must meet or exceed VIH AC(min). VIH AC(min) is to be achieved on an UI basis when a rising and falling edge occur in the same UI, i.e. a valid TdiPW.
- 5 DQ minimum input pulse width defined at the Vcent_DQ(midpoint).
- 6 DQS to DQ offset is skew between DQS and DQs within a nibble (x4) or word (x8, x16) at the DDR4 SDRAM balls over process, voltage, and temperature.
- 7 DQ to DQ offset is skew between DQs within a nibble (x4) or word (x8, x16) at the DDR4 SDRAM balls for a given component over process, voltage, and temperature.
- 8 Input slew rate over VdIVW Mask centered at Vcent_DQ(midpoint). Slowest DQ slew rate to fastest DQ slew rate per transition edge must be within 1.7 V/ns of each other.
- 9 Input slew rate between VdIVW Mask edge and VIH AC(min) points.
- 10 All Rx Mask specifications must be satisfied for each UI. For example, if the minimum input pulse width is violated when satisfying TdiVW(min), VdiVW(max), and minimum slew rate limits, then either TdiVW(min) or minimum slew rates would have to be increased to the point where the minimum input pulse width would no longer be violated.

9.7 Command, Control, and Address Setup, Hold, and Derating

The total tIS (setup time) and tIH (hold time) required is calculated to account for slew rate variation by adding the data sheet tIS (base) values, the VIL(AC)/VIH(AC) points, and tIH (base) values, the VIL(DC)/VIH(DC) points; to the ΔtIS and ΔtIH derating values, respectively. The base values are derived with single-end signals at 1V/ns and differential clock at 2V/ns. Example: tIS (total setup time) = tIS (base) + ΔtIS . For a valid transition, the input signal has to remain above/below VIH(AC)/VIL(AC) for the time defined by tVAC.

Although the total setup time for slow slew rates might be negative (for example, a valid input signal will not have reached VIH(AC)/VIL(AC) at the time of the rising clock transition), a valid

input signal is still required to complete the transition and to reach $V_{IH}(AC)/V_{IL}(AC)$. For slew rates that fall between the values listed in derating tables, the derating values may be obtained by linear interpolation.

Setup (t_{IS}) nominal slew rate for a rising signal is defined as the slew rate between the last crossing of $V_{IL}(DC)_{max}$ and the first crossing of $V_{IH}(AC)_{min}$ that does not ring back below $V_{IH}(DC)_{min}$. Setup (t_{IS}) nominal slew rate for a falling signal is defined as the slew rate between the last crossing of $V_{IH}(DC)_{min}$ and the first crossing of $V_{IL}(AC)_{max}$ that does not ring back above $V_{IL}(DC)_{max}$. Hold (t_{IH}) nominal slew rate for a rising signal is defined as the slew rate between the last crossing of $V_{IL}(DC)_{max}$ and the first crossing of $V_{IH}(AC)_{min}$ that does not ring back below $V_{IH}(DC)_{min}$.

Hold (t_{IH}) nominal slew rate for a rising signal is defined as the slew rate between the last crossing of $V_{IH}(DC)_{min}$ and the first crossing of $V_{IL}(AC)_{min}$ that does not ring back above $V_{IL}(DC)_{max}$.

Table 9-5 Command, Address, Control Setup and Hold Values

DDR4-	1600	1866	2133	2400	2666	2933	3200	Unit	Reference
$t_{IS}(\text{base, AC}100)$	115	100	80	62	-	-	-	ps	$V_{IH}/L(\text{ac})$
$t_{IH}(\text{base, DC}75)$	140	125	105	87	-	-	-	ps	$V_{IH}/L(\text{dc})$
$t_{IS}(\text{base, AC } 90)$	-	-	-	-	55	TBD	TBD	ps	$V_{IH}/L(\text{ac})$
$t_{IH}(\text{base, DC } 65)$	-	-	-	-	80	TBD	TBD	ps	$V_{IH}/L(\text{dc})$
$t_{IS}/t_{IH}@ V_{REF}$	215	200	180	162	145	TBD	TBD	ps	

Note:

- 1 Base ac/dc referenced for 1V/ns slew rate and 2 V/ns clock slew rate.
- 2 Values listed are referenced only; applicable limits are defined elsewhere.

Table 9-6 Command, Address, Control Input Voltage Values

DDR4-	1600	1866	2133	2400	2666	2933	3200	Unit	Reference
VIH. CA(AC)min	100	100	100	100	90	TBD	TBD	mV	VIH/L(ac)
VIH. CA(DC)min	75	75	75	75	65	TBD	TBD	mV	VIH/L(dc)
VIL. CA(DC)max	-75	-75	-75	-75	-65	TBD	TBD	mV	VIH/L(ac)
VIL. CA(AC)max	-100	-100	-100	-100	-90	TBD	TBD	mV	VIH/L(dc)

Note:

- 1 Command, Address, Control input levels relative to VREFCA.
- 2 Values listed are referenced only; applicable limits are defined elsewhere.

Table 9-7 Derating Values DDR4-1600/1866/2133/2400 tIS/tIH-ac/dc Based

		$\Delta tIS, \Delta tIH$ derating in [ps] AC/DC Based ¹															
		CK _t , CK _c Differential Slew Rate															
		10.0 V/ns		8.0 V/ns		6.0 V/ns		4.0 V/ns		3.0 V/ns		2.0 V/ns		1.5 V/ns		1.0 V/ns	
		ΔtIS	ΔtIH	ΔtIS	ΔtIH	ΔtIS	ΔtIH	ΔtIS	ΔtIH	ΔtIS	ΔtIH	ΔtIS	ΔtIH	ΔtIS	ΔtIH	ΔtIS	ΔtIH
ADDR,CNTL Input Slew Rate V/ns	7	76	54	76	55	77	56	79	58	82	60	86	64	94	73	111	89
	6	73	53	74	53	75	54	77	56	79	58	83	63	92	71	108	88
	5	70	50	71	51	72	52	74	54	76	56	80	60	88	68	105	85
	4	65	46	66	47	67	48	69	50	71	52	75	56	83	65	100	81
	3	57	40	57	41	58	42	60	44	63	46	67	50	75	58	92	75
	2	40	28	41	28	42	29	44	31	46	33	50	38	58	46	75	63
	1.5	23	15	24	16	25	17	27	19	29	21	33	25	42	33	58	50
	1	-10	-10	-9	-9	-8	-8	-6	-6	-4	-4	0	0	8	8	25	25
	0.9	-17	-14	-16	-14	-15	-13	-13	-10	-11	-8	-7	-4	1	4	18	21
	0.8	-26	-19	-25	-19	-24	-18	-22	-16	-20	-14	-16	-9	-7	-1	9	16
	0.7	-37	-26	-36	-25	-35	-24	-33	-22	-31	-20	-27	-16	-18	-8	-2	9
	0.6	-52	-35	-51	-34	-50	-33	-48	-31	-46	-29	-42	-25	-33	-17	-17	0
	0.5	-73	-48	-72	-47	-71	-46	-69	-44	-67	-42	-63	-38	-54	-29	-38	-13
0.4	-104	-66	-103	-66	-102	-65	-100	-63	-98	-60	-94	-56	-85	-48	-69	-31	

Note:

1. VIH/L(ac) = ± 100mV, VIH/L(dc) = ± 75mV; relative to VREFCA.

Table 9-8 Derating Values DDR4-2666 tIS/tIH-ac/dc Based

		$\Delta tIS, \Delta tIH$ derating in [ps] AC/DC based ¹															
		CK_t, CK_c Differential Slew Rate															
		10.0 V/ns		8.0 V/ns		6.0 V/ns		4.0 V/ns		3.0 V/ns		2.0 V/ns		1.5 V/ns		1.0 V/ns	
		ΔtIS	ΔtIH	ΔtIS	ΔtIH	ΔtIS	ΔtIH	ΔtIS	ΔtIH	ΔtIS	ΔtIH	ΔtIS	ΔtIH	ΔtIS	ΔtIH	ΔtIS	ΔtIH
ADDR,CNTL Input Slew Rate V/ns	7	68	47	69	47	70	48	72	50	73	52	77	56	85	63	100	78
	6	66	45	67	46	68	47	69	49	71	50	75	54	83	62	98	77
	5	63	43	64	44	65	45	66	46	68	48	72	52	80	60	95	75
	4	59	40	59	40	60	41	62	43	64	45	68	49	75	56	90	71
	3	51	34	52	35	53	36	54	38	56	40	60	43	68	51	83	66
	2	36	24	37	24	38	25	39	27	41	29	45	33	53	40	68	55
	1.5	21	13	22	13	23	14	24	16	26	18	30	22	38	29	53	44
	1	-9	-9	-8	-8	-8	-8	-6	-6	-4	-4	0	0	8	8	23	23
	0.9	-15	-13	-15	-12	-14	-11	-12	-9	-10	-7	-6	-4	1	4	16	19
	0.8	-23	-17	-23	-17	-22	-16	-20	-14	-18	-12	-14	-8	-7	-1	8	14
	0.7	-34	-23	-33	-22	-32	-21	-30	-20	-28	-18	-25	-14	-17	-6	-2	9
	0.6	-47	-31	-47	-30	-46	-29	-44	-27	-42	-25	-38	-22	-31	-14	-16	1
	0.5	-67	-42	-66	-41	-65	-40	-63	-38	-61	-36	-58	-33	-50	-25	-35	-10
0.4	-95	-58	-95	-57	-94	-56	-92	-54	-90	-53	-86	-49	-79	-41	-64	-26	

Note:

 1. VIH/L(ac) = \pm tbd mV, VIH/L(dc) = \pm tbd mV; relative to VREFCA.